

Interfacing Analog Audio Bandwidth Signals to the HPC

National Semiconductor
 Application Note 484
 Ashok Krishnamurthy
 April 1987



INTRODUCTION

This report describes a method of interfacing analog audio bandwidth signals to the National Semiconductor HPC microcontroller. The analog signal is converted to a digital value using the National Semiconductor TP3054 codec/filter combo. The digital value is then transferred to the HPC using the MICROWIRE/PLUSTM synchronous serial interface. The digital output sample computed by the HPC is also transferred to the TP3054 using the MICROWIRE/PLUS interface. The TP3054 then converts this digital value to an analog signal.

ADVANTAGES OF USING A CODEC

There are a number of advantages in using a codec for A/D and D/A conversion of analog signals.

1. The codec/filter combos such as the TP3054 integrate a number of functions on a single chip. Thus the TP3054 includes the analog anti-aliasing filters, the Sample-and-Hold circuitry and the A/D and D/A converters for analog signal interfacing.
2. The μ -law coding effectively codes a 14-bit conversion accuracy in 8 bits. This allows the interface to the HPC to be greatly simplified.

DISADVANTAGES IN USING A CODEC

While the use of a codec is appropriate for audio (in particular speech) processing applications, it has a number of disadvantages in other cases.

1. The sampling rate is fixed at 8 kHz. If lower or higher sampling rates are desired, the codec cannot be used. Note that the real-time signal processing that the HPC can perform at a 8 kHz sampling rate is limited.
2. The resolution is fixed, and is about 14 bits/sample.
3. Digital filtering algorithms require that the samples used in the processing be linear coded PCM. Thus the 8-bit μ -law PCM values output by the codec need to be converted to linear coded PCM. Correspondingly, the output of the digital filter, which is in linear coded PCM needs to be converted to 8-bit μ -law PCM before outputting to the codec. This requires additional processing per sample.

DESCRIPTION OF THE INTERFACE

The circuit schematic of the interface is shown in Figure 1. Note that the schematic does not show complete details of the HPC. Only the HPC pins that are relevant to this interface are shown. A wire-wrapped version of the circuit has been constructed on a NSC HPC 16040 Chip Carrier Board.

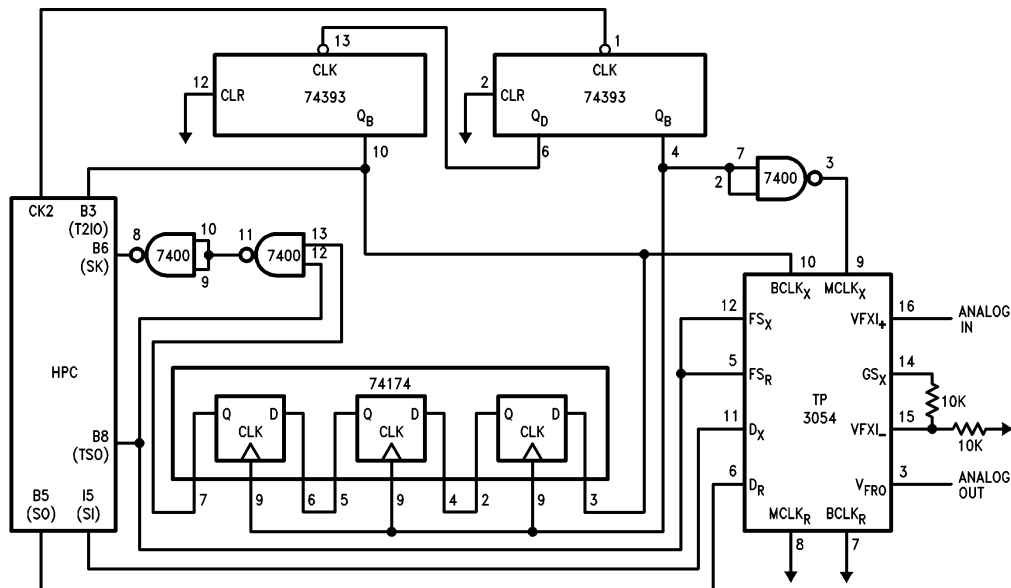

TL/DD/9246-1

FIGURE 1. Circuit Schematic

HPCTM and MICROWIRE/PLUSTM are trademarks of National Semiconductor Corporation.

Note that this report does not go into the details about the use of the TP3054 codec chip or programming the HPC. It also does not discuss the μ -law to linear and linear to μ -law code conversion in detail. For more information on these issues, please consult the references listed at the end.

1. **Codec Signalling Considerations.** The TP3054 can operate in either synchronous or asynchronous modes. Further, in each of these modes, it uses short or long frame sync operation. The circuit shown in *Figure 1* runs the codec in synchronous mode with long-frame-sync operation.

The codec requires 4 clock sources for proper operation in the synchronous mode. These are MCLK-x, BCLK-x, FS-x and FS-r. MCLK-x is a master clock and is used to clock the switched-capacitor filters. BCLK-x is the bit shift clock, and FS-x and FS-r are the frame sync clocks. These clocks need to be synchronous.

These clocks are obtained in the circuit as follows. MCLK-x is obtained by dividing the HPC CK2 clock output by 4. If the HPC is using a 16 MHz crystal, this results in MCLK-x being 2 MHz.

BCLK-x is obtained by dividing CK2 by 64. This gives an effective value for BCLK-x of 125 kHz. Note that MCLK-x is inverted before being fed to the codec. This is done to synchronize MCLK-x and BCLK-x on their leading edges.

FS-x and FS-r are the same clocks in the circuit. They are obtained by dividing BCLK-x by 16 using the timer T2 on the HPC. BCLK-x is used as the external clock input on pin T2IO of the HPC and FS-x (FS-r) is obtained from the timer synchronous output TS0. Note that the delay inherent in the HPC between the underflow of a timer and the toggling of the corresponding output allows FS-x and BCLK-x to be leading edge synchronized (more accurately, the delay is within the codec's acceptable limits.) Note that in order to accomplish these functions, the HPC pins need to be properly configured. This is not described here. Please refer to the appropriate HPC documentation and consult the sample program included with this report.

2. **MICROWIRE/PLUS Interface Considerations.** MICROWIRE/PLUS is a National Semiconductor defined 8-bit serial synchronous communication interface. It is designed to allow easy interfacing of NSC microcontrollers and peripheral chips. The HPC microcontroller has a MICROWIRE/PLUS interface; however the TP3054 codec does not. Thus some external "glue logic" is necessary to allow the HPC and the TP3054 to be interfaced.

The HPC MICROWIRE/PLUS interface is operated in Slave mode for this application. This means that the shift clock needed to latch-in/shift-out data from the Micro-wire SIO register is provided externally on the SK pin. Micro-wire latches in data on the leading edge of the SK clock and shifts out data on the trailing edge of SK. Also SK needs to be a burst clock for proper operation.

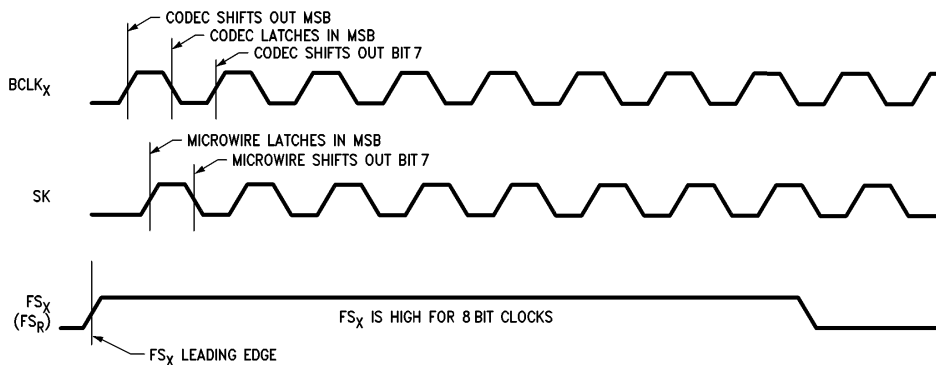

FIGURE 2. Timing Waveforms

TL/DD/9246-2

The codec shifts out data on the D-x pin on the first 8 leading edges of BCLK-x after a FS-x leading edge. Also, it latches in data on the D-r pin on the first 8 trailing edges of BCLK-x after a FS-r leading edge. Note that FS-x and FS-r are the same in this application. Refer to the timing diagram in *Figure 2*.

Thus, it is seen that there is a timing difference in the way the codec and the Micro-wire interfaces work. However, as seen in *Figure 2*, if the shift clock, SK, to the Microwire interface is delayed with respect to BCLK-x, the two interfaces should work compatibly. This delay is accomplished by clocking BCLK-x through a shift register using MCLK-x as the clock source. This can be seen in the circuit schematic in *Figure 1*. (The author thanks Mr. Richard Lazovick for this suggestion.)

μ -LAW TO LINEAR/LINEAR TO μ -LAW CONVERSION

It was explained earlier that the codec outputs digital values that are companded using the MU-255 PCM standard. However, for linear PCM filtering applications, the input needs to be in linear PCM format. Similarly, it is necessary to provide the conversion from linear PCM to MU-255 PCM before output to the codec. The HPC accomplishes this in software.

1. μ -law to linear conversion. The codec output is actually the complement of the μ -law value. Thus, this first needs to be complemented to obtain the true μ -law value. The simplest way to obtain the corresponding linear value is through table look-up. The output of the table is the 16-bit 2's complement linear value. The sample program included with this report utilizes this technique. A macro that constructs this table is also provided.
2. Linear to μ -law conversion. An algorithm to convert a 13-bit positive linear number to 7-bit μ -law is described in *Figure 3*. The algorithm is based on the description in the book by Bellamy listed in the reference. The most significant 8th bit for the μ -law code is obtained from the sign of the input linear code.
1. Get 13-bit positive input value.
2. Add to it the bias value of 31-decimal.
3. The compressed μ -law word is then obtained as follows:

Biased Linear Value												
Bits												
12	11	10	9	8	7	6	5	4	3	2	1	0
0	0	0	0	0	0	0	1	Q3	Q2	Q1	Q0	a
0	0	0	0	0	0	1	Q3	Q2	Q1	Q0	a	b
0	0	0	0	0	1	Q3	Q2	Q1	Q0	a	b	c
0	0	0	0	1	Q3	Q2	Q1	Q0	a	b	c	d
0	0	0	1	Q3	Q2	Q1	Q0	a	b	c	d	e
0	0	1	Q3	Q2	Q1	Q0	a	b	c	d	e	f
0	1	Q3	Q2	Q1	Q0	a	b	c	d	e	f	g
1	Q3	Q2	Q1	Q0	a	b	c	d	e	f	g	h

μ -Law Value						
Bits						
6	5	4	3	2	1	0
0	0	0	Q3	Q2	Q1	Q0
0	0	1	Q3	Q2	Q1	Q0
0	1	0	Q3	Q2	Q1	Q0
0	1	1	Q3	Q2	Q1	Q0
1	0	0	Q3	Q2	Q1	Q0
1	0	1	Q3	Q2	Q1	Q0
1	1	0	Q3	Q2	Q1	Q0
1	1	1	Q3	Q2	Q1	Q0

FIGURE 3. 13-Bit Linear to 8-Bit μ -Law Conversion

POSSIBLE APPLICATIONS

The codec/HPC interface described above can be used in a number of speech processing applications. One application, ADPCM coding of speech, is presently under development. Other applications include: a voiced/unvoiced/silence classifier, a voice pitch tracker, speech detection circuitry etc. Note that the main limitation here (at least for real-time applications) is the amount of effective computation that can be done by the HPC between samples.

REFERENCES

1. National Semiconductor Corporation, *Telecommunications Databook*, Santa Clara, California, 1984.
2. National Semiconductor Corporation, *HPC Programmers Reference Manual*, Santa Clara, California, 1986.
3. National Semiconductor Corporation, *HPC Hardware Reference Manual*, Santa Clara, California, 1986.
4. J. C. Bellamy, *Digital Telephony*, John Wiley & Sons, New York, 1982.

The code listed in this App Note is available on Dial-A-Helper.

Dial-A-Helper is a service provided by the Microcontroller Applications Group. The Dial-A-Helper system provides access to an automated information storage and retrieval system that may be accessed over standard dial-up telephone lines 24 hours a day. The system capabilities include a MESSAGE SECTION (electronic mail) for communicating to and from the Microcontroller Applications Group and a FILE SECTION mode that can be used to search out and retrieve application data about NSC Microcontrollers. The minimum system requirement is a dumb terminal, 300 or 1200 baud modem, and a telephone.

With a communication package and a PC, the code detailed in this App Note can be down loaded from the FILE SECTION to disk for later use. The Dial-A-Helper telephone lines are:

Modem (408) 739-1162

Voice (408) 721-5582

For Additional Information, Please Contact Factory

APPENDIX A

PROGRAM TO TEST CODEC INTERFACE

NATIONAL SEMICONDUCTOR CORPORATION Page: 1
HFC CROSS ASSEMBLER, REV:C, 30 JUL 86
TSTCDC

```
1          ;
2          ;
3          ;          .TITLE TSTCDC
4          ;
5 01C0          YOFK = M(01C0)          ; OUTPUT SAMPLE STORAGE.
6 00C0          PSW = M(00C0)
7 00D0          ENIR = M(00D0)
8 00D2          IRFD = M(00D2)
9 00D4          IRCD = M(00D4)
10 00D6         SIO = M(00D6)
11 00D8         PORTI = M(00D8)
12 00E2         PORTBL = M(00E2)
13 00E3         PORTBH = M(00E3)
14 00E2         PORTB = W(00E2)
15 00F2         DIRBL = M(00F2)
16 00F3         DIRBH = M(00F3)
17 00F2         DIRB = W(00F2)
18 00F4         BFUNL = M(00F4)
19 00F5         BFUNH = M(00F5)
20 00F4         BFUN = W(00F4)
21 0188         T2TIM = W(0188)
22 0186         T2REG = W(0186)
23 018E         DIVBYL = M(018E)
24 018F         DIVBYH = M(018F)
25 018E         DIVBY = W(018E)
26 0190         TMMDL = M(0190)
27 0191         TMMDH = M(0191)
28 0190         TMMD = W(0190)
29          ;
30          ;
31          ;
32          ;          .MACRO MUTBL,STADR
33          ;
34          ; MACRO TO CREATE LOOKUP TABLE FOR MU-255 LAW PCM TO LINEAR CONVERSION.
35          ; STADR IS THE STARTING ADDRESS FOR THE TABLE, AND MUST BE AN EVEN ADDRESS.
36          ; THE TABLE OCCUPIES 512 BYTES.
37          ;
38          . = STADR
39          .SET SVAL,021
40          .SET INCRM,02
41          .DO 08
42              .SET MVAL,SVAL-021
43              .DO 010
44                  .WORD MVAL
45                  .SET MVAL,MVAL+INCRM
46              .ENDDO
47              .SET SVAL,SVAL*02
48              .SET INCRM,INCRM*02
49          .ENDDO
50          ;
51          .SET SVAL, 021
```

```

52             .SET INCRM, 02
53             .DO 08
54             .SET MVAL,SVAL-021
55             .DO 010
56             .SET RVAL,-1*MVAL
57             .WORD RVAL
58             .SET MVAL,MVAL+INCRM
59             .ENDDO
60             .SET SVAL,SVAL*02
61             .SET INCRM,INCRM*02
62             .ENDDO
63             ;
64             .ENDM
65             ;
66             ;
67             ;
68             .LOCAL
69 F000         MUTBL, OF000
70             ;
71 F200         .= OF200
72             CODEC:
73 F200 B701F0C4 LD SP, 01FO          ; INITIALIZE STACK POINTER.
74             ;
75 F204 3059    JSR INITCD           ; INITIALIZE THE CODEC
76             FLOOP:
77 F206 3005    JSR INPUT            ; GET INPUT SAMPLE, OUTPUT
78             ; PREVIOUS SAMPLE.
79 F208 E7      SHL A
80 F209 E7      SHL A
81 F20A 301F    JSR OUTPUT           ; CONVERT OUTPUT VALUE TO
82             ; MU-255 LAW AND SAVE.
83 F20C 66      JP FLOOP            ; 60 DO NEXT SAMPLE.
84             ;
85             ;
86             INPUT:
87 F20D B601C088 LD A, YOFK         ; GET DATA TO BE OUTPUT.
88             NOTDN:
89 F211 96D210  IF IRPD,0           ; IS MICROWIRE DONE?
90 F214 41      JP MWDONE           ; YES, SO GET DATA.
91 F215 64      JP NOTDN           ; NO, SO TRY AGAIN.
92             MWDONE:
93 F216 BED6    X A, SIO            ; GET NEW SAMPLE, OUTPUT
94             ; COMPUTED DATA.
95 F218 01      COMP A              ; TAKE CARE OF CODEC INVERSION.
96 F219 99FF    AND A, OFF
97 F21B E7      SHL A
98 F21C BAF000  OR A,OF000         ; FORM MU-LAW TO LINEAR
99             ; TABLE ADDRESS.
100 F21F AECE   X A, X
101 F221 D0     LD A, M(X+)         ; GET LINEAR VALUE
102 F222 AECA   X A, K

```

```

103 F224 04          LD A, M(X)          ; A BYTE AT A TIME.
104 F225 BCC8CB     LD H(K), L(A)
105 F228 ABCA       LD A, K
106 F22A 3C         RET
107                ;
108                ;
109                OUTPUT:
110 F22B 96D41F     RESET IRCD.7
111 F22E E7         SHL A              ; SIGN BIT TO C.
112 F22F 06         IFN C              ; IS IT POSITIVE?
113 F230 45         JP OPOS
114 F231 96D40F     SET IRCD.7
115 F234 01         COMP A
116 F235 04         INC A              ; NEGATIVE, SO TAKE 2'S
117                ; COMPLEMENT.
118                OPOS:
119 F236 B80108     ADD A, 0108          ; ADD BIAS.
120 F239 9107       LD K, 07          ; SET UP COUNTER.
121                ALIGN:
122 F238 E7         SHL A
123 F23C 07         IF C
124 F23D 44         JP ODONE          ; FOUND MS 1 BIT.
125 F23E AACA       DECSZ K
126 F240 65         JP ALIGN
127 F241 E7         SHL A              ; HAS TO BE 1 IN C NOW.
128                ODONE:
129 F242 AECA       X A, K
130 F244 E7         SHL A
131 F245 E7         SHL A
132 F246 E7         SHL A
133 F247 E7         SHL A              ; COUNTER VALUE IN BITS 4-6.
134 F248 AECC       X A, B
135 F24A 00         CLR A
136 F24B 88CB       LD A, H(K)
137 F24D 3B         SWAP A
138 F24E 990F       AND A, 0F
139 F250 96CCFA     OR A, B
140 F253 96D417     IF IRCD.7
141 F256 96C80F     SET A.7
142 F259 01         COMP A
143 F25A B601C08B   ST A, YOFK
144 F25E 3C         RET
145                ;
146                INITCD:
147 F25F B7FFB7F2   LD DIRB, OFFB7      ; SET B3 (T2IO) AND B6 (SK)
148                ; ON PORT B AS INPUTS. SET ALL
149                ; OTHER PINS ON B AS OUTPUT.
150 F263 B70000E2   LD PORTB, 0         ; OUTPUT 0 ON ALL PORT B PINS.
151 F267 96F40B     SET BFUNL.3        ; ALT. FUN. ON B3-T2IO.
152 F26A 96F40D     SET BFUNL.5        ; ALT. FUN. ON B5-S0.
153 F26D 96F508     SET BFUNH.0        ; ALT. FUN. ON B8-TS0.

```

```
154 F270 9700D0          LD ENIR, 0          ; DISABLE INTRPTS.
155 F273 9700D4          LD IRCD,0          ; SELECT SLAVE MODE FOR M-WIRE.
156 F276 83070188AB      LD T2TIM, 07       ; LOAD 7-DEC INTO T2 TIMER.
157 F27B 83070186AB      LD T2REG, 07       ; LOAD 7-DEC INTO T2 REG.
158 F280 8300018F8B      LD DIVBYH, 0       ; SELECT EXT, CLOCK FOR T2 TIMER.
159                      ;
160 F285 8ED6             X A, SIO
161 F287 8740400190AB     LD TMMD,04040      ; START TIMER T2.
162 F28D 3C              RET
163                      ;
164                      ;
165 FFFE 00F2             .END CODEC
```

TSTCDC

SYMBOL TABLE

A	00C8 W	ALIGN	F23B	B	00CC W	BFUN	00F4 W*
BFUNH	00F5 M	BFUNL	00F4 M	CODEC	F200	DIRB	00F2 W
DIRBH	00F3 M*	DIRBL	00F2 M*	DIVBY	018E W*	DIVBYH	018F M
DIVBYL	018E M*	ENIR	00D0 M	FL00P	F206	INCRM	0200
INITCD	F25F	INPUD	F20D	IRCD	00D4 M	IRPD	00D2 M
K	00CA W	MVAL	205F	MWDONE	F216	NOTDN	F211
ODONE	F242	OPOS	F236	OUTPUT	F22B	PC	00C6 W
PORTB	00E2 W	PORTBH	00E3 M*	PORTBL	00E2 M*	PORTI	00D8 M*
PSW	00C0 M*	RVAL	EDA1	SIO	00D6 M	SP	00C4 W
SVAL	2100	T2REG	D186 W	T2TIM	0188 W	TMMD	0190 W
TMMDH	0191 M*	TMMDL	0190 M*	X	00CE W	YOFK	01C0 M

NATIONAL SEMICONDUCTOR CORPORATION PAGE: 6
HPC CROSS ASSEMBLER,REV:C,30 JUL 86
TSTCDC
MACRO TABLE

MUTBL

NO WARNING LINES

NO ERROR LINES

656 ROM BYTES USED

SOURCE CHECKSUM = 81D3

OBJECT CHECKSUM = 0C3C

INPUT FILE C:CODECTST.MAC

LISTING FILE C:CODECTST.PRN

OBJECT FILE C:CODECTST.LM

TSTCDC
 SYMBOL TABLE

A	00C8 W	ALIGN	F23B	B	00CC W	BFUN	00F4 W*
BFUNH	00F4 M	BFUNL	00F4 M	CODEC	F200	DIRB	00F2 W
DIRBH	00F3 M*	DIRBL	00F2 M*	DIVBY	018E W*	DIVBYH	018F M
DIVBYL	01B3 M*	ENIR	00D0 M	FLOOP	F206	INCRM	0200
INITCD	F25F	INPUT	F20D	IRCD	00D4 M	IRPD	00D2 M
K	00CA W	MVAL	205F	MWDONE	F216	NOTDN	F211
ODONE	F242	OPOS	F236	OUTPUT	F22B	PC	00C6 W
PORTB	00E2 W	PORTBH	00E3 M*	PORTBL	00E2 M*	PORTI	00D8 M*
PSW	00C0 M*	RVAL	EDA1	SIO	00D6 M	SP	00C4 W
SVAL	2100	T2REG	D186 W	T2TIM	0188 W	TMMD	0190 W
TMMDH	0191 M*	TMMDL	0190 M*	X	00CE W	YOFK	01C0 M

Lit. # 100484

LIFE SUPPORT POLICY

NATIONAL'S PRODUCTS ARE NOT AUTHORIZED FOR USE AS CRITICAL COMPONENTS IN LIFE SUPPORT DEVICES OR SYSTEMS WITHOUT THE EXPRESS WRITTEN APPROVAL OF THE PRESIDENT OF NATIONAL SEMICONDUCTOR CORPORATION. As used herein:

1. Life support devices or systems are devices or systems which, (a) are intended for surgical implant into the body, or (b) support or sustain life, and whose failure to perform, when properly used in accordance with instructions for use provided in the labeling, can be reasonably expected to result in a significant injury to the user.
2. A critical component is any component of a life support device or system whose failure to perform can be reasonably expected to cause the failure of the life support device or system, or to affect its safety or effectiveness.



National Semiconductor Corporation
 1111 West Bardin Road
 Arlington, TX 76017
 Tel: 1(800) 272-9959
 Fax: 1(800) 737-7018

National Semiconductor Europe
 Fax: (+49) 0-180-530 85 86
 Email: cnjwge@tevm2.nsc.com
 Deutsch Tel: (+49) 0-180-530 85 85
 English Tel: (+49) 0-180-532 78 32
 Français Tel: (+49) 0-180-532 93 58
 Italiano Tel: (+49) 0-180-534 16 80

National Semiconductor Hong Kong Ltd.
 19th Floor, Straight Block,
 Ocean Centre, 5 Canton Rd.
 Tsimshatsui, Kowloon
 Hong Kong
 Tel: (852) 2737-1600
 Fax: (852) 2736-9960

National Semiconductor Japan Ltd.
 Tel: 81-043-299-2309
 Fax: 81-043-299-2408