

DATA MATION 75[®]

November

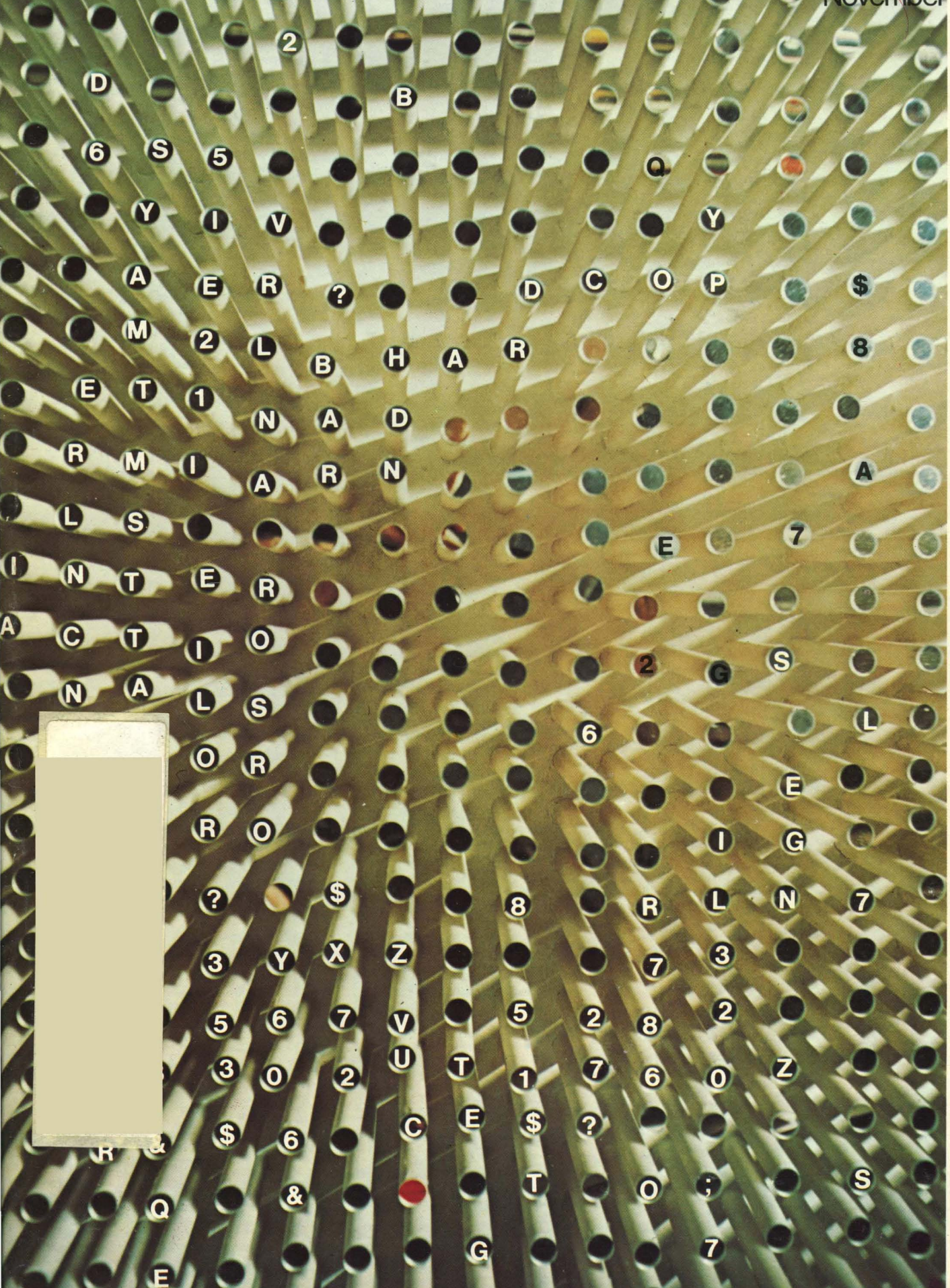

INTERACTIVE HARDCOPY TERMINALS
Also: IBM 5100, word processing, and system 370 reliability...

Datum Memory Systems at work!



A DATUM Magnetic Tape Memory System, one of more than 3000 installed to date . . . plays a vital role in the computer section of the Western Geophysical COBA 88 Vibroseis® buggy: 20 tons of rugged, precision prospecting equipment that gently shakes the earth by pressing down on a metal plate and vibrating at a controlled rate. Signals reflected from various rock layers are detected, digitized and recorded by equipment in the recording buggy (inset). DATUM provides mag tape systems to Digital Data Systems, who, in turn, supplies the larger systems to Western Geophysical.

For reliable response to rugged standards, specify DATUM magnetic tape or disk memory systems or controllers. Control as many as four disks or mag tape transports; handle multi-speed, multi-density (1600, 800, 556 and 200 bpi) tapes. You'll get immediate delivery for most minicomputers. Systems and controllers are compatible with your computer software; components plug together and into the computer for uncomplicated installation. Complete with controls, power supply, all necessary cables, diagnostic software and instruction manual.

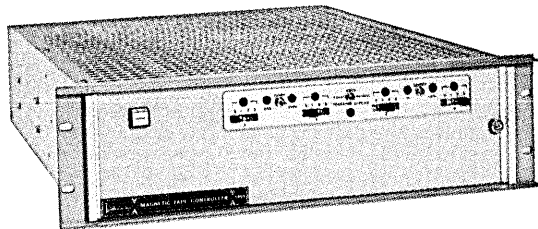

Datum Model 5091
Magnetic Tape Controller

Datum Disk or Mag Tape Memory Systems
Phone or write for specifications and prices

Peripheral Products Division

1363 S. State College Blvd., Anaheim, Ca 92806 • 714/533-6333
EUROPE: Datum House, Cranford Lane, Harlington, Middlesex,
UK • 01-879-0456

Datum inc

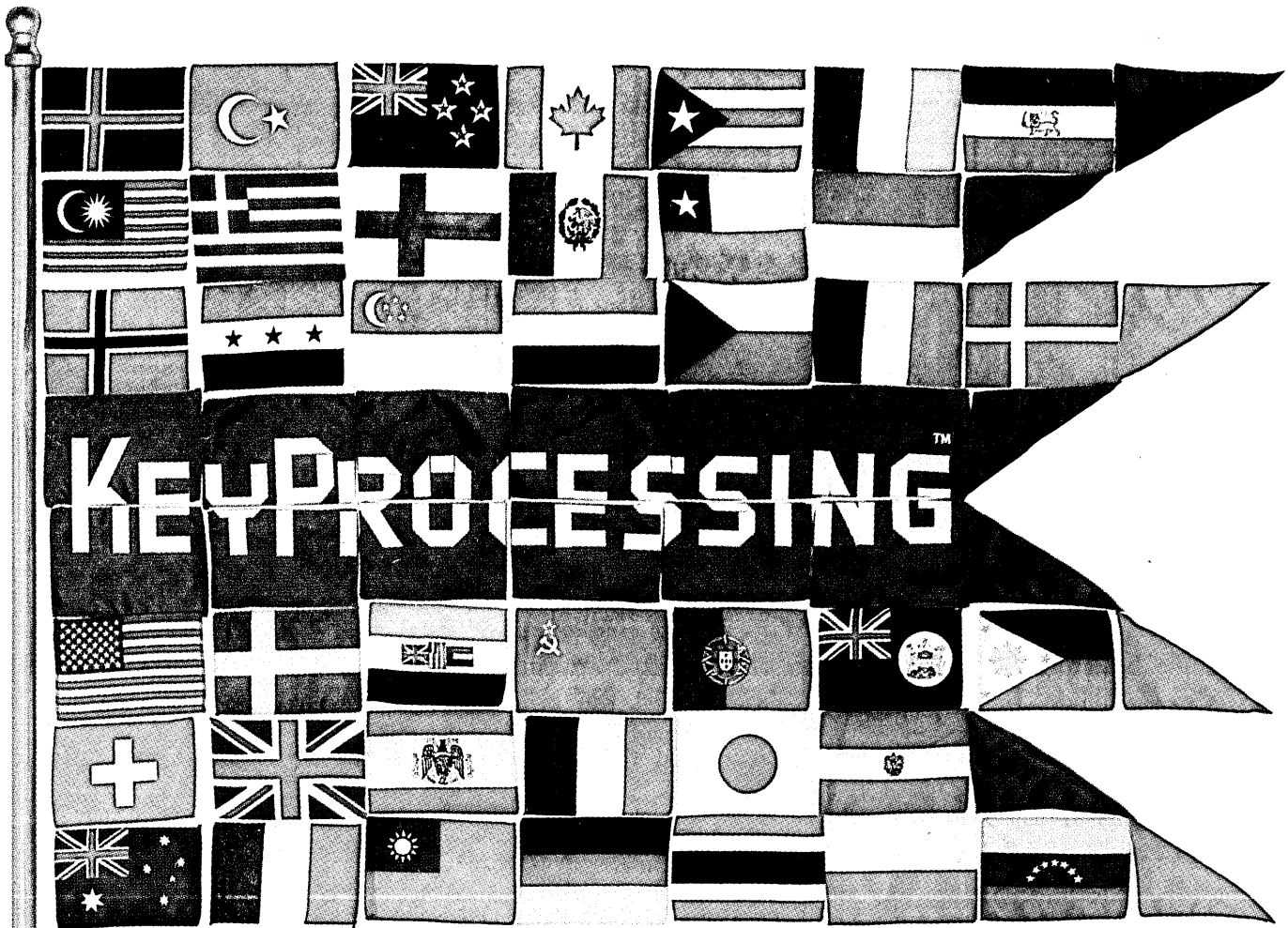

**Our name
will get to you**

**So will
our newest
KeyProcessing™
System**

The CMC 1800

Heralding the next generation

of data entry, the CMC 1800 does it all — foreground editing, background editing, remote job entry, and provides modularity for future growth — all at a price that's hard to beat.

The CMC 1800 starts small

with just a few keystations, storage for 25,000 80-character data records, and a processor with 64K bytes of core memory. But it grows big with storage for over 300,000 records, 160K bytes of memory, KOBOL™ (Keystation On-Line Business Oriented Language), RPG II, and up to 64 keystations.

The CMC 1800,

while the newest member of the KeyProcessing Family, is a family all by itself. It's cost effective for keypunch replacement applications, throughput oriented for high volume requirements, and sophisticated enough to handle today's jobs and tomorrow's challenges.

CIRCLE 4 ON READER CARD

CMC KeyProcessing Systems
are installed throughout the world.

Get to us,
you'll be pleasantly surprised.
Call or write today for more
information.

CMC

KeyProcessing is a trademark of
**Computer Machinery
Corporation**
2500 Walnut Avenue, Marina Del Rey
P.O. Box 92300
Los Angeles, California 90009
Telephone: (213) 390-8411

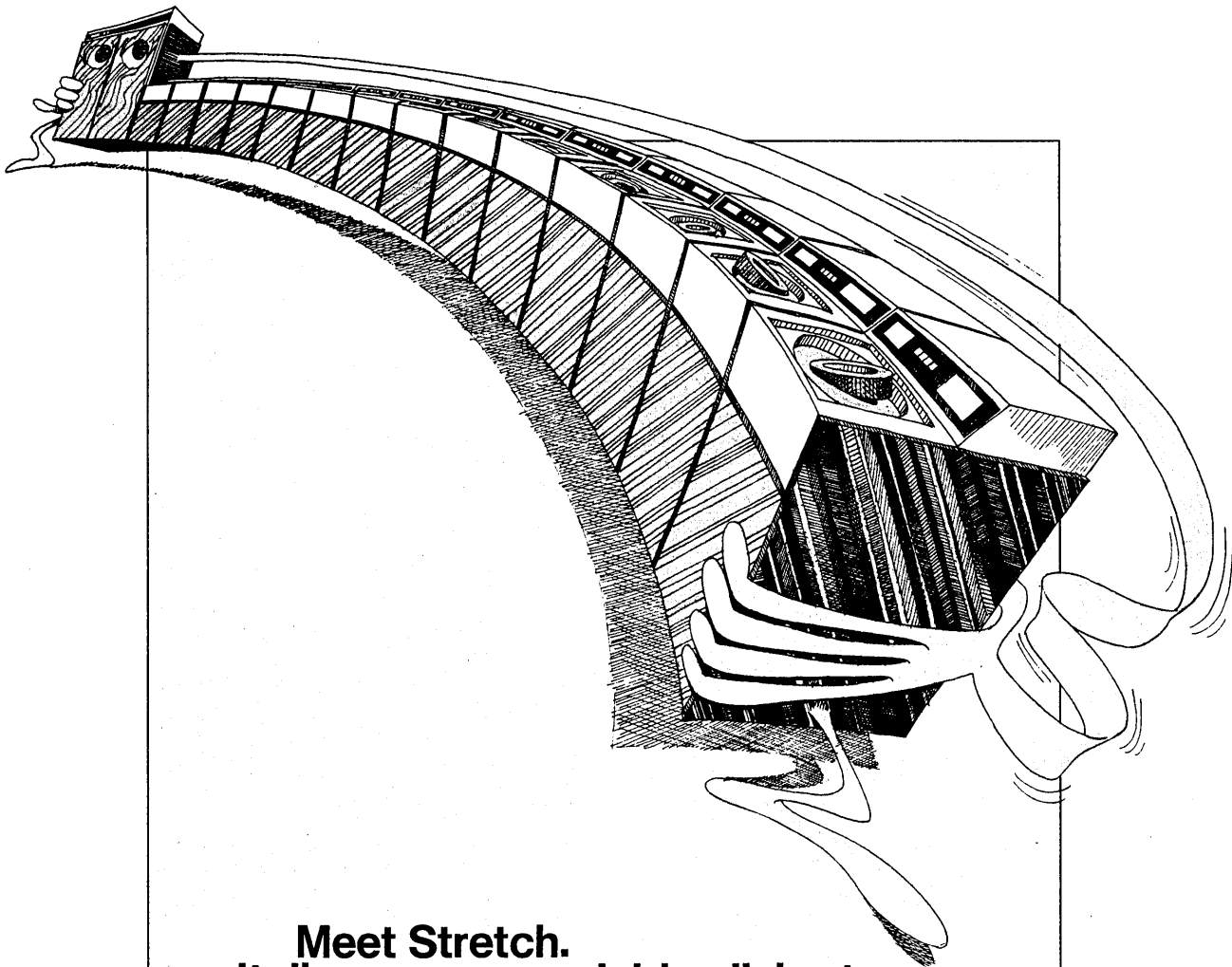

Meet Stretch.
Istel's new expandable disk storage subsystem. These days, nobody wants their capital tied up in storage capacity that's not used. But how do you pay for just the capacity you need?

With Istel's Stretch, Model 7833/7330, the new modular-design disk storage subsystem that grows with you.

Highly flexible in its configurations, Stretch consists of one or two storage control units with up to sixteen 100 or 200 megabyte disk drive units in any combination.

Start out with a subsystem of just the right size for your present requirements. Then, when you want more capacity, you simply add units. As often as necessary.

Fully plug-compatible with the IBM 3330, Istel's Stretch satisfies both today's direct access storage requirements and tomorrow's common data base needs in a multiple systems environment. At less cost.

At Istel, we couldn't have acquired over half a billion dollars in IBM computer leasing experience without making you a better deal.

Your financial alternative.

ITEL
CORPORATION
DATA PRODUCTS GROUP

One Embarcadero Center, San Francisco, California 94111. Phone (415) 983-0000

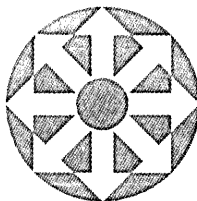

DATA MATION ⁷⁵®

VOLUME 21 NUMBER 11

This issue 121,257 copies

NOVEMBER 1975

FEATURES

Hardcopy Terminals

By 1980 the market for terminals will double, and the devices will account for 25% of hardware expenditures. By then crt's will have come to the fore. But hardcopy units are having their heyday now, and daisywheels, carousel cups, and matrix elements show how far the printing art has come since Gutenberg.

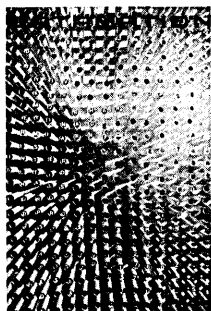

46 THE COMPUTER TERMINAL INDUSTRY: A FORECAST

Roy M. Salzman. Terminals will be a \$3 billion per year market by 1980. Watch for IBM and others to try to get an even tighter hold on what gets attached to their mainframes.

51 INTERACTIVE HARDCOPY TERMINALS

Jackson W. Granholm. They started something big when they attached a teletypewriter to a computer for the first time. Now there are nearly 40 companies and 70 product lines in the act.

62 THE TEN LAWS OF TELEPROCESSING

David Hebditch. As immutable as Murphy's Law, as immortal as the Peter Principle....

71 IBM's MINICOMPUTER, THE 5100

Michael Cashman. Hardware languages, built-in crt, and 64K of memory make the 5100 one of the most sophisticated and interesting products in years.

76 WORD PROCESSING AT DUN & BRADSTREET

J. M. Gaudette. An 80-computer network designed to give credit where credit is due.

82 WHEN NOT TO USE A DATA BASE

George Schussel. A data base can be too much of a solution for some problems.

106 TRACKING RELIABILITY AND AVAILABILITY

C. H. Reynolds and J. E. Van Kinsbergen. For all the vendor's claims of "system assurance," IBM 370 hardware and software is little better than the second generation.

117 IBM AND THE INDUSTRY

Can IBM control the careers of its users? If so, that's another reason to have a user Ombudsman.

178 THE FORUM

Thomas R. Gildersleeve. Structured programming is being oversold. On the other hand, decision table proponents need a new public relations agent.

NEWS IN PERSPECTIVE

122 ANTITRUST

The issue of bigness. Telex vs. IBM: the risk was too great.

123 RETAILING

Point-of-sale: stiff competition. VUVM takes off like a tortoise.

130 MEMORIES

They write in ink, don't they?

132 MAINFRAMERS

Honeywell modifies charges on used computer software.

135 ELECTRONIC FUNDS TRANSFER

Study of the inevitable.

137 SECURITY

Horror stories are funny — but!

138 SOFTWARE

Software design: a Pisa perspective.

140 COMMUNICATIONS

Oh to be in the South in March. Tomorrow's dollars are from hardware.

142 STANDARDS

IBM's the standard for I/O interface.

143 MINICOMPUTERS

Computer store is "frantic and fun."

146 BENCHMARKS

For the Xerox users; Business is good; From Russia and China; ICL joins CPI; "Understandable but unfortunate; Bid rigging charges; Rodgers' view.

DEPARTMENTS

7 LETTERS

The need for a Company Bastard, reminiscing about the 704, Ershov vs. Solzhenitsyn, and more.

11 PEOPLE

J. Gerry Purdy: helping the human race; Lynda and Francine Yaker: IBM's distaff doubles.

17 LOOK AHEAD

22 CALENDAR

Dp & education, Interface '76 preview, calls for papers.

27 SOURCE DATA

Books on the U.S. computer industry and on general systems thinking reviewed; minicomputer reports & others; vendor literature, book briefs, and courses.

45 EDITOR'S READOUT

A visit to the front lines: the dp department vs. the users.

152 HARDWARE

A Univac competitor for the 370/125 and /135; a talking calculator; and an interesting ocr page reader design.

164 SOFTWARE & SERVICES

A new from the ground up information management system called NOMAD; 360/370 real-time system tuning.

170 ADVERTISERS' INDEX

ABOUT THE COVER. This month's cover is constructed to symbolize the interactions involved in receiving and transmitting data via hardcopy terminals. Sculpture is by Barbara Benson. Photography by Andy Cominos.



GREEN TAG VALUE

MINICOMPUTER MEMORY... Buy 1/2...Get 1/2 Free

You get up to twice as much memory for your money from EMM. It's like only paying for half, and getting the other half free. And that's just one of the reasons why it pays to do business with the memory experts. You get the choice of core or semiconductor, the latest advances in memory system design, and a full one-year warranty.

Come to EMM for add-in/add-on memory for most major mini-computers — DEC, Data General, Interdata, General Automation and others. You'll get more bits for your buck — and proven performance too — when you deal directly with the memory experts at EMM.

TYPICAL PRICES*

Minicomputer Model	Capacity	Minicomputer company price	EMM Price
Data General Nova 1200	8K Words	\$2000	\$860
	16K Words	\$3500	\$1230
	32K Words	Not Avail.	\$2400
Interdata 7/16, 7/32	32K Bytes	\$5000	\$2000
General Automation SPC-16	16K Words	\$4600	\$2000
DEC PDP-11	32K Words	\$9800	\$5190

*All prices for single unit quantities.

EMM ELECTRONIC
MEMORIES
COMMERCIAL MEMORY PRODUCTS

A Division of Electronic Memories & Magnetics Corp.
12621 Chadron Ave., Hawthorne, Calif. 90250 (213) 644-9881

DATAMATION.

EDITORIAL STAFF

Editor	John L. Kirkley
Articles Editor	Richard A. McLaughlin
International Editor	Angeline Pantages
European Editor	Nancy Foy
Communications Editor	Phil Hirsch
Industry Editor	W. David Gardner
Products Editor	Michael Cashman
Source Data Editor	Daniel P. Schlosky
Calendar Editor	Gloria Tidstrand
Reprints Editor	Laura R. Ochinerio
News Editor	Tom McCusker
Bureau Managers	
San Francisco	Edward K. Yasaki
Los Angeles	Edith D. Myers
Washington, D.C.	Phil Hirsch
	Pamela Evans
New York	Angeline Pantages
New England	W. David Gardner
Correspondents	
Minneapolis	James K. Johnson
Southwest	Robert F. Alexander
Australia	Frederick A. Bland
Editorial Advisor	Robert L. Patrick
Technical Advisor	Lowell Amdahl
Contributing Editors	Paul Armer, Howard Bromberg, Philip H. Dorn, Louis B. Marienthal, Ray W. Sanders, Milton R. Wessel, F. G. Withington

EDITORIAL OFFICES

Headquarters: 1801 S. La Cienega Blvd., Los Angeles, CA 90035. Phone (213) 559-5111. Eastern: 35 Mason St., Greenwich, CT 06830, (203) 661-5400. 134 Mt. Auburn St., Cambridge, Mass. 02138, (617) 354-2125; 9805 Singleton Dr., Bethesda, MD 20034, (301) 530-7271. Southwestern: 2711 Cedar Springs, Dallas, TX 75201. (214) 744-0161. Western: 2680 Bayshore Frontage Rd., Suite 401, Mountain View, CA 94043, (415) 965-8222. Foreign: 8 Pellerin Rd., London N. 16; (01) 249-1177; 64/90 Blues Point Rd., McMahons Point, NSW 2060, Australia.

GRAPHIC DESIGN & PRODUCTION

Art & Production Director	Cleve Marie Boutell
Advertising Production Manager	Marilee Pitman
Production Assistant	Alberta R. Martin
CIRCULATION	
35 Mason Street, Greenwich, CT 06830	
Circulation Manager	Suzanne A. Ryan
Marketing Research Manager	Deborah Dwellley
Publisher	James M. Morris
Assistant Publisher	F. Douglas De Carlo
Circulation audited by Business Publications Audit	

Member  American Business Press, Inc.



DATAMATION is published monthly on or about the first day of every month by Technical Publishing Company, 1301 South Grove Ave., Barrington, Illinois 60010; Arthur L. Rice, Jr., Chairman of the Board; James B. Tafel, President; Gardner F. Landon, Executive Vice President.

Executive, Circulation and Advertising offices, 35 Mason Street, Greenwich, CT 06830, (203) 661-5400. Editorial offices, 1801 S. La Cienega Blvd., Los Angeles, CA 90035. Published at Chicago, Ill.

DATAMATION is circulated without charge by name and title to certain qualified individuals who are employed by companies involved with automatic information handling equipment. Available to others by subscription at the rate of \$24; \$40 Air Mail annually in the U.S. and Canada. Reduced rate for qualified students, \$14. Foreign subscriptions are available for £16.80 or for the equivalent of \$40 U.S. in most West European currencies. Sole agent for all subscriptions outside the U.S.A. and Canada is J. B. Tratsart, Ltd. 154 A Greenford Road, Harrow, Middlesex HA13QT, England. No subscription agency is authorized by us to solicit or take orders for subscriptions. Controlled circulations paid at Columbus, OH and Form 3579 to be sent to Technical Publishing Company, P.O. Box 2000, Greenwich, CT 06830. © Copyright 1975 Technical Publishing Company. © "Datamation" registered trademark of Technical Publishing Company. Microfilm copies of DATAMATION may be obtained from University Microfilms, A Xerox Company, 300 No. Zeeb Road, Ann Arbor, Michigan 48106. Printed by Beslow Associates, Inc.

DATAMATION

Bell & Howell's Optical Mark Readers. The beauty of the system is in the simplicity behind its data entry concept. Our OMR reads a pencil mark from a source document directly into computer-ready information. It requires no special skills, no manual keying, no duplicate transcribing and no cumbersome manual edit procedures. And the bottom-line savings are dramatic.

A simple case underlines the point. A major telephone company installed a Bell & Howell Intelligent Mark Reader terminal to process trouble reports and dispatch repair crews. As information is received on the phone, a tab-card trouble report is marked by pencil, placed in the IMR terminal, and automatically checked for errors. The information is then reformatted and transmitted to a central computer where

Let's see how simple it is to start saving time and money. Please send me your brochure.

I'd like a representative to call.

Name _____

Title _____

Company _____

Address _____

City _____ State _____ Zip _____

Phone _____



BELL & HOWELL

Business Data Products Division, 360 Sierra
Madre Villa, Pasadena, CA 91109. 213-796-9381.

the data is routed to the appropriate service center. The IMR terminal takes 3 hours to provide 100% error-free data entry. The same job originally required 40 hours manual keying, with an unknown error factor. The per-installation salary savings are about \$1000 a month. Valuable connect-time requirements dropped from 15 hours monthly to one hour—a savings of around \$170 a month per installation. Think of these savings for every one of 28 installations!

Our Optical Mark Readers are up, running and saving in thousands of installations all over the country—doing jobs such as inventory control, order entry and trouble reporting. Our OMR can save you a lot of time and money, too. It's as simple as that.

For a brochure describing our OMR products, fill out the coupon and mail.

Here's how simple data entry is with OMR.

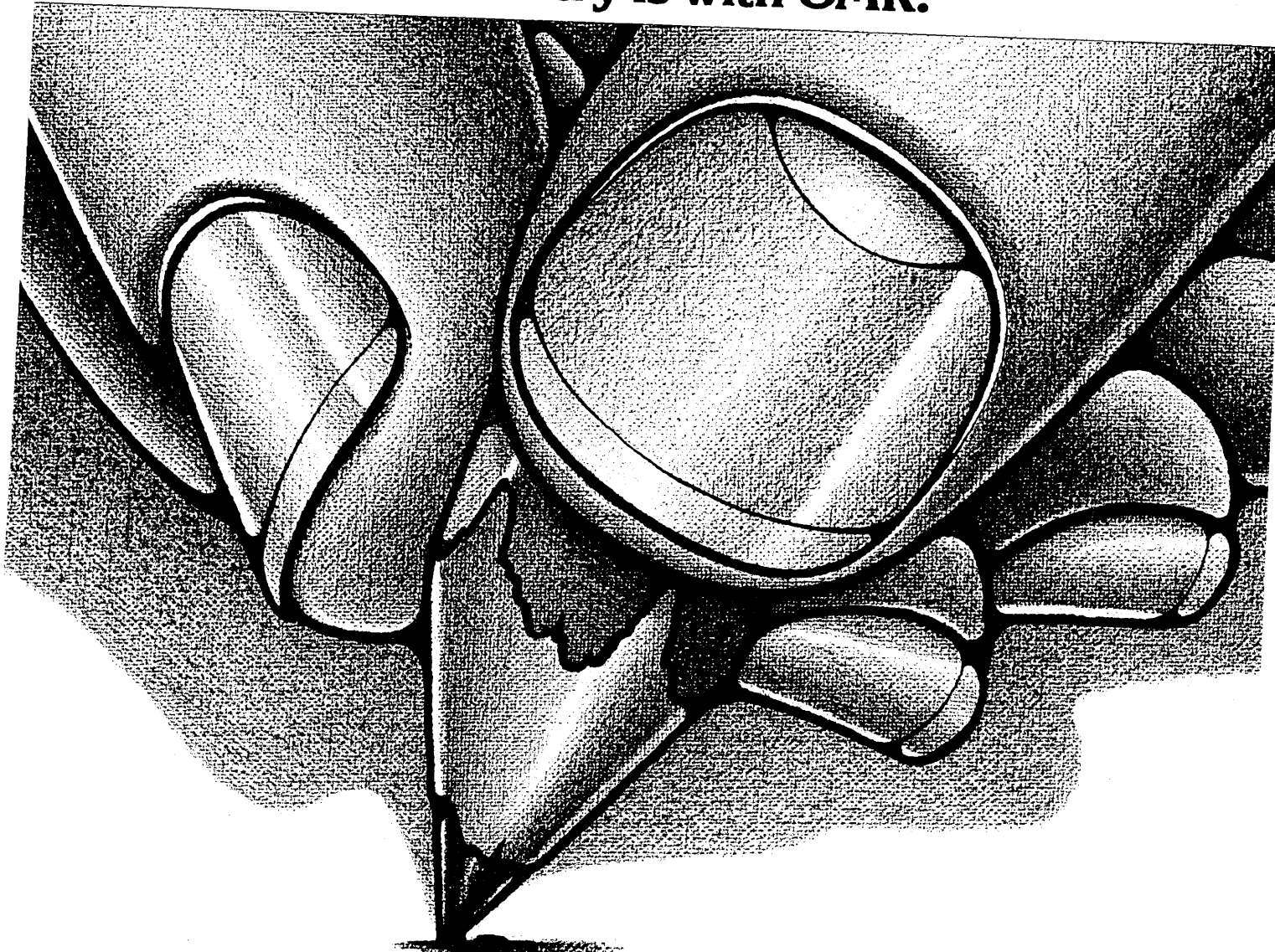

Time was when high speed printing meant a high speed line printer.

Times have changed.

And so have printers. No longer is high speed line printing the sole realm of the expensive line printer.

Centronics has changed all that. Our new 103 and 503 serial impact printers can give

you up to 340 lines per minute. Not only are they the fastest, most efficient serial impact printers you can buy, but, in some applications, they can keep pace with line printers costing twice as much.

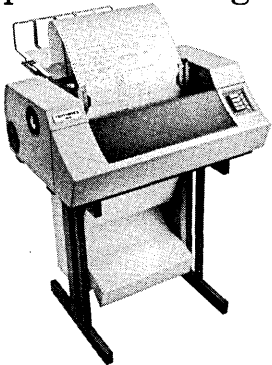

How do they do it? By a unique combination of printing speed, slew rate and intelligence. Both the 103 and the 503 are 165-character-per-second, 132-column printers.

Both are bidirectional — which is the intelligence part. They print right-to-left, left-to-right at 70 to 340 lines per minute. Moving to the nearest character on the next line to be printed — wherever it may be. There is no carriage return and no carriage return deadtime (in the 400 milliseconds it takes to effect a carriage return, these printers print 80

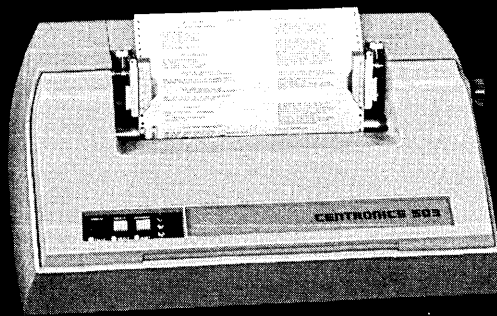

characters). A big boost for throughput.

If performance is why you buy a printer, you want to learn more about our model 103. If economy is your thing, the model 503 gives you the best

performance for the money anywhere. Our catalogs and spec sheets give you complete information. Send for your copies today.

We want to change your mind about printers. Centronics Data Computer Corp., Hudson, New Hampshire 03051.

CENTRONICS® PRINTERS

ATTN: Marketing Services
Gentlemen,
Tell me more about your high speed printers.
The 103 and the 503.

- Send catalogs and spec sheets.
- Have a salesman call.

Name _____
Title _____
Company _____
Address _____
City _____ State _____ Zip _____

letters

New Title: Company Bastard

Trevor Swanson's *Devil's Advocate* (July, p. 113) is a collection of persons I have called "The Company Bastard." No one person can do the job well—its scope is much larger than that proposed by Swanson. The CB pokes his nose into everything that goes on, not just the new (and not just in dp, either, in my view). And no one person can do it for very long.

Anyone whose principal tool is hard-to-answer questions (e.g., What are you doing? Why are you doing it? How do you know you're accomplishing what you set out to do?) is likely to end up like good old Socrates—except that the hemlock will not be self-administered. So, at one time or another, everyone in an organization should have to be the CB. Let it be a temporary assignment, duration to be determined by circumstances.

In one instance of the use of the technique, the most competent programmer and the best-liked one in the group was turned into an outcast, placed in Coventry by his former "friends" and associates, in only five weeks. They wouldn't even have lunch with him. It was they who coined the name "The Company Bastard"!

ROBERT M. GORDON
Director
Computing Services Center
Victoria Univ. of Wellington
Wellington, New Zealand

Let's ask Xaviera Hollander . . .

In the September issue (p. 7), William A. Delaney offered his criteria for determining professionalism. His own apparent lack of professionalism in that undertaking was significant enough to induce me to respond to what I would otherwise consider a proper topic for cocktail parties.

My previous sentence uses the word "professionalism" to mean a measure of how well one does whatever he does. According to Mr. Delaney, however, most medical researchers, for example, are not professional because they are not their own bosses. On the other hand, a clerk-typist who derives interest from her savings account satisfies his condition that the professional has more than one source of income. I could criticize his other points similarly, but have neither the desire nor the space. In any event, these are minor criticisms compared to that of noting that he omitted entirely any considera-

tion of performance.

However, being the charitable fellow that I am, I can read between the lines and infer that Mr. Delaney actually shares my opinion about the whole issue, namely, that the concept is intrinsically arbitrary and thus has no pragmatic value. His criteria illustrate this belief. I really do hope that was his intention. Otherwise, I am embarrassed to have read this discourse in one of my "professional" journals.

MARVIN J. GINSBURG
Computer Specialist
Insurance Inst. for Highway Safety
Washington, D.C.

. . . or John Havlicek

According to William A. Delaney's "rules of thumb" for a professional, I suppose the Boston Celtics could represent the U.S.A. in the Olympic basketball competition.

W. R. JINES
Dallas, Texas

SHARE-ing 704 stories . . .

Congratulations on your fine article, "The IBM 704" (Aug. p. 45). There was quite a discussion about it at the last SHARE meeting among those who were part of the story, and the consensus was that it covered a majority of the important facts and did a splendid job of capturing the flavor of that corner of computing history.

As you might expect, however, there were a great many quibbles over some



of the statements that were made, covering the spectrum from readily established questions of fact to highly subjective opinions.

In discussing the first meeting of SHARE in Los Angeles, you stated "Frank Wagner was the president." Much as I would like to have had that honor, it belongs to Jack Strong of North American Aviation. I am quite willing to share with him and Paul Armer the honor of being the founding fathers of SHARE, but I did not become president until a few years later.

Given confidence by the success of SHARE . . . Jack Strong went on to become a founder of GUIDE, and rallied numerous activists in GUIDE to the

strong support of the first CODASYL committee. Strong's flair for diplomacy and reconciling antagonistic factions had a lot to do with the early acceptance of the whole COBOL idea. So even the great world of business data processing probably owes a good deal to the catalytic function of the 704!

FRANK WAGNER
Senior Vice President
Informatics Inc.
Woodland Hills, Calif.

. . . about what the kids missed

The nostalgic item on the IBM 704 brought a tear to my eye as the "Good Old Days" came into focus once again. Not only was there a TXI command but a TXI as well, not to mention programmable sense lights. No os, just a two- (binary) card loader in the front of your deck did it all. Zowie! I tell you that these kids nowadays just don't know what REAL automation is.

HANS W. NINTZEL
Branch Manager
MRI Systems Corp.
Dallas, Texas

But the kids are catching on

I read that you give free subscriptions to qualified persons, so . . . I am 11½ years old and I can program in BASIC, a little FORTRAN, and in COBOL and machine language. I have access to a PDP-8 Edusystem (BASIC language) computer and my father and I are building an Altair 8800 (Intel 8080 microprocessor) computer. It will only have machine language when we get it built, but we are buying a BASIC language package for it.

I have written about 100 programs in BASIC, about 22 FORTRAN, 16 COBOL, 20 in machine language . . . so far.

I plan to be doing a lot more programming in the near future, and I am always looking for new ideas for programs.

Am I qualified?

KURT INMAN
Scotts Valley, Calif.

Damn right you are! You've now become Datamation's youngest subscriber.

Lost in a review loop

Your two-sentence review of Henry Lucas' book *Why Information Systems Fail* (July, p. 28) ended with the observation that it "will appeal most to psychological researchers" (as opposed to computer people, presumably).

The whole point of the book is that computer people tend to concentrate on technical matters and overlook the "people" problems which invariably

letters

are part of any systems effort. By delegating the entire matter to psychological researchers, your reviewer did far more than overlook the problem. He shows he would not recognize it if it hit him in the face.

Not much has been thoughtfully written on this subject. Whatever its merits, Lucas' book is at least a start.

RONALD S. KINTISCH
Executive Services, Inc.
Abington, Pennsylvania

The "Book Briefs" included in our "Source Data" department are intended only to make readers aware of interesting new books. A more comprehensive review of Lucas' work is already underway. Now maybe we should commission a review of that review?

But Solzhenitsyn says . . .

The first sentence of Mr. Ershov's "A History of Computing in the U.S.S.R." (Sept., p. 80) caught my attention because of its conspicuous exaggeration and the contrast between it and Mr. Alexander Solzhenitsyn's comments in his recent talk on June 30 in the Ballroom of the Washington Hilton. Mr. Ershov says, "The Soviet Union has been forced to develop all aspects of

the computer business relying exclusively on its own intellectual and technological resources." Mr. Solzhenitsyn said, ". . . we observe continuous and steady support by the businessmen of the West of the Soviet Communist leaders. Their clumsy and awkward economy . . . is continually getting material and technological assistance . . . from the West."

I decided to pursue the seeming contradiction further and found some very specific information in Mr. Stanislaw Wasowski's book, *East-West Trade and the Technology Gap* (New York: Praeger, 1970). The following comments are found on pages 63-64 of that book: "Computer technology in the Soviet Union is virtually entirely imported from the West. In the early 1930s, the Soviet Union was importing unit record equipment . . . The SAM business machine plant was established in Moscow in 1932 and began to produce copies of Western machines. This practice of copying earlier models of Western machines continues to the present time. . . . The point to be made is that literally all significant technological innovations in computer technology have occurred in the West. Advances in Soviet computer technology have been, without significant exception, direct transplantations."

Behind the glaring contradictions of

these generalities from Messrs. Ershov and Wasowski are the details from which they were derived. For example, Mr. Ershov in his table of software development in the U.S.S.R. indicates 1966 as the time of delivery of the first operating systems. In 1970, Mr. Wasowski writes (p. 60), "The development of large integrated software packages such as IBSYS or 360/os is unknown in the Soviet Union. Software systems to support multiple programming, time-sharing, interactive programming, computer graphics, and other sophisticated applications have yet to be developed in the U.S.S.R."

JACKSON D. PEMBERTON
Systems Analyst
Salt Lake County Data Processing
Riverton, Utah

Multi-mini systems too

I was sorry that Mr. Carren in his fine article, "Multiple Minis for Information Management" (Sept., p. 54), did not include some general background information about multi-mini systems like CHAMPS.

The fact is that while software and experience still lag hardware developments, multi-mini systems stand head and shoulders over the old fashioned centralized computer in applications of this type. Not only do they cost far less to purchase, program, and install than a single computer with multiple time-sharing terminals, but their response time is considerably better. A small computer dedicated to local processing reacts a lot faster than a large computer that handles many different applications.

What's more, several minis can be interconnected as an effective hedge against down time. Mr. Carren's comments on reliability are sufficient testimony to this fact.

But most important is the ease of system expansion. Each mini can be installed, programmed, and started before going to the next. Programming and interfacing problems are usually local. Hardware can be added without halting operation and new software can be brought up off-line and transferred to those computers on which it is to be run.

THOMAS E. GUIDONE
Senior Programmer
AG-Data Processing
West Point, New York



DATAMATION does not publish unsigned letters. However, we will withhold a writer's name or address upon request with sufficient reason. Readers are also welcome to correspond on a not-for-publication basis. Write to 1801 S. La Cienega Blvd., Los Angeles, CA 90035.

TIRED OF THE TIME-SHARE GLITCH?

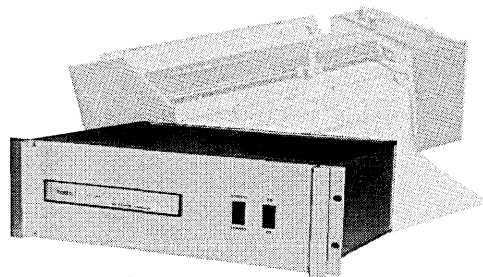

If you're suffering from plot-error problems you need a PTC-5

The new PTC-5, double buffered, Plotter Time-share Controller with its error detection retransmission capability gives error-free plots. It is totally interruptible without loss of origin. Microprocessor decodes plot vectors and generates alphanumeric characters to reduce connect time, CPU time, and cost to a minimum. Priced from \$1945.00.

**houston
instrument**

DIVISION OF BAUSCH & LOMB

ONE HOUSTON SQUARE (at 8500 Cameron Road) AUSTIN, TEXAS 78753
(512) 837-2820 TWX 910-874-2022 cable HOINCO

TELECOPIER EUROPEAN OFFICE Phone 059/277445 Telex Bausch 81399
Rochesterlaan 6 8240 Gistel Belgium

"the recorder company"

CIRCLE 90 ON READER CARD

STARAN translates a satellite's winks into wheat forecasts.

Every time the Landsat satellite winks, it takes a picture. And by analyzing these pictures, crop forecasters will attempt to determine wheat acreage.

But the job of digesting the billions of bits of data in these images can give even powerful conventional computers indigestion. That's why NASA uses Goodyear's STARAN® associative parallel array processor.

Ordinary digital computers process only one or a few discrete

points of an image at a time. But the STARAN system combines content addressability with parallel array arithmetic to process hundreds, or even thousands, of image points at once.

And because this unique capability dramatically speeds operations, massive improvements in image throughput are possible. That's why the STARAN processing system is unmatched in its ability to solve problems requiring operations

on many similar data streams or high-speed searches of many similar file records.

So before you invest a lot of money in an image processing system, invest a little time. Look into STARAN. The more severe your requirements, the more money it may save you.

For complete information, just write to Wayne Brubaker, Goodyear Aerospace Corporation, Akron, Ohio 44315. Or call him at (216) 794-3631.

CIRCLE 72 ON READER CARD

GOODYEAR
AEROSPACE

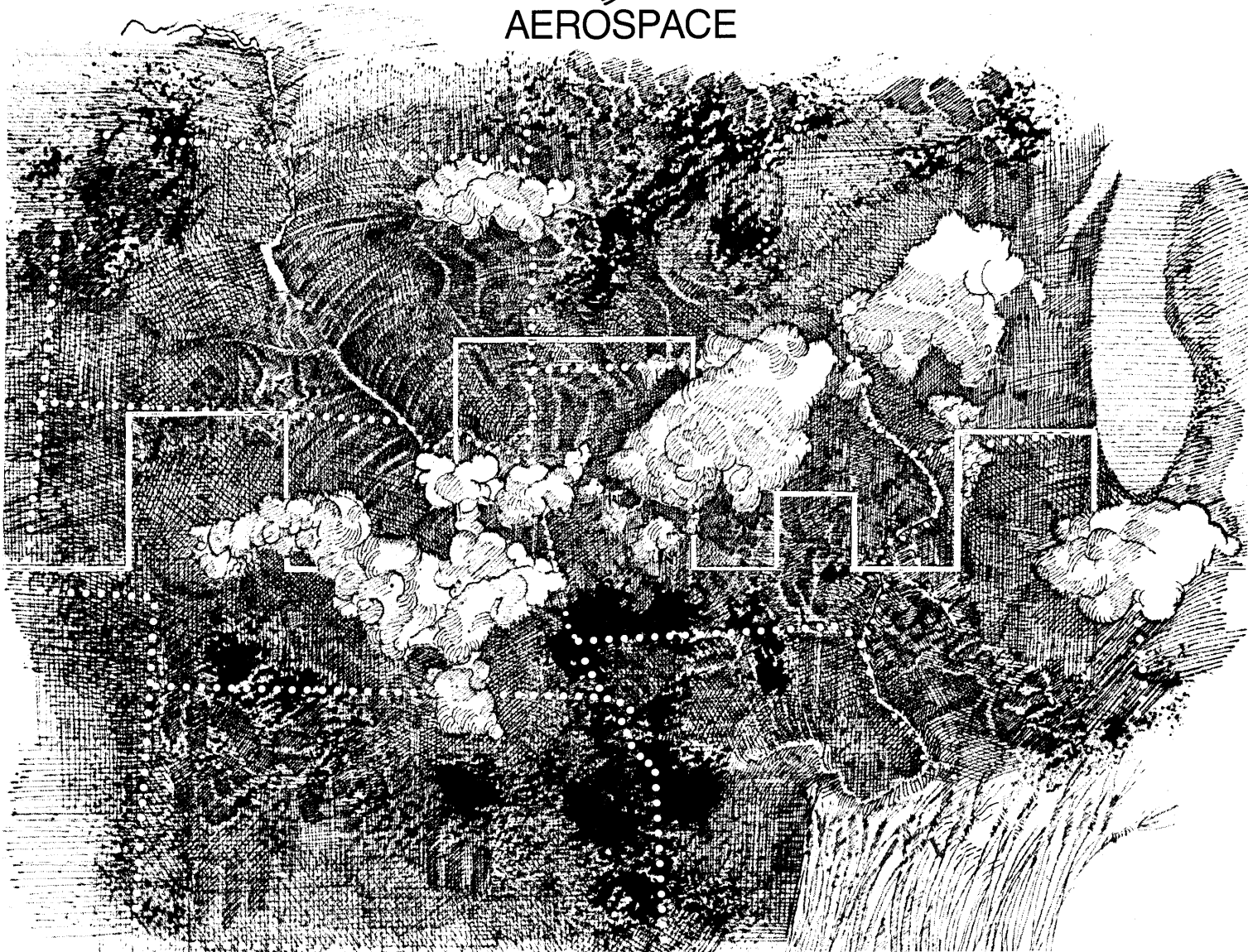

HOW TO GET YOUR PACKAGE THERE AS FAST AS IF YOU CARRIED IT YOURSELF.

It's as easy as 1, 2, 3.

1. Bring your small package to United's passenger check-in counter 30 minutes before flight time. Pay the charges.

2. Phone your addressee. Give him the flight number, arrival time, and receipt number.

3. Thirty minutes after arrival, the package can be picked up at the baggage claim area.

How big is small?

Up to 50 pounds in weight, up to 90 inches in total dimensions (length, plus width, plus height).

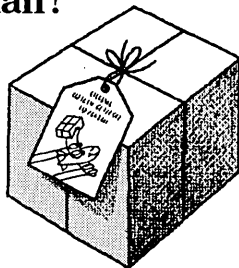

What can you ship?

Things like film, computer tape, samples, medicine, advertising material, blueprints . . . or the briefcase you forgot to take on your business trip.

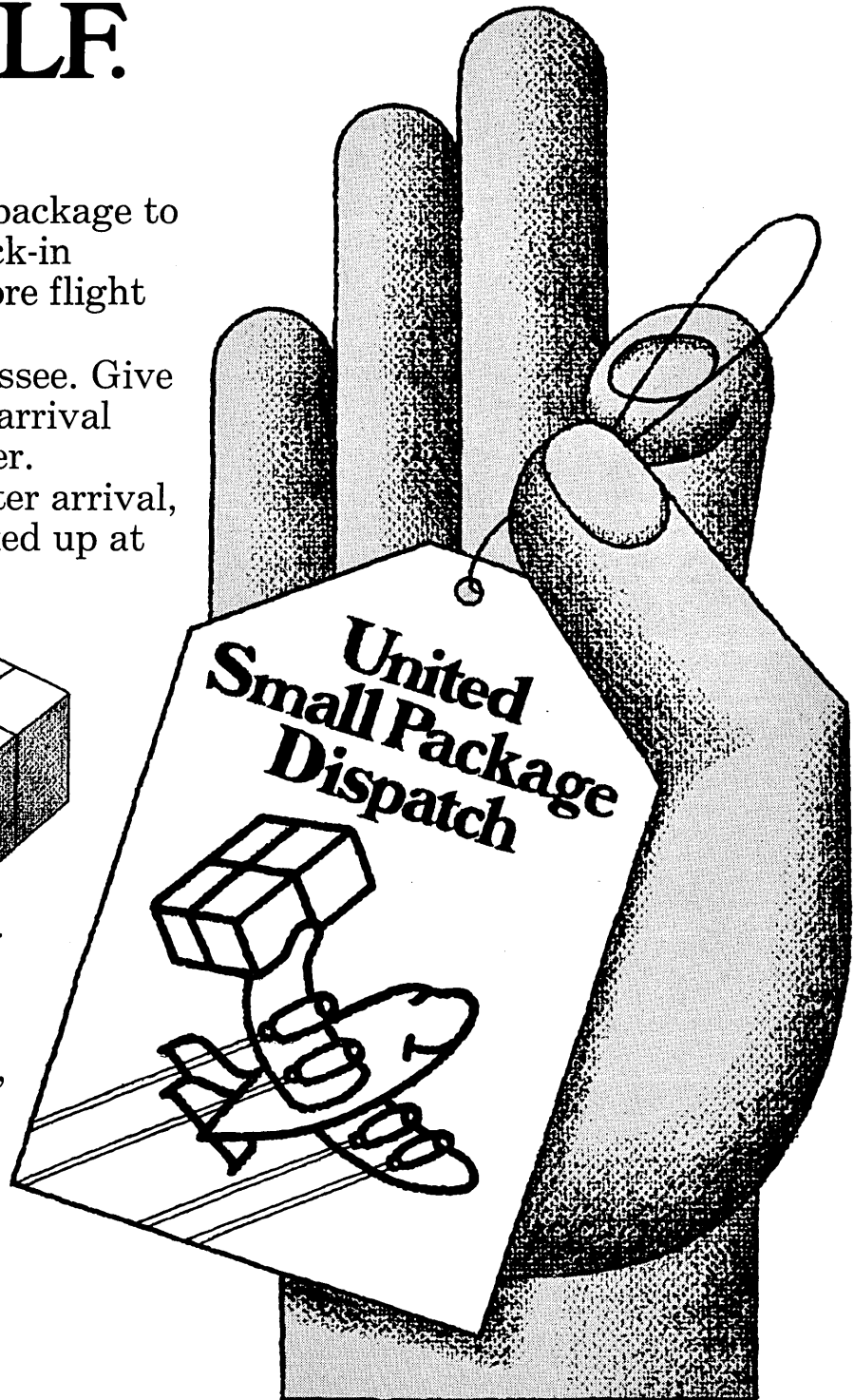

No.1 in the U.S. sky

 **UNITED AIRLINES CARGO**

people

Likes Helping the Human Race

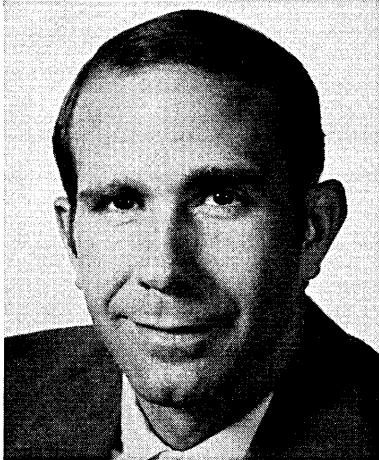

J. GERRY PURDY
... a believer in exercise

J. Gerry Purdy is a man who believes in exercise. He believes exercise produces fitness and good health. He's a computer scientist. He likes the idea of computer use "helping the human race out in some way."

What he is and what he likes and believes fits well with his job. He's director of information systems for the Arizona Heart Institute in Phoenix. He's been on this job for about eight months and he's excited about it. The big thing now with Purdy and his staff of six at AHI is the CDR (Cardiovascular Data Repository) project. They're designing and beginning to implement an on-line patient information system for heart patients.

Purdy said AHI has built a data base of from 10 to 20 megabytes of information in the past two and one-half years. He expects this will go to from 100 to 500 megabytes in the next five to ten years. "I don't know of any other heart center in the world that is collecting as comprehensive a data base on cardiovascular disease as we are though there are some that are collecting subsets of what we are compiling."

When Purdy first joined AHI he felt he could do it all in 12 months. Now he says his on-line, 40 to 60 terminal system will be up and running "within the next two years."

Xerox Corp.'s pull-out from the computer business was a bit of a set-

back. AHI had been using a Motorola-owned Xerox Sigma 9. "On Sept. 26, they said we were too much of a burden for them." Purdy has been thinking in terms of an XDS 560 for his own system. "If we could have gone to a 560, conversion would have been trivial. Now we have to re-think the whole thing. I guess a lot of people who had been looking at Xerox are sitting in the same place I am."

Although AHI has from six to nine months in which to select a hardware vendor, Motorola's Sept. 26 decision has forced faster evaluation. They need to get time and preferably on a computer compatible with the one they'll eventually use. Purdy said he is looking for a manufacturer who will: be around for the next five to ten years; have a computer locally available; and can offer what "I need and want for my kind of job."

He is looking most closely at Honeywell, Digital Equipment Corp. and Univac. Honeywell has a major plant in Phoenix. Ramada Inns has a Decsystem 10 there and Arizona State Univ. has an applicable Univac machine. What Purdy

wants most is a good data base management system. "With the volume of information we will have, to be able to control it in a transaction processing environment, you've got to have data base management."

Arizona Heart Institute is an organization headed by Dr. Edward B. Dietrich, which combines patient treatment with education and research. On the education side it offers fellowship programs in cardiovascular surgery and cardiology. There also is a cardiovascular nurse specialty program. The institute does two kinds of research, basic research involving animals, conducted in conjunction with Arizona State University, and clinical research, involving people, which is headed by Purdy's information systems group. Data collected includes the results of cardiovascular screening which basically is exercise stress testing. "People are put on treadmills then given an EKG." The results go into the data base. So does the "fitness factor" determined by the length of time a patient can keep up the treadmill activity. "Our system will collect data on patients

(Continued on page 12)

IBM's Distaff Doubles



LYNDA (LEFT) AND FRANCINE YAKER
"... double the pleasure"

Although outgoing, El Paso-born Lynda Yaker doesn't seem to think there is anything too unusual about herself. Others might disagree.

For openers, she's a Systems Engineering Manager in IBM's Dallas Data Processing Div., and she has an identical twin who is a systems engineer for IBM in Houston.

Being blonde, attractive and looking even younger than her 30 years, Lynda admits to getting double takes when meeting customers and co-workers for the first time.

She was not sure of the statistic but opined that there are not many women in Dallas of her age group in IBM management. (She may be in a smaller minority than she realizes. The article, "Women Speak Out On DP Careers" in the August '75 DATAMATION states, "In IBM ... fewer than 5% of all managers are women ...")

Raised by parents who drew no stereotyped roles for men or women and taught their children to be in-

(Continued on page 12)

Helping the Race

over a long period of time. Heart disease is chronic." This data also includes treatment and results which "has a bootstrapping effect . . . can lead to modifications of treatment . . . better ways to treat and solve heart disease problems."

AHI is not Purdy's first involvement with the combination of computers and health. His previous position was as director of computer technology for Dr. Kenneth H. Cooper's Institute for Aerobics Research. Among other things this institute has assigned "aerobic points"

to various forms of exercise. Purdy says he still chalks up 300 aerobic points a week, jogging some 4 miles every day.

Although he now runs only for "pleasure and health" he used to be more competitive. While working for his M.S. in computer science at UCLA (he also earned a Ph.D. at Stanford) he regularly entered long distance races. "I'm not a good runner. The only trophies I ever got were for handicap runs." Purdy is co-author of a book for runners which has sold about 10,000 copies. Using a computer he developed scoring tables and pacing tables

which tell a track runner how to run in workouts.

He is interested in other sports too and was author of a DATAMATION article, "Sports and EDP . . . It's a New Ballgame" (June 1, '71 p. 24). And his research has led to computer generated Olympic decathlon scoring tables which he will submit this fall to the National Amateur Athletic Union. "If they approve, they'll take it to the international body and maybe my tables will be used in the next Olympics." He contends the current decathlon scoring system is "regressive and unfair to the athletes." *

Distaff Doubles



dependent, Lynda Yaker sees herself as a qualified person, doing work she loves, and notes "no particular reaction" to her being a woman. On occasion, she detects a hint of surprise because she doesn't look older, but that passes quickly when the job at hand comes under discussion.

It may be a good thing there are nearly 300 miles between their offices since, with the Yaker twins, identical means "identical." Lynda and sister Francine look alike, walk alike, sound alike and act alike. At one point in their undergraduate careers, they were taking seven math courses between them and only the head of the department knew that this ambitious "student" was two people. One befuddled professor spent the year in confusion, noticing "her" everywhere at once in the math department, seemingly

switching outfits several times in every given day.

They started college together at the University of Texas, but later separated to avoid "getting lumped as one." Francine continued at the University of Texas and Lynda transferred to San Diego State College. By the time both ended up at the University of Houston (one and one-half years later), each had set her own social and academic pace, was comfortable with it, and looked at minor mix-ups as more fun than problem.

Lynda had found it was easy to keep geared up mentally and maintain a high average when she carried a 20-some-hour semester load. She finished college in three years, graduating in 1966. Francine preferred the four-year route. Math majors both, the Yakers stem from the just-past "dark ages" when most universities did not offer many courses, to say nothing of degrees, in computer science. Lynda had one college course, programming, and Francine had four, including programming and systems.

Lynda's first job after college was with a Houston aerospace company, working mainly on orbit determination trajectory evaluation projects for the Gemini and Apollo programs.

After three years on the pro-

grams, she went to IBM in El Paso as a systems engineer. In 1972, she became a marketing support center representative in Los Angeles and, since October 1974, she has been a systems engineering manager in Dallas, among the youngest of her peers.

Francine joined IBM in 1973 as a systems engineer, then transferred to Houston in 1975, after having done computer science research for an oil company and development projects for a computer manufacturer.

Lynda says she has "loved every stage of my work so far" but, like many good technicians before her, gladly "laid down my tools to move into management."

As a systems engineering manager, she enjoys much business travel. "Working with men and women all over the country lets you get below the surface amenities," she reports. "You see different life styles and points of view," one of her many job bonuses, she believes.

Like the Wrigley Doublemint ads, the Yaker twins have doubled their pleasure and their professional careers; and without waving the flag of women's lib to any great degree, they have proved they can hold their own and grow professionally in an industry that has few women managers . . . thus far. *

In New Posts

DOUGLAS A. DAVIDSON was elected senior vice president of Mohawk Data Sciences Corp. . . . CHESTER R. SMITH, data processing manager for Chemtron Corp., Chicago, was named "Man of the Year" by the Computer Lessors Assn. . . . DON M. MULLER is the new president of the Peripheral Equipment Div. of Pertec Corp. . . . DAVID J. NOONAN was appointed vice-president of Marine Management Systems, Inc.,

Stamford, Conn. . . . LARRY MAYHEW, general manager of the Information Display Group of Tektronix, Inc., has been named a group vice president of the company . . . LINDSAY L. BAIRD, JR., general manager of Advanced Security Techniques, a division of Advanced Computer Techniques Corp., was selected national chairman, computer security committee of the American Society for Industrial Security . . . MICHAEL BLASI was named data processing vice president for W. T. Grant Company. *

MOVE OVER 1403. THE 2550 IS HERE.

Make room for the Dataproducts 2550 horizontal-font printer.

Until recently, the IBM 1403 train printer has been the industry standard for quality printing at 1100 lines per minute (LPM).

But now the 2550, with the Charaband® print drive, sets a new standard at 1500 LPM.

Or, 36% faster than the 1403.

Horizontal Font Printing

The Charaband is a horizontal-font carrier that offers all the advantages of train printers, and eliminates the disadvantages of sliding friction.

The 2550, combining the Charaband with our patented Mark IV hammer, offers a highly reliable friction-free print mechanism.

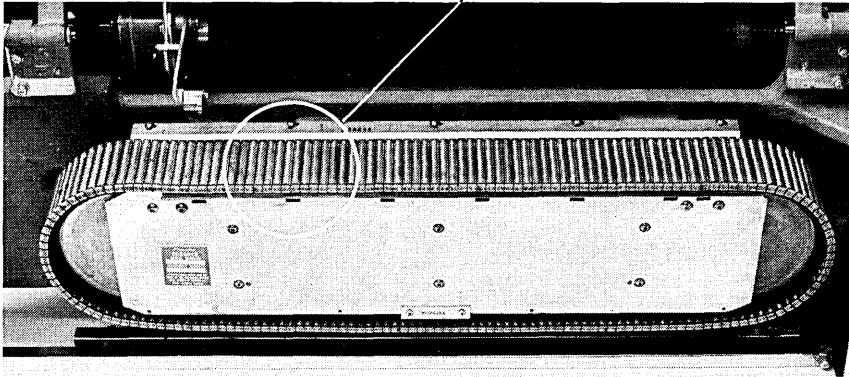

In short, consistent, straight-line, high quality printing.

Reliability Plus

The Charaband is driven on a roller bearing system to eliminate sliding friction and lubrication systems.

And, unlike train printers, very little wear occurs in the print mechanism.

Reliable operation— equals much less down time.

On-the-job Flexibility

The Charaband carries two complete fonts—one on each side.

The fonts are reversible.

The 2550 also offers replaceable character-type modules that don't require a cartridge readjustment.

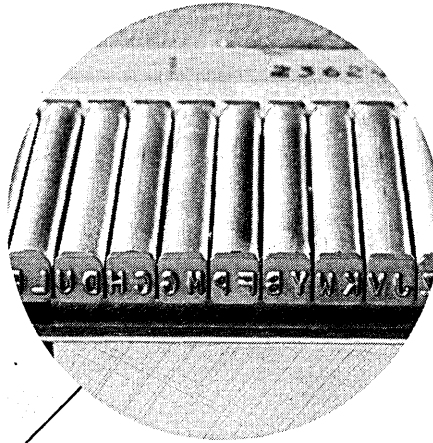

A 90° swing-open gate for easy access to Charaband, ribbon and paper.

And simplified controls built into your own "quietized" cabinet.

The 2550 Costs Less

It costs less than the 1403.

Yet, its exclusive Charaband design is a clear-cut improvement in line printer technology.

How do we do it?

Simply by specializing.

Dataproducts is the leading independent printer manufacturer in the world.

And by concentrating in one technology, we are able to make a better printer.

For less than the competition.

Our 2550 Charaband printer is 1500-LPM proof of that claim.

Interface Compatible

The 2550 can be interfaced with almost every major computer system that requires high-speed performance.

So we invite you to call or write for full information and specs.

Remember, Charaband horizontal-font, 1500-LPM speed, less down time and less money.

Little wonder the former industry standard has to move over.

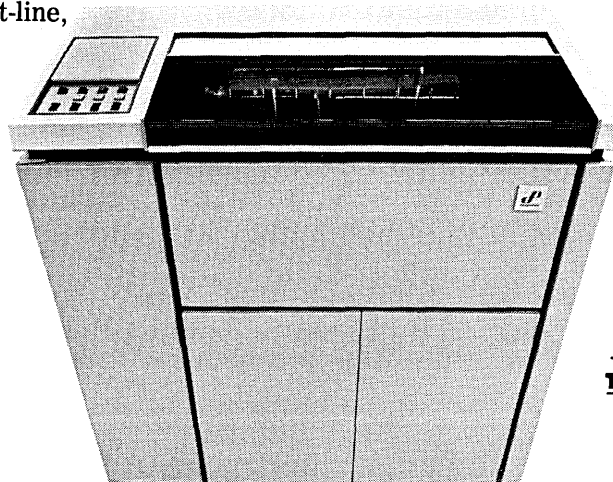

Dataproducts
The Line Printer Company

6219 De Soto Avenue/Woodland Hills, Calif. 91364/Telephone (213) 887-8451/887-8147

THE BEST, AND GETTING BETTER:

A proven system with more than two years of hard field use at many organizations, DATASHARE has demonstrated its ability to disperse computer power to field offices for many tasks, sharply improving employee productivity while reducing operating costs. But at Datapoint we haven't rested on our laurels. Our DATASHARE is constantly being improved. Consider these facts.

A FULLY PROGRAMMABLE, MULTI-USER SYSTEM

DATASHARE is a fully programmable, multi-user system using a powerful processor and a line of peripherals to match your needs. Using the Datapoint 5500 processor with 48K user memory, 16 users can simultaneously access the system and accomplish data entry, data processing, file management or report generation. Programming can be quickly accomplished in DATASHARE language. Each user can run a separate program and access single or multiple public or restricted files. There's no spinning wheels trying to make a limited system fit specialized needs—DATASHARE's inherent flexibility and powerful software lets the user at each remote site readily accomplish the task at hand.

WITH VIRTUAL MEMORY

Optimum productivity from any computer system requires an

2, etc. There's no need for tedious time consuming file conversion routines to use DATASHARE files in other applications or with other non-DATASHARE Programs.

EASY FILE BACK-UP

Many competitive systems are oblivious of the real business need for keeping duplicate files, offering only relatively primitive capability for file duplication or back-up. DATASHARE's Operating System allows a convenient means to duplicate entire disk files and utilities for cassette-disk, tape-disk or disk-disk duplication procedures, allowing crucial back-up files to be easily made.

CONCURRENT COMMUNICATIONS/PROCESSING

Datapoint processors have long been noted for their powerful communications packages, whereby program and data files can quickly be transferred between processor sites. Similarly DATASHARE now offers the ability to transmit and receive data files while the field system users continue using DATASHARE for standard applications. Files may now be sent to a central home office or other computer site without any interruption to normal ongoing usage.

Likewise, as with any computer system, there's a need to create new programs, to debug, to run utilities or other batch operations. With DATASHARE's concurrent processing

can cross the country with a DATASHARE network. And you can have one or more DATASHARE ports used as a dial-up facility sequentially accessed by an unlimited number of field users. To make field office usage even simpler, all DATASHARE hardware and software is operator-oriented with a minimum of controls. The 3600 user-terminal, for example, has a straightforward typewriter style keyboard and easy to read non-glare display.

PROGRAM FLEXIBILITY

Thousands of DATASHARE installations in field locations have demonstrated the flexibility and cost effectiveness that a proven system can provide. But there's another important advantage to DATASHARE usage—program interchange. Programs written for your DATASHARE can also be used in the popular Diskette 1100 Intelligent Terminals. With this capability, programs need not be restricted only to DATASHARE sites but can be used for those applications whenever a single-user stand-alone system such as a Diskette 1100 is utilized. Also, programs written for the Diskette 1100 will run in the multi-user DATASHARE system.

ADAPTABILITY—DATASHARE'S MIDDLE NAME

Another nice thing about DATASHARE is its ready adaptability

Don't settle for second best. Set your sights on

Operating System that allows user programs to exceed the main memory size. Most large mainframe systems today use virtual memory techniques, and so does DATASHARE. Up to 512 K characters (bytes) of space may be shared among the maximum 16 DATASHARE users such that each user is assured a 32K program space.

DYNAMIC FILE MANAGEMENT

Any business processing system worth its salt needs a file structure that users can work *with* easily, not have to work *around* arduously. The files generated on the DATASHARE system are totally dynamic—which means that users can easily create new files without regard to file length or use of complex file tables. Also, files can be combined, added to or deleted without complex techniques or system considerations. And DATASHARE files are compatible with other Datapoint programs such as DATAFORM, DATABUS, BASIC, RPG

capability the system manager can do all these, can run RPG 2, BASIC or DOS Utilities from the central processor console while the system's terminal users still enjoy full access. With this capability, new system development, or "odd jobs" don't have to wait for off-hours.

REMOTE OR LOCAL USER TERMINALS

DATASHARE user terminals can be placed up to 2,000 feet away from a central 2200 or 5500 processor using simple twisted pair connections. But if there's a need to go further, the terminals can be hooked to modems or acoustic couplers and standard dial-up telephone lines using conventional hardware. In fact you

to your company's needs and requirements. In some organizations, it may serve as an independent computer utility, providing computer power for a multitude of applications to its work stations. In others, the user terminals may serve strictly for data entry, editing and pre-processing of field data so that a large central computer can function most efficiently. For some users, the powerful independent processing at dispersed work stations is the attraction. For others, it's the ability to structure very tightly a computerized approach for previously manually handled chores. Or it can be a combination of all of the above. Adaptability—DATASHARE's middle name and another good reason why it's the best yet.

So don't settle for second best. Go with the most advanced, most proven dispersed processing network on the market—DATASHARE. For more information, contact the Datapoint sales office nearest you, or write or call Datapoint Corporation, attention: Marketing Communications, 9725 Datapoint Drive, San Antonio, Texas 78284 (512) 690-7151.

DATAPPOINT CORPORATION



The leader in dispersed data processing

Home Office: 9725 Datapoint Drive, San Antonio, Texas 78284 (512) 690-7151 • Sales Offices: Atlanta/(404) 458-6423 • Boston/(617) 890-0440 • Chicago/(312) 298-1240 • Cincinnati/(513) 481-2600 • Cleveland/(216) 831-0550 • Dallas/(214) 661-5536 • Denver/(303) 770-3921 • Des Moines/(515) 225-9070 • Detroit/(313) 478-6070 • Greensboro/(919) 299-8401 • Hartford/(203) 677-4551 • Houston/(713) 688-5791 • Kansas City/(913) 321-5802 • Los Angeles/(213) 645-8400 • Milwaukee/(414) 453-1425 • Minneapolis/(612) 854-4054 • Union, N.J./(201) 964-8761 • New York/(212) 736-3710 • Orlando/(305) 896-1940 • Philadelphia/(215) 667-9477 • Phoenix/(602) 265-3909 • Pittsburgh/(412) 931-3663 • Portland/(503) 233-2411 • San Diego/(714) 460-2020 • San Francisco/(415) 968-7020 • Seattle/(206) 455-2044 • Stamford/(203) 359-4175 • St. Louis/(314) 878-6595 • Tulsa/(918) 664-2295 • Washington, D.C./(703) 790-0555 • International: TRW/Datcom—International/Los Angeles, California, TELEX 691286 (213) 475-6777 • Sydney, Australia/(2) 922-3100 • Vienna, Austria/(0222/36 21 41 • Brussels/3762030 • Rio de Janeiro, Brazil/222-4611 • Toronto/(416) 438-9800 • Copenhagen/(02) 965-366 • Guayaquil, Ecuador/394844 • London/(1) 903-6261 • Helsinki/90-661 991 • Paris/(1) 657-13-31 • Hanover, Germany/(0511) 634-011 • Rotterdam/(10) 2182-2182 • Hong Kong/(5) 243-121 • Tel Aviv, Israel/(03) 410565 • Milan/316 333 • Tokyo/264 6131 • Beirut/(348) 340/1/2 • Oslo/153490 • Makati Rizal, The Philippines/877294 • Singapore/911788 • Tehran, Iran/8538857 • Johannesburg/724 9301 • Las Arenas, Spain/63 64 00 • Stockholm/(8) 188295 • Lyss Berne, Switzerland/(32) 844240 • Taipei, Taiwan/768-1114

Datashare

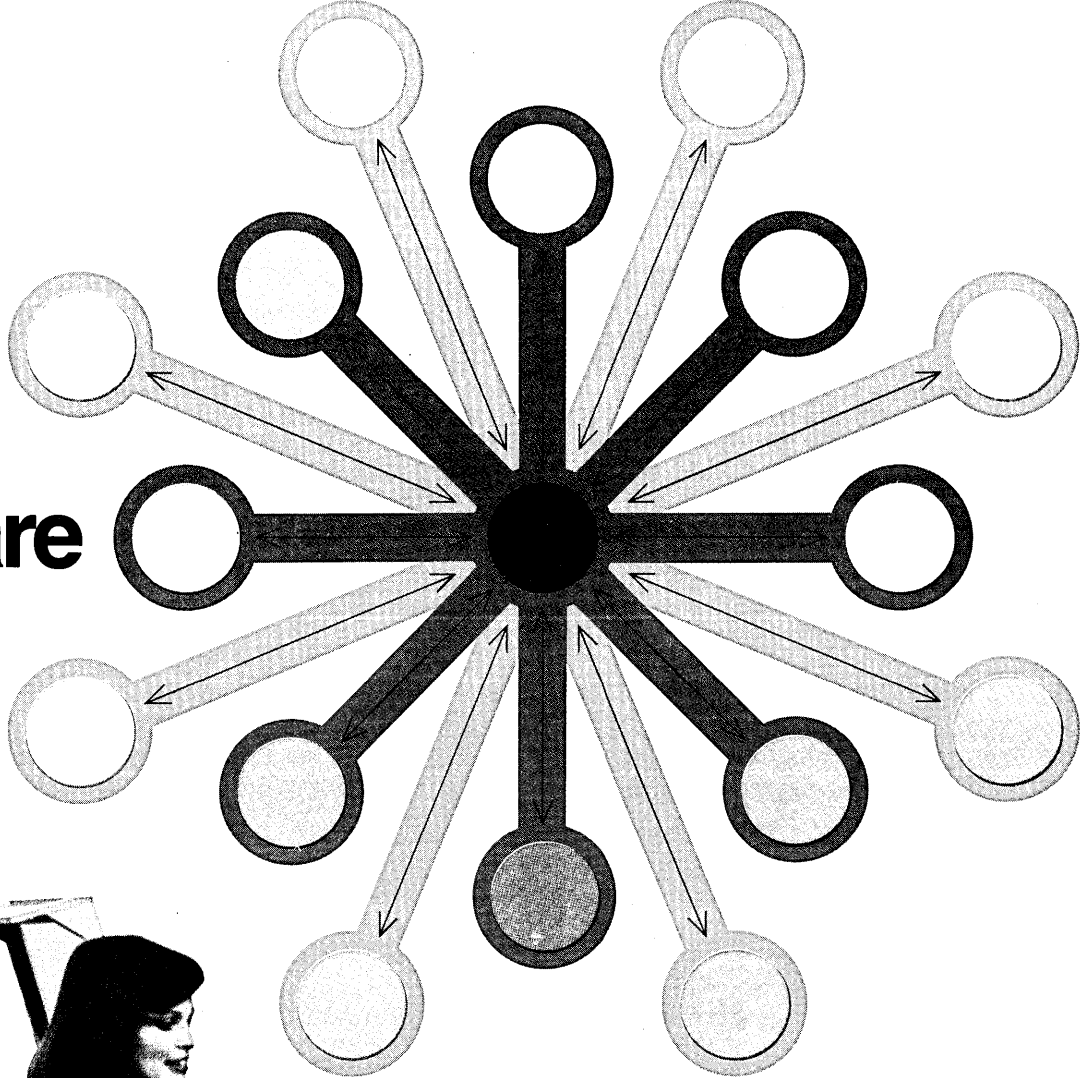

BASF has it. Why wait?



Now you can get the 3348, or "Winchester," Data Module, with all the quality and error-free performance that the name BASF implies . . . and at a competitive price.

The "Winchester" Data Module is a completely self-contained unit, incorporating heads, spindle, and recording surfaces in a protective factory-sealed pack. You've heard of the advantages of this new technology . . . complete security from environmental contamination, improved high-density storage, and incredibly fast access. Now you can enjoy this premium performance without paying a premium price.

Here are the facts, in brief:

- Complete compatibility with 3340 drives
- BASF-guaranteed Zero-Error performance
- Now available in two configurations. . . The 1335 Module, with 35 million-byte capacity, and the 1370 Module, with 70 million-byte capacity
- Our 1370F Module, with fixed head and quicker access, will be available later.

For complete details on the BASF "Winchester" Data Module, write: BASF Systems, Crosby Drive, Bedford, MA 01730, or call our nearest regional office . . . in **Los Angeles**, (213) 451-8781; in **Chicago**, (312) 343-6618; and **Clifton, NJ** (201) 473-8424.

You're already paying for BASF quality..you might as well have it.

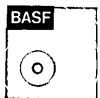

CIRCLE 12 ON READER CARD

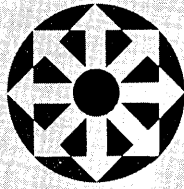

LOOK AHEAD

HONEYWELL MAKES ANCHORS?

Honeywell Information Systems apparently tried to be vague about its newly-instituted software charges at a meeting of its users group in Cleveland in late October. Honeywell's marketing director for Eastern operations, Millard Allen, told the group at a special session on the subject that he was attending the meeting as a pinch hitter for another Honeywell executive who had formulated the company's policy on levying licenses and other charges on software of Honeywell computers that are sold secondhand through third parties (p. 132). But he promised to get the details for them at a later date.

However, after a reporter (from *Datamation*) offered to produce them, a copy of the policy and prices suddenly materialized from HIS staffers in the audience. And an angry user complained: "You're actually contracting your base (by making it difficult for users of purchased equipment to sell it). Honeywell wants users to go (up) to the 6000, but we'll sell our 2000s as boat anchors if we have to."

A dealer in Honeywell used systems--Bill Grinker of American Used Computer--said at the meeting that the Honeywell policy had set off a "dramatic" plunge in the value of used Honeywell equipment. He said he'll produce documentation at Honeywell's midwest users group meeting Nov. 20 in Chicago.

CAMBRIDGE MEMORIES: IN ONE WAY OR ANOTHER

Undaunted by Honeywell's efforts to keep its memory storage devices off HIS systems, Cambridge Memories now is trying to gain government approval for these attachments and, therefore, inclusion in the purchase lists of the General Services Administration, the government's purchasing agency. Does that mean that users can attach Cambridge memories to Honeywell systems? Not necessarily, unless Cambridge wins a seemingly dormant year-old suit against Honeywell (July '74, p. 120). Some legal observers offer this opinion, however: If a user has or can write a contract with Honeywell that includes a "most favored nations" clause, he'll have the right to the same terms and conditions offered to other users, including the government. Ask your lawyer, they advise.

By the way, the government of Brazil liked the U.S. GSA contract enough to incorporate the requirement that foreign attachments be allowed on mainframes. Even Burroughs, which dragged its feet in negotiations with a Brazil buy, has gone along.

NOW IT'S APPEALING TO PEEL OFF THE GAG

The basic issues in the government's antitrust case against IBM haven't been joined but the side issues certainly have. While the trial crawls along at a snail's pace, IBM is now making a major issue of its attempt to remove the press gag order that it initiated in the first place. One reason, in IBM's eyes, is that the Computer Industry Assn. has engaged in "a shrill and vitriolic stream of invective against IBM." Ostensibly, IBM wants to defend itself from what it believes are attacks and criticisms in the press. The CIA believes that IBM wants the gag order removed so IBM can release "a well-orchestrated public relations, media and lobbying campaign."

HE'D RATHER FORGET THIS AUTUMN

The autumn this year just hasn't been Roger Wheeler's best season. Besides settling the IBM-Telex case (p. 123) on terms unfavorable to Telex, the Telex firm's chairman lost a bundle on a Texas cattle-fattening livestock project called Wheatheart, Inc. Wheeler and two other Telex executives lost more than \$500,000 in Wheatheart. Wheeler should cheer up, though, because things may get worse. Floyd Walker, the Telex attorney who represented Telex in the IBM-Telex case, is said to have broken with Wheeler and may be considering instituting legal action.

THE CRAY-1: WHO'LL BE THE FIRST TO USE IT?

The first model of Seymour Cray's supercomputer, the Cray-1, may not go to the ERDA's Lawrence Radiation Laboratory in Livermore, Calif., after all. Or even to the Los Alamos, N.M., site of ERDA (formerly the AEC) which also wanted the Cray-1, a 64-bit vector machine which is said to have four to five times the speed of the CDC 7600, another of Cray's designs. (Most of the first serial numbers of CDC's large machines are installed at Livermore.)

Although Cray Research still is discussing sale of the \$7.5 million system to an ERDA site, in mid-October agreement on a contract for delivery before year-end was considered "less certain" than a month earlier. Persons in Minneapolis close to the negotiations explained that Control Data Corp., which Cray left in 1972 to

LOOK AHEAD

form his own supercomputer company, wants to get in on the action with a super-computer of its own and wants a competitive procurement. Some say CDC is talking of an upgrade of the STAR computer, now installed at Livermore, which it's calling the "Super STAR."

Cray Research, which said a Cray-1 would be installed "somewhere" before next Jan. 1 (July, p. 71), now concedes that it may go to a buyer other than the ERDA, but isn't saying where.

VARIAN'S NEW MACHINE: PACKING THEM IN

Although Varian Data Machines won't begin shipping its newest minicomputer, the V 76, until early next year, it already has a \$2 million order for previous V 70 series models that incorporate the V 76's new memory configuration. Auto-Troll, a Denver company which makes interactive designing and drafting systems, has ordered 77 machines with the V 76's densely packed MOS memory design. It uses 4K RAM chips in a 16-pin configuration that allows Varian to crowd 64K words on a single circuit board and thereby pack 256,000 16-bit words within the machine's 14-inch chassis. Prices of as low as .06 cents per bit are being quoted.

A Varian official says its marketing people are "walking on water" in their excitement over the low price of the V 76 which, he says, is part of a long series of hardware and software products that will be announced next year at the rate of "two or three a month."

BUSTED BRIDGE AT BURROUGHS

Two to three years into it and with hardware design 100% complete, Burroughs Corp. has scrapped its medium scale systems group's project MS-3 which was to have been a bridge machine between the medium scale 4700 and the large scale 6700. Instead the company gave its large scale systems group the go ahead to build a bridge computer it will call the 6758. Scrapping of MS-3 will mean dismissals at Burroughs' Pasadena plant where it was being developed and some see it as heralding the closing down of this plant within the next five years. The demise of the project has been announced internally and is expected to be announced publicly for the first time at a meeting of Burroughs Users' group, CUBE, this month.

SIGN HERE PLEASE

A simple pen, linked to a computer, could prove to be the most foolproof identification for terminal access yet to be. Such a pen exists. It's going to be manufactured by Xebec Corp. as a data entry tool. Stanford Research Institute is working on a signature verification version and has a working prototype linked to a dedicated PDP-11.

No special pad is required. The pen itself is the verifier. A person to be allowed access to a system gets his signature's parameters--up to 19 of them--into the computer by writing his name three times. The system makes allowances in establishing parameters for the fact that nobody is totally consistent in his signature. Pressure is measured as is the amount of time one takes the pen up between first and last names.

A team of trained forgers at SRI hasn't been able to beat the system, even with computer-aided instruction. A crt leads the forger through each mistake. "You were too slow, you pressed too hard, etc." The forger corrects each mistake and masters the signature but, if he gets up just to stretch, he can't do it again. SRI currently is working on transmission problems involved with using the pen via telephone lines. When this is possible the pen will be tested with Tymshare Inc.'s Tymnet network.

PETTY THIEVERY--\$300,000 WORTH

There's a bank somewhere getting ripped off on a regular basis in what seems to be a computer theft but nobody seems able to do much about it. Computer crime expert Donn Parker of Stanford Research Institute was asked advice by the bank. One customer had noticed that two or three times a year there was a mistake in his statement of from 20 to 50 cents in favor of the bank. He complained. It's bank policy to simply pay on any challenge under \$2. The customer began talking to friends using the same bank. He found the same thing was happening to many of them. The bank investigated and turned up others. Some complained, some didn't bother.

If this kind of thing was happening in 300,000 accounts, said Parker, the per-

(Continued on page 148)

15,000,000 bytes plus a 32K word computer:

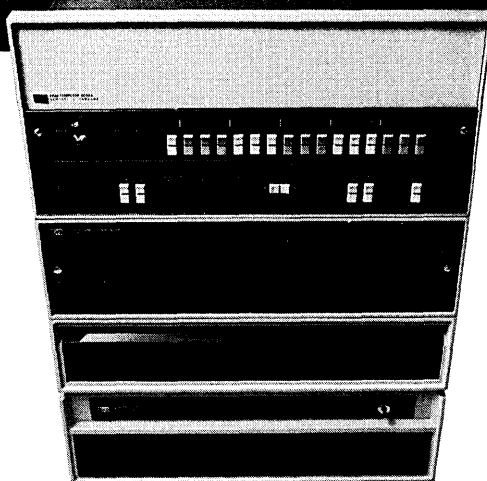

\$17,655.*

The new Hewlett-Packard MX/65 DISComputer.

• The powerful 21MX-M/20 minicomputer and the ultra fast 12962A Disc Subsystem. Now available as a plug-together team.

• No one gives you more for your money at 32K – or anywhere between 8K and 256K.

• Rugged, reliable. Engineering evaluation proves 4K RAM based 21MX minicomputer series is already 50% more reliable than our previous "core" type computers. The MX/65 package delivers rugged performance in almost every environment, permitting stable operation under extremes of temperature, motion and humidity.

• Average access time for the 12962A Disc Subsystem is a fast 25 msec. Transfer rate is 937 kilobytes per second.

• 15,000,000 byte disc storage capacity is expandable to 120,000,000 bytes.

• Because Hewlett-Packard makes its own disc drive, the MX/65 offers you a double bonus: The whole package is discountable. And, because it's a package, your integration costs are reduced.

• Optional new RTE-III operating system gives you multi-lingual, real-time, operating capability.

• Compare, then call or write for full specifications plus your free copy of our latest "Engineering Evaluation Report."

PRODUCT	32K WORDS WITH	AVERAGE ACCESS TIME	TRANSFER RATE	QTY 50 PRICE
HEWLETT-PACKARD MX/65 DISComputer	15 Mbyte disc storage Parity, EAU, and Floating Point standard	25 msec	937K bytes	\$17,655*
HEWLETT-PACKARD MX/55 DISComputer	5 Mbyte disc storage Parity, EAU, and Floating Point standard	30 msec	312K bytes	\$15,015*
PDP 11/35	5 Mbyte disc storage Parity standard, no EAU or Floating Point	50 msec	180K bytes	\$21,945*
NOVA 830	5 Mbyte disc storage Parity (not available) no EAU or Floating Point	70 msec	195K bytes	\$20,904*

225308

*Domestic USA OEM prices quantity 50.

HP DISComputers. They work for a living.

HEWLETT  PACKARD

Sales and service from 172 offices in 65 countries.
1501 Page Mill Road, Palo Alto, California 94304



Get 512 large-scale computers for the price of one.

The way to do it is to get a DECsystem-10.

Because the DECsystem-10 is a different kind of large-scale computer. It can accommodate up to 512 jobs at the same time. So all kinds of people in all kinds of places within your organization can have access to a whole lot of processing capability. Instantly. Because the DECsystem-10 gives each individual user up to 1,280K characters of directly addressable memory.

And you can use this kind of large-scale capability in lots of different ways. The DECsystem-10 can do interactive, batch, remote batch, on-line EDP,

real-time and transaction processing, and can be used for networks and hierarchical systems too.

Because the DECsystem-10 is a truly flexible big computer. It can handle from 640K to 20 million characters of memory. It offers COBOL, FORTRAN, ALGOL, APL, BASIC, and MACRO, complete with de-bugging aids. (There's even a new low-cost APL terminal.) It offers you both virtual and cache memory and an advanced Business Instruction Set. It has complete systems software — MCS, DBMS, a file management system, and our famous TOPS-10 operating system — all

supported by us, instead of you.

Best of all, the DECsystem-10 costs about half what other big systems do. And it's backed by Digital's experience with over 50,000 computer installations worldwide.

To find out how organizations like yours are using the DECsystem-10, simply call or write for our new "How I Got More Computer for Less Money" brochure.

You really can't afford not to.

Digital Equipment Corporation, Marlborough, Mass. 01752, 617-481-9511, ext. 6885.

digital

DECsystem-10.

calendar

DECEMBER

7th Nat'l. Transportation Systems Forum and Exhibit, **Dec. 2-3**, Washington, D.C. This conference, sponsored by the Transportation Data Coordinating Committee (TDCC) will attract officials from industry and government to assess the latest computer and communications technology to support electronic data interchange. Tutorial sessions and clinics are planned, and there will be displays of electronic data systems and communications equipment. Fee: \$85, including luncheons. Contact: E. A. Guilbert, TDCC, 1101 17th St., N.W., Washington, D.C. 20036, (202) 293-5514.

1975 National Conference, College and University Systems Exchange (CAUSE), **Dec. 3-5**, Denver. "Higher Education Information Systems: The Challenge of Change" is the topic for this year's conference, designed for all levels of higher education administration, including dp practitioners, users, and institutional vice-presidents. A five track format for the meeting includes presentations of management and technical concepts, both separately and combined, contributed papers, and vendor meetings. Fee: \$80, member; \$90, nonmember; add \$5 after Nov. 21. Contact: CAUSE National Office, 737 29th St., Boulder, Colo. 80303, (303) 492-7353.

Government Computer Application Conference, **Dec. 3-5**, Washington, D.C. This major government-industry conference on current government dp applications, is presented by the American Institute of Industrial Engineers. Case studies will be used to illustrate the latest advances in technology and management techniques. The status of the ADP Strategy Study prepared for General Services Administration will be covered. This event is oriented to executives and professionals in government (dp systems and procurement), and industry (systems, marketing and contracts). Fee: \$225, government and educators; \$425, industry; \$150, teams. Contact: Dept. GCAC 75, AIEE Seminars, Box 25116, Los Angeles, Calif. 90025, (213) 826-7572.

Internal Auditing State of the Art Conference, **Dec. 8-10**, Orlando. Leaders in the internal auditing profession will discuss latest practices in the field at the first meeting of its type sponsored by the Institute of Internal Auditors. Topics include working with audit committees, developing long range plans, MACRO auditing, choosing the right software package, internal audit use of minicomputers, and developing auditing standards. Fee: \$190, members; \$225, non-members. Contact: IIA, 5500 Diplomat Circle, Orlando, Fla. 32810.

Advanced Business Equipment and Materials Export Promotion, Stockholm, **Dec. 8-12**. The U.S. Dept. of Commerce will sponsor this exhibition at the U.S. Trade Center for Scandinavia. American developers and producers of advanced office systems, equipment, accessories, peripherals, supplies and materials are invited to participate. The promotion will reach the four-country Scandinavian market, which has a current annual consumption rate of more than \$300 million. Contact: Robert J. Blake, Northern Europe Div., U.S. Dept. of Commerce, Washington, D.C. 20230, (202) 967-3088.

Annual Conference, California Educational Data Processing Assn. and California Educational Computing Consortium, **Dec. 11-12**, Los Angeles. More than 50 sessions of interest to teachers, faculty, staff and administrators of all educational levels will cover computer assisted instruction, modeling and simulation, computer science, management information systems, and privacy, among other topics. More than 60 exhibits are planned; luncheons, included in the fee, will feature major speakers. Fee: \$40, two days; \$28, one day; add \$5 after Dec. 6; \$4, students. Contact: Ellen Landers, CECC/CEDPA Trade Show, 17123 Chatsworth St., #10, Granada Hills, Calif. 91344, (213) 360-2786.

MARCH

Data Communications INTERFACE '76, **March 29-31, 1976**, Miami Beach. DATAMATION is cosponsor of the fourth annual presentation of the original data communications conference and exposition. INTERFACE '76 will have more than 50 seminars and sessions with over 100 speakers. A committee representing data communications users and suppliers, as well as consultants from industry and education, are preparing the program details. Contact: Matt Smith, 160 Speen St., Framingham, Mass. 01701, (617) 879-4502.

CALL FOR PAPERS

COMPUTER '76 Spring, **Feb. 24-26, 1976**, San Francisco. A "short notes" session will be featured at the IEEE Computer Society's 12th international conference. Presentations are limited to five minutes. Submit 200-300 word summary, together with name and affiliation, to Prof. Martin Graham, Electrical Engrg. and Computer Sciences Dept., Univ. of California, Berkeley, Calif. 94720. Deadline is Jan. 1, 1976.

7th Annual Modeling and Simulation Conference, **April 26-27**, Pittsburgh. Special emphasis for the conference will include energy, social, economic, and global modeling and simulation. Papers on these and all traditional areas of modeling and simulation are invited. Two copies of titles, authors, authors' addresses, abstracts (50 words) and summaries should be submitted by Jan. 30, 1976 to William G. Vogt, Modeling and Simulation Conference, 231 Benedum Engrg. Hall, Univ. of Pittsburgh, Pittsburgh, Pa. 15261.

6th Annual ACM Symposium, "Theory of Computing," **May 3-5, 1976**, Hershey, Pa. Papers describing original research into the formal analysis of computing problems are being sought by the Association for Computing Machinery, special interest group for automata and computability. Typical subject areas are analysis of algorithms, formal semantics of programming languages, theoretical studies of computer systems, and theory of computation. Send seven copies of detailed abstracts by Dec. 1 to Dr. Ashok K. Chandra, T. J. Watson Research Ctr., P.O. Box 218, Yorktown Heights, New York, N.Y. 10598 *

Conferences are generally listed only once. Please check recent issues of DATAMATION for additional meetings scheduled during these months.



They did more of your work today, so you can do more tonight.

The new MDS System 2300 lets the people who create your workload handle some of the load.

System 2300 is an intelligent programmable terminal which gives you the efficiency of document preparation and *simultaneous data entry*, where the data originates.

Your programmed instructions are displayed in plain English on the 2300 CRT and guide the operator through forms preparation. The result is properly prepared data waiting for automatic transmission to your central processor. Data and forms are prepared in a *single, error-free operation* on System 2300 by your existing clerical personnel.

At night the 2300, in unattended mode, sends selected disk stored data to your Network Controller or CPU. And processed results are delivered to your terminals overnight. System 2300 can satisfy your local, central and network objectives. It can do it faster, more accurately and with greater flexibility than any previously available system. With intelligent data entry and document preparation handled remotely

during the day, you reduce the processing load on your computer center.

Currently installed 2300's are demonstrating remarkable productivity gains in applications such as invoicing, purchasing, order entry, inventory control and management reporting.*

System 2300 comes from the Data Entry specialists, and is backed by one of the finest support teams in the industry. With System 2300 you can consolidate your data management resources, increase operating efficiency, reduce central computer usage, and make a significant contribution to your bottom line. By stretching your 8-hour day into 24 hours of productivity.

Ask your local MDS representative to show you how System 2300 can reduce your workload so you can do more work. Call (201) 540-9080 or write Mohawk Data Sciences Corporation, 1599 Littleton Road, Parsippany, NJ 07054. We'll get back to you overnight.

*Documentation available on request

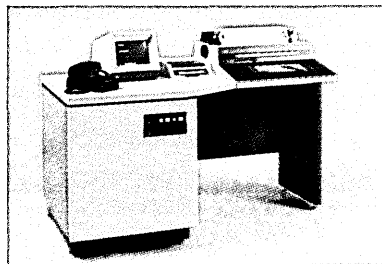

MDS[®]

Mohawk Data Sciences

© Copyright 1975 by Mohawk Data Sciences Corporation

CIRCLE 27 ON READER CARD

Meet the new 990 Computer Family from Texas Instruments

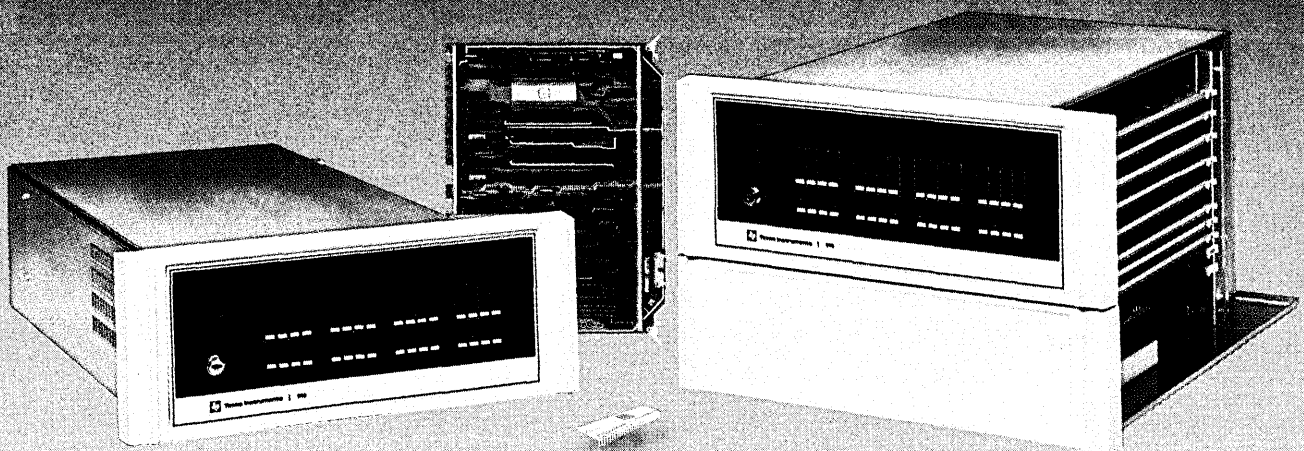

**Introducing the 9900 Microprocessor
and 990 Series Micro/Minicomputers**

Upward Compatible Software and Downward Competitive Prices

At TI, we've started a new family tradition in micro/minicomputers with the 990 computer family . . . a new tradition based upon a heritage of semiconductor leadership.

The 990 computer family sets new price/performance standards because of an important milestone in MOS technology . . .

The TMS 9900 single-chip, 16-bit microprocessor.

Powerful enough to be the heart of a full minicomputer, the TMS 9900 is also the best microprocessor going for terminals, machine monitoring and control, and a host of OEM applications.

All in the Family

The same company . . . Texas Instruments . . . makes every member of the family, and makes every member software compatible, from the bottom up. The new Model 990/4 microcomputer and Model 990/10 minicomputer use the instruction set of the TMS 9900 microprocessor. This means that software developed for the low-end computers will be compatible with the higher performance models. And, users can expand their systems with a minimum of interface and software adaptation.

The TMS 9900 Microprocessor

The TMS 9900 is a 16-bit, single-chip microprocessor using MOS N-channel silicon-gate technology. Its unique architecture permits data manipulation not easily achievable in earlier devices. With its repertoire of versatile instructions and high-speed interrupt capability, the TMS 9900 microprocessor provides computing power expected from a 16-bit TTL computer.

The Model 990/4 Microcomputer

It's a complete computer on a single printed circuit board using the TMS 9900 as its central

processor. The 990/4 is ideally suited for terminal control, peripheral device interface control, and as a CPU for OEM customers.

In addition to the TMS 9900 microprocessor, the 990/4 microcomputer contains up to 8K bytes of dynamic RAM, up to 2K bytes of static RAM and/or PROM, eight vectored interrupts, front panel interface, real-time clock input, two I/O buses for low- and high-speed devices, and optional ROM utilities.

With the 990/4, you can select a low-cost OEM package, a 7-inch or 12¼-inch rack-mountable chassis, or a table-top enclosure . . . and memory expansion to 58K bytes.

Price: The Model 990/4 microcomputer with 512 bytes of memory is only \$368 without chassis and power supply. This same model with 8K bytes of memory is only \$512*.*

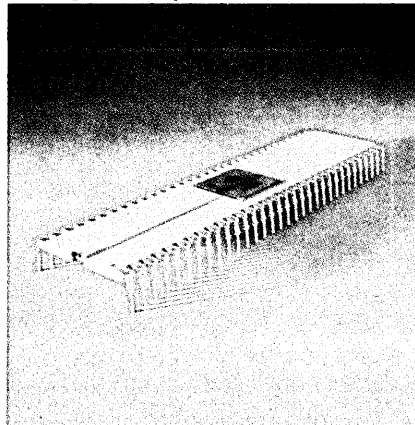

State-of-the-art TMS[®] 9900 microprocessor . . . 16-bit, single-chip CPU with minicomputer instruction power.

The Model 990/10 Minicomputer

The most powerful member of the family is the Model 990/10 general-purpose minicomputer. The 990/10, a TTL implementation of the 990 architecture, provides the high-performance speeds demanded in many applications.

A memory mapping feature providing memory protection and privileged instructions supports memory expansion to two million bytes. And TILINE**, an asynchronous high-speed I/O bus, supports both high-speed and low-speed devices. Chassis options are the same as those for the 990/4.

Price: With 16K bytes of memory, chassis, power supply and programmer's panel, the Model 990/10 minicomputer is only \$1968.*

Built Better Backed Better

In addition to the family of compatible hardware, Texas Instruments backs you with complete software and support. **Standard software packages include memory-resident and disc-based operating systems; FORTRAN, COBOL, and BASIC compilers; and program development packages with utilities.** And, for you to develop application programs for the 990/9900 family, we offer **cross support on timesharing networks** and standalone software development systems. One is a low-cost system using the 990/4 . . . the other is a disc-based system using the 990/10. And, a **prototyping system** is offered for TMS 9900 users to develop custom software and firmware modules.

TI supports you with training and applications assistance, plus an installed nationwide service network backed by TI-CARE†, our automated remote diagnostic, service dispatching, and real-time field service management information system.

Get to know our new family. Call your nearest TI office, or write Texas Instruments Incorporated, P. O. Box 1444, M/S 784, Houston, Texas 77001. Or, phone Computer Equipment Marketing at (512) 258-5121.



Arlington, Va. (703) 527-2800 • Atlanta, Ga. (404) 458-7791 • Boston, Ma. (617) 890-7400 • Chicago, Il. (312) 671-0300 • Clark, N.J. (201) 574-9800 • Cleveland, Oh. (216) 464-2990 • Costa Mesa, Ca. (714) 540-7311 • Dallas, Tx. (214) 238-5318 • Dayton, Oh. (513) 253-6128 • Denver, Co. (303) 751-1780 • Detroit, Mi. (313) 353-0830 • El Segundo, Ca. (213) 973-2571 • Hamden, Ct. (203) 281-0074 • Houston, Tx. (713) 494-5115 • Indianapolis, In. (317) 248-8555 • Milwaukee, Wi. (414) 475-1690 • Minneapolis, Mn. (612) 835-5711 • Philadelphia, Pa. (215) 643-6450 • Rochester, N.Y. (716) 461-1800 • San Francisco, Ca. (415) 392-0229 • Seattle, Wa. (206) 455-1711 • St. Louis, Mo. (314) 993-4546 • Sunnyvale, Ca. (408) 732-1840 • Winter Park, Fl. (305) 644-3535 • Amstelveen, Holland 020-456256 • Bedford, England 58701 • Beirut, Lebanon 452010 • Cheshire, England 061 442 8448 • Copenhagen, Denmark (01) 917400 • Croydon, England 01-686-0061 • Essen, Germany 01241/20916 • Frankfurt, Germany 0611/39 90 61 • Freising, Germany 08161/801 • Milan, Italy 6888051 • Montreal, Canada (313) 353-0830 • Nice, France (93) 20-0101 • Paris, France (1) 630-2343 • Slough, England 33411 • Stockholm, Sweden 62 71 59/62 71 65 • Sydney, Australia 831-2555 • Tokyo, Japan (3) 402-6181 • Toronto, Canada (313) 353-0830

TEXAS INSTRUMENTS
INCORPORATED

*OEM quantity 50, U.S. domestic prices.

** Trademark of Texas Instruments.
† Service Mark of Texas Instruments.

BEFORE YOU NIBBLE AT THEIRS, GET THE WORD ON OURS.

You've read recently of a price reduction and a new rental/purchase plan for the 3270 display terminal. Consider them well.

Then consider this.

Raytheon's PTS-100 terminal is still ahead by a lot of carrots:

- it still costs you less money than the price-reduced 3270
- it can be provided with extended-term lease plans — to maximize your savings
- it's available with high-speed character and line printers and card readers
- it controls local printing — no okay is needed from the host computer
- the PTS-100 has local format storage
- it's intelligent — you can design your own application and modify it easily.

Before you nibble at those 3270 carrots, taste ours. Write Raytheon Data Systems, Marketing Dept., 1415 Boston-Providence Turnpike, Norwood, Massachusetts 02062 — or call 800-225-9874 (toll-free).

When you build better information processing systems ... **the Word gets around.**

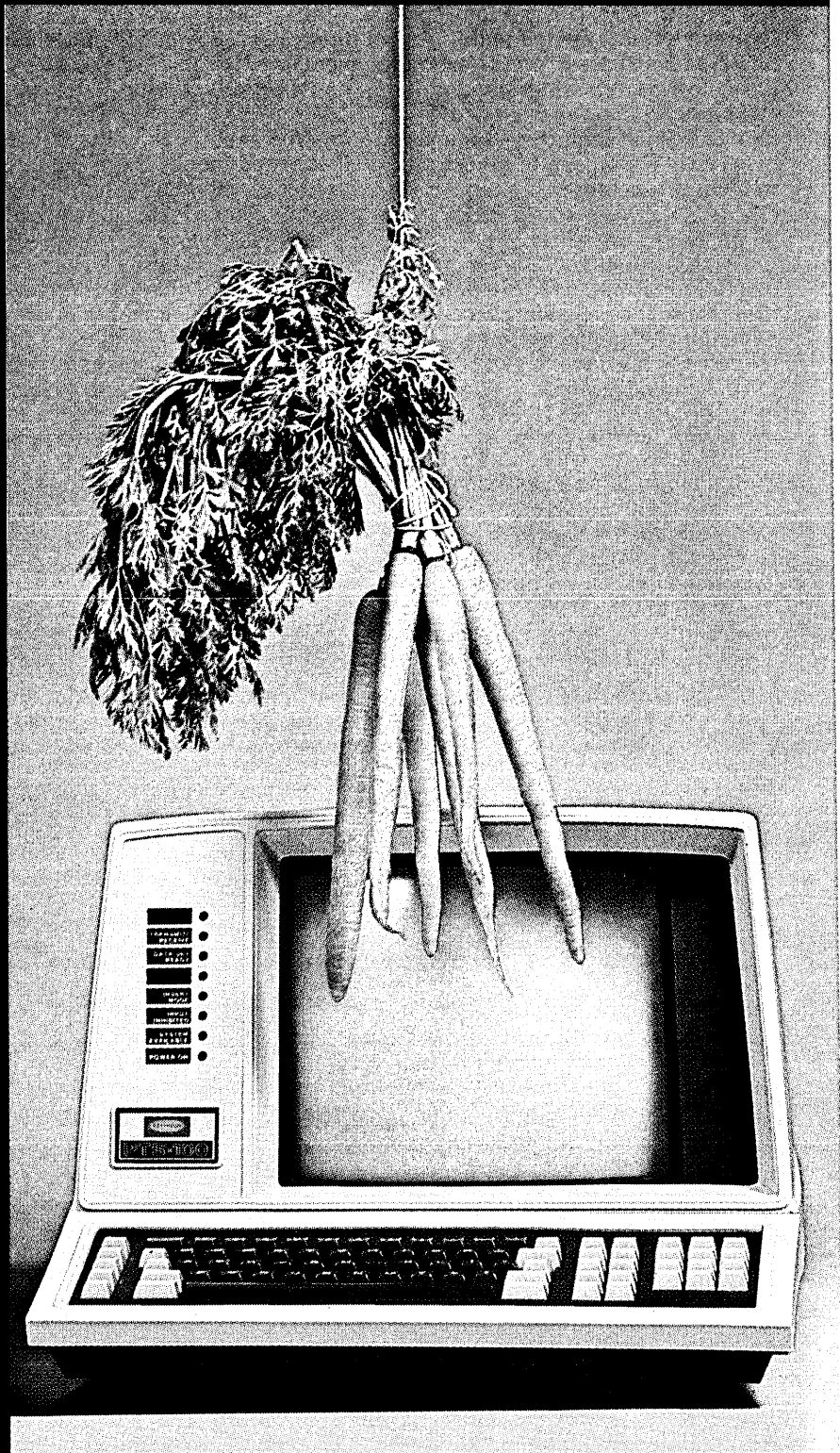

INTELLIGENT TERMINALS, MINICOMPUTERS AND TELECOMMUNICATIONS SYSTEMS

RAYTHEON DATA SYSTEMS



CIRCLE 62 ON READER CARD

source data

SOURCE DATA provides information on books, courses, references, reports, periodicals, and vendor publications.

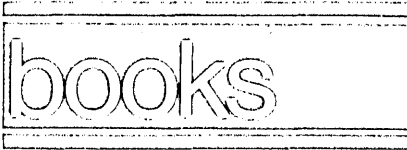

The U. S. Computer Industry: A Study of Market Power

By Gerald W. Brock
Ballinger Publishing Co., c/o J. B. Lippincott Co., E. Washington Sq., Philadelphia, Pa. 19105 (1975)
252 pp. \$15

This interesting, useful book is an economic analysis of the computer industry, pointed toward evaluating the merits of the existing IBM-dominated structure and supporting the author's views of actions that should be taken.

To this reviewer, the best aspect of the book is its excellent summary history of the events that have shaped the industry's structure: technological innovations, entries and exits of competitors, major legal actions, antitrust suits, the role of the Federal Government, and IBM's product and market actions. The histories are succinct and complete; minor omissions and errors exist but don't matter.

The history of IBM's actions is derived in considerable part from the Telex papers; the author has studied them thoroughly and has used excerpts fairly and intelligently. "Computers" and "peripheral equipment" are nowhere defined carefully, however. This lack makes it easy to disagree with the author's generalizations, and hard to agree with his broad conclusion about desirable actions.

At several points in the book, efforts are made to develop quantitative models of optimum competitive behavior in the computer industry, particularly all of Chapter 6, entitled "An Optimal Price Model for the Computer Industry." These efforts are rather unsuccessful for several reasons. Computers are treated as distinct entities rather than as components in evolving networks. Technological change is treated as a continuous variable rather than as a phenomenon of breakthroughs and generations, and its effect is assumed to be only changes in price/performance rather than in the basic functional nature of systems.

Most important, system software is not recognized as the dominant product of the computer industry and the primary determinant of user acquisi-

tion decisions. It is noted as important, but user purchase decisions are everywhere assumed to be dominated by the price and instruction execution speed of computers. Some of IBM's competitors wish this were true!

Lacking is any model of a computer manufacturer's internal cost and profit considerations. The author acknowledges that he has no inside information and these are not public knowledge. However, they are widely known and an adequate model could have been developed through interviews with computer manufacturers.

The author's analysis of the past antitrust suits and the applicability of existing law is excellent and thoughtful. For example, at the conclusion of his summary of private antitrust actions he says: "The negative side of the antitrust cases is the heavy use of resources for legal battles with no apparent social gain. . . . The number of cases filed indicates the need for a clear final decision from a high court about the legality of current structure and conduct in the computer industry in order to protect both IBM and its competitors from wasteful legal battles." Right on!

The author shows that the Sherman Act simply doesn't apply to the issue of the computer industry's structure, and offers the opinion that the Industrial Reorganization Act introduced by Senator Hart would be more suitable. Maybe, but the act assumes that "extensive studies" would always determine the "right" competitive structure for an industry. The author himself scores government regulation of industries as generally pernicious in its effect; is there any basic difference?

The author believes IBM should be restructured (not regulated), partly on the basis that "the rate of technological progress could be even higher if it were not for the disincentives to innovation that result from IBM's dominance." This reviewer disagrees strongly, believing that technological progress has proceeded at the fastest rate that users were able to accept, and that permitted a few of the competitors to recover their investments in rented machines.

The author's proposal is to break IBM's data processing activities into a maintenance company, a peripheral equipment company, a marketing company, and a cpu company which would handle system software. There's the rub: who would handle IMS, VTAM, VSAM, NCP, and the other vital inter-

face software products? Who would provide the competent single point of responsibility that the customers insist upon and that accounts for much of IBM's success?

The author does not come to grips with the issue of IBM's \$3.8 billion in cash, either. He proposes that each manufacturing division would finance the rentals of its products, presumably with the full corporate resources at its disposal. Some analysts think this alone would assure perpetuation of IBM's dominance, and that any restructuring would be moot.

These criticisms are not to imply any lack of merit in the book: in fact, if any book addressed to this heated and complex subject were noncontroversial, it would probably be uselessly bland. The book is of value to any student of the computer industry, if only for its succinct and fair-minded retrospective material.

—Frederic G. Withington

Mr. Withington is a senior staff member of Arthur D. Little and a contributing editor of DATAMATION.

An Introduction to General Systems Thinking

by Gerald M. Weinberg
Wiley & Sons, Inc., 1975
279 pp. \$16.95

Gerald Weinberg's book is a gold mine. Its approach is on *how* to think about things rather than on *what* to think. Anyone who believes Weinberg's definition of a system will be enriched by reading the book: "What is a system? As any poet knows, a *system is a way of looking at the world.*"

To Weinberg, "systems thinking" is the way people learn to create order out of the chaos around them. Two alternative approaches to systems thinking are "general systems thinking" and the disciplinary method. Weinberg contrasts these two approaches throughout his book. Under the disciplinary method, he maintains, a specialist builds a foundation of detail within a specific discipline and looks at the world with a perspective based on that foundation. For example, physicists look at the world through the point of view of physics. Salesmen, engineers, accountants, chemists, etc. have their own perspectives.

"General systems thinking," on the other hand, is an approach which identifies general "laws" and "principles" which can be applied to bring any situation into focus. According to Weinberg, these laws and principles are generalizations of laws and principles we normally find applicable to specific disciplines such as physics, economics, psychology, or mathematics. He maintains, however, that most of these specific laws and principles can be gener-

source data

alized and thus made useful in the study of any discipline. For example, we typically identify the laws of thermodynamics with the study of physics. Weinberg maintains that a "generalized thermodynamic law" can be applied to any system, not just to physical systems. The same is true, he says, for other laws such as the "law of diminishing returns," which we normally identify with economics.

Most of Weinberg's book is spent exploring various disciplines and extracting concepts of general use from them. The result of his efforts is a work which is easy and fun to read, while at the same time profound in its implications for managers, scholars, students, systems analysts, scientists, and anyone else who may think he already knows everything there is to know.

—Dan Appleton

Mr. Appleton is director of management information systems for the Byron Jackson Div. of Borg-Warner Corp. He has been in systems design and development for 10 years for the Dept. of Defense and Westinghouse Air Brake among others.

BOOK BRIEFS . . .

So You're Going to Automate
by Jack Munyan
Petrocelli/Charter, 1975
160 pp. \$10

Once the decision to automate accounting systems has been made, the road to conversion is not necessarily a smooth one, and hence this "edp guide to automation for small businesses." Using a practical approach, the book identifies problems that can arise, discusses selection of the appropriate system, and offers solutions to some of the pitfalls found during the transition process. Guidelines are presented for automating the following accounting applications: accounts receivable, accounts payable, payroll, cost center analysis, inventory control, and general ledger.

Computer Programming Handbook
by Peter A. Stark
Tab Books, Blue Ridge Summit, Pa.
17214 (1975)
518 pp. \$12.95 (\$8.95 paperback)

This is a comprehensive handbook covering such subjects as history of computing, types of equipment, flow-charting, debugging, use of subroutines and utility routines, and more. The three types of computer languages—machine, symbolic, and problem-oriented—are extensively treated; the problem-oriented language section concentrates on FORTRAN IV. Worked examples of sample problems, including computer printout, are given. Con-

stants and numbers tables appear in an appendix. Although mathematics for computer applications is also covered, knowledge of higher mathematics is not required. In all this seems to be a useful book for the programmer to have at hand; however, narrow margins may mar the ease of reading.

Data Base Description (Proceedings of IFIP Special Working Conference, January 1975, Belgium)
B.C.M. Douque and G. M. Nijssen, eds.
American Elsevier Publ. Co., Inc.,
52 Vanderbilt Ave., New York, 1975
382 pp. \$31.75

The main theme of this conference, attended by representatives of 12 countries, was a technical evaluation of CODASYL Data Description Language. The papers presented analyzed the DDL's strengths, proposed improvements, and forecast the trend for the future. Included in the proceedings are summaries of the panel discussions which took place following some of the papers, and recommendations which resulted.

APL: The Language and Its Usage
by Raymond P. Polivka and
Sandra Pakin
Prentice-Hall, Inc. 1975
579 pp. \$17.95

With the increased application of APL to commercial and industrial areas, as well as its continued use in education and research, this is a timely publication. Chapters are devoted to basic APL, function definition, the shape of data, elementary functions, array handling capabilities, data selection and rearrangement, communications with the APL.SV supporting system, and APL.SV data communications. The well-illustrated book seems to be carefully organized, and contains numerous problems and examples.

ICCC-74 Proceedings (Stockholm Aug. 12-14, 1974)
ICCC, P.O. Box 9745, Wash., D.C.
20016 (1975)
610 pp. \$30

The second International Conference on Computer Communication (ICCC) contains a large number of papers and presentations by international participants on progress in computer communication and applications in data transmission. Areas covered include packet switching, human behavior and education applications, network performance and economics, distributed intelligence, circuit switching, transmission and multiplexing, social impact, man-machine interaction, international services, etc.

Effective Use of ANS COBOL Computer Programming Language
by Laurence S. Cohn
Wiley & Sons, 1975
178 pp. \$10.95 (paperback)

This text, primarily geared to the programmer working with IBM's OS or DOS

systems, requires an understanding or concurrent study of COBOL. The material includes sections on file organization, storage handling, debugging methods, and programming techniques. A substantial number of illustrations demonstrates various approaches and recommendations.

Computer Communications
Paul E. Green, Jr. & Robert W. Lucky,
eds.
IEEE Press, 345 E. 47 St.,
New York, N.Y. 10017 (1975)
616 pp. \$17.95 (\$13.45 for
IEEE members)

This collection of 60 articles reprinted from journals and magazines such as DATAMATION should bring the reader up-to-date on the subject. The book is divided into four parts: the Computer Communications Environment (which includes papers on regulatory and economic factors, security, and reliability); System Elements (with sections on terminals, modems, line control, error control, multiplexors and concentrators, communication software, and communication processors); Digital Transmission Media (including sections on AT&T facilities, other U.S. facilities, data communications worldwide, and new media for transmission); and Total Systems (with sections on teleprocessing networks, computer networks, loop systems, and system modeling and analysis). Each of the sections within the four parts begins with a brief tutorial, which includes references to other works.



All About Minicomputers
Detailed specifications of 189 minicomputers and an analysis of users' experience with 2,182 minicomputers are provided in the 54-page reports, *All About Minicomputers*. This reprint from the September supplement to *Datapro 70* features comparison charts of data formats, processing facilities, peripheral equipment, software, pricing, and availability. Price: \$10. DATAPRO RESEARCH CORP., 1805 Underwood Blvd., Delran, N.J. 08075.

Structured Programming in COBOL
Fourteen papers are included in the 280-page proceedings of the CODASYL "Symposium on Structured Programming in COBOL—Future and Present," held on April 7, 1975 in Los Angeles. Price: \$15 (\$10 to ACM members). THE ASSOCIATION FOR COMPUTING MACHINERY, 1133 Ave. of the Americas, New York, N.Y. 10036.

Introducing the revolutionary
 new Interrogator 880™
 Security System that controls,
 monitors, and documents
 the movement of people
 and vehicles through
 specific points from
 one central location...
 to anywhere in the world.

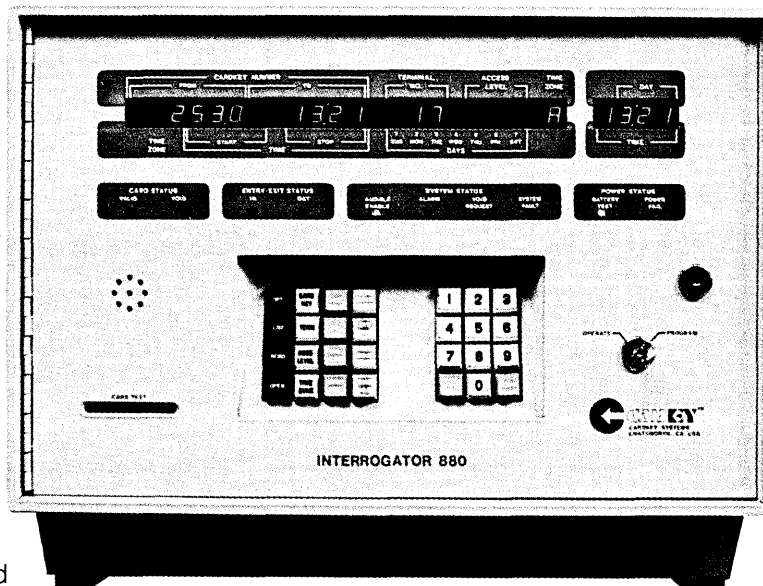

There is no other security system currently being produced with the performance capabilities of the Interrogator 880.

The Interrogator 880 is a dedicated mini-computer, programmed to control, monitor and command from a central location to and from as many central points on or off the premises as needed. You may retrieve, through hard copy reports, magnetic tapes, or route data through interfacing equipment direct to a main frame computer. The system may begin with a simple installation and thereafter be field-expanded to meet your growing requirements.

Once a Cardkey Securiti-Card™ is issued, it need never be retrieved. All commands and controls are programmed through the 880, which issues any changes in levels of security. The Interrogator 880 completely controls and

monitors entry/exit at all card reader terminal locations by permitting or denying access. It will record both valid and invalid entry attempts and even report reasons for denying access. It can also control elevators, doors,

CARDKEY

CARDKEY SYSTEMS

A DIVISION OF GREER HYDRAULICS, INC.

20339 NORDHOFF STREET

CHATSWORTH, CALIFORNIA 91311

(213) 882-8111/TELEX 651-375

European Manufacturing and Sales Office:

43/45 Milford Road, Reading, Berks RG1 8LG, England
 Telephone: 0734 582804 TELEX: 847733

parking gates, as well as monitor alarms and any environmental conditions such as fire, flood, temperature, pressure and noise levels.

Since its recent introduction, the Interrogator 880 already has been field-proven by utility

companies, government agencies, institutions, high rise buildings, data-processing centers, financial organizations, the petroleum industry and many manufacturing firms.

Because the Interrogator 880's applications are so diverse, we've only mentioned a few. Its application capabilities are limited only by your own imagination. No matter what your own perplexing problems—in the area of security—the 880 can handle them.

Call or write for a free security analysis. Or simply ask for additional technical information.

THE NEW SYCOR 440



Clustered data entry and concurrent processing with shared files...\$677 a month.

The Sycor 440 System: the newest addition to our family of compatible intelligent terminals.

Our new distributed processing system lets you perform data entry and inquiry/response concurrent with background processing. So you don't need multiple systems to do multiple jobs. At \$677 a month (for four keyboards, communications, cassette, and a five mb disk on a three year lease, with maintenance) you can perform all these functions—plus many more you never thought possible at such a low price.

Intelligent data entry.

You can save time and money by catching operator errors as they happen, prior to transmission to the central computer site. And reduced errors mean greater operator productivity, lower communication costs and reduced mainframe processing.

Field editing. As soon as you get the system, you can implement our basic data entry package. Without any fancy programming.

TAL II. To extend the 440's power, use our new data entry language, TAL II. This easy-to-use, high-level language lets you customize data entry programs. Instructions are also provided for arithmetic operations, conditional data entry, range checking, table look-up, equal/compare and a host of other intelligent features.

Shared file access.

The 440 system lets you share and access files locally, reducing investments in telephone communications and central CPU resources.

Data entry made easy. Now

each operator, at her own display, can make use of current data in shared files to support data entry functions. For reduced keystrokes and lower error rates.

Inquiry/Response. File look-up is made simple with up-to-date information on-site, using the 440's own file management and disk storage capabilities.

System modularity.

Design your own system with a variety of options and peripherals.

Supports from 1 to 8 displays.

Each is controlled by the Sycor processor and is capable of performing tasks independent of other displays.

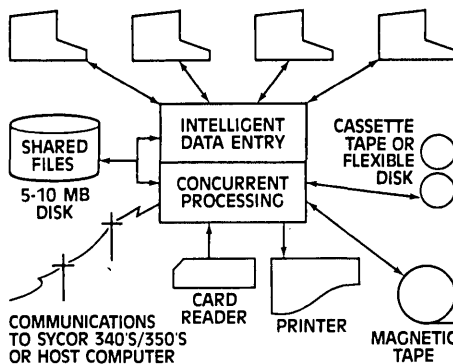

Choice of 5 and 10mb disks.

Store and retrieve programs, shared files, and data at remote locations.

Wide variety of peripherals.

And to complete our system configuration, choose from matrix and line printers, computer-compatible tape drives, card readers, and a variety of communications options.

Compatibility.

There's full software compatibility with our Model 340 and 350 stand-alone terminals. Keyboards are also compatible.

Programming. One program fits three different systems—340, 350 and 440.

Communications. Communicate with the mainframe, emulating IBM 2770, 2780 or 3780 protocols. Or use the 440 as a polling station at your central computer site to receive and transmit data to remote 340s, 350s, and 440s.

Concurrent processing.

And best of all, while data entry is being performed in the foreground, you can be doing other jobs concurrently in the background. Jobs that can save you time and money. Jobs like:

Remote job entry. Use the 440 with its card reader and 300 LPM printer for large-scale remote job entry. And since the system contains a CRT and a keyboard, you don't pay extra for them.

Multi-terminal printer support. Each display can interleave print data to one printer as the data is being entered. So, you don't need a separate printer for each display.

Report generation. Sycor-provided programs let you produce all sorts of management reports—sales analysis, inventory, or billing—at the same time as you are performing data entry.

File maintenance. And the Sycor 440 allows you to do editing, sorting, updating, and file transfer in a background operation.

The lowest-priced distributed processing system.

When you consider all the advantages of our 440 system, and then consider its low monthly cost, we think you'll agree: it's the best system in the industry.

For more information on the new Sycor 440, or any of our other intelligent terminal systems, contact your Sycor representative, or write our corporate offices.

SYCOR

...applying intelligence to remote processing.

CORPORATE OFFICES: Ann Arbor, Michigan 48104 (313) 971-0900. DISTRICT SALES OFFICES: Atlanta (404) 455-3070 • Boston (617) 890-7290 • Chicago (312) 297-5200 • Cleveland (216) 741-4840 • Columbus (614) 888-8657 • Dallas (214) 521-6710 • Denver (303) 458-0794 • Detroit (313) 355-5770 • Greensboro, N.C. (919) 274-2964 • Hartford (203) 529-1100 • Houston (713) 785-2953 • Indianapolis (317) 788-1577 • Kansas City, Mo. (816) 842-7799 • Los Angeles (213) 640-0120 • Miami (305) 592-1533 • Milwaukee (414) 257-3780 • Minneapolis (612) 854-2309 • Newark (201) 773-7400 • New York (212) 371-9050 • Philadelphia (609) 665-1170 • Pittsburgh (412) 922-3350 • Portland, Ore. (503) 227-5672 • San Francisco (415) 349-6626 • St. Louis (314) 878-0090 • Washington (703) 527-0200. CANADA: Sycor International Ltd.; Ontario and Quebec.

source data

Programming Management

Aimed at giving "instant access to every answer you need to organize, administer, and manage a modern programming department," the *Auerbach Computer Programming Management* is a service providing portfolios on specific problems the programming manager faces. "Estimating Costs to Program," "Desk-Checking Techniques that Save Debugging Time," "Factors and Considerations in Selecting the File Organization," "Guidelines for Programming Standards," and "Pro-

gramming Technique to Improve Reliability of the Total Information System" are some of the 40 titles included in the one-volume, loose-leaf format. Additional portfolios are sent every other month. Subscription: \$125/yr. AUERBACH PUBLISHERS INC., 121 N. Broad St., Philadelphia, Pa. 19107.

Software Packages

User purchases of software packages and packaged services in 1974 were up 73% over 1973, and about 70% of these packages were used without modification. The most popular packages were in banking, data base management, report program generators, pay-

roll, and premium accounting. As time and work savers, packages seem to be satisfying more users, according to a survey of 221 users reported in *The Computer Software Packages and Packaged Computer Services Market*. The 193-page report evaluates 110 specific packages and services, details user preferences, and analyzes current trends. Price: \$575. FROST & SULLIVAN, INC., New York, N.Y.

FOR DATA CIRCLE 200 ON READER CARD

EFT Handbook

As part of ABA's EFT strategy study, Arthur D. Little, Inc. has compiled *The Bankers' EFT Handbook* "to help bankers better understand the concepts and far reaching effects of electronic funds transfer and to clarify some of the issues raised by the spread of EFT through the banking industry," according to an ABA spokesman. EFT developments policy issues, and future trends are among the subjects covered. Price: \$20 (\$10 for ABA members). AMERICAN BANKERS ASSN., 1120 Conn. Ave., N. W., Washington, D.C. 20036.

Minicomputers

A new Theme/Pak series is launched with *Minicomputers*, a compilation of abstracts, digests, and reviews on the topic which have appeared since 1969 in *Data Processing Digest*. Comprised of 80 items, the loose-leaf volume presents in one convenient place the up-to-date results of current knowledge and research in the minicomputer field. (The next Theme/Pak scheduled is *Structured Programming*.) Price: \$75. DATA PROCESSING DIGEST, INC., 6820 La Tijera Blvd., Los Angeles, Ca. 90045.

Telecommunications Planning

Common carrier rates, traffic tables for automatic and manual switching systems, data modem interface standards, and other reference tables are contained in the monthly updated, loose-leaf format *Executive Telecommunication Planning Guide*. The 350+ page manual also features a glossary, a subject cross-reference index, intrastate WATS tables, and World Numbering Plan directory. Annual subscription: \$175 plus postage (\$20 No. America, \$50 overseas). CENTER FOR COMMUNICATIONS MANAGEMENT, INC., P.O. Box 324, Ramsey, N.J. 07446.

Data Architecture Charting

In an effort to apply a production technique or tool to the programming process, CAP has come up with a reference manual (94 pp.) outlining the data architecture charting method which is a level or two above flow-

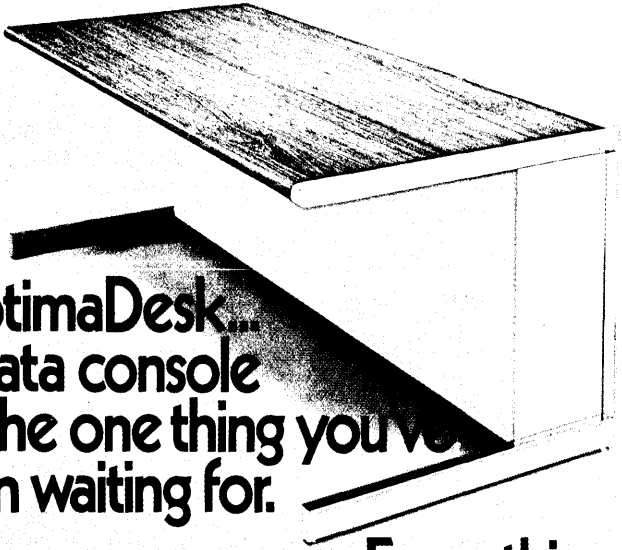

**OptimaDesk...
the data console
with the one thing you've
been waiting for.**

Everything.

Every feature you'll ever conceivably want, including the ones that cost extra in other data consoles (rolled front edge, chrome legs and the like.) Every color, from Burnt Orange to Sky Blue to Black; fourteen standard colors in all. Standard widths are 24", 45" and 66", each in a choice of keyboard or desk heights. And the two styles you see here are just the beginning.

Above all, the OptimaDesk is the finest quality furniture ever built for electronic instruments. And the price is right. The 45" model is around \$239, for instance.

Write to us for complete information.

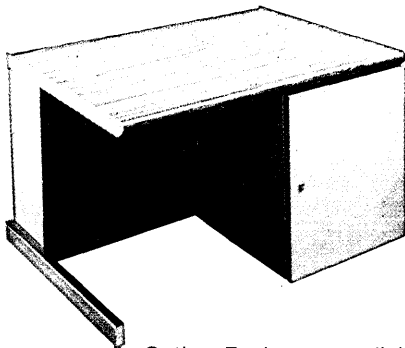

OPTIMA®

Optima Enclosures, a division of Scientific-Atlanta, Inc. 2166 Mountain Industrial Blvd., Tucker, Georgia 30084 or call (404) 939-6340
CIRCLE 91 ON READER CARD



When your computer speaks, Bell & Howell's COM understands.

If you've been hesitant about getting into COM because of the alterations it would require, Bell & Howell has some reassuring news for you.

Our COM recorder is compatible with most computers now in use. It speaks virtually any computer language. Job setup is accomplished through the use of a single job control card. So human error is substantially reduced.

And when it comes to COM retrieval, we have an unusually broad range of COM compatible readers and reader/printers.

In short, Bell & Howell's

entire COM program, from hardware to software to support functions, are focused on *your* way of doing business... not ours.

And a Bell & Howell COM system speaks your language in still another way; it costs a lot less than you might think. To get the word, write: Bell & Howell COM Products Division, 1451 Quail Street, Newport Beach, California 92660. Or call Pat Flynn, collect, (714) 752-1940.

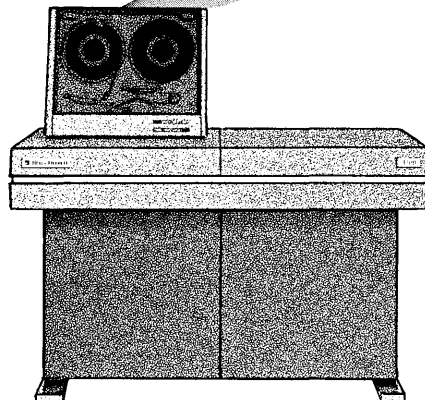

BUSINESS EQUIPMENT GROUP

 **BELL & HOWELL**

©1975 BELL & HOWELL COMPANY
All Rights Reserved.

source data

charting in giving an overview of a system. Instead of describing table formats, file structure, and control block relationships, this method presents a diagramming technique to show data relationships that will purportedly be to the software designer what the blueprint is to the draftsman. Chapters cover representing sets, relationships between sets, and structures. Price: \$10. COMPUTER ANALYSTS AND PROGRAMMERS LTD., CAP House, 14-15 Great James St., London, England WC1N 3DY.

Managers and Computers

A 40-page brochure, *The Executive and Today's Business Systems*, introduces the manager to the use of computers and modern business systems. Written by a business consultant in a clear style, the brochure attempts to show the executive the alternatives in decisions to use computers in the business environment. Free to persons requesting it on company letterhead. J. A. ROCKWELL & ASSOCIATES, 3625 N. 16th St., Phoenix, Ariz. 85016.



Microcomputer Kits

Microcomputers have opened up a new hobby for dp people, do-it-yourself computer construction. Although the "Cramerkits" introduced in these specification sheets are intended for use by serious designers, hobbyists take note too. Six kits are described, for microprocessors from Intel, Motorola, Texas Instruments, Mostek, AMD, and RCA. CRAMER ELECTRONICS, Newton, Mass.

FOR COPY CIRCLE 201 ON READER CARD

Nova and DEC Discs

Separate specification sheets describe the sys-10 head-per-track discs for Data General Nova minicomputers (models 2, 800, 1200 and Super Nova) and the sys-20 for Digital Equipment's PDP-11 line. The 1 million word 10 is reportedly compatible with the Nova's 4019 disc and control units, while the 1M 20 is a direct replacement for DEC's RF-11/RS-11 or RC-11/RS-64. GENERAL INSTRUMENT CORP., Hawthorne, Calif.

FOR COPY CIRCLE 202 ON READER CARD

IC Interconnections

Equipment designers faced with design alternatives for connecting integrated circuits, to boards or cables or whatever, are offered this 12-page brochure on the subject from a vendor claiming to have manufactured more than 100 million interconnection devices since 1965. Though strongly sales oriented, the brochure is educational and interesting. AUGAT INC., Attleboro, Mass.

FOR COPY CIRCLE 203 ON READER CARD

Communications Buffer

Data communications users can solve a variety of problems with the Comstor 1032, according to its manufacturer.

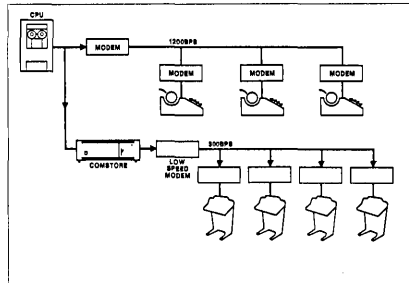

Some of the jobs the buffer is best at are code conversion, mixing line and terminal speeds, port sharing, adding addressability to a non-addressable terminal, message routing, and mixing synchronous and asynchronous terminals on the same line. An 8-page brochure describes how the 1032 handles data rates to 9600bps, understands Baudot, ASCII and EBCDIC, and can buffer either 40,000 5-bit characters or 20,000 bytes. INTERNATIONAL COMMUNICATIONS CORP., Miami, Fla.

FOR COPY CIRCLE 206 ON READER CARD

Daisywheel Printers

As described in this issue's survey of hardcopy terminals, some of the most interesting developments in terminals have been in the printer mechanism. Two of the printers that show up in such applications are the Sprint 45 and 55, which are fully explained in this 8-page booklet. The vendor is an oem supplier, but the brochure should also be of interest to end users needing serial printers. QUME, Hayward, Calif.

FOR COPY CIRCLE 204 ON READER CARD

Instrumentation Catalog

This detailed and handsome 48-page catalog presents the vendor's line of instruments and accessories, and also provides miniature articles describing their use. Products included are counters, digital multimeters, signal sources, power supplies, signal processors and oscilloscopes. Copious specification data and comparison charts are provided. TEKTRONIX, INC., Beaverton, Oregon.

FOR COPY CIRCLE 205 ON READER CARD

Minicomputer Applications

A 12-page booklet, "Computer Solutions for Elementary/Secondary Schools," summarizes this vendor's education-oriented minicomputer systems and instructional and administrative software. Available hardware and software for the Model 2000 access time-sharing systems and Model 3000CX mini data centers are discussed. Sections on computer simulation games, computer assisted instruction, and H-P user services are included.

A 16-page brochure describes H-P's BASIC software systems for its Series 2100 minicomputers and Series 9600 measurement and control systems. Specific applications are discussed, and practical problem-solving explanations are given. Time and event scheduling, multi-terminal I/O, multi-user operations, distributed systems and implementation and control are covered. HEWLETT-PACKARD CO., Palo Alto, Calif.

FOR COPY CIRCLE 207 ON READER CARD

Telephone Line Failures

A brochure of interest to 4800 and 9600 bps data network users discusses how to spot trends in line degradation which is often the key to preventing line failures. Oscilloscope photos of transmitted data with various kinds of line distortion are shown, and how to identify typical line degradations such as amplitude and delay distortion, harmonic distortion, noise, and phase jitter are explained. INTERTEL, INC., Burlington, Mass.

FOR COPY CIRCLE 208 ON READER CARD

Microfilm Readers

Four portable models are described in the brochure, "New Kodak Ektalite 200 Series Readers Help Bring the World of Microfilm into View." Magnification degrees, dimensions, and other physical characteristics of the models are given. EASTMAN KODAK CO., Rochester, N.Y.

FOR COPY CIRCLE 209 ON READER CARD

Uninterruptible Power

A 12-page booklet presents a management overview of UPS. The need, typical applications, how it works, and costs are discussed. INTERNATIONAL POWER MACHINES CORP., Mesquite, Texas.

FOR COPY CIRCLE 210 ON READER CARD

TWX & Time-sharing Modem

A modem designed to replace the Bell System Model 101C Data Set is described in a brochure. The modem allows any terminal to operate on the TWX network and over the Direct-Dis-

source data

tance-Dial (DDD) telephone network for time-sharing. Other capabilities are also detailed. OMNITEC CORP., Phoenix, Ariz.

FOR COPY CIRCLE 211 ON READER CARD

Microforms

Microforms 1975 is a 120-page catalog of newspapers available on microfilm, periodicals on microfiche, special scholarly microform collections, and microform support products. BELL & HOWELL, Wooster, Ohio.

FOR COPY CIRCLE 240 ON READER CARD

Data Entry

An illustrated brochure describes this vendor's 3300 programmerless data entry system, including features which allow preparation and creation of files and formats on a keystation screen. Also detailed are the editing, table lookup, printing, and hardware features. INFOREX, Burlington, Mass.

FOR COPY CIRCLE 241 ON READER CARD

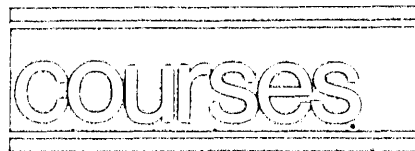

Process Computer Home Study

A three hour process computer course on audio tape describes the basic components common to any computer, whether for dp or process control. Communications devices, instruments to measure and control process performance, programming language, and computer operating systems are explained. No prior knowledge of computers is assumed. Course materials include four tape cassettes and a 100-page illustrated workbook which includes 10 self-check quizzes. Price: \$125 (workbook alone is \$25). Quantity prices available. HONEYWELL PROCESS CONTROL DIV., 2222 W. Peoria Ave., Phoenix, Ariz. 85029.

Systems & Procedures

A self-study course, *Basic Systems and Procedures*, covers the design and implementation of new computer systems; evaluation and improving of existing systems; the techniques of aerospace management applied to systems development; and how to avoid cost overruns, schedule delays, and user dissatisfaction. The price for this 20-hour course is \$55 (\$50 for AMA members). AMERICAN MANAGEMENT ASSN. EXTENSION INST., 135 W. 50th St., New York, N.Y. 10020.

Women in Management

A three-day seminar on the fundamentals of motivating, planning, controlling, and delegating, especially designed for women, will be held in Dallas (Dec. 8-10), New York (Dec. 15-17), and Los Angeles (Jan. 5-7). In addition to essentials of supervising, techniques for handling women's special management situations will also be covered. The panelists, all successful managers, will discuss their experiences in overcoming difficulties as women managers, influences that shaped their individual management styles, and psychological aspects of women's management problems. Fees: \$450 (\$390 for AMA members); team

fees available. AMERICAN MANAGEMENT ASSN., 135 W. 50th St., New York, N.Y. 10020.

Project Management

A customized, in-house, two-day seminar/workshop on project management covers planning, scheduling, controlling manpower, and budgeting time and money. Conducted for up to 20 executives, the topics include defining project scope, exercises in critical path networking, computer processing of these networks, project organization, and project accounting. Fee: \$2,500. PLANALOG CORP., 1400 Mill Creek Rd., Gladwyne, Pa. 19035. *

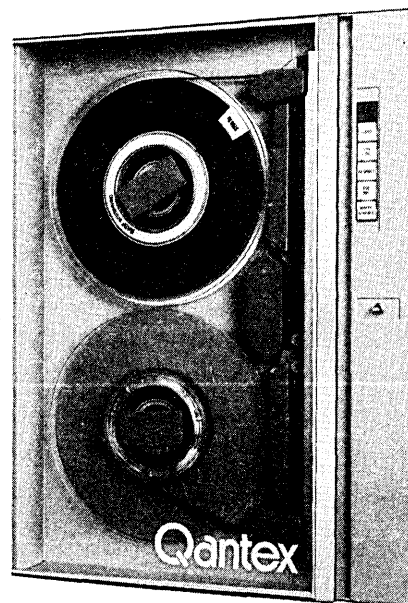

**HIGH RELIABILITY
LOW COST**

75 ips

**7- & 9-TRACK
TAPE DRIVE**

NO VACUUM COLUMNS

OR TENSION ARMS

That's right! The Qantex TDX tape drive with 75 ips read/write and 300 ips rewind speeds has no vacuum columns or tensioning arms. How? With a unique patented Floating-Shuttle™ tape buffering technique. This time-proven technique assures through its simplicity, high performance, high reliability, and low cost.

In field use for 2 years, the TDX is available for NRZI (800 bpi) and Phase-Encoded (1600 bpi). It is compatible with IBM and ASCII codes, and has no program restrictions. Of course, the interconnects are industry standard. Call or write today for full data and price information on the TDX, its Formatters and Controllers, and the militarized version meeting MIL-E-16400.

Qantex

THE PERIPHERALS DIVISION OF NORTH ATLANTIC INDUSTRIES, INC.

200 TERMINAL DRIVE, PLAINVIEW, NEW YORK 11803 • 516-681-8350
CIRCLE 98 ON READER CARD

Your Computers Can Now Finally Talk To Each Other In Their Own Digital Language Instead Of The Voice Language Of Humans With...

DatadialTM

Voice grade lines for data communicationsswitched or dedicated...are a thing of the past! When you switch your data communications to Datadial...the nation's only digital switched dial-up service...every time you dial-up you'll have instant connectivity via the highest speed, highest quality digital transmission system obtainable anywhere. And, with virtually error-free performance. Forget the noise, crackling, interference, jitters and confusion of voice grade lines.

Datadial speaks in the language your computer will understand...with an economy that your accountant will understand, too.

Write or call: DATRAN, Data Transmission Company, 7200 N. Stemmons, Suite 300, Dallas, Texas 75247, (214) 634-7390

Special Datadial Features:

- Unprecedented cost savings...pay only for the time you use Datadial.
- Total end-to-end communications service.
- Transparent data channel.
- Full range of speeds up to 9,600 bits per second.
- Full duplex.
- Connect time less than one second.
- Billing in one second increments—one cent minimum.
- Automatic answering and calling.
- Automatic call back.
- New level of data security.
- Abbreviated dialing.
- Rotary.

The Switch Is On!

DATRAN

Important things to consider about terminal work stations...

1. Correct Keyboard Height
2. Convenient Viewing Height
3. Adequate Work Surface
4. Storage Space for Modems and Dataphones
5. Access to phones, files and reference material.

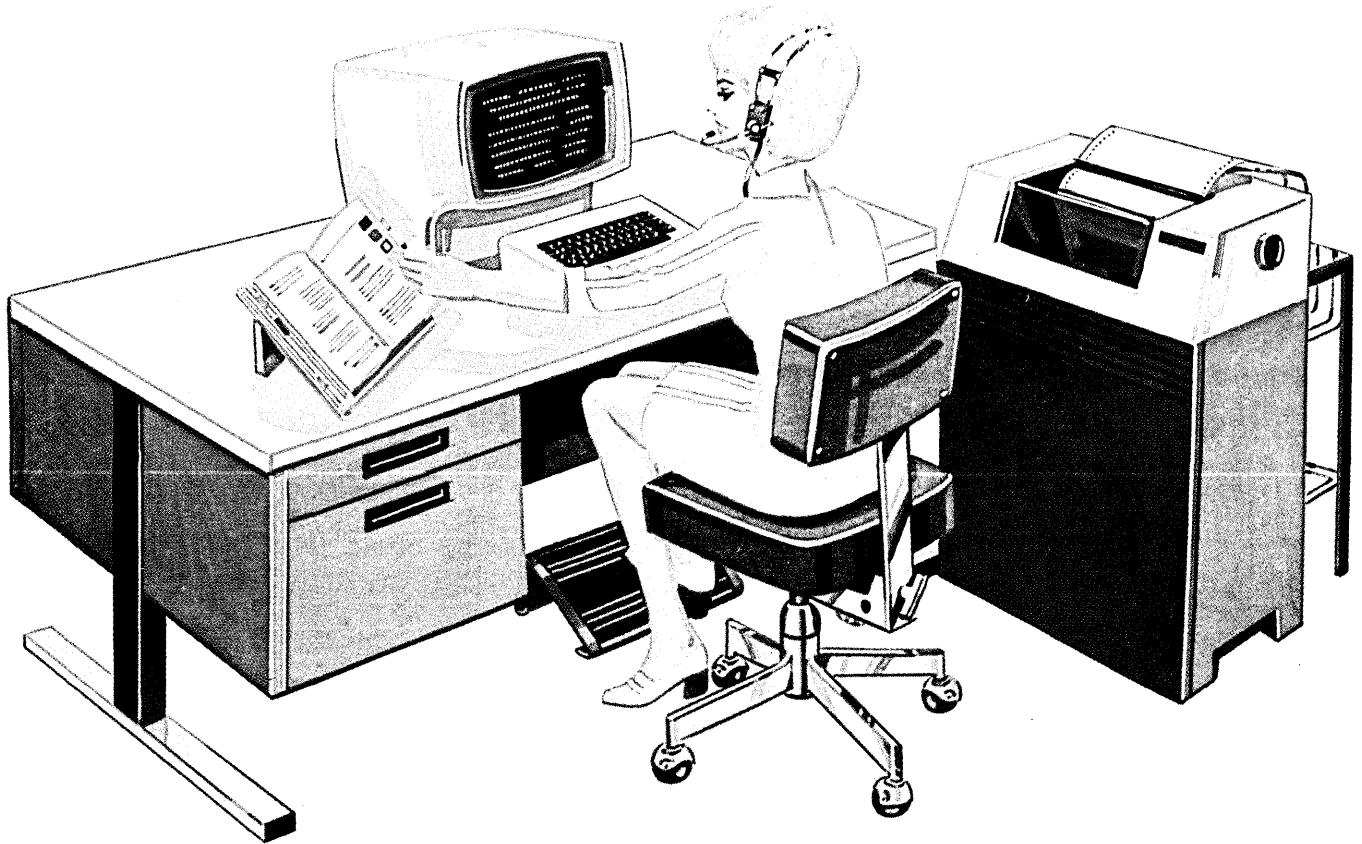

...and how to be sure you get them

To get the best operator performance and productivity, proper work environments are essential for your CRT terminal operators. Wright Line Terminal Work Stations are recommended by leading terminal manufacturers. They are specially designed to provide proper viewing and keyboard heights, adequate work surface, storage space for modems, other electronic equipment and personal effects.

A wide variety of configurations is available, including swivel tops to allow access by more than one operator.

Circle readers' service number or write direct for illustrated brochure.



Hello, IBM.

ADDS introduces the first truly low cost CRT terminal for the IBM user.

We've been waiting a long time to say this:

Hello, IBM!

There, we finally said it.

You see, IBM (we almost feel like we should call you "sir") Applied Digital Data Systems (that's us) now has a terminal for IBM users. Wait'll you see it.

It's called the 980A. And, it's packed with the features that helped ADDS carve a reputation in the Teletype[®] compatible market. Sharp, readable screen with upper and lower case character display. Line as well as character insert/delete. Not to mention blinking, formatting, and patented graphics.

Compatibility?

The 980A looks just like a 3270 to the telecommunications access method (BTAM, TCAM, etc.) and to such real time monitors as CICS. It can even operate on the same phone line as 3270's.

However, since your 3270's don't have blinking, lower case, graphics (or most other special 980A features, we might add), applications software developed to support the 3270 won't support our 980A. So we don't think we'll be replacing many of your 3270's.

But, the IBM user can develop new applications around the 980A. And the reason we think he should (here's where you get

nervous again) is quite simple. The 980A offers unmatched features at an extremely low cost. Namely, \$3200.00 to purchase, \$90.00* a month to lease.

And all of our units are serviced by NCR.

That's pretty much why we think if our shoe fits, the IBM user's going to wear it.

Because even though you're very, very good, IBM, there's always room for a little improvement.

Sir.

Hello, ADDS.

I may have a new application for your 980A.
Please send additional information.

Name _____

Company _____

Address _____

Zip _____

Applied Digital Data Systems Inc.
100 Marcus Boulevard, Hauppauge, N.Y. 11787

ADDS

*3 year lease-purchase not incl. maint.

CIRCLE 11 ON READER CARD

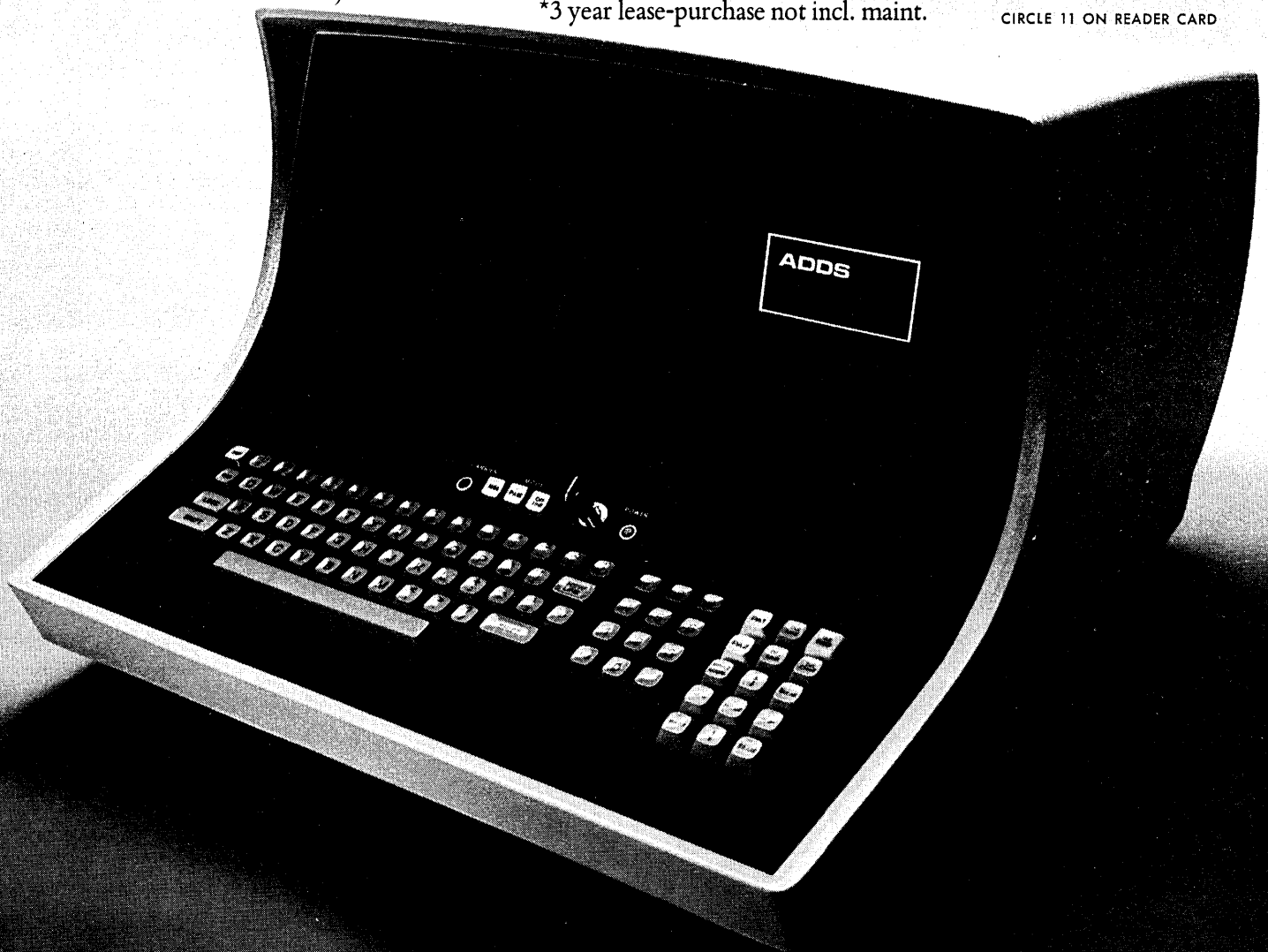

Even if your building survives, your business may die.

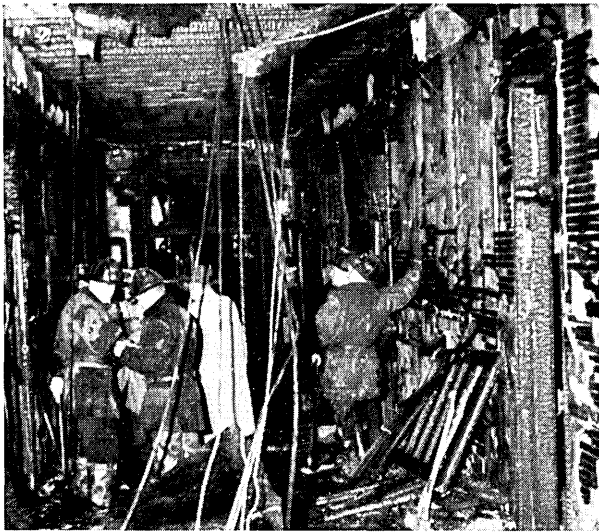

The gloomy fact is, even a minor blaze can cause enough damage and business interruption to close you down for good.

It happens every day. To all kinds of businesses.

Because there's just no such thing as fool-proof fire *prevention*.

For this very reason, you need a fire *protection* system that quenches the flames faster. Before they can do extensive damage. And allows you to get right back to work. With no clean-up. And a minimum of downtime.

Fenwal Fights Fire with Halon

The Fenwal Fire Suppression System does both. Because it uses Halon 1301. A chemical you may have seen demonstrated on TV. When released as



a vapor by a Fenwal system, Halon literally snuffs out flames. Faster than water. Faster than CO₂.

Faster than anything yet developed. And dry — no wet mess to clean up.

Safe for Even Delicate Things

What's just as important, Halon 1301, unlike water and CO₂, won't damage whatever it is you're trying to protect.

Sensitive equipment. Sensitive material. Sensitive anything. And it won't harm people.

Putting a Damper on Downtime

This all adds up to two very important advantages you don't get with other fire protection methods: 1. A Fenwal system gives you the fastest jump on the flames because you don't have to evacuate the area before it's released.

2. *You can go right back to work. There's no clean-up. No water damage. No extensive business interruption.*

Now Make Us Prove It

We believe our Halon Fire Suppression Systems are the solution to a lot of serious fire problems.

We've been designing and installing them for years. More systems than any other manufacturer. And we've perfected a number of different systems to protect all kinds of environments.

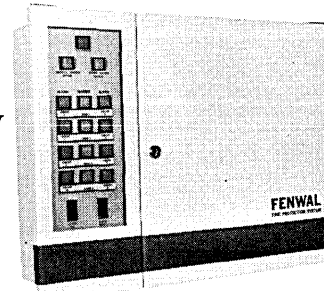

Quite simply, they work.

We make sure of that. Before we install them. And after. With the best after-sales back-up in the business.

What's more you can't ever outgrow a Fenwal system because they're modular in design. Easy to extend.

Of course no one's ever bought any fire protection system after reading a one-page ad.

So we've prepared a special film which shows our system in action.

It proves you can save your building without killing your business.

To view "The Fireaters" just call us at (617) 881-2000. Or write Fenwal Incorporated, Ashland, Massachusetts 01721. A Division of Walter Kidde & Company, Incorporated.

FENWAL

Nobody in the world has more experience in fire and explosion suppression systems.

Our local, service-oriented distributors are listed in the yellow pages under "Fire Protection".

FM Approved—UL Listed

The new package from the leader:

Precision Graphics at an alphanumeric price.

Not just graphing. Graphics from the graphics specialist. The key is information capacity. Tektronix' new 4006-1 offers far and away the highest output density of any terminal in its price range: 1024 X by 780 Y viewable points; 2590 alphanumeric on screen characters.

It's all you'd expect from the company serving all your graphic needs . . . priced competitively with most alphanumerics.

Immediately compatible with most mainframes. Thanks to proven interfaces. Time-tested software. Great new usable software packages. And expert maintenance anywhere in the world.

And rely on Tektronix to do it right. The 4006-1 is our biggest breakthrough towards making the power of graphics affordable for everyone. Just \$2995

for openers. Lease price \$150 per month on a two year lease, includes maintenance. Plus peripheral options like our 4631 Hard Copy Unit for up to four 4006-1's, with 8½" x 11" copies, and 4923 Digital Cartridge Tape Recorder. And as fine a package of technical support as you'll find for any terminal anywhere.

Check it out: we're graphic leaders for some mighty good reasons. Your local Tektronix Sales Engineer can give you the whole story. Or write:

Tektronix, Inc.
Information Display Group
P.O. Box 500
Beaverton, Oregon 97077

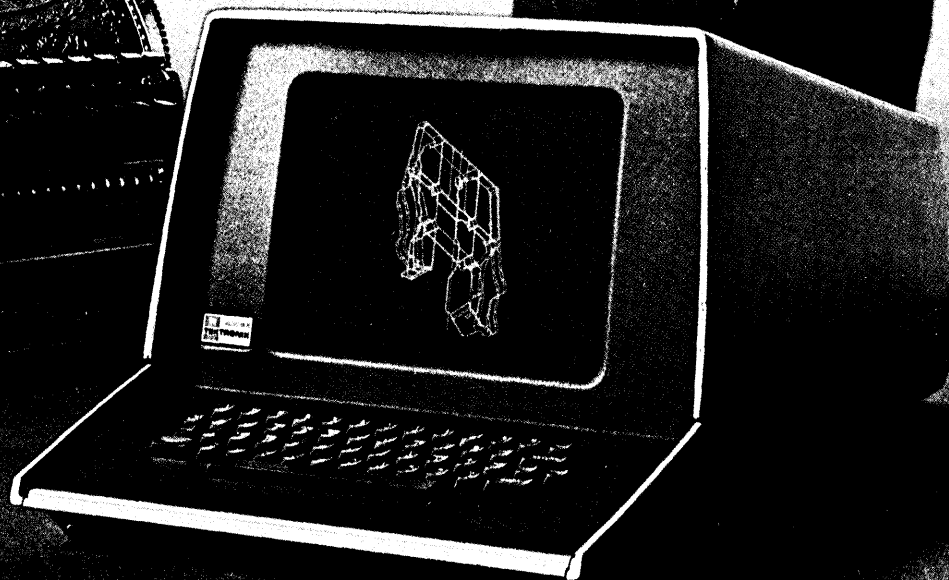
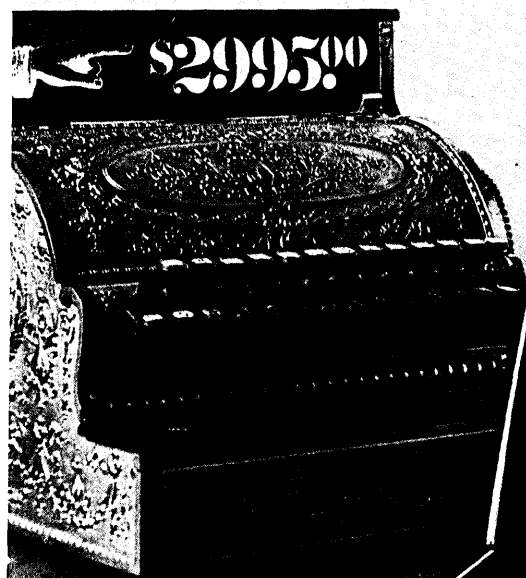

Graphics
Terminal
Info

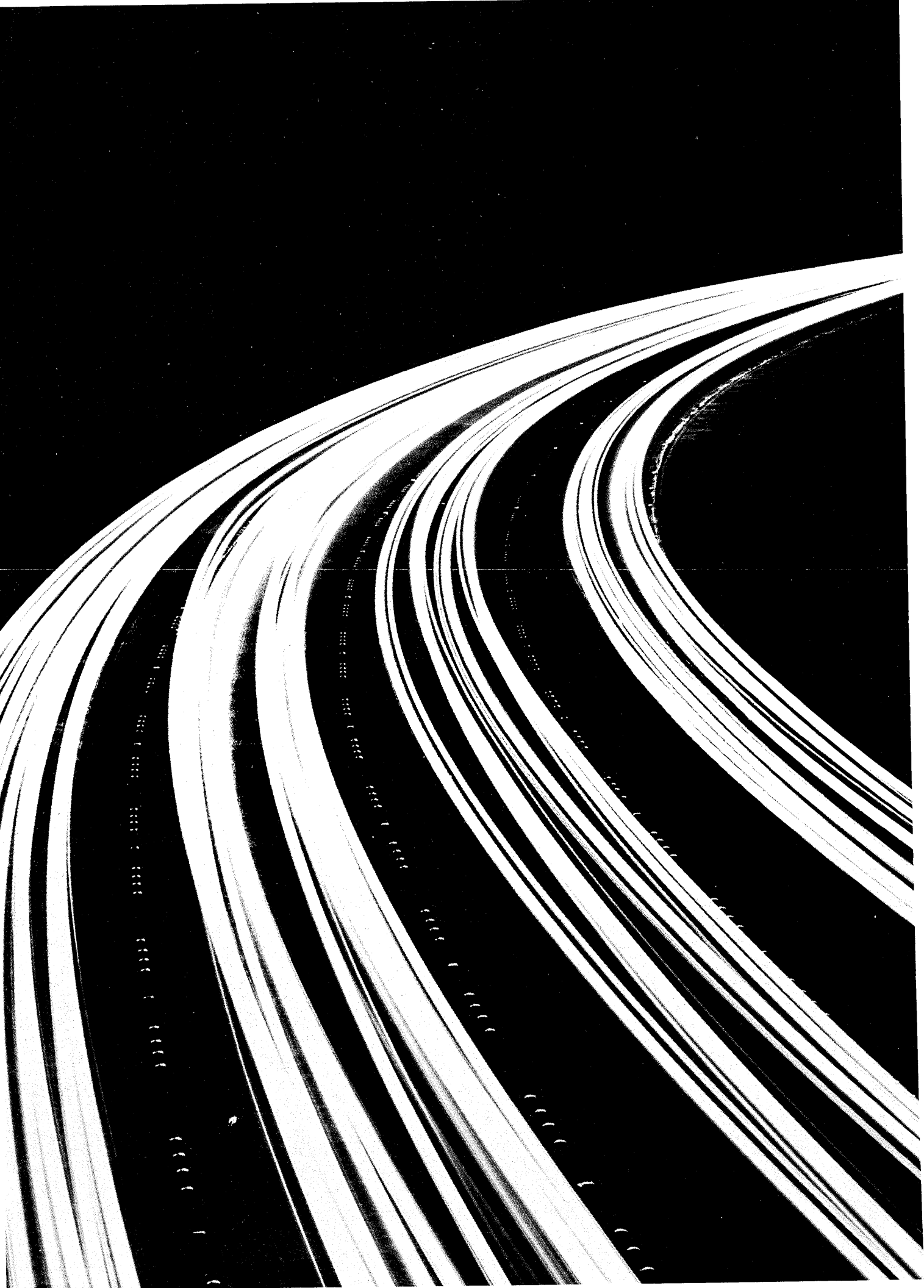

Build your timesharing system like a freeway.

The BTI 4000 interactive timesharing system offers you an orderly, straightforward way to grow. It's available in 16-port increments, from 16 to 256 ports. And adding ports is like adding lanes to a freeway: all the original equipment is retained, and a complete parallel system is "plugged in." Port capacity is doubled, tripled, or more.

This efficient approach to growth is made possible by BTI's unique mass memory data bus, which allows "clustering" of systems to share processor and mass storage resources.

Just as a driver can use any lane on the freeway, your users can be handled by any available port in the system. To each user, the clustered system looks like a single system.

System mass storage can be expanded just as simply. The minimum storage is 5 million bytes and maximum capacity is over 4 billion bytes. You can expand in increments of 2.4, 36 or 73 million bytes.

Users will appreciate the capability of the 4000's BASIC-X language—a powerful extension of BASIC created and continually improved in response to timeshare users' needs.

BTI 4000. Expandability from 16 to 256 ports. Software a programmer can love. 10¢ per terminal hour ownership costs—including 24 hour service availability.

Get all the facts on our system before you buy or lease any system.

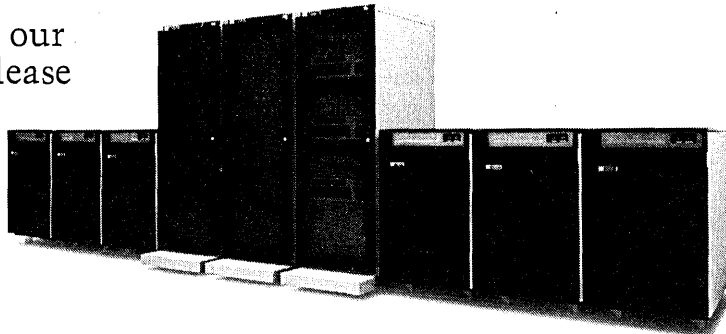

BASIC Timesharing

Timesharing systems built by the company with timeshare experience.

Home office: 650 North Mary Avenue, Sunnyvale, California 94086. Sales offices: East: Cherry Hill, New Jersey (609) 795-2334; Southeast: Atlanta, Georgia (404) 433-0900; Midwest: Schaumburg, Illinois (312) 882-2111; West: Sunnyvale, California (408) 733-1122

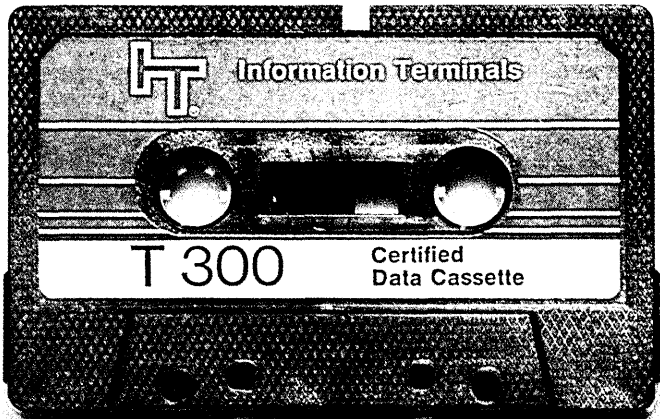

T Series: Has achieved worldwide reputation as the standard (ANSI and ECMA) against which the performance of all other cassettes is measured. More in use than any other digital cassette.

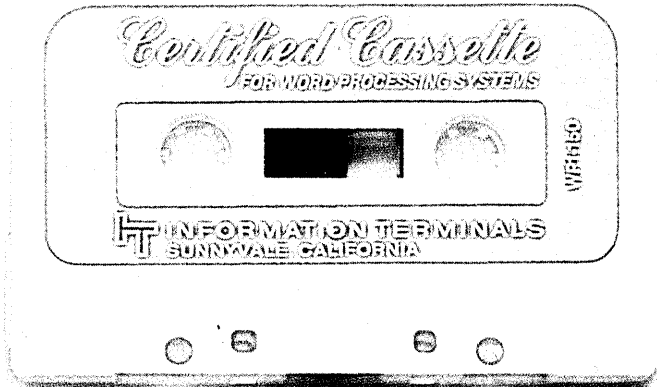

WP Series: High quality cassette for word processor or text editing systems using ten inches of clear leader and one-mil recording tape.

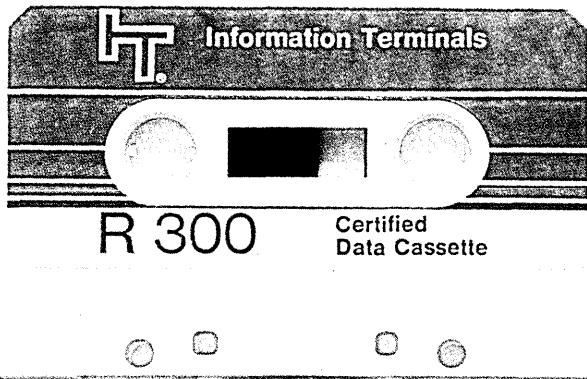

R Series: Lower-cost certified cassette, also meeting ANSI and ECMA standards.



NLT Series: Leaderless design for use in Wang or equivalent programmable calculators. Same high-performance features as T Series.



H Series: Operates in extremely hostile environments—65° to 160°F, where performance standards substantially exceed that of normal usage. Compatible with ANSI, ECMA and ISO standards.

These five cassettes represent more than half of all the certified digital and word-processing cassettes in use throughout the world today.

Just something to think about when you buy cassettes... tomorrow.

Information Terminals Corporation
 323 Soquel Way
 Sunnyvale, California 94086
 (408) 245-4400

Editor's Readout

John L. Kirkley, Editor

Civil War in the Corporation

"And we are here as on a darkling plain
Swept with confused alarms of struggle and flight,
Where ignorant armies clash by night."

Back in the 19th century when Matthew Arnold wrote those lines, the world wasn't exactly into data processing.

But it is now. With a vengeance. And perhaps as some of you read those lines, you felt a sudden flash of recognition. Do they sound like a florid but accurate description of the relationship between your dp department and your company's management? As a member of the business data processing fraternity are you engaged in a covert civil war (or maybe an all-out fire fight) with your users? If you are, you're not alone. It's a problem that's been around for a while and seems to be getting worse even though data processing within the business environment is still in its early stages of evolution.

Like a hyperkinetic child reacting to an over-demanding parent, there's tension in the family.

Ask almost any dp manager what his biggest headache is and, as he reaches for the Alkaseltzer Plus, he'll tell you that it's not equipment failures, or improving programmer productivity. *It's those users who ask him to solve problems that they themselves have not even defined yet.*

Why, he'll say, waiting for the fizz to subside . . . why can't they learn a little discipline . . . why do they have to change their minds and their requirements so often? Why don't those ignorant armies acquaint themselves with the capabilities (and limitations) of this wondrous utility they have at their fingertips? Why must they demand the impossible and then scream at costly overruns and delays?

But when you travel across no-man's land — littered with the burnt-out hulks of shattered projects — and pay a visit to the user encampment, you'll hear a different refrain.

The mystique has worn off. Once upon a time for many corporate executives, having a data center was an expensive but exhilarating ego trip; it was enough just to watch the tapes whirl and the console lights blink. But now, in a bottom-line world, he recognizes that data processing is but one of the important links in the operation of his organization.

And so he and his managers complain that the dp man still lives in that inaccessible, esoteric world of bits and bytes like a latter-day Merlin surrounded by magical devices. Those in the dp department, they say, identify themselves with the world of data processing, not with corporate thinking and goals — they march to a different drummer. And they use too much jargon . . . on purpose.

Dp managers, say the users, must understand that their services are only one element in any project. And, from the project manager's bird's eye view, it is often wiser to trade off some extra costs incurred by the inefficient use of dp in order to save money in the long run. "So don't talk to me about cpu utilization" says the project manager, "just get the damn job out by tomorrow morning."

A breakdown in communications? Sure. And history tells us that when people stop communicating, they start shooting. But before you throw up your hands, put your helmet back on and return to the trenches, consider for a moment what might be done. And what others are doing.

Some companies now have a dp director (along with a dp manager). The director's unenviable job is to act as a bridge between dp and the rest of the company's management structure — he's a very battered individual. Some companies are moving analysts and even programmers out into the user departments. Others have set up joint advisory panels (with little success).

We'll examine these and other attempts to establish a truce, if not peace in our time, in future issues of the magazine.

If any of this has a familiar ring to it, let us hear from you — we'd like to know about your experiences; and if you and your management have come up with some effective techniques to bridge the gap, we'd like to pass them along to your beleaguered colleagues out there on the firing line.

In the meantime continue working on those communications lines.
And keep your powder dry.

The Computer Terminal Industry: A Forecast

by Roy M. Salzman

By 1980 terminal sales will more than double, and will account for almost one quarter of total hardware expenditures.

The computer terminal field is often discussed as a dynamic, rapidly growing area. Although it strongly impacts the mainframe computer systems industry, the communications industry, the office automation industry, the data entry equipment industry, and several automation-intensive industries such as retailing and banking, it is rarely defined and quantified as an "industry" in its own right. In spite of difficulties in doing so, it seems worthwhile to try, since there is an increasing linkage among various types of terminal products, as well as a distinct differentiation between terminals as a class and other portions of the computer/communications field. Terminals are typically excluded from market estimates of computer systems, communications products, office automation equipment, and specialized industry-oriented equipment, but since they represent a significant and growing market value, it is important for firms in all of these markets to be aware of their potential.

Arthur D. Little, Inc. recently conducted a comprehensive study of this industry to (1) separate the plethora of terminal types into useful categories, (2) estimate the current and future markets for each, (3) project the effects of technological advances and user trends on the characteristics of the products, and (4) analyze the strategies of major vendors or classes of vendors in the industry.

This study defined the terminal industry somewhat more broadly than others have done, to include not only the conventional crt, teletypewriters, and remote batch terminals, but also display terminals used as data entry devices, graphics displays, portable teletypewriters, interactive terminal systems controllers (such as the IBM 3790 system), and various industry-specialized devices such as supermarket checkout systems, automated bank

teller devices, and industrial data collection systems. This was considered necessary because these latter types of devices appear to be growing in market potential faster than the older style general-purpose terminals and already constitute important areas of opportunity for terminal vendors.

Under this broader definition, the ADL estimate of the range of the total marketplace is shown in Fig. 1. The breakdown of the midpoints of the ranges in 1975 and 1980 by major terminal categories is given in Table 1. Table 1 also gives estimates of the installed population of each major category as of the end of each of the years.

Vendor strategies

This market forecast, when combined with the forecasts for general-

purpose computer shipments as shown in Fig. 2, indicates that a much larger proportion of the total value of systems will be accounted for by terminals. Hence this area will be of increasing interest to mainframe computer manufacturers, including minicomputer manufacturers. These vendors will need to capture a major share of the sale of terminals for use with their computers in order to maintain their revenue stream for total systems. They must also offer competitively attractive terminals to effectively market their systems to users who will make vendor selection decisions heavily weighted by the terminals proposed.

IBM, among others, has recognized the trend. It has recently emphasized terminals and other communications-oriented products (hardware and soft-



IBM is expected to tie terminals closely into networks involving IBM host processors, thus ensuring for itself a large share of the growing terminals market. A "cluster" of IBM 3270 keyboard/displays is shown.

ware) as characterized by its SNA (Systems Network Architecture) announcement. SNA and its likely implications for the future suggest that IBM will attempt to tie terminals closely into networks involving IBM host processors. This would be accomplished by having the hosts produce software that requires IBM microcomputers in the terminals to execute that software correctly.

Thus, the user will be strongly induced to use IBM terminals if he plans to develop modern communications networks centered around IBM mainframes using the many virtues of SNA—such as centralized terminal diagnostics, network-wide data security measures, efficiently distributed operating systems functions, and the use of SDLC communications protocol. Other mainframe manufacturers such as Burroughs, DEC, and Honeywell are similarly developing communications network products and terminals to try to capture as much as possible of the growing terminals market.

Meanwhile, other well-entrenched terminal vendors are developing strategies and products to extend their own market shares in the industry. AT&T's Teletype Corp. in particular is aggressively seeking to reestablish its strong position in the terminal industry (developed as a result of the popular Model 33 and 35 keyboard/printers) with its impressive Model 40 terminal providing both visual display and hardcopy output.

This product, which has thus far been primarily sold internally to Bell System operating companies, should

begin appearing on the general market in large numbers to compete against display terminals which have been replacing the Model 33s and 35s as well as against other non-tty compatible display and printer terminals.

Teletype has announced several enhancements to the initial asynchronous, standalone terminal (a 4800 bps bisynchronous version and a cluster controller), and has hinted at other improvements (e.g., a 132 column printer, cassette storage, and SDLC compatibility) to broaden the Model 40's appeal.

The so-called independents, including many divisions or subsidiaries of large electronics, communications, and peripheral equipment companies, are also attempting to strengthen their positions in the industry. Their opportunities will no doubt be narrowed by increasing difficulties in achieving IBM-compatibility under the SNA concepts, by Teletype's increased competition in the Teletype-compatible field, and by other large mainframe and minicomputer vendors forcing the use of their own terminals on their systems.

However there are still some strategies by which the independents can survive and prosper. One such strategy is to continue to supply low cost "second-generation" terminal equipment to users who do not yet choose to move on to the more sophisticated network concepts but merely wish to extend and enhance their current terminal networks. Another is to move into specialized industry-oriented terminals which, as shown in Table 1 and discussed later, seem to have greater

growth opportunities than the general-purpose devices. Yet another would be the extension of their marketing efforts to foreign markets which are at a slightly earlier stage of terminal systems implementation, thus offering a potentially longer lifetime for current technology terminals.

One product development strategy which appeared extremely popular is the use of microprocessor and mini-computer technology to build highly powerful controllers at relatively low cost. These controllers not only control a variety of terminal types and local peripheral equipment, but also perform applications-oriented functions in a quasi-standalone capacity.

This method of operation has the appeal of reducing both the interdependence between the terminals and mainframe software, and also the communication network requirements. It requires the terminal vendor to develop many capabilities he did not need as much before, such as micro-computer systems engineering skills, operating systems and applications software expertise, and customer support personnel.

It also means that these products are dependent upon relatively sophisticated users who are able to cope with concepts of distributed intelligence, local files which must be coordinated with centralized data bases, determination of editing rules that can be applied at the local levels, etc. Such users are relatively rare and, even if identified, will require a great deal of support to get into these advanced modes of operation.

Market structure

The breakdown of the market given in Table 1 can be further subdivided into 16 distinct product categories with characteristics as follows:

Keyboard/Printers

- Simple—Alphanumeric keyboard with character or line-at-a-time hardcopy printing (impact or non-impact). May be unbuffered or internally buffered up to a few lines for transmission efficiency. May also include external data storage medium (paper tape, cassette, cartridges, or diskette device) for off-line recording and batched transmission. Includes such devices as: Teletype 33, 35 and 38; IBM 2740, 2741, 3767, 3793; GE Terminus Series; Univac DCT Series; DEC LA 36; NCR 260; TI 733; Centronics 101, 306, 500; and many others. Prices range from \$700 to about \$5,000, with an average at about \$2,000.

The market is expected to begin diminishing after 1975, becoming largely a replacement market. The use of microprocessors will cause an increasing overlap between this segment and the

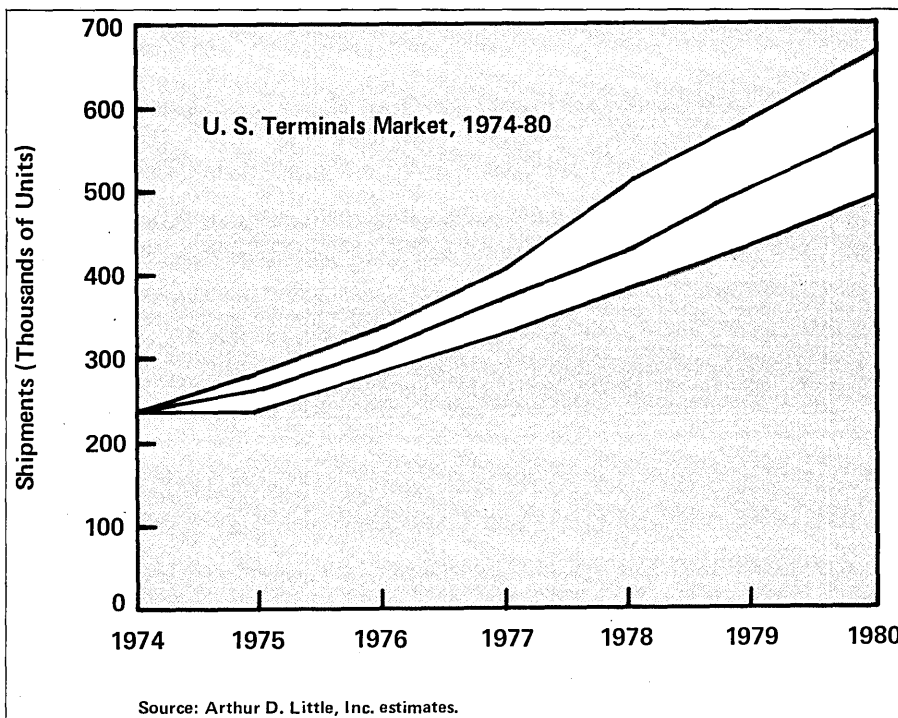

Fig. 1. The market for computer terminals in the U. S. is expected to more than double by 1980.

A FORECAST

programmable keyboard/printers.

- **Programmable**—Same capabilities as simple keyboard/printer plus a user-programmable processor for tailoring the terminal to a specific application. Usually also contains some form of external data storage medium for local table or file storage. Includes such devices as: the Burroughs TC 600, 3500; IBM 3735; Data Measurements DMC 400, Qualterm X100, Compro 1030, 6000; and Texas Instruments 742. Prices range from \$4,000 to over \$15,000, with an average price of about \$10,000.

- **Terminal Systems Controllers**—The market is expected to grow strongly from a small base but modestly in absolute terms, since most needs for terminal intelligence will be satisfied by intelligent display terminals with hardcopy options or by simple keyboard/printers controlled by interactive terminal systems controllers. Considerable price reductions seem possible as a result of advances in microprocessor technology; increases in printing speed and quality are also anticipated along with increased file capacity.

- **Portable**—Same capabilities as simple keyboard/printer in a device weighing less than about 30 pounds and packaged for easy carriage (e.g., in a suitcase). Acoustic coupler is normally built in for telephone handset connection. Includes such devices as: the TI 735; Computer Devices 1060; CTSI Execuport 300; NCR 260-5; RCA Service Co. Extel Teleprinter; Anderson Jacobsen 630; Dataproducts Portacom. Prices range from \$1,500 to \$4,000, with an average price of about \$3,000.

The market is growing relatively slowly because it is being impacted by

electronic calculators (since many of these devices are used for time-sharing computation) and small displays such as the new IBM 5100. Technological developments will include the incorporation of an integral cassette drive, modest increases in printing speed, and more use of plain paper non-impact printing techniques.

Display Terminals

- **Data Entry**—Keyboard/display work stations oriented toward pure data entry (including initial keyboarding, verification, editing, correction, reformatting, and supervisory functions) on a standalone basis or supported by a shared processor; normally user-programmable through parameter designations or a specialized data entry-oriented language; remote communications may or may not be involved. This category does not include general-purpose display terminals used for on-line data entry applications. Included are such devices as: the Inforex 1300 and 3300 series systems, Computer Machinery Corp. Key Processing Systems, Entrex Systems, Mohawk 2400, Sycor 340, Four-Phase IV-40 and 70, IBM 3740 and its new 3760, General Computer Systems 2100, etc. Prices range from \$2,000 (for a shared processor work station) to \$10,000 (for a standalone data entry device), with an average of about \$3,000.

The market is expected to continue to grow very rapidly for the next two to three years as users replace most of the conventional keypunch or key-tape approaches with these clearly superior devices, then start to slow down as on-line data terminals and source data automation methods reduce the need for centralized or dedicated data entry operations. Price reductions to an average of \$2,000 per station and increased data editing and pre-processing

functions can be expected as a result of microprocessor and diskette cost-performance improvements.

- **Teletype and Teletype-Compatible**—Keyboard/displays operating in an asynchronous transmission mode with ASCII code, generally designed and used to replace Teletype Model 33 or 35 keyboard-printers, many of them being plug-to-plug compatible with those devices. Also includes the Teletype Model 40 (or Dataspeed 40 as it is designated by the Bell Telephone Companies that offer it as a tariffed service) even though it is not directly compatible with the 33 and 35, since it represents an important competitive threat to the vendors of display terminals in this category. Typical examples include: the Hazeltine 1000 and 2000, the ADDS Consul 580 and 880, the Lear Siegler ADM 1 and 2, the Datapoint 3300 and 3000, the Beehive Minibee, the Hewlett-Packard 2640A, and many others. Prices range from \$1,500 to \$4,000, with an average price of about \$3,000.

The market is heavily dependent on Teletype's success with its Model 40 since the major wave of Model 33 replacements has taken place; aggressive marketing efforts by Teletype should stimulate strong growth in broader applications areas. The use of microprocessors to permit paging, scrolling, SDLC compatibility, more peripheral device control, etc., should increase its applicability and attractiveness; lower priced displays may also be possible for price reductions of basic units.

- **IBM and IBM-Compatible**—Keyboard/displays operating in synchronous transmission mode, generally designed and used to replace IBM 2260 and 3270 series terminals; includes not only current IBM visual display terminals but future IBM products and competitive/compatible devices. Includes such devices as: the IBM 3270 and

	1975				1980			
	Shipped		Installed		Shipped		Installed	
	Units (000)	Value (\$000,000)	Units (000)	Value (\$000,000)	Units (000)	Value (\$000,000)	Units (000)	Value (\$000,000)
General Purpose								
Keyboard/Printers	106	246	516	1,200	65	170	712	1,980
Display Terminals	80	370	377	1,990	312	1,115	1,200	5,000
Terminal Systems Controllers	7	370	25	1,245	15	580	78	3,420
Sub-Totals	193	986	918	4,435	392	1,865	1,990	10,400
Special Purpose								
Banking Terminals	8	130	51	720	24	335	125	1,980
Point-of-Sale Terminals	60	175	210	515	140	615	750	2,735
Industrial Data Collection	5	10	54	110	18	35	100	200
Sub-Totals	73	315	315	1,345	182	985	975	4,915
Totals	266	1,301	1,233	5,780	574	2,850	2,965	15,315

Source: Arthur D. Little, Inc. estimates

Table 1. Statistics on terminals in 1975 and 1980 broken down according to major categories reveal a forecast of sizable

growth in terminals of all kinds except for keyboard/printers.

3275, Sycor 250, Delta Data Systems 5300, Courier C270 and C275, GTEIS 7700 and 7100, Computer Optics 75 and 77, Trivex 40/80, Terminal Communications TC 275 and 277, and many others. Prices range from \$4,000 to \$9,000, with an average price at about \$6,000.

The market is expected to grow very strongly (over 30% per year) paced by IBM's increased terminal marketing efforts and introduction of a broad range of new products and software encouraging IBM mainframe users to implement the terminal-oriented applications they have been talking about and planning for years. IBM is expected to increase its market share in this category from 60-65% to nearly 90% through its enhanced product line, aggressive marketing, and the use of SNA concepts to encourage all-IBM networks. Flat-screen displays seem likely, as does a microprocessor-based intelligent display terminal and enhanced peripheral device options such as better printers and diskette devices.

- Other Inquiry and Conversational—Keyboard/displays for operation with non-IBM computers or operation in nonstandard ways with IBM computers (i.e., such that they would not be compatible or directly competitive with IBM-supplied terminals). This category is necessarily very broad and ill-defined, covering intelligent display

terminals as well as very simple inquiry-only terminals. Includes such products as: the Univac Uniscope 100, Sander 804 and 8100 systems, Raytheon PTS 100, Control Data 711 series, Data-point 1100, Bunker Ramo 2210 and MDS-7, Computek 200, Incoterm SPD 10/20, and a nearly endless list of others. Prices range from \$1,500 to \$4,000 for unintelligent devices, and from \$5,000 to \$9,000 for intelligent terminals.

The market should continue its strong growth as other mainframe and minicomputer vendors, like IBM, push terminals in their systems' offerings, and as independent terminal vendors encourage distributed processing with intelligent displays and controllers. Similar technological advances are expected here as with IBM and Teletype-oriented devices—namely the use of microprocessors for greater versatility, applications tailoring, and local processing power; the use of diskettes for local file storage; and the increased use of hardcopy options.

- Graphics—Display systems with keyboard and/or graphics input devices (light pen, stylus, etc.) for the display and manipulation of graphic (i.e., line drawings) as well as alphanumeric images. Includes such devices as the IBM 2250, Tektronix 4010 and 4015, Adage GP/400, Information Displays IDIOM and IDIGRAF, Sanders

ADDS 900, DEC GT-40, Vector General Series 3, Imlac PDS-4, Hughes Conographic System, etc. Prices range from \$10,000 to \$20,000 for limited function devices (non-dynamic displays), and from \$30,000 to over \$100,000 for full interactive devices, with an average price for all terminals in this category of about \$20,000.

The market is still quite questionable for this category as it has always seemed very promising but then turned out to be disappointing. A new graphics product by IBM could provide a strong stimulant to the field and improved software might facilitate broader market acceptance; but not too much optimism can be shown because of historically slow acceptance of these concepts.

General-Purpose Terminal Systems Controllers

- Remote Batch—Controller for batch-oriented I/O devices (card readers, line printers, storage devices) for transmission to and from a host computer and for limited standalone utility functions. Includes such devices as: the IBM 2780, 3770; DATA 100 Model 78, the Harris Cope Series 1200; the CDC UTS 200, 27801; Univac DCT 2000, Remcom (Computer Machinery) 2775/2780; Singer M&M 500 Series, etc. Prices range from \$40,000 to \$65,000, with an average of about \$50,000.

The market is expected to grow modestly until about 1977, then fall off rapidly as standalone small machines and interactive processing replace remote batch processing approaches. Not much technological advances are projected beyond enhanced processing capability in the controllers and SDLC compatibility.

- Interactive Systems—Controller for interactive terminals with a link to a host processor for master data base access and major processing functions; user-programmable for local device control and locally oriented applications functions. Includes such devices as: the IBM 3790; the Sanders 8000 Series; Raytheon PTS Series; Data 100 Keybatch System; Sycor 440; Xerox Intelligent Display System; and several others. Prices range from \$35,000 to \$60,000 (including batch-oriented peripherals and file storage devices but not terminals which are in the other categories), with an average of about \$50,000.

The market is expected to grow strongly after about 1977 as all vendors, including IBM, make a strong push for distributed intelligent network systems and users become sophisticated enough to learn to use such systems. Microprocessor and minicomputer technology will permit increased local processing power and local data

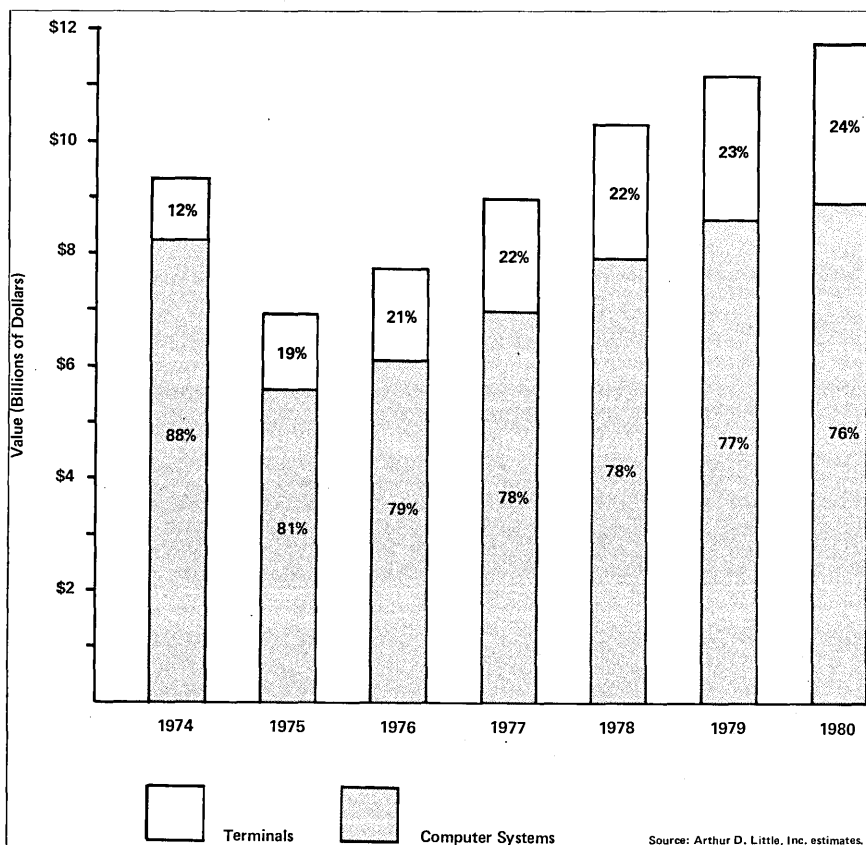

Fig. 2. In 1974, terminals accounted for only 12% of hardware spending. By 1980, they will comprise twice this percentage of total sales, which also will increase steadily toward \$12 billion annually.

A FORECAST

base control. Software developments will also focus on this concept to provide user or applications-oriented languages for programming the controller.

Banking Terminals

• **Automated Teller Machines**—Customer-operated bank teller devices that accept coded identification cards and/or keyed input to permit a variety of banking transactions, including the dispensing and accepting cash, to be carried out automatically. Includes such devices as: the Docutel Total Teller, IBM 3614, Mosler Teller-Matic, Burroughs RT Series, Diebold TABS, and several others. Prices range from \$17,000 (for simple cash dispensers) to \$40,000 (for full function automated tellers).

The market is expected to grow rapidly from a very small base, but nevertheless to stay at a relatively small installed base, since the devices are difficult to justify economically and are primarily installed for marketing purposes. There will be a trend toward more on-line usage of these devices by integrating them with total bank dp systems.

• **Teller Terminals**—Teller-operated terminals which facilitate a variety of teller operations and capture all appropriate data for master file updating purposes; they frequently incorporate receipt and/or journal printers along with other forms of teller feedback (e.g., crt display or indicator lights); they may also incorporate passbook or ledger card printers. Includes such devices as: the Burroughs TC, TCS, TT, TU Series; Bunker Ramo 2001, BSC 90; IBM 3600; NCR 270, 277 Teller Terminals; and many others. Prices range from \$3,000 to \$8,000 for limited function devices, and \$10,000 to \$15,000 for full function devices.

The market is expected to grow rapidly as banking automation builds momentum and reduced terminal prices make cost justification easier. Cheaper and more versatile display units, microprocessors to provide more flexible and lower priced logic, and improved printing devices should result in lower priced and more powerful terminals.

Point of Sale Terminals

• **Credit Verification**—Simple terminal devices which read credit cards or accept keyed account numbers, communicate with files of credit information, and indicate the level of credit purchase allowable. Includes such devices as: the AT&T Transaction Telephone, TRW System 4000, Addressograph-Multigraph AMCAT, NCR

285/724, Datatrol cs 1400 or 1500; etc. Prices range from \$500 to \$1,500 (or \$10 to \$25/month rental).

The market is expected to grow rapidly as credit card sales gain increasing acceptance in all types of retail outlets, then fall off toward the end of the decade as POS systems provide credit checking capabilities in addition to their other functions. Development of inexpensive printing mechanisms to print credit card sales receipts could

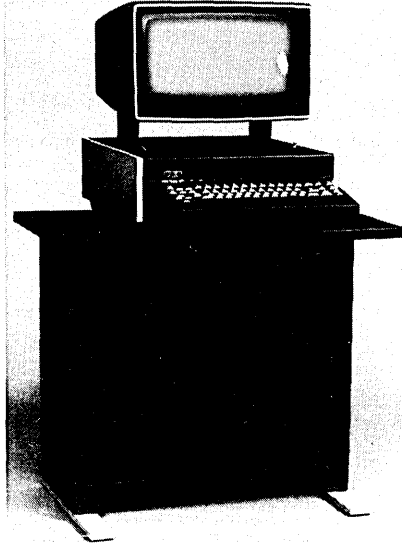

Teletype's Model 40 provides both visual and hardcopy output. Enhancements and improvements available should allow it to capture a large share of the market.

expand the terminals' functional capability and extend their lifetimes.

• **POS Systems and Terminals**—Electronic cash registers operating on-line to a controlling in-store computer and/or a centralized host system to assist sales persons' functions and capture sales data for cash, inventory, and sales analysis; frequently also incorporate price mark scanning devices. Includes such devices as: the NCR 255, 280; Singer MDTs, IBM 3650 and 3660 Series, Bunker Ramo ESIS System, DataChecker, and many others. Prices range from \$3,500 for simple electronic cash registers to \$10,000 for full function devices with scanners, price look-up, credit verification capability, etc.

The market is expected to grow strongly (over 25% per year) as increased source price marking gains acceptance and cost justification of total store systems becomes easier. Electronic Funds Transfer Systems would further spur growth and encourage the use of more versatile devices which can read credit/debit cards and print supplemental receipts.

Industrial Data Collection Terminals

• **Factory Data Terminals**—Terminals operated by factory workers to collect production control, inventory

and/or timekeeping information; normally incorporates badge reader, punched card reader and manually operated data entry mechanism (slides, dials or keys) as well as internally generated data; on-line to an in-plant controller and/or a centralized host system. Includes such devices as: the IBM 2970, Singer Manufacturing Information System, Data Pathing 2104, and the Control Data Transactor. Prices range from \$2,000 to \$4,000 for the terminal and its proportion of the controller.

The relatively mature market is expected to have a modest growth as factories gradually increase their automation efforts, but this may be spurred by a long overdue new product in this area by IBM.

The outlook

Overall, ADL predicts a growth in shipment values from 1975 to 1978 of about 14% per year for general-purpose devices and 25% per year for the special purpose devices. The value of the installed base should grow by 20% per year for general-purpose and 30% per year for the special purpose terminals. Any of these growth rates are undeniably impressive and help to explain the attraction of so many firms to the industry.

The major question facing the independent firms at this point is whether the projected decrease in their market share as a result of the aggressive efforts by IBM, the other computer systems manufacturers, and Teletype, will be enough to limit their chances for success in spite of the bullish market forecasts. Selection of the right strategy and dedication of sufficient resources to make it work is the key to determining who will succeed and who will fail in this new competitive environment. *

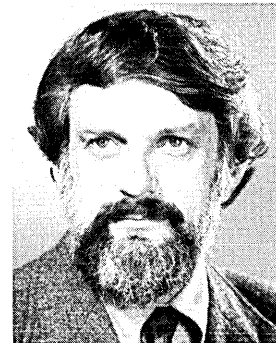

Mr. Salzman has been in the computing profession for 17 years in various programming, management, and consulting capacities. At Arthur D. Little, Inc. for the past eight years, he has specialized in the use of terminals in large systems and in terminal market and product planning studies.

Interactive Hardcopy Terminals

by Jackson W. Granholm

Computers and teletypewriters coexisted for some time before anyone thought to connect them. No one could have predicted the fruitfulness of that marriage, nor anticipated the number and variety of its offspring.

Man is a classifying animal. Among his other obnoxious traits, the human is apt to put things into tidy categories, label the categories and each item in them, and derive a sense of satisfaction from such activity.

We hope this survey of interactive hardcopy terminals does more, that it gives the reader an insight into the whole product category, and a means and direction with which to find his way to more specific and complete information.

It is certainly true that interactive hardcopy terminals have come of age in the world of computing. Clearly, this did not happen overnight. Univac I was designed with a most elegant set of keyboard and printing peripherals. In that machine of ancient days were all the visionary (for that time) foresights that we find embodied in today's equipment and applications. It may well have been justified that some considered the "Unityper" key to tape device and similar contraptions as a bit odd. But the Univac designers have been justified in their ability to see the world as it could be.

The capability of use of a computer by many remote customers has been with us a slightly shorter time. Teletype's devices have a long and useful history, but it was a long time after Univac before many people thought of connecting them remotely to computers.

In retrospect one may note that the world of potential early users of computers was largely a batch-oriented world. Many of those users were previously card equipment users. Card tabulating equipment, by the nature of its limited ability to concatenate operations, and its card-at-a-time orientation, imposes the point of view that a single user with a single problem involving minor amounts of "unusual" data is a most undesirable person, demanding sinful inefficiencies in system use.

Machines that strike a type slug on ink and paper as a key is pushed are

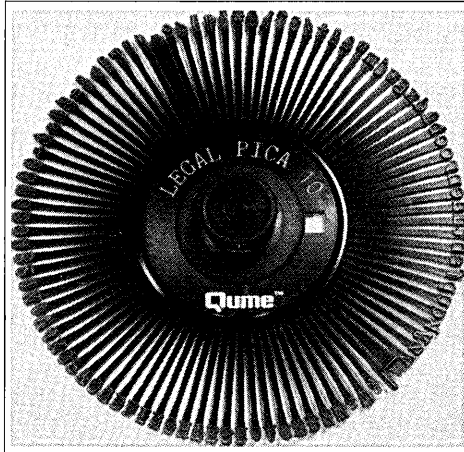

Daisywheel print mechanisms, which appear in many of the products in this survey, are built by Qume and Diablo/Xerox. Used in impact printers, the element is inexpensive, easy to replace, and makes a clean impression.

also not new, though at the time they were they constituted a welcome improvement over Gutenberg's method of picking up type with tweezers. However, one of the noticeable things about today's hardcopy terminals is the proliferation of inventiveness in mechanisms. Apparently electronics has not yet made the mechanical engineer obsolete, and things like the Qume and Diablo print wheels and the Interdata carousel would have seemed pretty far out to the inventors of the typewriter.

Printing mechanisms in terminals fall into two broad types. There are those that make use of a full and preformed character font. In contrast to these, the matrix printers have a single array of character elements (dot generators) and form each distinct character through logic imagery in contrast to a hard metal slug. Typically the preformed font printers may offer the capability for the user to change his font, while the matrix printers do not—at least not through physical alteration. The printers which form images by other than impact, by thermal means for instance, are typically found among the matrix printers such as the

Computer Transceiver 300 or NCR 260-2 KSR. These are, in general, characterized by the ability to make only a single original copy.

The other area in which change is evident in terminals is the trend toward the inclusion of memory and logic within the terminal. Increasingly we find the capability given to the user to make his terminal serve as whatever he would have it be. Alternatively, the cpu to which the terminal is connected can instruct it in its mode of operation on a *pro tem* basis. The IBM 3773 is an excellent example of such design.

One of the earliest serious and full-blown examples of this approach was found in the Burroughs TC 500. This machine originated in an effort to update the electromechanical capabilities of Burroughs accounting machines to the modern day of electronics. It made obvious sense for a company like Burroughs which has done rather well indeed with big business office "coffee-grinder" accounting machines.

The TC 500 enjoyed a rather impressive volume sale (booked by a Mr. MacDonald who earned further rewards subsequently by being elevated to Chairman of the firm) for use in the various branch offices of Barclay's Bank in London. This machine had virtually all the capabilities one might expect from an "intelligent" terminal, and it was the manifest prototype for the Burroughs TC (terminal computer) line of today.

What is included

In establishing the ground rules for our categorization we had, at first, to come up with some basic definitions. Our survey group includes devices which are interactive. That is, they accept input and produce output. While they may also be otherwise used, they do this via a communication line to some other, typically remote, location. In hewing to our definition of "interactive" we discarded, sometimes arbitrarily, devices which were input only or output only, but not both.

TERMINALS

The second part of our defining relates to "hardcopy." The devices in this survey are expected to produce paper. Volatile display terminals are excluded, though in some instances a crt may be included among the listing of peripherals to the terminal.

In other instances devices which are, in themselves, qualified for the survey, are purchased, augmented, repackaged, etc. by other vendors, and sold under a model number that, in itself, may be unique, while the device is not. This is particularly true of the products of Teletype Corp. We have tried to weed out duplicates, and to identify primary manufacturers only, but we may have goofed.

For instance, Diablo Systems of Hayward, Calif. is a subsidiary of Xerox. Both Diablo and Xerox Corp. market the terminal which Diablo builds. Since Diablo sales are primarily oem, but Xerox sells to end users, we have included the Xerox 3010 as the only entry in our product summary.

As another example, the RCA Service Co. does considerable business in terminals which are Teletype Corp. devices. You can lease from RCA a terminal which you can only buy from Teletype. Similarly, Randal Data Systems, Inc., of Torrance, Calif., distributes DEC and Diablo products, sometimes adding proprietary improvements, but Randal is not a terminal manufacturer. You may get exactly the lease deal you want from Randal, but you will not find them listed here among the terminal makers.

On the other hand, J. Beene Assoc. of Greensburg, Pa. builds a terminal that could have general purpose application, presumably, although its present users are all in the numeric control business. The Beene terminal does represent a buyer alternative, and is therefore included.

Reading the tables

In our summation we have tried to make each product entry as clear and self-readable as possible. This is difficult with a category which covers such a wide range of capabilities and prices (from under \$1,000 to over \$20,000). Frequently we have used the symbol "—" in an entry. Typically this means that no reply was given to this item. Alternatively and infrequently it may mean that we could not interpret a reply.

For items where the omission is "serious," that is, in our opinion makes the information considerably less complete than it ought to be, we have used the symbol "NG," for Not Given.

Information on model number, mechanism, speeds, program and plotting capability is given in the model and highlights portion at the top of each product column. The reader can quickly scan this, unless he needs the full cure for insomnia. After the final shakedown, we have counted 39 companies who have submitted 68 products to us.

Most people gave us the year of first shipment of their product, and some gave us the month. Many seemed reticent about the total number shipped. To those readers persnickety about business volumes, we suggest reading the company's annual report to stockholders.

We have used the abbreviations "cps" for characters per second and "bps" for bits per second in describing printing and transmission speeds. We interpret "lpi" as lines per inch in describing printing. Typically we have tried to abbreviate as little as possible throughout, and to make each entry stand alone. This has not always been possible.

Usually, where a terminal is described as "programmable" it is obvious how and why from the information supplied. In rare instances, machines are described as programmable, but it is not clear how they are so. Our

approach has been to give the submitter of information the benefit of the doubt unless there was a clear conflict of information.

Capability in plotting is a bit more difficult to nail down, and our questionnaire design was probably at fault in not being more specific on this item. In theory one could plot on any printer, using the period, asterisk, or any convenient character. For versatility in plotting it seems to us that a printer ought to have a bit more than this. We have looked for some evidence that the terminal had extra capabilities, such as bidirectional form feed, before we would give it the benefit of the plotting doubt.

In considering the printer characteristics one might note that typical spacing is ten to the inch horizontally (like a pica typewriter) and six lines to the inch vertically. There is some variation of this in various products, and the matrix printer has the inherent capability to print anything which can be represented within its mesh.

Form feeds include friction, which is typical of every typewriter, plus pin feed and tractor. Of these tractor is typically adjustable to form width. Some terminals offer all three feeds, some as options (costing more).

Easily changeable font for foundry-style type became a useful reality with the IBM Selectric. With many non-matrix terminal printers it is offered today, and it may be a versatility useful to some users. We find the time given for the user to change fonts may be a bit optimistic at the low end of the replies, and a bit discouraging at the high end, but we have not tried the changes ourselves.

Communication is the essential key that makes a terminal such. ASCII is by far the most common character code among the products listed here, though others are in sufficient abundance to fit anyone's needs. If a product does not list a specific interface, we suggest contacting the vendor directly as we suspect more interfaces are available than are listed.

Innovations galore

Here and there some interesting innovations cropped up among the things to be found on terminal keyboards. First prize may well go to the Logabax designers, who offer function keys which call forth preformed messages. The messages are, however, factory preformed.

The fully-programmable keyboard found in a few instances follows the early lead of the TC 500, mentioned previously. Fully implemented APL character sets are also offered by some vendors. This might relieve the previously-strained minds of some APL users who are not touch typists with

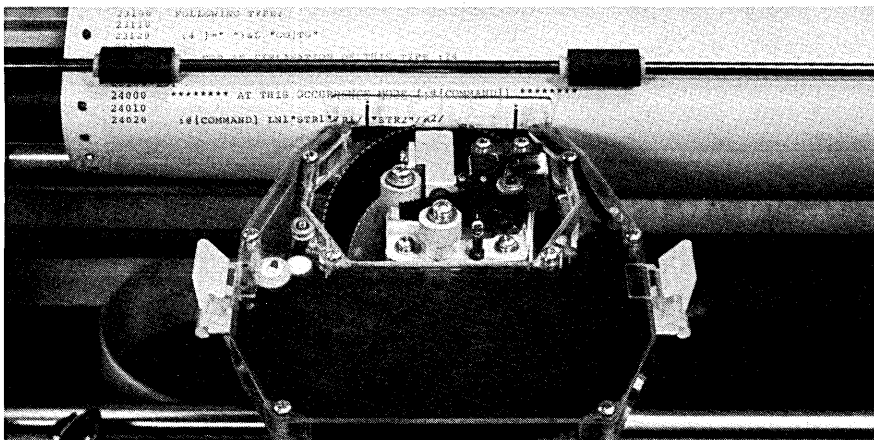

A good many better ways to put impressions on paper have been found since Gutenberg first began carving movable type. This mechanism, employing a type "Carousel" and ribbon bin, is from Interdata's Model 300.

INTERACTIVE HARDCOPY TERMINALS SURVEY

Manufacturer	Anderson Jacobson	Anderson Jacobson	Applied Computer Sys	Applied Computing	Bedford Computer
Model Highlights	630 1972 # shipped NG 5x8 matrix, thermal Print speeds 10, 15, 30cps Transmission speeds 110, 150, 300bps Character codes ASCII, APL Programmable no Plotting no	841 1971 # shipped NG Selectric ball, impact 15cps 150bps EBCDIC, Correspondence no no	3750 01/74 >200 shipped daisy wheel, impact 10, 15, 30cps selectable 110, 150, 300bps ASCII by mfr or by user standard	950 10/74 50 shipped 9x7 matrix, impact 120cps 110, 300, 1200bps ASCII by manufacturer yes	System 75 Model 0 new product daisy wheel, impact 30cps 110, 150, 300bps ASCII, (APL optional) no no
Printing	1 copy Print lines 140 cols Forms feed friction feed Font changes & cost — Special features horiz tab, lower case	6 copies 130/156 cols, 6 lines/ friction feed horiz tab, lower case	6 copies, 10/12 inches 158 cols, 6/8 lines/in pin, friction, tractor 10sec (\$10-\$13/font) horiz tab, split platen, lower case, bi-directional print	4 copies, 14 1/2 inches 132 cols, 6 lines/in tractor feed horiz & vert tab, bi-directional feed/print, 1/2-space, lower case	5 copies, 13.2 inches 132/158 cols, 6 lines/ friction, pin, tractor 30sec (\$10/font) 10 or 12 chars/inch, two color, lower case
Communications	asynch Compatibility — Electrical interfaces RS232C	asynch IBM 2741 RS232C	asynch RS232C, CCITT V24, full & 1/2-duplex —/1K buffer parity	asynch RS232C, current loop, parallel, full/1/2-dup —/320 char buffer parity	asynch RS232C, current loop, parallel, full/1/2-dup —/64 char buffer parity
Block & buffer sizes	—	—	—	—	—
Error checks	—	—	—	—	—
Special features	—	—	—	—	—
Keyboard Functions	—	—	tab, escape, control, backspace, line feed, repeat, delete	—	character and line edit functions
Memory & Peripherals	cassette	cassette	cassette, floppy disc (program load from either), RAM, ROM, PROM	numeric pad, 2K ROM	cassette
Pricing	mostly end user sales	mostly end user sales	mostly end user sales	mostly oem sales	mostly oem sales
Purchase	\$3,095	\$2,995	\$3,000 to \$3,995	\$3,150	\$3,595
Maintenance	—	—	\$25/month	—	\$25/month
1-year lease	\$119/month (inc maint)	\$101/month (inc maint)	\$150/month (3-year)	—	\$150/month (inc maint)

Manufacturer	Bedford Computer	J Beene Associates	Burroughs	Burroughs	Burroughs
Model Highlights	System 75 Model 11, V, X 06/74 270 shipped daisy wheel, impact 30cps (45 & 55 opt) 110 to 1200bps ASCII, (APL optional) by manufacturer graphics firmware	N/C-1 Datewriter 1965 >1,000 shipped cylinder, impact 10cps 110bps ASCII, EIA 244B by manufacturer no	TC 3600 — # shipped NG ball, impact 30cps 110-9600bps ASCII, EBCDIC by user no	TC 3800 — # shipped NG 5x7 matrix, impact 60cps 110-9600bps ASCII, EBCDIC by user no	TC 4000 05/75 # shipped NG 5x7 matrix, impact 60cps 75-9600bps ASCII no yes
Printing	5 copies, 13.2 inches 132/158 col, 6/8 lines pin, friction, tractor 30sec (\$10/font) 10 or 12 chars/inch, two color, bi-directional feed & print . . .	5 copies, 7.2 inches 72 col, 6 lines/inch pin or friction feed —	15 copies, 26 inches 255 cols, 6 lines/inch pin or friction feed 15 sec (\$NG) horiz & vert tab, split platen	6 copies, 26 inches 255 cols, 6 lines/inch pin or friction feed — horiz & vert tab, bi-directional print, split platen	6 copies, 16 1/2 inches 150 cols, 6 lines/inch pin feed — horiz & vert tab, 1/2-space, bi-direction forms feed
Communications	asynch Compatibility — Electrical interfaces RS232C, current loop, full & 1/2-duplex —/180 char buffer parity auto answer, ACK-NAK optional	asynch RS232C, current loop, parallel, full/1/2-dup —	asynch or synch RS232C, 1/2-duplex	asynch or synch RS232C, 1/2-duplex	asynch or synch RS232C, 1/2-duplex
Block & buffer sizes	—	—	4K chars/4K buffer parity, LRCC, CRCC direct poll/address, auto answer, concat.	4K chars/4K buffer parity, LRCC, CRCC direct poll/address, auto answer, concat.	256-1536 char/1536 char parity, LRCC direct poll/address
Error checks	—	—	—	—	—
Special features	—	—	—	—	—
Keyboard Functions	APL keyboard (opt), character and line editing, lower case . . .	edit and code conver- sion	programmable functions, numeric pad	programmable	communications and peripheral control
Memory & Peripherals	cassette, 2K PROM	paper tape, numeric pad, 4K ROM, 16K PROM, 4K RAM	cassette, tape, cards, floppy disc, display, ppt. up to 64K memory	cassette, tape, cards, paper tape, displays, up to 64K memory . . .	cassette, floppy disc, 256-char display, 2K ROM
Pricing	mostly end user sales	mostly end user sales	mostly end user sales	mostly end user sales	mostly end user sales
Purchase	\$4,295 to \$5,400	\$2,250 to \$6,000	\$16,500 to \$18,000	\$18,500 to \$20,000	\$4,945 to \$9,495
Maintenance	\$35/month	—	—	—	—
1-year lease	\$150 to \$165/month	—	\$515 to \$565/month	\$580 to \$625/month	\$164 to \$295/month

INTERACTIVE HARDCOPY TERMINALS SURVEY

Manufacturer	Burroughs	Centronics	Centronics	Comdata	Compro
Model Highlights	TC 5100 09/75 # shipped NG 5x7 matrix, impact 60cps 75-9600bps ASCII, EBCDIC by user no	308 03/75 # shipped NG 5x7 matrix, impact 165cps to 9600bps ASCII no no	508 03/75 # shipped NG 5x7 matrix, impact 165cps to 9600bps ASCII no no	933 05/74 # shipped NG wheel, impact 10, 15, 30cps 110, 150, 300bps ASCII, EBCDIC, APL no yes	6000 — # shipped NG proprietary, impact 10, 15, 30cps 110, 150, 300bps ASCII, EBCDIC, APL by manufacturer yes
Printing	6 copies, 16 1/2 inches 150 cols, 6 lines/inch pin feed — horiz & vert tab	4 copies, 9 1/2 inches 80 cols, 6 lines/inch pin feed — horiz & vert tab, 1/2-space, lower case, 9x7 matrix	4 copies, 14 1/2 inches 132 cols, 6 lines/inch pin feed — horiz & vert tab, 1/2-space, lower case, 9x7 matrix	8 copies, 14 1/2 inches 132/158 col, 6/8 lines/ pin, friction, tractor 15sec (\$15/font) horiz & vert tab, 1/2-space, lower case, bi-direct feed & print	6 copies, 13.2 inches 132 cols, 6 lines/inch pin or friction feed 20sec (\$25/font) horiz & vert tab, 1/2-space, lower case, bi-direct feed & print
Communications	asynch or synch BDLC RS232C, 1/2-duplex	asynch RS232C, current loop, parallel, full/1/2-dup —/120 char buffer parity auto answer	asynch RS232C, current loop, parallel, full/1/2-dup —/120 char buffer parity auto answer	asynch RS232C, CCITT V24, loop, full/1/2-duplex —/128 char buffer parity direct poll/address, auto answer	asynch RS232C, current loop, full & 1/2-duplex — parity —
Keyboard Functions	programmable functions, numeric pad	—	—	repeat, break, numeric pad	—
Memory & Peripherals	cassette, floppy disc, (either loads program), display, 28K RAM	cassette, numeric pad	cassette, numeric pad	cassette, paper tape, floppy disc	cassette, paper tape, floppy disc, numeric pad, 2K PROM
Pricing	mostly end user sales Purchase \$13,900 to \$25,000 Maintenance — 1-year lease \$430 to \$780/month	mostly end user sales Purchase \$3,745 Maintenance \$32/month 1-year lease \$183/month (2-year)	mostly end user sales Purchase \$4,745 Maintenance \$34/month 1-year lease \$232/month (2-year)	mostly end user sales Purchase \$3,300 to \$5,970 Maintenance — 1-year lease \$115/month (4-year)	mostly oem sales Purchase \$3,200 to \$5,200 Maintenance \$20/month (24 hour) 1-year lease \$350/month

Manufacturer	Computer Devices	Computer Devices	Computer Transceiver	Computer Transceiver	Data Access Systems
Model Highlights	1030 & Miniterm 11/69 >4,000 shipped 5x7 matrix, thermal 10, 15, 30cps 110, 150, 300bps ASCII, EBCDIC, Corres. no no	1132 — >400 shipped 5x7 matrix, thermal 10, 15, 30cps 110, 150, 300bps ASCII, EBCDIC, Corres. no no	Execuport 300 1968 # shipped NG thermal 10, 15, 30cps 110, 150, 300bps ASCII, EBCDIC no no	Execuport 1200 1968 # shipped NG impact 10, 15, 30, 60, 120cps 110 to 1200bps ASCII, EBCDIC no no	300 09/74 295 shipped wheel, impact 10, 15, 30cps 110, 150, 300bps ASCII, EBCDIC, Baudot by user yes
Printing	1 copy, 8.5 inches 80 cols, 6 lines/inch friction feed — lower case	1 copy, 8.5 inches 132 cols, 6 lines/inch friction — lower case	1 copy 50 cols, 6 lines/inch friction feed — —	6 copies 140 cols, 6 lines/inch pin feed — —	6 copies, 14 1/2 inches 156 cols, 6/8 lines/in pin, friction, tractor 5sec (\$9.50/font) horiz & vert tab, low- er case, bi-direct feed
Communications	asynch — RS232C, CCITT V24, loop, parallel, full/1/2-dup — parity —	asynch — RS232C, CCITT V24, loop, parallel, full/1/2-dup — parity —	asynch — RS232C, CCITT V24, loop, parallel, full/1/2-dup — parity —	asynch — RS232C, CCITT V24, loop, parallel, full/1/2-dup — parity —	asynch — RS232C, current loop, full & 1/2-duplex —/128 char buffer parity —
Keyboard Functions	—	—	—	—	—
Memory & Peripherals	cassette, numeric pad, paper tape, 192 char ROM	cassette, numeric pad, paper tape, 192 char ROM	cassette, numeric pad, paper tape	cassette, numeric pad, paper tape	cassette, 128 char ROM, 128 char PROM
Pricing	mostly end user sales Purchase \$1,750 to \$2,825 Maintenance \$20/month 1-year lease \$125/month	mostly end user sales Purchase \$3,900 to \$4,500 Maintenance — 1-year lease —	mostly end user sales Purchase \$2,795 Maintenance \$20/month 1-year lease \$122/month (inc maint)	mostly end user sales Purchase \$4,995 Maintenance — 1-year lease —	mostly end user sales Purchase \$4,200 to \$5,000 Maintenance \$30/month 1-year lease \$190/month

INTERACTIVE HARDCOPY TERMINALS SURVEY

Manufacturer	Dataproducts-Stelma	Data Terminale	Di-An Controls	Digital Equipment	Extel
Model Highlights	PC 8110 Portacom 1970 # shipped NG impact 10cps 110, 150, 300bps ASCII no no	300 Series & HyWriter 1973 >2,000 shipped daisy wheel, impact 10, 15, 30cps 110, 150, 300bps ASCII, EBCDIC, Baudot by manufacturer CalComp compatible	9000 1972 1,000 shipped 5x7 matrix, impact 10, 15, 30, 60cps 110, 150, 300, 600bps ASCII no no	LA36-DA, Decwriter II 11/74 15,000 shipped 7x7 matrix, impact 30cps 110, 150, 300bps ASCII no no	A & B Series 1970 40,000 shipped 5x7 matrix, impact 10, 15, 30cps 110, 150, 300bps ASCII, CCITT #2, Baudot by mfr and by user no
Printing	3 copies 80 cols, 6 lines/inch pin or friction feed — —	6 copies, 14 1/4 inches 158 cols, 6/8 lines/in pin, friction, tractor 15sec (\$9-\$13/font) horiz & vert tab, bi- directional feed & print, lower case . . .	6 copies, 13.2 inches 132 cols, 6 lines/inch pin feed — horiz & vert tab, low- er case	6 copies, 14 1/4 inches 132 cols, 6 lines/inch tractor feed switch selectable (\$NG) horiz & vert tab, low- er case	3 copies, 8 1/2 inches 80 cols, 4 1/4 lines/ pin or friction feed 1sec (no charge) lower case, 1/2-space
Communications	asynch — RS232C, full & 1/2-dup- lex — parity —	asynch — RS232C, current loop, parallel, full/1/2-dup 4K chars/128 char parity auto answer, other character codes	asynch — RS232C, CCITT V24, loop, full & 1/2-duplex —/64 char buffer parity —	asynch — RS232C, CCITT V24, loop, full/1/2-duplex —/16 char buffer parity direct poll/address, auto answer	asynch — RS232C, CCITT V24, loop, parallel, full/1/2-dup —/128 char buffer parity direct poll/address, auto answer
Keyboard Functions	—	editing	view key	—	memory edit, call new line, figure insert, others
Memory & Peripherals	—	floppy disc, numeric pad, 3K ROM	cassette, numeric pad	numeric pad	paper tape, 6K ROM, 2K PROM, 10K RAM
Pricing	mostly end user sales \$1,495 \$18/month —	mostly end user sales \$3,690 to \$4,500 \$25/month \$160/month	mostly end user sales \$1,850 to \$2,400 — —	mostly oem sales \$1,250 — —	mostly end user sales \$1,750 to \$4,000 \$32/month \$77/month (inc maint)

Manufacturer	Facit-Addo	Facit-Addo	Gencom Systems	General Electric	General Electric
Model Highlights	4553 1972 # shipped NG 5x7 matrix, impact 15cps 150bps ASCII no no	4554 1972 # shipped NG 5x7 matrix, impact 60cps 600bps ASCII no no	300 Series 09/73 1,500 shipped daisy wheel, impact 10, 15, 30, 60cps 110, 150, 300, 600bps ASCII, EBCDIC, Corres. by mfr and by user yes	Terminet 30 1975 1,000 shipped 9x7 matrix, impact 10, 20, 30cps 110 to 1200bps ASCII, others by manufacturer no	Terminet 300 1969 50,000 shipped character belt, impact 10, 15, 30cps 110 to 1200bps ASCII, others by manufacturer no
Printing	4 copies 80 cols, 10 lines/inch pin feed — —	4 copies 80 cols, 10 lines/inch pin feed — —	6 copies, 13.2 inches 132/158 col, 6/8 lines/ pin, friction, tractor 30sec (\$8.50/font) horiz & vert tab, bi- directional feed & print, lower case . . .	4 copies, 8 inches 80/132 col, 6 lines/in pin, friction, tractor — vert tab, lower case, compact print	6 copies, 12 inches 120 cols, 6 lines/inch pin, friction, tractor 60sec (99¢/font) horiz & vert tab, two color, lower case, split platen
Communications	asynch — RS232C, CCITT V24, current loop, parallel — —	asynch — RS232C, CCITT V24, current loop, parallel — —	asynch and synch programmable RS232C, current loop, parallel, full/1/2-dup programmable/256 char parity, programmable direct poll/address, others programmable	asynch or synch — RS232C, current loop, parallel, full/1/2-dup — parity, others auto answer	asynch or synch — RS232C, current loop, parallel, full/1/2-dup — parity, others direct poll/address, auto answer, TWX, DDD
Keyboard Functions	—	—	—	interrupt, transparent feed, space & control functions	interrupt, transparent feed, space & control functions
Memory & Peripherals	—	—	cassette, floppy disc, paper tape, 2K ROM, 1K char RAM, 4K PROM	cassette, numeric pad, commo controller, ppt, up to 16K memory	cassette, numeric pad, commo controller, ppt, up to 16K memory
Pricing	mostly oem sales \$995 — —	mostly oem sales \$2,295 — —	mostly end user sales \$3,825 to \$4,500 \$25/month \$185/month (inc maint)	mostly oem sales \$1,410 to \$4,513 — —	mostly oem sales \$2,263 (RO) to \$4,055 — \$115/month (inc maint)

INTERACTIVE HARDCOPY TERMINALS SURVEY

Manufacturer	General Electric	Harris Data	Interdata	IBM	IBM
Model Highlights	Terminet 1200 1972 15,000 shipped character belt, impact 110 to 120cps 110 to 1200bps ASCII, others by manufacturer no	1030 & 1035 1969 4,000 shipped Typesphere, impact 15cps 134.5bps EBCDIC, Correspondence no no	300 07/75 # shipped NG Carousel cup, impact 10, 15, 30, 40cps 110, 150, 300bps ASCII no 4800 points/sq inch	2740 Model 1 & 2741 1964 # shipped NG Selectric ball, impact 14.5cps 134.5bps EBCDIC no no	2740 Model 2 1964 # shipped NG Selectric ball, impact 14.5cps 134.5, 600bps EBCDIC no no
Printing	6 copies, 12 inches 120 cols, 6 lines/inch pin, friction, tractor 60sec (99¢/font) horiz & vert tab, lower case	6 copies, 13 inches 132 cols, 6 lines/inch pin or friction feed 5sec (\$NG) horiz tab, lower case	5 copies, 13.2 inches 128 cols, 6 lines/inch friction or tractor 10sec (\$NG) horiz & vert tab, bi-directional feed, lower case, 1/2-space	6 copies, 13.5 inches 132 cols, 6/8 lines/inch pin or friction feed 2sec (\$9/font) horiz & vert tab, lower case	6 copies, 13.5 inches 132 cols, 6/8 lines/inch pin or friction feed 2sec (\$9/font) horiz & vert tab, lower case
Communications	asynch or synch — RS232C, current loop, parallel, full/1/2-dup — parity, others direct poll/address, auto answer, 2-modem	asynch IBM 2741 RS232C, full & 1/2-dup — parity auto answer	asynch — RS232C, current loop, full & 1/2-duplex —/128 char buffer parity auto transmission of identifier	synch IBM 3767 RS232C, CCITT V24 1/2-duplex — LRCC auto answer	synch IBM 3767 RS232C, CCITT V24, 1/2-duplex 224 or 440 chars each LRCC auto answer
Keyboard Functions	interrupt, transparent feed, space & control functions	repeat, editing	electronic format control, break, repeat, numeric pad	—	character edit
Memory & Peripherals	cassette, numeric pad, commo controller, ppt, up to 16K memory	cassette	cassette, paper tape reader	—	—
Pricing	mostly oem sales Purchase \$2,298 (RO) to \$5,300 Maintenance — 1-year lease \$144/month (inc maint)	mostly end user sales Purchase \$1,600 to \$1,800 Maintenance \$30/month 1-year lease \$96/month	mostly oem sales Purchase \$2,450 to \$3,800 Maintenance — 1-year lease —	mostly end user sales Purchase \$4,000 to \$7,000 Maintenance \$23/month 1-year lease \$95/month	mostly end user sales Purchase \$4,000 to \$7,000 Maintenance \$28/month 1-year lease \$210/month

Manufacturer	IBM	IBM	IBM	Logabax	Logabax
Model Highlights	3767 02/75 # shipped NG 7x9 matrix, impact 40, 80, 120cps 134.5 to 2400bps EBCDIC no no	3771 06/75 # shipped NG 7x9 matrix, impact 40, 80, 120cps 1200 to 4800bps EBCDIC no no	3773 06/75 # shipped NG 7x9 matrix, impact 40, 80, 120cps 1200 to 4800bps EBCDIC by mfr and by user yes	LX 180/57 1972 2,500 shipped 7x7 matrix, impact 60, 120, 240cps 600, 1200, 2400bps EBCDIC by manufacturer no	LX 180/KSR 1972 1,800 shipped 7x7 matrix, impact 10, 15, 60, 120, 240cps 110 to 2400bps ASCII no
Printing	5 copies, 13 1/2 inches 132 cols, 6/8 lines/inch pin, friction, tractor 1sec (no charge) horiz & vert tab, bi-directional printing, lower case	6 copies, 13 1/2 inches 132 cols, 6 lines/inch friction or tractor — horiz & vert tab, bi-directional printing, lower case	6 copies, 13 1/2 inches 132 cols, 6 lines/inch friction or tractor — horiz & vert tab, bi-directional printing, lower case	5 copies, 17 inches 132/158/220 col, 6lpi pin feed — horiz & vert tab, lower case, split platen	5 copies, 17 inches 132/158/220 col, 6lpi pin feed — horiz & vert tab, lower case, split platen
Communications	asynch start-stop, SDLC RS232C, CCITT V24, full & 1/2-duplex —/1K buffer LRCC direct poll/address, auto answer	synch BSC, SDLC RS232C, CCITT V24, full & 1/2-duplex 256 chars/two 256 char LRCC auto answer	synch BSC, SDLC RS232C, CCITT V24, full & 1/2-duplex 256 char/two 256 char LRCC auto answer	asynch IBM 2740 II RS232C, CCITT V24 — 256 chars/two 256 char parity, LRCC, VRC direct poll/address, hub go-ahead polling	asynch — RS232C, CCITT V24, loop, full & 1/2-duplex —/256 char buffer parity auto answer
Keyboard Functions	buffer line edit	buffer line edit	buffer line edit, arith logic functions, numeric pad	ten recorded messages up to 16 chars each	—
Memory & Peripherals	—	card reader & punch	floppy disc, 12K RAM, program loaded from host cpu	only for messages	cassette, numeric pad
Pricing	mostly end users Purchase \$4,000 to \$7,000 Maintenance \$35/month 1-year lease \$180/month	mostly end user sales Purchase \$17,800 to \$21,640 Maintenance \$49/month 1-year lease \$270/month	mostly end user sales Purchase \$12,600 to \$16,600 Maintenance \$60/month 1-year lease \$306/month	mostly end user sales Purchase \$6,200 to \$8,000 Maintenance \$40/month 1-year lease \$199/month (inc maint)	mostly end user sales Purchase \$4,200 to \$4,850 Maintenance \$40/month 1-year lease \$170/month (inc maint)

INTERACTIVE HARDCOPY TERMINALS SURVEY

Manufacturer	Memorex	Memorex	Memorex	MI ² Data Systems	NCR
Model Highlights	1240 1971 # shipped NG Cartridge belt, impact Print speeds 10, 15, 30, 60, 120cps Transmission speeds 110 to 1200bps Character codes ASCII, APL Programmable Plotting	1242 1972 # shipped NG Cartridge belt, impact 30, 60, 120, 240cps 1200 to 9600bps ASCII no no	1280 1971 # shipped NG Cartridge belt, impact 10 to 120cps 110 to 1200bps ASCII no no	120MSR — 5x7 matrix, impact 30, 110, 240cps 110, 150, 300, 600bps ASCII, EBCDIC by user yes	260-2 KSR 1971 2,760 shipped 5x7 matrix, thermal 10, 30cps 110, 300bps ASCII no no
Printing	6 copies, 14 1/4 inch 120 cols, 6 lines/in pin or tractor feed 2 min (\$NG) horiz & vert tab, lower case	6 copies, 14 1/4 inch 120 cols, 6 lines/in pin or tractor feed — horiz & vert tab, lower case	6 copies, 14 1/4 inch 120 cols, 6 lines/in pin or tractor feed 2 min (\$NG) horiz & vert tab, lower case	6 copies, 13.2 inches 132 cols, 6 lines/in tractor feed — horiz & vert tab, char-by-char print, two-color, expanded chars	1 copy, 8 inches 80 cols, 3/6 lines/in friction feed — lower case
Communications	asynch TWX RS232C, (dual), parallel, full/1/2-duplex — parity, LRCC auto answer	asynch and ext. clock — RS232C. 1/2-duplex — 256 or 512 chars each parity, LRCC direct poll/address	asynch TWX RS232C (dual), parallel, full/1/2-duplex — parity, LRCC auto answer	asynch SDLC RS232C, current loop, parallel, full/1/2-dup 132 chars/264 chars parity, LRCC —	asynch — RS232C, current loop, full & 1/2-duplex — parity auto transmission of identifier code
Keyboard Functions	convert to upper case from lower case transmission	convert to upper case from lower case transmission	convert to upper case from lower case transmission	—	—
Memory & Peripherals	numeric pad, crt attachment	cassette, numeric pad, crt attachment	cassette, numeric pad, crt attachment	tape cartridge, 4K ROM, 4K PROM, 15K RAM	—
Pricing	mostly end user sales Purchase \$2,500 to \$3,000 Maintenance — 1-year lease \$175/month	mostly end user sales Purchase \$3,300 to \$4,000 Maintenance — 1-year lease \$220/month	mostly end user sales Purchase \$3,500 to \$5,000 Maintenance — 1-year lease \$250/month	mostly oem sales Purchase \$2,200 (RO) to \$5,000 Maintenance — 1-year lease —	mostly end user sales Purchase \$2,320 Maintenance \$11/month 1-year lease \$95/month

Manufacturer	NCR	NCR	SCM Kleinschmidt	Scope Data	Sidereal
Model Highlights	260-5 Portable KSR 1974 1,350 shipped 5x7 matrix, thermal 10, 30cps 110, 300bps ASCII no no	260-6 ASR 1973 1,539 shipped 5x7 matrix, thermal 10, 15, 20, 30cps 110, 150, 200, 300bps ASCII no no	7300 1972 # shipped NG drum, impact 10, 15, 30cps 50 to 300bps ASCII, Baudot no no	200 & 200 X/L 1973 1,000 shipped 7x9 matrix, electro. 10 to 240cps 110 to 2400bps ASCII, Baudot, APL no no	X-120/8 new product 7x9 matrix, impact 10, 15, 30, 60, 120cps to 9600bps ASCII, APL, Baudot by mfr or by user yes
Printing	1 copy, 8 inches 80 cols, 3/6 lines/in friction feed — lower case	1 copy, 8 inches 80 cols, 3/6 lines/in friction feed — lower case	6 copies, 8 inches 80 cols, 10 lines/in pin or friction feed — horiz & vert tab	1 copy, 8 inches 132 cols, 6 lines/in friction feed 1sec (\$280/font) lower case	5 copies, 8 1/2 inches 80 cols, 5/6 lines/in tractor feed switchable (\$25/font) horiz & vert tab, bi-directional print, 132-col condensed
Communications	asynch — RS232C, current loop, full & 1/2-duplex — parity auto answer, auto transmission of identifier	asynch — RS232C, current loop, full & 1/2-duplex two 256 char/256 char parity, CRCC auto answer, operator lead-through, others	asynch — RS232C, current loop, parallel, full/1/2-dup —/16 chars parity direct poll/address	asynch — RS232C, current loop, parallel, full/1/2-dup —/256 char buffer parity —	asynch or synch programmable RS232C, CCITT V24, loop, full & 1/2-duplex 4K chars/32K buffer parity, LRCC, CRCC direct poll/address, auto answer
Keyboard Functions	—	buffer & cassette control, editing	—	break, repeat	12 programmable functions, editing
Memory & Peripherals	—	cassette	paper tape	—	cassette, numeric pad, floppy disc
Pricing	mostly end user sales Purchase \$2,795 Maintenance \$16/month 1-year lease \$122/month	mostly end user sales Purchase \$3,295 Maintenance \$26/month 1-year lease \$150/month	mostly oem sales Purchase \$4,200 to \$6,000 Maintenance — 1-year lease —	mostly end user sales Purchase \$1,895 (RO) to \$2,800 Maintenance \$20/month (one shift) 1-year lease —	mostly oem sales Purchase \$1,400 to \$2,100 Maintenance \$24/month 1-year lease —

INTERACTIVE HARDCOPY TERMINALS SURVEY

Manufacturer	Sidereal	Singer Bus Mach	Tally	Teletype	Teletype
Model Highlights	X-120Z	M-30 (Model 74)	1000	28 KSR	28 ASR
1st ship/# shipped	09/75 # shipped NG	1971 2,500 shipped	new product	1952 see 28 ASR	1952 300,000 shipped
Print mechanism	7x9 matrix, impact	5x7 matrix, impact	9x7 matrix, impact	typebox, impact	typebox, impact
Print speeds	10, 15, 30, 60, 120cps	30cps	120cps	10cps	10cps
Transmission speeds	to 9600bps	110, 150, 300bps	up to 1800bps	74.2bps	74.2bps
Character codes	ASCII, APL, Baudot	ASCII	ASCII	Baudot	Baudot
Programmable	by mfr or by user	no	by manufacturer	no	no
Plotting	yes	no	no	no	no
Printing					
Print lines	5 copies, 14 1/4 inches	6 copies, 13.2 inches	5 copies, 13.2 inches	8 copies, 8 1/2 inches	8 copies, 8 1/2 inches
Forms feed	132 cols, 5/6 lines/in tractor feed	80/132 cols, 6 lines/in pin or friction feed	132 cols, 6 lines/inch pin feed	72/74 cols, 6 lines/in pin or friction feed	72/74 cols, 6 lines/in pin or friction feed
Font changes & cost	switchable (\$25/font)	—	—	20sec (\$41.70/font)	20sec (\$41.70/font)
Special features	horiz & vert tab, bi-directional print, 230-col condensed	horiz & vert tab, lower case	horiz & vert tab, bi-directional print, 1/2-space print	horiz & vert tab	horiz & vert tab
Communications					
Compatibility	asynch or synch programmable	asynch	—	asynch	asynch
Electrical interfaces	RS232C, CCITT V24, loop, full & 1/2-duplex	RS232C, current loop, parallel, full & 1/2-dup	RS232C, CCITT V24	CCITT #2, loop, full & 1/2-duplex	CCITT #2, loop, full & 1/2-duplex
Block & buffer sizes	4K chars/32K buffer	—/40 char buffer	—	—	—
Error checks	parity, LRCC, CRCC	parity	—	—	—
Special features	direct poll/address, auto answer	auto answer	—	direct poll/address	direct poll/address
Keyboard Functions	12 programmable functions, editing	—	—	local controls for printer, break	local controls for printer, break
Memory & Peripherals	cassette, numeric pad, floppy disc	numeric pad	PROM	—	paper tape
Pricing					
Purchase	mostly oem sales \$1,600 to \$2,200	mostly end user sales \$1,779 to \$2,700	mostly end user sales \$2,775	mostly oem sales \$1,818 to \$2,071	mostly oem sales \$3,062 to \$4,987
Maintenance	\$27/month	\$32/month	—	\$21 to \$27/month	\$25 to \$31/month
1-year lease	\$95/month	\$125/month	—	—	—

Manufacturer	Teletype	Teletype	Teletype	Teletype	Teletype
Model Highlights	32 KSR	32 ASR	33 KSR	33 ASR	35 KSR
1st ship/# shipped	09/62 # shipped NG	09/62 # shipped NG	09/62 see 33 ASR	09/62 <500,000 shipped	10/62 see 35 ASR
Print mechanism	typewheel, impact	typewheel, impact	typewheel, impact	typewheel, impact	typewheel, impact
Print speeds	10cps	10cps	10cps	10cps	10cps
Transmission speeds	75bps	75bps	110bps	110bps	110bps
Character codes	Baudot	Baudot	ASCII	ASCII	ASCII
Programmable	no	no	no	no	no
Plotting	no	no	no	no	no
Printing					
Print lines	3 copies, 8 1/2 inches	3 copies, 8 1/2 inches	3 copies, 8 1/2 inches	3 copies, 8 1/2 inches	8 copies, 8 1/2 inches
Forms feed	72 cols, 6 lines/in pin or friction feed	72 cols, 6 lines/in pin or friction feed	72 cols, 6 lines/inch pin or friction feed	72/74 cols, 6 lines/in pin or friction feed	72/74 cols, 6 lines/in pin or friction feed
Font changes & cost	60sec (\$7.55/font)	60sec (\$7.55/font)	60sec (\$7.55/font)	60sec (\$7.55/font)	20sec (\$41.70/font)
Special features	—	—	—	—	horiz & vert tab
Communications					
Compatibility	asynch	asynch	asynch	asynch	asynch
Electrical interfaces	CCITT #2, loop, full/1/2-dup	CCITT #2, loop, full/1/2-dup	RS232C, loop, full & 1/2-duplex	RS232C, loop, full & 1/2-duplex	RS232C, CCITT V24, loop, full & 1/2-duplex
Block & buffer sizes	—	—	—	—	—
Error checks	—	—	parity	parity	parity
Special features	—	—	direct poll/address, auto answer	direct poll/address, auto answer	direct poll/address, auto answer
Keyboard Functions	local controls for printer, break	local controls for printer, break	local controls for printer, break	local controls for printer, break	local controls for printer, break
Memory & Peripherals	—	paper tape	—	paper tape, mag tape	—
Pricing					
Purchase	mostly oem sales \$731 to \$765	mostly oem sales \$894 to \$1,106	mostly oem sales \$693 to \$1,056	mostly oem sales \$938 to \$1,363	mostly oem sales \$2,102 to \$2,988
Maintenance	\$21 to \$30/month	\$24 to \$33/month	\$21 to \$30/month	\$24 to \$33/month	\$21 to \$27/month
1-year lease	—	—	—	—	—

INTERACTIVE HARDCOPY TERMINALS SURVEY

Manufacturer	Teletype	Texas Instruments	Texas Instruments	Texas Instruments	Texas Instruments
Model Highlights	35 ASR 10/62 130,000 shipped typebox, impact Print speeds 10cps Transmission speeds 110bps Character codes ASCII Programmable no Plotting no	732 ASR/KSR 1972 # shipped NG 5x7 matrix, thermal 6,67, 10, 13.3cps 50, 75, 100bps Baudot no no	733 ASR/KSR 1972 # shipped NG 5x7 matrix, thermal 10, 15, 30cps 110, 150, 300, 1200bps ASCII no no	735 Portable 1974 # shipped NG 5x7 matrix, thermal 10, 15, 30cps 110, 150, 300bps ASCII no no	742 1974 # shipped NG 5x7 matrix, thermal 10, 15, 30cps 110, 150, 300, 1200bps ASCII by user no
Printing	8 copies, 8½ inches 72/74 cols, 6/3 lines/in pin or friction feed 20sec (\$41.70/font) horiz & vert tab	1 copy, 8 inches 80 cols, 3/6 lines/in friction feed — —	1 copy, 8 inches 80 cols, 3/6 lines/in friction feed — lower case	1 copy, 8 inches 80 cols, 3/6 lines/in friction feed — lower case	1 copy, 8 inches 80 cols, 3/6 lines/in friction feed — lower case
Communications	asynch — RS232C, CCITT V24, loop, full & ½-duplex — parity direct poll/address, auto answer	asynch — RS232C, current loop, full & ½-duplex —/86 char buffer — answerback memory	asynch — RS232C, current loop, full & ½-duplex —/86 char buffer — auto answer, answer- back memory	asynch — RS232C, full & ½-dup — — —	asynch — RS232C, ½-duplex — 425 chars/86 chars parity, LRCC direct poll/address, auto answer
Keyboard Functions	local controls for printer, break	move tape, editing	move tape, editing	—	home, rubout, break, move tape, numeric pad
Memory & Peripherals	paper tape, mag tape	cassette	cassette	connection only	cassette, 10K ROM, 4K RAM
Pricing	mostly oem sales Purchase \$3,530 to \$4,967 Maintenance \$25 to \$31/month 1-year lease —	mostly end user sales Purchase \$1,575 to \$3,095 Maintenance \$15 to \$30/month 1-year lease \$90 to \$150 (inc maint)	mostly end user sales Purchase \$1,500 to \$4,000 Maintenance \$15 to \$30/month 1-year lease \$85 to \$145 (inc maint)	mostly end user sales Purchase \$2,595 to \$2,620 Maintenance \$25/month 1-year lease \$135/month (inc maint)	mostly end user sales Purchase \$4,925 to \$6,015 Maintenance \$35/month 1-year lease \$240/month (inc maint)

Manufacturer	Trendata	Tycom Systems	Univac	Univac	Xerox
Model Highlights	4000 12/74 300 shipped daisy wheel, impact Print speeds 10, 15, 30cps Transmission speeds 110, 150, 300bps Character codes ASCII, EBCDIC Programmable function keys only Plotting yes	KSR-38 — 1,000 shipped ball, impact 10, 15cps 110, 150, 2400bps ASCII no no	DCT 500 07/70 # shipped NG wheel, impact not given 110, 150, 300bps ASCII no no	DCT 1000 05/71 # shipped NG wheel, impact not given 110 to 4800bps ASCII no no	3010 06/75 # shipped NG wheel, impact 10, 15, 30cps 110, 150, 300bps ASCII, APL by manufacturer 2880 points/sq inch
Printing	5 copies, 13 inches 156 cols, 6/8 lines/in pin, friction, tractor 20sec (\$13/font) horiz & vert tab, low- er case, ½-space, bi- directional form feed	10 copies 156 cols pin or friction feed 2sec (\$25/font) horiz tab, lower case, ½-space	6 copies 132 cols, 6 lines/in pin feed — —	6 copies 132 cols, 6 lines/in pin feed — horiz tab	6 copies, 13.2 inches 132/158 cols, 6/8lpi pin, friction, tractor 20sec (\$10-\$14/font) horiz & vert tab, bi- directional feed & print, lower case . . .
Communications	asynch SDLC RS232C, CCITT V24, loop, full & ½-duplex — parity auto answer	asynch — RS232C, CCITT V24, loop, parallel, full/½-dup . . — parity —	asynch — RS232C, CCITT V24, full-duplex variable block/— buff parity direct poll/address, auto answer	synch or asynch — RS232C, CCITT V24 — 160 chars each parity, LRCC direct poll/address, auto answer	asynch — RS232C, full & ½-dup — —/768 char buffer parity —
Keyboard Functions	3 programmable function keys	—	—	horiz tab	repeat, numeric pad
Memory & Peripherals	cassette, numeric pad	cassette, floppy disc, paper tape, mag card, crt	cassette, paper tape	paper tape, card read- er, punch	—
Pricing	mostly end user sales Purchase \$5,150 Maintenance \$30/month 1-year lease \$180/month	mostly end user sales Purchase \$2,350 Maintenance \$25/month 1-year lease \$100/month	mostly end user sales Purchase \$3,300 to \$7,000 Maintenance \$21/month 1-year lease \$80/month	mostly end user sales Purchase \$5,700 to \$12,000 Maintenance \$32/month 1-year lease \$138/month	mostly end user sales Purchase \$5,050 to \$5,595 Maintenance \$35/month 1-year lease \$190/month

HARDCOPY TERMINALS

photographic memories.

Cassette mag tape looks like the leader in popular terminal peripherals, bidding to displace the time-honored punched paper tape which goes back in history about to the voyages of Leif Ericsson. In a few instances a display or a crt is mentioned as a peripheral,

inescapable conclusion that the vast majority of interactive hardcopy terminals in the world are still from Teletype Corp. These reliable, unpretentious, modestly-priced devices are still able to take care of the needs of a great many people.

For the man who has everything, however, or who is only satisfied with the world's most complex, there is an excellent shopping list. Besides, if you

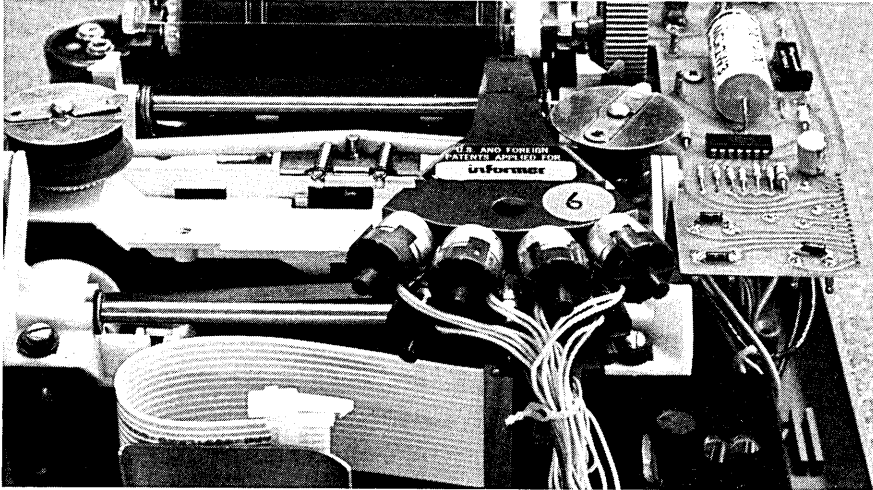

One of the now more common serial printing mechanisms is the dot matrix print head, which has solenoids driving pins against the paper. This one (shown in an H100/200 series printer from Informer Inc., Los Angeles) is made by Victor Comptometer.

giving pause for editorial thought about whether the device was actually in the right category for this survey. However, if all else seemed in order, it was accepted.

Random access (RAM), read-only (ROM), and programmable read-only memories (PROM) are found in varying combinations in many of the products listed.

Some vendors insisted in their replies that their sales are primarily to end users *and* primarily to original equipment manufacturers. Doubling a precise 50-50 split, we have listed such as end user suppliers. The typical shopping individual user, calling an oem supplier for info, is apt to be startled by the question, "How many hundred do you want to order?"

Oem suppliers frequently did not list lease and maintenance prices. This is reasonable, since they do not usually sell on such bases.

In general, the low prices, where there is a range, refer to the basic machine, often with something upon which to rest it, and something else with which to connect it. Options, which are not specifically stated as such, but can usually be inferred from the preceding descriptions, are concatenated to get up to the higher price.

For more information

If we look at volumes delivered, in the instances of those folks not too modest to so state, we come to the

can't find it here, just wait till next year. Christmas will come again.

If the supporting literature sent to us is any criterion, there is a wealth of interesting information and illustration awaiting the person who fills in the reader reply card.

Also, while the sunshine optimism of Pollyanna is unseemly for hard-bit-ten technological journalists, these are exciting products.

The world *has* made progress since the design of the first Kludge. *

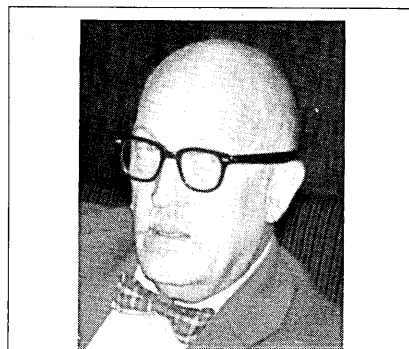

Mr. Granholm's dp experience began when he programmed dynamics problems on the IBM 602A and 605 for Boeing. His background includes both hardware and software apprenticeships, as well as consulting for various electronics firms. He has been a rather regular contributor to Datamation for over 15 years.

Vendor Index

The information in the tables in this article was collected from the manufacturers. For clarification or amplification of the data, please contact the manufacturers directly through the office listed in the Vendor Index or by circling the appropriate readership service number on the cards bound into the back of this issue.

ANDERSON JACOBSON INC.
1065 Morse Avenue
Sunnyvale, CA 94086
Established 1967; 435 employees
Gross sales \$2.7M
D. Reichel, prod mgr (408) 734-4030
FOR DATA CIRCLE 300 ON READER CARD

APPLIED COMPUTER SYSTEMS
248 Sobrante Way
Sunnyvale, CA 94086
Established 1972; 15 employees
Gross sales not released.
R. Gadsby, sales mgr (408) 733-3733
FOR DATA CIRCLE 301 ON READER CARD

APPLIED COMPUTING TECHNOLOGY, INC.
17961 Sky Park Circle
Irvine, CA 92707
Established 1972; 15 employees
Gross sales \$400K
N. Gleason, mktg dir (714) 557-9972
FOR DATA CIRCLE 302 ON READER CARD

BEDFORD COMPUTER SYSTEMS
3 Preston Court
Bedford, MA 01730
Established 1972; 20 employees
Gross sales \$1M
R. Trudeau, pres (617) 275-0870
FOR DATA CIRCLE 303 ON READER CARD

J. BEENE ASSOCIATES
P.O. Box 806
Greensburg, PA 15601
Gross sales not released
J. L. Beene, owner (412) 834-0322
FOR DATA CIRCLE 304 ON READER CARD

BURROUGHS CORPORATION
Burroughs Place
Detroit, MI 48232
Established 1886; 51,500 employees
Gross sales \$1.5B
K. Perrin, dist supv (313) 972-7000
FOR DATA CIRCLE 305 ON READER CARD

CENTRONICS DATA COMPUTER
1 Wall Street
Hudson, NH 03051
Established 1968; 683 employees
Gross sales \$41.5M
D. Campbell, mgr mktg service
(603) 883-0111
FOR DATA CIRCLE 306 ON READER CARD

COMDATA CORPORATION
8115 Monticello
Skokie, IL 60076
Established 1968; 70 employees
Gross sales not released.
W. L. Manning, sales mgr
(312) 677-3900
FOR DATA CIRCLE 307 ON READER CARD

COMPRO CORPORATION
3001 Redhill Avenue Bldg VI-103
Costa Mesa, CA 92626
Established 1972; 5 employees
Gross sales not released
F. Scholnick, pres (714) 540-7153
FOR DATA CIRCLE 308 ON READER CARD

COMPUTER DEVICES INC.
9 Ray Avenue
Burlington, MA 01803
Established 1969; 125 employees
Gross sales \$5-10M
B. Sanford, mgr sales (617) 273-1550
FOR DATA CIRCLE 309 ON READER CARD

COMPUTER TRANSCEIVER SYSTEMS, INC.
E66 Midland Avenue
Paramus, NJ 07652
Established 1968; 72 employees
Gross sales not released.
C. Kaplan, natl sales manager
(201) 261-6800
FOR DATA CIRCLE 310 ON READER CARD

DATA ACCESS SYSTEMS INC.
100 Route 46
Mountain Lakes, NJ 07046
Established 1968
Gross sales \$4.5M
M. Vincent, reg sales manager
(201) 335-3322
FOR DATA CIRCLE 311 ON READER CARD

DATA PRODUCTS—STELMA TELECOMMUNICATIONS
17 Amelia Place
Stamford, CT 06904
Gross sales not released.
R. M. Samose, mktg mgr (203) 325-4161
FOR DATA CIRCLE 312 ON READER CARD

DATA TERMINALS AND COMMUNICATIONS
1190 Dell Avenue
Campbell, CA 95008
Established 1968; 63 employees
Gross sales \$2.5M
E. Simdt, natl sales mgr (408) 378-1112
FOR DATA CIRCLE 313 ON READER CARD

DI-AN CONTROLS INC.
944 Dorchester Avenue
Boston, MA 02125
Established 1958; 150 employees
Gross sales \$4M
H. Smith, sales mgr (617) 288-7700
FOR DATA CIRCLE 314 ON READER CARD

DIGITAL EQUIPMENT CORP.
1 Iron Way
Marlborough, MA 01752
Gross sales not released.
J. Wolaver, prod mgr (617) 481-7400
FOR DATA CIRCLE 315 ON READER CARD

EXTEL CORPORATION
310 Anthony Trail
Northbrook, IL 60015
Established 1964; 285 employees
Gross sales \$12M
W. E. Balazs, mgr mktg service
(312) 564-2600
FOR DATA CIRCLE 316 ON READER CARD

FACIT-ADDO, INC.
66 Field Point Road
Greenwich, CT 06830
Gross sales not released.
O. Bjerkmann, prod mgr (203) 622-9150
FOR DATA CIRCLE 317 ON READER CARD

GENCOM SYSTEMS, INC.
1151 Triton Drive
Foster City, CA 94404
Established 1973; 50 employees
Gross sales \$4M
W. F. Chamberlain, pres (415) 349-2374
FOR DATA CIRCLE 318 ON READER CARD

GENERAL ELECTRIC DATA COMMUNICATION PRODUCTS
GE Drive
Waynesboro, VA 22980
Established 1969; 2500 employees
Gross sales \$multi M
C. F. Rockwell, advtsg & sales prom mgr (703) 942-8161
FOR DATA CIRCLE 319 ON READER CARD

HARRIS DATA COMMUNICATIONS DIVISION
11262 Indian Trail
Dallas, TX 75234
Established 1972; 700 employees
Gross sales not released
G. Brunner, advtsg mgr (214) 620-4382
FOR DATA CIRCLE 320 ON READER CARD

IBM CORPORATION
1133 Westchester Avenue
White Plains, NY 10604
Gross sales not released.
(914) 696-1900
FOR DATA CIRCLE 321 ON READER CARD

INTERDATA, INC.
2 Crescent Place
Oceanport, NJ 07757
Established 1966; 1150 employees
Gross sales \$35M
C. J. Hoppin, pub rel mgr
(201) 229-4040
FOR DATA CIRCLE 323 ON READER CARD

LOGABAX, U.S. DIVISION
10889 Wilshire Boulevard
Los Angeles, CA 90024
Established 1834; 2000 employees
Gross sales \$44M
R. L. Swarz, sales mgr (213) 477-0494
FOR DATA CIRCLE 324 ON READER CARD

MEMOREX CORPORATION
San Tomas at Central Expressway
Santa Clara, CA 95052
Established 1961; 4,800 employees
Gross sales \$217M
R. Farrow, prod sales manager
(408) 987-1542
FOR DATA CIRCLE 325 ON READER CARD

MI² DATA SYSTEMS, INC.
930 Kinnear Road
Columbus, OH 43212
Established 1969
Gross sales \$3M
G. Gerhard, VP mktg (614) 481-8881
FOR DATA CIRCLE 326 ON READER CARD

NCR CORPORATION
Main & K Streets
Dayton, OH 45479
Established 1884; 78,000 employees
Gross sales \$1.98B
Contact local sales/service office
(513) 449-2000
FOR DATA CIRCLE 327 ON READER CARD

S.C.M. KLEINSCHMIDT
Lake-Cook Road
Deerfield, IL 60015
Established 1931; 189 employees
Gross sales \$9M
D. O. Myers, sales dir (312) 945-1000
FOR DATA CIRCLE 328 ON READER CARD

SCOPE DATA INC.
3728 Silver Star Road
Orlando, FL 32808
Established 1972; 60 employees
Gross sales not released.
A. G. Smith, vp mktg (305) 298-0500
FOR DATA CIRCLE 329 ON READER CARD

SIDEREAL CORP.
4118 Southwest Macadam
Box 1042, Portland, OR 97207
Established 1970; 100 employees
Gross sales not released
J. Tripp, prod mgr (800) 547-6716
FOR DATA CIRCLE 338 ON READER CARD

SINGER BUSINESS MACHINES
(formerly International Teleprinter)
2350 Washington Avenue
San Leandro, CA 94577
Established 1964; 12,000 employees
Gross sales \$400M
J. E. Greenwood, natl sales manager
(415) 357-6800
FOR DATA CIRCLE 330 ON READER CARD

TALLY CORPORATION
8301 S. 180th Street
Kent, WA 98031
Established 1945; 500 employees
Gross sales \$18M
W. D. del Valle, natl sales manager
(206) 251-5536
FOR DATA CIRCLE 331 ON READER CARD

TELETYPE CORPORATION
5555 Touhy Avenue
Skokie, IL 60076
Established 1930; 4600 employees
Gross sales \$179M
D. F. Corkle, sales mgr (312) 982-2400
FOR DATA CIRCLE 332 ON READER CARD

TEXAS INSTRUMENTS, INC.
P.O. Box 1444
Houston, TX 77478
Gross sales not released.
B. Bauman, mkt dev & planning
(713) 494-5115
FOR DATA CIRCLE 333 ON READER CARD

TRENDATA CORPORATION
610 Palomar Avenue
Sunnyvale, CA 94086
Established 1970; 200 employees
Gross sales not released.
P. Jantzen, dir mktg svc (408) 732-1790
FOR DATA CIRCLE 334 ON READER CARD

TYCOM SYSTEMS CORP.
26 Just Road
Fairfield, NJ 07006
Established 1968; 65 employees
Gross sales \$4M
P. F. Polizzano, dir mktg (201) 227-4141
FOR DATA CIRCLE 335 ON READER CARD

UNIVAC (SPERRY-UNIVAC)
Subsidiary of Sperry Rand Corp.
Box 500
Blue Bell, PA 19422
55,000 employees
Gross sales \$1.3B
W. R. Wasson, dir prg mgt
(215) 542-4391
FOR DATA CIRCLE 336 ON READER CARD

XEROX CORPORATION
Data Systems Division
701 S. Aviation Boulevard
El Segundo, CA 90245
Established 1969; 4,000 employees
Gross sales \$100M
W. R. Walker, prod mgr (213) 679-4511
FOR DATA CIRCLE 337 ON READER CARD

The Ten Laws of Teleprocessing

by David Hebditch

While ruminating on a Yorkshire hill, all suddenly became clear.

Why, I would ask myself, is the orderly and timely implementation of cost effective teleprocessing systems still so rarely achieved? Perhaps other laws we are yet unaware of also influence the on-line course of our lives?

While ruminating on Yorkshire hilltops, the truth was suddenly revealed to me in the form of immutable and immortal laws—the Ten Laws of Teleprocessing. Briefly here they are as they came to me:

The First Law: *Eighty percent of everything you learned installing batch systems will not be relevant to your on-line project and 80% of that 80% will be positively dangerous to apply.*

The major problem areas are performance estimating (how do you benchmark a network?), user/terminal interaction (which user? where?), network “failsafety” and management (no longer are users buffered from central-site failures by the inherent inefficiencies of batch systems), software (how do we ever find out if it works without actually implementing it?), and equipment selection (there are now over 300 terminals on the world market, none of which is suitable for my application). Retraining is not the only answer; there is no substitute for relevant experience.

The Second Law: *The number of problems encountered during and after implementation is directly proportional to n^2 , where n is equal to the number of suppliers involved in the system.*

According to this law, the “problem factor” of single-supplier batch systems is 1. Therefore, teleprocessing systems automatically have a problem factor of at least 4 because you also have to deal with a common carrier. Now, if you get terminals from someone other than your mainframe supplier, the problem factor goes up to 9—that is you are going to get about nine times the number of problems you would have had if you stuck to a simple batch system. . . . Now where were you going to get your modems and concentrators from?

The Third Law: *The ideal terminal for your system is the one which has just been announced but not yet delivered nor installed.*

Those in the know often refer to this law as “the moving target syndrome.” Terminal developments are currently taking place much more quickly than we are able to implement the damn things. The time lag between signing a contract for terminals and actually installing them is usually such that there is always a cheaper, more effective equivalent available by switchover time; “if it is working it must be obsolete.” Therefore, all existing teleprocessing systems use less than the best possible terminal for the job.

The Fourth Law: *Successful on-line systems expand until they become unworkable.*

Just as King Kong had to meet Godzilla, it was inevitable that the Peter Principle should collide with the Turnpike Effect.

The more successful an on-line system is, the more it will be taken advantage of by users, and the pressure will then be on the dp department to incorporate additional facilities and new applications.

This law is related to the “Peter Principle” which says that managers in an organization will rise to their level of incontinence, sorry—incompetence. With teleprocessing systems, it is often not known how new applications will affect response times and throughput until they go “live,” and by that time it could be too late—you have already spent your dollars.

Just to make things worse, increases in linear traffic lead to exponential increases in response times. In other words, doubling the traffic will much more than double the response times. Nothing breeds failure like success.

The Fifth Law: *The modem currently in short supply will be Modem No. X where X = the number of the modem you require for the system.*

Unfortunately, the Carterfone Ruling is not effective in the U.K. and we are even obliged to use Post Office supplied modems if we wish to transmit on the public telephone network. This would not matter too much if the Post Office did not have a flair for lousing up the supply of such modems. For non-U.K. readers, feel free to substitute your own law relating to your own common carrier situation.

The Sixth Law: *The crt screen content will expand to fill the capacity of the screen.*

This is one of a number of sublaws influencing the design of terminal dialogues, the all important language of communication between the user and the system. Unfortunately, dialogues still tend to be designed by batch oriented systems analysts (and, even worse, programmers) who feel that they have to justify their existence by maximizing the utilization of everything in sight (including crt screens). They also impose their own jargon on users who think that “fields” are where cattle masticate grass (the green sort) and “characters” are always played by Walter Matthau.

The design of terminal dialogues is quite different from, say, designing card formats or tape file records. Much work still needs to be done to identify dialogue design as an area of special consideration and to develop appropriate standards. As usual Shakespeare had the right words to express the user’s view:

“You taught me language; and my profit on’t
Is, I know how to curse. The red plague rid you
For learning me your language!”

The Tempest, Act 1, Scene 2

The Seventh Law: *Each extra 1% of system availability will cost you at least twice as much as the last 1%.*

The nature of on-line systems makes “failsafety” much more critical than it ever was with most batch systems. With the latter, remote users often sent input data to the computer center by mail or messenger for keypunching, verifying, editing, correcting, and processing before output reports were dispatched in a similar manner. The overall turnaround of three or more days often meant that the odd five or six-hour breakdown went unnoticed.

However, the installation of terminals for the convenient and prompt processing of data as an integral part of the users’ day-to-day activities means that five or six-hour breakdowns are noticed. A stable, predictable, working sys-

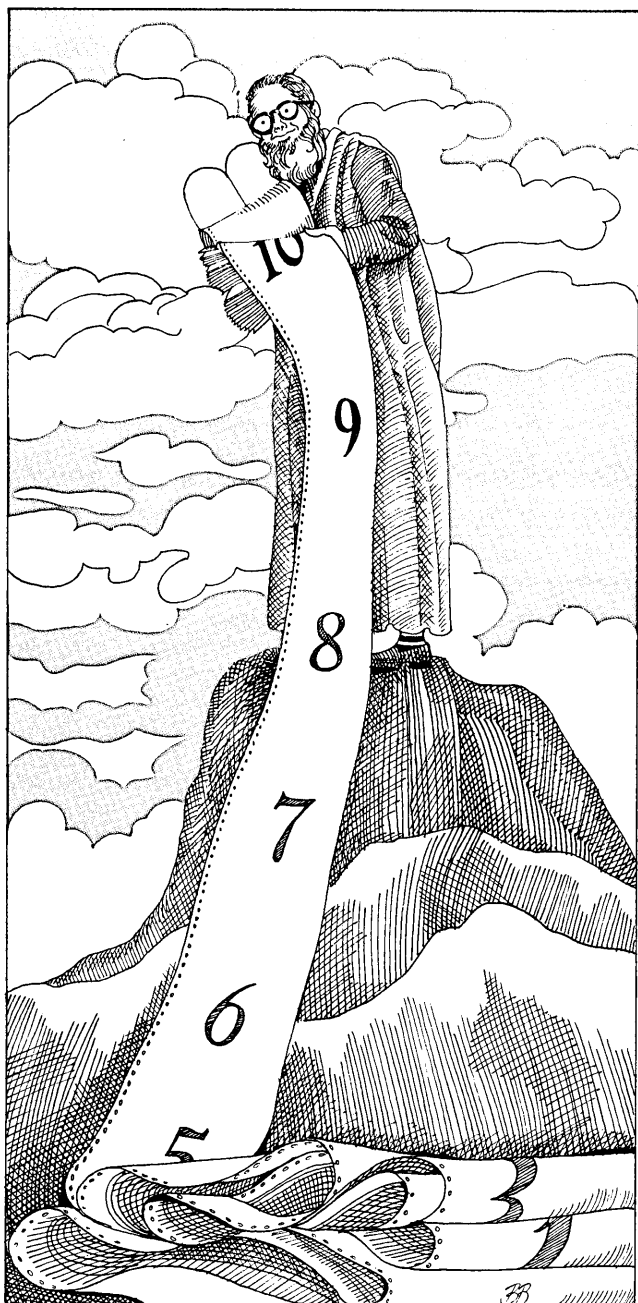

tem becomes the standard and has to be maintained. Management sometimes makes the mistake of asking for 100% availability and, of course, there ain't no such thing. Furthermore, each extra 1% availability becomes increasingly hard to justify, especially with the generally high availability of most of today's hardware system components. Tom Gilb came to the same conclusion when he said "The cost of total reliability is infinite cost" ("Laws of Unreliability," March, p. 81).

The Eighth Law: Teleprocessing programs never work.

The longer a teleprocessing program runs, the longer its mean time between failures will be (as you would expect). However, for on-line programs of any complexity at all, the possible combinations of message type, message arrival time, etc., must tend to infinity; and those combinations which will cause failure might rarely, if ever, occur during a five-year project life and might be impossible to generate under test conditions. In fact, the problem of simulating true line network conditions with realistic traffic patterns is so difficult that over 50% of debugging teleprocessing programs probably takes place after the first terminals go operational. Again Tom Gilb's own ruminations led him to

the same conclusion: "All real programs contain errors until proved otherwise—which is impossible."

The Ninth Law: The simpler, the smaller and less ambitious a teleprocessing system is, the harder it is to justify, the harder it is to implement, and the less well it will perform.

Most mainframe manufacturers have not geared their computers to make it easy to implement on-line systems of just a few terminals (and 80% of on-line systems in the U.K. have less than 10 terminals). If you wish to put one terminal (for inquiries say) on your IBM 370/158, it will cost you about \$100,000 in hardware excluding the cost of the terminal—which is rather like being forced to buy a Cadillac when all you need is a dunebuggy.

Now it is not going to be worth devoting a lot of effort to implementing such a system, so we will send someone to a CICS course and he can scribble off the application program in COBOL. Consequently not enough solid experience and attention to detail goes into what is a critical first step into the field of teleprocessing. The number of 2-10 terminal systems on general purpose mainframes which have abominable response times is amazing, and this does much to discredit the technique. (The emergence of Systems Network Architecture does not bode well for low budget systems either.)

The truth of the matter is that smaller on-line installations require almost as much design and development effort as the large ones, and this is neither appreciated by many dp managers nor made clear by the manufacturers. The use of experienced, specialist teleprocessing consultants can often be an effective and economical way out . . . but there I go, changing the subject.

The Tenth Law: The numerically greatest component of the on-line system will be the terminal user; the least well specified and least understood component will be the terminal user.

On the whole we design our teleprocessing systems the wrong way 'round. We start with the cpu and work outwards. Terminals are seen as additional peripherals installed in awkward places. But for the user, the terminal is all he sees of the system.

The introduction of batch systems tended to have a relatively minor effect on user departments. Terminal systems, however, often lead to radical changes in the structure of user departments and the nature of the jobs of the people who work in them. In fact, the reason for installing such systems in the first place is usually to make such changes in the hope that they effect "improved efficiency," "higher profitability," etc.

The lack of appreciation of how such changes influence users' levels of job satisfaction (or dissatisfaction) often causes failure of the new system in meeting its stated objectives (if they ever were stated). Only with the inclusion of social objectives in the terms of reference, in addition to technical and economic objectives, will the full potential of teleprocessing be achieved.

No one has yet devised a way of *forcing* people to accept changes which they do not see as being in their interest. Many dp professionals do not yet accept the principles involved and those who do tend to descend on users in the guise of latter day technological Captain Marvels to save them from a life of boredom. If appropriate practical standards are not developed, I can see many data communications networks becoming for systems designers what "high rise" apartment blocks have become for architects and city planners. *

Mr. Hebditch has been an independent dp consultant for the past five years. He was earlier associated with Schweppes Ltd. and with the Halifax Building Society where he was responsible for teleprocessing systems. He lectures widely in Europe, and has authored a number of articles and the book, "Data Communications: An Introductory Guide."

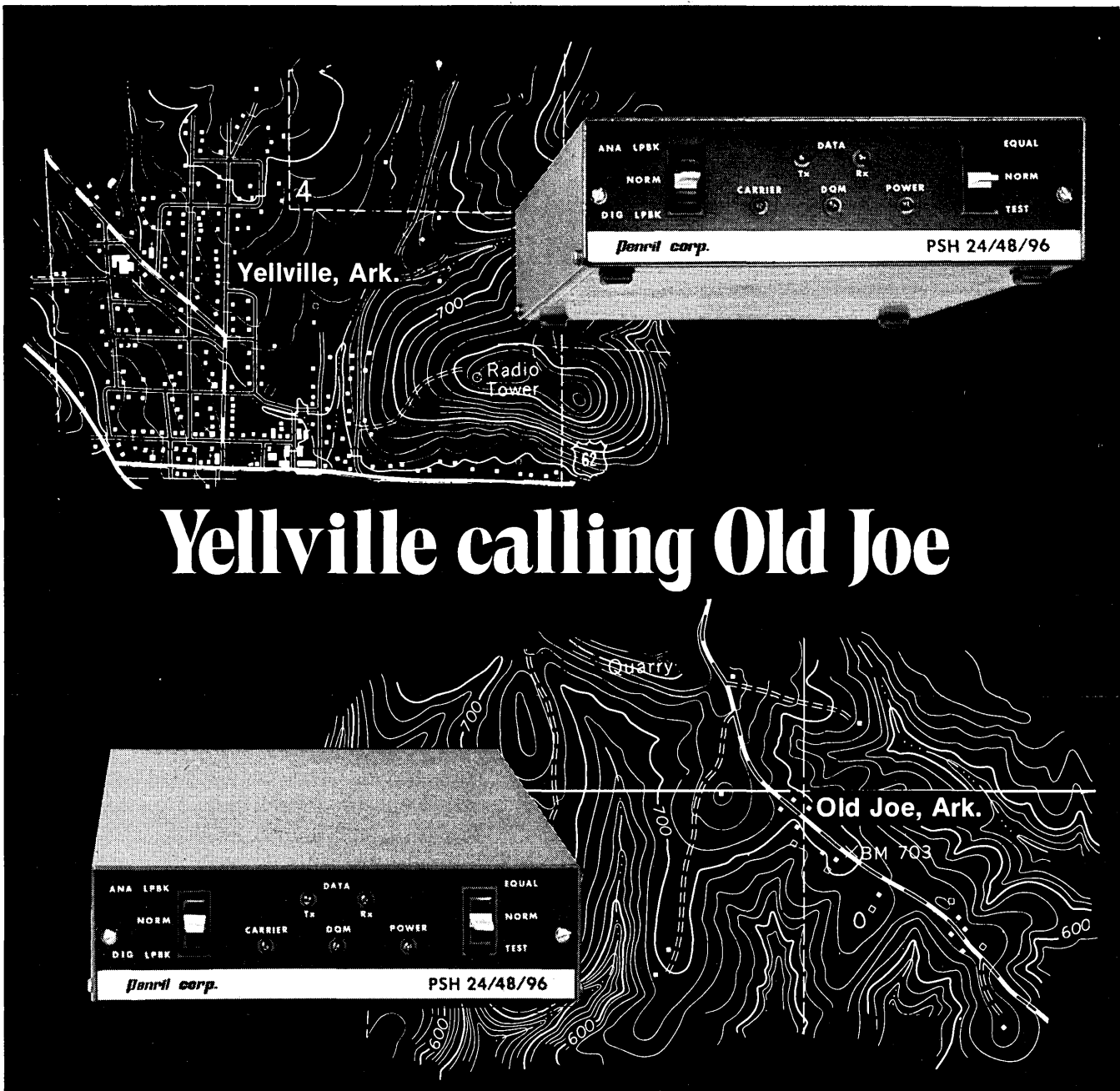

Yellville calling Old Joe

As the crow flies it's 25 miles from Yellville to Old Joe, Arkansas. Old Joe isn't quite ready for a data communications link to Yellville. But when the time comes it will be a natural application for Penril Short Haul modems.

The Short Hauls are a family of synchronous and asynchronous modems with speeds ranging from 0 to 1,000,000 bits per second. They are capable of transmitting large amounts of data from room-to-room or distances up to 35 miles, reducing computer usage significantly. Self-test diagnostics, typical bit error rates of better than 1×10^{-8} , and a MTBF expectancy of 150,000 hours are standard features. Single unit prices start at \$235. There's no point

in using expensive, long distance modems for local data communications networks when Penril offers a hoot-and-a-holler model for a fraction of the price. That's something to shout about in Yellville, or any place else.

There must be a good reason why there are thousands of **Penril modems** in use today.

Penril Corp. / Data Communications Division

5520 Randolph Road • Rockville, Maryland 20852
301/881-8151

YOUR PAPER WORRIES ARE OVER!

GRAPHIC CONTROLS DELIVERS.



Texas Instruments Silent 700®

We offer you fast, off-the-shelf delivery, from inventory, of thermal paper to fit the **Texas Instruments Silent 700®** machines. No problem for us. We produce in quantity and stock in distribution centers strategically located throughout the U.S. and Canada. You'll never run short again!

And that's not all. We'll supply you with paper that's whiter and easier to read than you're now using. In addition to our standard roll paper, we give you the option of fan fold packs, and cross-perforated roll paper... perforated every 11 inches. And we offer production flexibility for letterheads and special formats.

All this and low price, too. **Lowest price in the industry!**

So, stop worrying and start filling out the coupon. For even faster action, call the Coated Products Division—Sales Service Dept., at (716) 853-7500, Ext. 378. Graphic Controls delivers!

Please start me off with a complimentary roll and your brochure showing the lowest prices in the industry.

Number of your Silent 700 Machines _____
Estimated annual usage _____ rolls.

I have an immediate need—have your representative call.

Name _____

Company _____

Address _____ Phone No. _____

City _____ State _____ Zip _____



COATED PRODUCTS DIVISION
GRAPHIC CONTROLS CORPORATION
189 VAN RENSSELAER STREET, BUFFALO, NEW YORK 14210

In 1969 we introduced the fastest, most powerful supermini available.

In 1971 we introduced the fastest, most powerful supermini available.

In 1973 we introduced the fastest, most powerful supermini available.

Now meet SLASH 7

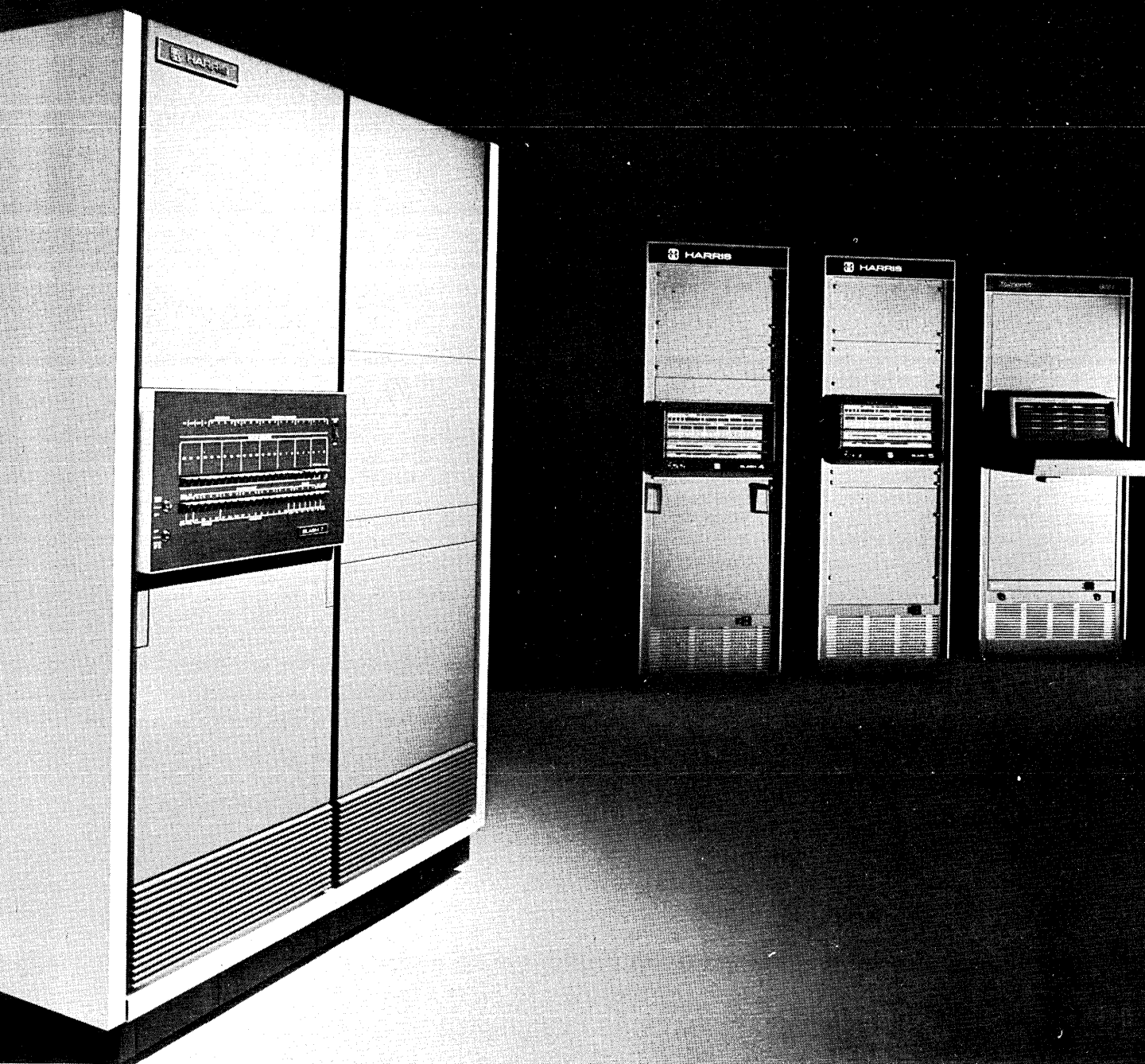

SLASH 7.

The newest,
fastest,
most powerful
supermini anyone ever
built...even us.

You can see that SLASH 7's heredity is speed and power. The kind of innate speed and number-crunching power that real-time FORTRAN programming takes advantage of. The kind of speed and power that has made the term "computer limited" obsolete.

SLASH 7 is the SuperMini in more ways. Its supported by software that's been tested and retested, validated and revalidated, proven and reproven countless thousands of times in demanding user situations. And, supported by a complete line of high-performance standard peripherals.

The Harris SLASH 7's super specs and capabilities are impressive. For example: multiprocessor capabilities, multiported core and bipolar memories, I/O

processors, concurrent real-time batch, and interactive processing.

CPU cycle time: 425 ns (minimum)

Maximum DMA rate per second: 15MB

Integer add (register to memory): 0.95 microseconds,

multiply: 2.22 microseconds,

divide: 6.37 microseconds

Specs good enough to win any benchmark; we'd like to run one for you.

And while SLASH 7's capabilities far surpass competitive machines, our prices do not. Get all the facts about SLASH 7, the SuperMini, and compare them yourself.

Write Harris Computer Systems, 1200 Gateway Drive, Fort Lauderdale, Florida 33309, Europe: Techmation N.V., Gebouw 105/106 Schiphol-Oost, Netherlands.

HARRIS

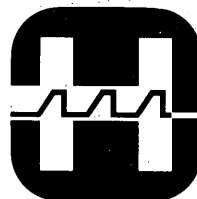

**COMMUNICATIONS AND
INFORMATION HANDLING**

CIRCLE 42 ON READER CARD

New from Kodak.

The bright new way to read COM fiche.

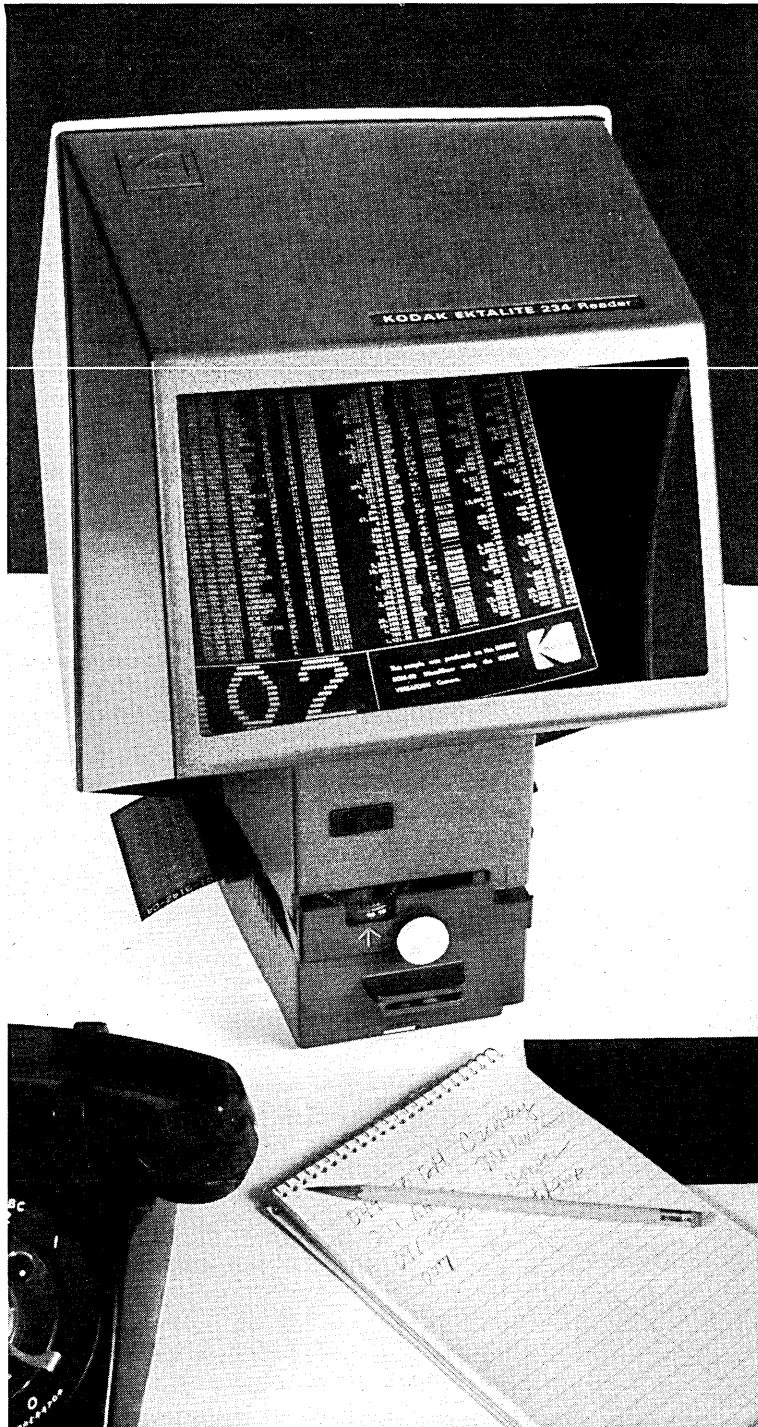

The more you're into COM-generated microfiche, the more valuable you're going to find the new Kodak Ektalite reader, 200 series. It makes fiche reading easy and gives you full-text viewing of 14" x 11" computer pages.

The secret of its brightness is a special reflection-type screen that displays a crisp, clear image—even under bright room light.

Of course, you can also use this low-cost reader for regular 8½" x 11" source documents on fiche or in film jackets. Color microfiche, too.

Designed to meet the need for multiple reader installations, the new Ektalite reader is not only priced low, it's also economical to operate. It runs on a low-wattage, automotive-type light bulb. This can reduce energy consumption by as much as \$50 a year compared with some fan-cooled readers.

Contact your Kodak representative today for a demonstration. Eastman Kodak Company, Business Systems Markets Division, DP5819, Rochester, N.Y. 14650.

What you're saving now with microfilm is only the beginning.



You may have spent enough on timesharing to buy three timesharing computers.



At one time, the only way many people could afford to use a computer was to go to a timesharing service.

But that's no longer the case. Nowadays, a timesharing service can cost you a small fortune.

Because you don't just pay for computer time. You also have to pay for connect time. Memory time. Disc time. Tape time. You even have to pay for back-up files any time you need them.

By the time you finish paying off your timesharing bills, you may have ended up spending enough to buy one of our timesharing computers. (Believe it or not, there actually are those who have spent enough for three of our computers.)

Small computers are costing a lot less than they used to. So our computers can cost as little as \$6500. (For a single user system with 32K bytes of MOS memory, teletypewriter, our Stand-alone Operating System and Extended BASIC.)

And they can cost as much as \$87,405. (For a system that can handle 16 timesharing terminals concurrently and also do batch processing in the background. It has 138K bytes of core, a CRT, 10 megabyte disc, mag tape unit, card reader, printer, Extended BASIC, FORTRAN and our Mapped Real-time Disc Operating System.)

So, somewhere between those two extremes there has to be a system that does just what you're now doing, for a lot less than you're now paying your timesharing service.

And when you buy a timesharing system from Data General, you get to use all the timesharing programs in the Data General program library. Including such favorites as the Stanford Business Library and Dartmouth Statistical Package.

So, instead of sending money to your timesharing service, send us a request for more information.

It won't cost you anything.

Please send

DAT

- A Data General Sales Engineer.
- Technical information on computational timesharing systems.
- Information as to how people have switched from a timesharing service to a Data General system.

NAME

TITLE

COMPANY

ADDRESS

CITY

STATE

ZIP

PHONE

Data General

◆ Data General, Dept. K1, Route 9, Southboro, Mass. 01772 (617) 485-9100. Data General (Canada) Ltd., Ontario. Data General Europe, 15 Rue Le Sueur, Paris 75116, France. Data General Australia, Melbourne (03) 82-1361/Sydney (02) 908-1366.

Progress Report:

370/158 USERS: NOW YOU CAN RECONFIGURE YOUR MEMORY, DUPLEX IT, BACK IT UP, EXPAND IT TO 4 MEGS, AND SAVE UP TO 40%.

How?

With Cambridge's new 370/STOR 158-3 add-on-memory system that expands most models of the IBM System/370 Model 158 processor, including the new Mod 3 versions.

370/STOR 158-3 is the newest in a line of memories that has made Cambridge the largest independent memory supplier to System/370 processors — with over 250 megabytes installed. That success has been the result of building products with performance features that go beyond the ordinary. And 370/STOR 158-3 has plenty of them.

Features like easy interconnection. Impeccable reliability. The ability to do more with our

memory than with anyone else's. For example, your operators can quickly shift either 370/STOR or host IBM memory to off-line status, while the other memory runs. Or you can reconfigure the size of operating memory with just a simple switch setting. Or you can back-up either main memory, or "bump" memory, if you need to do so.

Whether your Model 158 processor is purchased or rented, you can save up to 40 per cent on the memory attached to it. It's as easy as ordering 370/STOR 158-3.

Find out more from your local Cambridge sales office listed below.

CAMBRIDGE.

A good place to put your information.



Cambridge Memories, Inc., 12 Crosby Drive, Bedford, Mass. 01730 (617) 271-6400

Contact our sales offices for further information: Boston (617) 271-6400 • Westport, Conn. (203) 227-7027 • Philadelphia (215) 295-1186 • Cleveland (216) 842-2808 • Columbus, O. (614) 459-0154 • Atlanta (404) 252-1382 • Hollywood, Fla. (305) 925-3348 • San Francisco (415) 692-4806 • New York City (201) 871-0110 • Rochester (716) 637-2410 • Chicago (312) 449-5260 • Detroit (313) 557-4080 • Washington, D.C. (703) 683-5323 • Dallas (214) 231-4804 • Houston (713) 661-0381 • Los Angeles (213) 595-1845 • Charlotte, N.C. (704) 568-1787 • St. Louis, Mo. (314) 822-2212 • Minneapolis (612) 831-1311
Subsidiary: Cambridge Memories GmbH, 6078 Neu Isenburg, West Germany 06102-36092 • Cambridge Memories AG, CH 8002 Zurich, Switzerland 00411-253824.

IBM's Minicomputer, The 5100

by Michael Cashman, Associate Editor

IBM's interest in the low end of the marketplace reached a new high . . .

Shockwaves rumbled out of Atlanta, Georgia in early September as IBM's General Systems Division announced possibly the most interesting product since IBM's introduction of the 370/145 half a decade ago. The 5100 is a portable computer, complete with integrated crt console, tape cartridge drive, up to 64K of memory, high-level language interpreters for BASIC and APL available at the flick of a switch, and hardcopy and communications capability. All crammed into 50 pounds and available with a beautiful (optional) leather-looking carrying bag (\$125). Before analyzing the place of the 5100 in the realm of things, a closer look at the machine is in order both to show what it can and cannot do, and because it is so technologically interesting.

The hardware

IBM busied itself during September 9 announcement week by pointing out to potential customers and the press that the 5100 contained exactly as much memory as the 360/30 announced 11 years ago. While the 5100 isn't about to displace any 360s, it is still a benchmark of the technological progress made that 64K of storage can now be

placed in a box about the size of a Selectric typewriter. Memory sizes are available in 16K chunks between 16K and 64K, with each 16K module adding an additional \$3K to the basic \$8,975 price of the machine. Only 4K of main storage is reserved for system control—which is a lot less than was required on the 360/30. The Metal Oxide Semiconductor Field Effect Transistor (MOSFET) main storage has an access time of 354 nsec and 530 nsec cycle time. Another memory is used to store the APL and/or BASIC language interpreters.

It seems like a long time since IBM announced a product that didn't use a flexible disc drive, but the 5100 is such a machine. Auxiliary memory is in the form of a magnetic tape cartridge built under license from 3M that stores 206 kilobytes of storage. The cartridge drive is built into the front panel of the 5100. A second cartridge drive is available for the 5100 (\$2,300) which would enable a user to sort larger files, and a 132-column printer that operates at 80 cps is available for hardcopy requirements (\$3,675). Back to the built-ins: a 10-key calculator pad for data entry, and a miniature crt screen capable of displaying 16 lines of 64 characters (1,024). IBM foresaw

some squawking from users who couldn't make out all the data on the screen and has come up with either an answer or a compromise. A switch on the 5100's front panel inserts blanks between display characters, separating the left 32 or the right 32 characters and making them easier to read. If the machine is vulnerable from such competitors as Wang and Hewlett-Packard, it might be because of the very small crt, but for most users it may be adequate. A jack on the back of the 5100 can be used to attach external black and white tv monitors, certainly of interest in the education markets. Communications is in the form of an adapter that makes the 5100 appear to be a 2741 terminal to other IBM gear, and 300 baud (30 cps) is the transmission speed.

Markets and competition

Though announced primarily for "problem solvers in business, engineering, and scientific disciplines," IBM showed some signs of not knowing where the business might come from—which is to be expected with such a new product. One wonders two things about the potential markets IBM recognizes: just how many "problem solv-

PROBLEM SOLVER LIBRARIES...Announced with the initial version of the 5100 portable computer were routines for performing common functions in business, mathematics, and statistics. Each problem solver library consists of two magnetic tape cartridges and a self-study user's guide. The price for each set is \$500. The routines are designed to prompt and guide the user through to the completion of the routine. The business package is available in BASIC only; the mathematics and statistics sets come in both APL and BASIC. Below are listed typical capabilities of the routines.

BUSINESS (30 BASIC ROUTINES)

- * Spread Sheet Analysis
- * Investment Analysis
- * Break Even Analysis
- * Depreciation
- * Time Series Analysis
- * Graphic Presentation Capability

MATHEMATICS (44 BASIC or 37 APL ROUTINES)

- * Linear equations, matrix eigenvalue problem
- * Zeros of polynomials, zeros and minimal of functions
- * Quadrature/differentiation
- * Interpolation, approximation and smoothing
- * Ordinary differentiation equations
- * Discrete Fourier transform
- * Special Functions
- * Linear Programming

STATISTICS (41 BASIC or 40 APL ROUTINES)

- * Data Generation
- * Elementary Statistics
- * Regression and Correlation Analysis
- * Multivariate Analysis
- * Analysis of Variance
- * Nonparametric Statistics
- * Time Series Analysis
- * Biostatistics

THE 5100

ers" are there in the country, and secondly, what are they using now? At this point it should be pointed out that there are two comparable machines that have been on the market, well thought of by customers, and marketed aggressively by two talented companies. The products are the Hewlett-Packard 9830 programmable (BASIC) calculator, and Wang Laboratories 2200 series units, also programmable in BASIC. In three years of marketing, H-P has certainly sold less than 10,000 units, probably closer to five, although the firm wouldn't state what its success had been, saying only that more than 3,000 had been sold. Wang Laboratories, the leader in the field, has more than 5,000 model 2200s installed worldwide. There certainly are more people solving problems in this country than these numbers suggest. In fact, the numbers suggest that if H-P and Wang could sell several thousand units, IBM should be able, with its market coverage, to sell many, many, times that amount. Something to remember: if just one company in 10, out of the estimated two million businesses in the U.S. acquired an IBM 5100 to give it better financial and market planning, and to help generate the increasing numbers of reports required by various levels of government, there could be several hundred thousand 5100s in use by 1980.

What is the problem solver using now? Many of them undoubtedly bought models of Hewlett-Packard and Texas Instrument handheld (even programmable) calculators, though the IBM 5100 is considerably more powerful. There can be little doubt that the 5100 will be scrutinized by time-sharing users. IBM's 5100 brochure spells it out: "A computer that's yours instead of everybody's." There could be some interesting implications for in-house time-sharing users such as engineers and scientists, and also for users going outside for services. And certainly the harried dp manager in large shops will have to consider the meaning of the 5100—especially if users all over the company start queuing up to purchase the new machine. It may become even harder for organizations to keep accurate track of just how much computing is being done, and at what cost.

First reactions

Ted Withington, computer analyst for Arthur D. Little, described the 5100 as "an excellent and effective competitor" to many time-sharing operations and to the Hewlett-Packard and Wang Laboratories products. "I suspect that what will cause the product to succeed will be the software

made available for it. I'm just a little surprised that more communications capability wasn't built into it that would allow, for example, an economist to chew away on a corporate data base. The machine's APL capability is a real eye opener, and A. D. Little is placing an order for one on this alone." A university dp user contacted thought the 5100 was just what he needed. "It's worth it to me to have a machine for less than \$10K to teach APL with."

Data General's minicomputer engineers took a look at the 5100 at the INFO/75 show in New York and were reportedly very impressed, "particularly in the power supply portion. They (IBM engineers) are doing some very interesting things lately," said one, referring to the power supply's light weight and compactness.

Dr. An Wang, President of Wang Laboratories, Tewksbury, Mass., probably has good reason to be less than

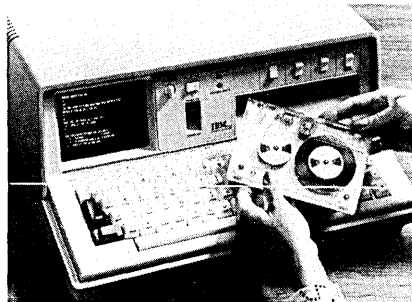

It doesn't look like an IBM computer, does it? Yet the 5100 contains two languages (interpreters for APL and BASIC), a crt console, a "tape drive" (a version of 3M's DC300 built under license), an additional tape cartridge unit if you desire, up to 64K of semiconductor memory, communications and hardcopy capability. About the only hand holding that will occur around this IBM product, however, will be the user removing or inserting the data cartridge: the 5100 is for sale only, installed, and checked out by the purchaser.

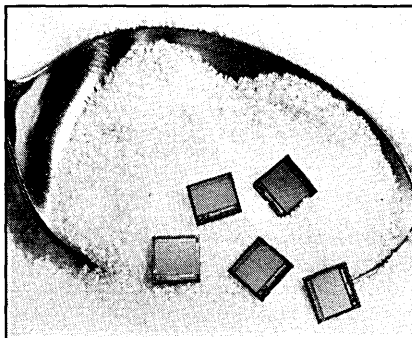

Metal Oxide Semiconductor Field Effect Transistor (MOSFET) Read Only Storage (ROS) is used in the 5100 to hold the APL and/or BASIC interpreters. Shown in a teaspoon full of sugar crystals for comparison, each chip, approximately .23-inch square, contains 48K bits. IBM would not reveal performance figures for the densest capacity chip yet used in its product designs.

highly enthused on the new IBM machine, considering that such small-scale computing products are his firm's specialty. "It's once again a case of somebody opening up a market, in this case us, and then they come in. I don't think it's such an engineering masterpiece: it's two-to-four times slower than our product, uses, in some cases five locations of memory to store what we store in one, etc. That small crt screen won't help the product, and it's much more expensive. I just wish that everybody who will look at the 5100 would take the time to look at ours."

"The APL thing really confuses me," says Wang's Senior Vice President of North American Operations, John Cunningham. "I can't remember, out of 3,022 systems sold in North America during the last three years, four deals we've lost because we lacked APL. But we could have sold 100 more if we'd had FORTRAN."

Alexis Sozonoff, Hewlett-Packard Calculator Division Manager disagreed. "APL is the real contribution of this machine. Here's a very powerful language available for hands-on use, especially for the scientific community. Its BASIC performance isn't as good as ours, and its peripheral capability is rather limited, but the APL really grabs us."

Withington generally agrees, but doesn't restrict APL usage to scientists and engineers. "There are a lot of business people—planners, economists, statisticians—people who don't consider themselves computerniks at all, who regularly use APL and think nothing of it. This number is rapidly increasing, and IBM recognized it. Hence the APL."

What the future holds . . .

Initial IBM product announcements have a way of changing given time, and user and competitor inputs. As pointed out by a Digital Equipment Corp. source, "There's a tremendous gap between the System/32's base price of nearly \$40K and the top end of the 5100's top of \$19,975. Certainly additional models will probably fill those gaps." Indeed, this might be the most interesting aspect of the 5100. For if enough users bemoan the initial product's lack of disc storage, or its relatively primitive communications, perhaps IBM will respond with additional versions of the 5100. And while the 5100 might more closely resemble a programmable calculator than a full-fledged computing system, it would certainly suffice the dp needs of many small businesses, providing they have the necessary software written for it. After all, as one computer expert put it best: "The lines that have distinguished calculators from computers are getting very, very blurred." *

Your real time software is no place for INSECTUS-PROGRAMMA.

Insectus Programma, more commonly referred to as software bugs, can cost you money. These pests eat away at your profits and productivity by causing program development delays and costly system down-time. Not to mention the inconvenience.

The only known cure for Insectus Programma is time. Over a period of years, virtually all bugs can be removed from a software system; but how can you afford to wait that long?

When we designed the new SEL 32 minicomputers, we included the most extensive, reliable line of software available...software originally developed for the SYSTEMS 85/86 computers.

What does that mean to you? Plenty!

It means that you'll see big cost savings, through quicker application implementation and increased programmer efficiency. That's because our software

is virtually bug-free, completely documented, and fully supported. It got that way through five tough years in the field in hundreds of applications.

It means you don't have to worry about obsolescence. That's because SYSTEMS 32 software has a true 32 bit heritage, flexible enough to meet your future needs. The nucleus of our flexibility is provided by our powerful, disc-based Real-Time Monitor, a true multi-programming operating system.

Whatever your needs, we have the solution, like the extended FORTRAN IV Compiler, Process Control Executive...and a Terminal Support System that provides comprehensive services for multiple terminal users.

If Insectus Programma is bugging you, put it on the endangered species list...look into the SEL 32 Minis.

SYSTEMS
ENGINEERING LABORATORIES

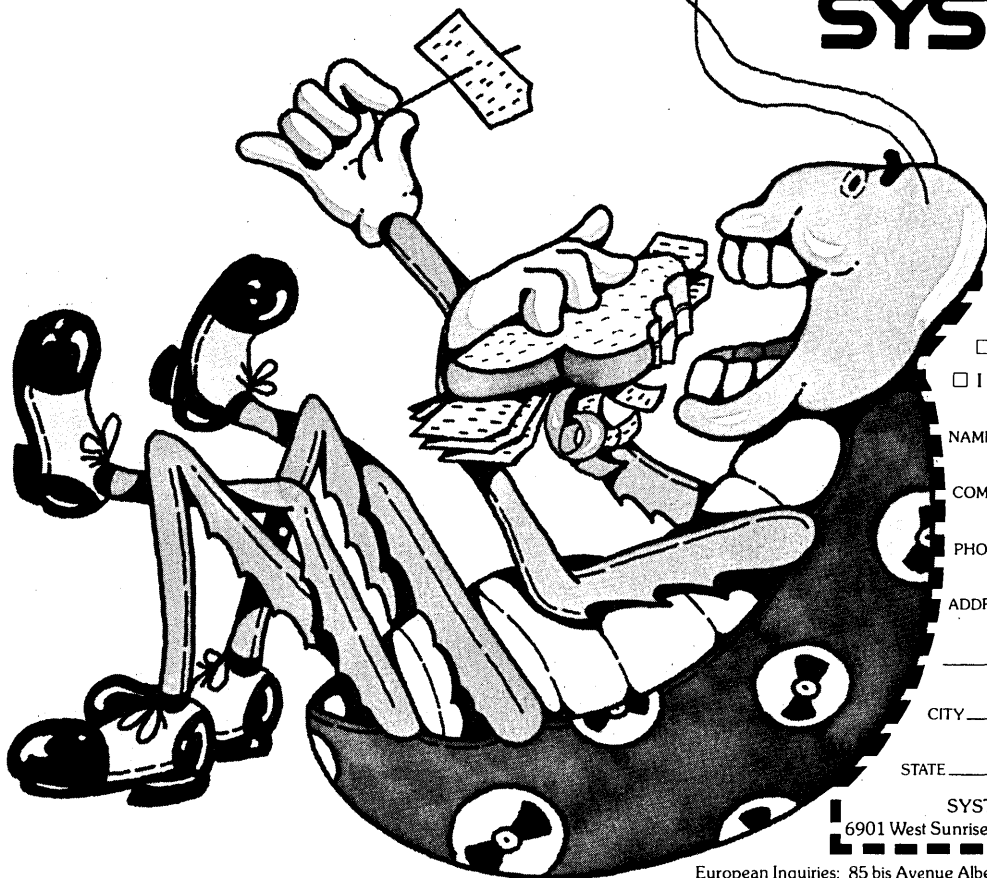

- CALL ME
- SEND ME MORE INFO
- I HAVE PRESENT NEED FOR SYSTEM

NAME _____

COMPANY _____

PHONE _____

ADDRESS _____

CITY _____

STATE _____ ZIP _____

SYSTEMS Engineering Laboratories
6901 West Sunrise Boulevard Fort Lauderdale, Florida 33313

European Inquiries: 85 bis Avenue Albert ler 92 Rueil-Malmaison, France Tel 967-8317

Interdata announces minicomputer EASYWARE.

Interdata and Megamini are trademarks of Interdata, Inc.

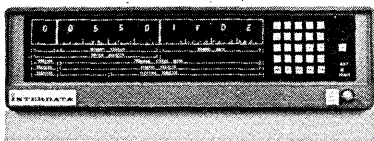

Interdata's 7/16 minicomputer is a 16-bit machine that combines high-performance with low cost. Its architecture, packaging and programmability make it a proven, cost-effective solution for the OEM buyer.

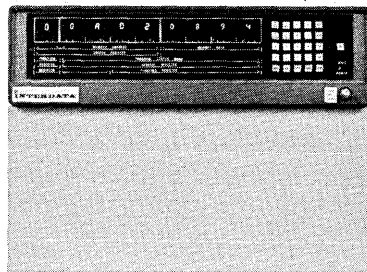

Interdata's 7/32 minicomputer is an economical 32-bit machine with a main memory expandable up to a directly-addressable million bytes of 750 ns core.

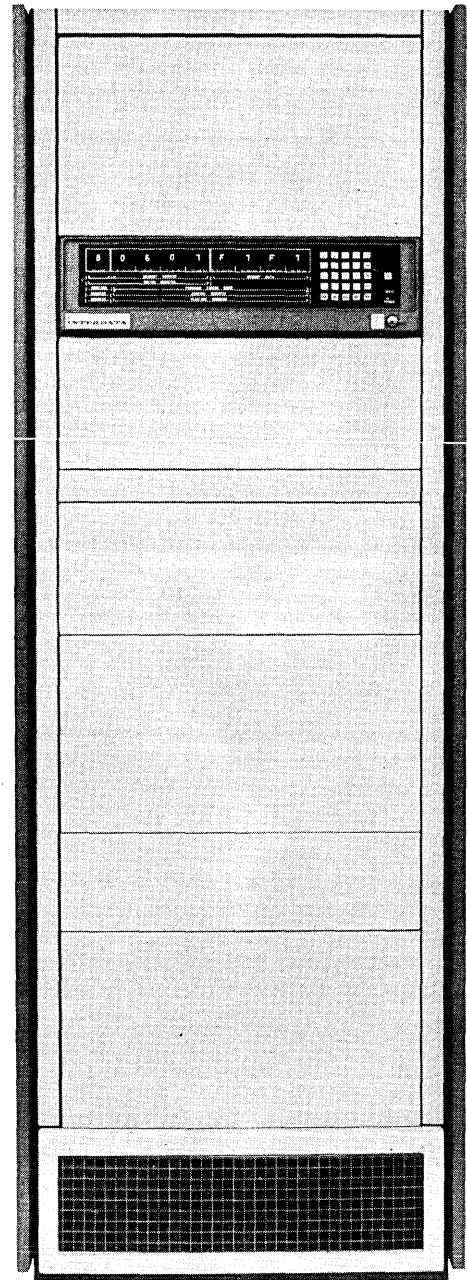

Interdata's 8/32 Megamini is the industry's most powerful 32-bit minicomputer. It is an unequalled combination of power, flexibility and reliability compactly packaged.

A family of hardware and software that's easy to work with.

Interdata offers a family of 16- and 32-bit hardware and software designed to be compatible throughout—from the low to the high end of the product line. Our Common Assembly Language enables you to go up or down in performance ranges always knowing your Interdata software will work.

Hardware.

From the beginning, Interdata built its minicomputers with a microprogrammed architecture, using the same architectural principles as the companies who build large-scale machines. As a result, our big machine architecture offers you 360/370-like instruction sets. Multiple registers. And the ability to scale-up from our 16-bit minicomputer to our one-megabyte, 32-bit Megamini.

With Interdata comes component compatibility which minimizes your inventory and guarantees interchangeability. Whether you use a 7/16, 7/32 or 8/32, you get the same front panel, power supply, memory, and same family of peripherals. Also, when you choose Interdata hardware, you can be sure anything you buy from us today is compatible with what you bought from us yesterday—or will buy from us tomorrow.

Plus software.

Interdata makes operating systems for the systems builder. Not only do they take advantage of the hardware, but they optimize the use of systems software and the human user. In addition, both the 16-bit OS and the 32-bit OS are completely compatible at all user interfaces—namely, file structure, supervisor calls, operator commands, etc.

To help the user build his system, Interdata offers a variety of higher level languages. These include: FORTRAN V—a very well-known version of FORTRAN extended for system construction. MACRO CAL (Common Assembly Language)—a macro-assembler which guarantees application program compatibility across the family. And BASIC—a simple, easy-to-use language.

Equals EASYWARE.

Interdata's philosophy has always been to make the hardware—the least expensive part of a minicomputer system—work the hardest. Our software then provides the tools which make it easier for you, and your people, to use our systems to solve your automation problems.

That's why we call it EASYWARE.

**INTERDATA®**

Subsidiary of PERKIN-ELMER

Oceanport, N.J. 07757. (201) 229-4040

6486 Viscount Road, Mississauga, Ontario, Canada L4V 1H3. (416) 677-8990 • Arundel Road, Uxbridge, Middlesex, England. Uxbridge 52441. 8000 Munchen 71, Forstenrieder Allee 122, West Germany. 089-75-30-81. • 92 Chandos Street, St. Leonards, Sydney, Australia 2065. 439-8400

Word Processing at Dun & Bradstreet

by J. M. Gaudette

A company which has been in existence over 130 years looks to the bicentennial year for the inauguration of its 80-computer distributed word processing network.

Since its founding in 1841, Dun & Bradstreet, Inc. has been engaged primarily in providing business information services to its subscribers. As part of its regular service, reports on individual businesses have been written as requested and a compendium of selected information from all reports has been developed and published six times a year (*The Dun & Bradstreet Reference Book*). In recent years the firm's Marketing Services Div. has also made use of the data collected in its market research.

The business reports vary in length from 1-30 pages, and include such information as financial statements, payment record, the history of the business and its management, and operations performed. These reports have been maintained on paper at D&B's local offices. Some data elements from the reports have been manually coded and maintained on mag tape files for the computerized marketing and credit reporting services and for reference book photocomposition. This amounted to about three million records.

For the most part, the report publishing part of the business has been off-line, but it is now in the process of changing. In 1970 a multiphased project was started with the ultimate goal of computerizing the file maintenance and reporting operations. When completed, the Advanced Office System (AOS) will be one of the nation's largest distributed intelligence networks, with minicomputers in more than 80 offices linked to two Xerox Sigma 5s and four Sigma 9s in northern New Jersey.

The network will put 15 billion bytes of data on-line to 1,200 crt terminals, and service almost 150,000 transactions daily. Also, the center will print

and mail about 400,000 pages of reports daily.

The first phase of the project, called the Advanced Local Office (ALO) system, has been completed. ALO is a word processing and remote data entry system. Its objective is to collect the business information in the field offices in a format that can be used to load the business information file when it comes on-line in 1976, while at the same time realizing some of the economies available from the word processing techniques developed for AOS.

Distributed processing

Business information is collected and updated by a staff of 2,000 field reporters who record it on coded forms (Fig. 1). The forms are reviewed for completeness, grouped into work batches, and then passed for data entry into a local computer system typically consisting of:

- Quotron Systems 801 with 48-64K words of memory. (The QSI 801 is a 16-bit word machine with a 750nsec cycle. It has 4 general registers, 32 indexing and storage registers, and 8 direct memory access channels.)
- 5-24 crt terminals (displaying 10 lines of 80 chars)
- Data Products 2310 line printer
- Hewlett-Packard 7900A system with 5MB of disc storage
- 35RO Teletype
- ICC 24LSI modem with auto-answer.

Turning down text editing

At the start of the AOS project, some of the first design questions were the definition of the data base structure and of the business report generation. Several text editing systems were reviewed; however, they were generally oriented toward composition. They

lacked a strong data coding structure, and one of the prime objectives of AOS is to collect the information in a way that provides specific identification of the data and allows flexibility in the output content and format.

A series of reporting forms were developed. The reporter enters information in spaces or check-boxes which have code identifiers associated with them. The forms are divided into code sections which combine logically related fields. Codes may be one or two character identifiers and may have fill-in fields terminated by an asterisk.

The data entry operator enters the codes into the local computer system where they are stored for processing. The information is subjected to machine validation; errors may be immediately corrected or held for subsequent recall and correction. One of the main functions of the system is the formatting of the codes into one of 34 possible report types. This formatting structures the data for printing and adds text constants as required; the ratio of the formatted output text to the coded input data runs about 1.75 to 1.

The reports used to be retyped for each revision. In today's ALO environment the completed report is still entered. But when the complete AOS system comes on-line in 1976, previously entered codes will be displayed at the local office and updated there. Since only corrections or updates will be entered, the input requirements will be further reduced.

Word processing for input

The data entry operator enters a continuous string of characters representing section identifiers, field identifiers, and fill-in data. Section identifiers,

important reference points for string operations, are bracketed by the characters < and >. These, in addition to the asterisk, may not appear in data fields.

An example of the code structure appears in the next column.

Data entry is independent of crt screen formats. Section strings may fill more than one display or may only partially fill one. And sections may be entered in any sequence.

A correction mode is available that allows direct access to any report data code. A complete set of cursor controls and string edit functions are available on the terminals which allow the insertion, deletion, or change of data. The modified sections may be longer or shorter, and new sections may be added. During both entry and correction the report data is "locked" so that it may not be accessed simultaneously by any other terminal.

Data entry is a straight typing job for crt operators. As suggested earlier, the entry of the data as a continuous string was found to be superior to the fill-in template technique traditionally used with crt's. The operator is not required to continually shift eye focus from investigating form to screen, but rather may remain focused on the form while keying, similar to a normal typing operation. A cursor return is automatically issued by the system at line termination so that the operator may key continually until the screen is filled, approximately four minutes

(720 chars). An audio signal is issued at each keyboard as characters begin entering the last line. Another advantage of this entry method is that the operator is independent of the system response time that would be required to select and process the fill-in templates.

The word processing functions have been in operation for over a year and a standard of 12,000 strokes per hour has been established for the operators. When coupled with the report formatting expansion ratio of 1.75 to 1, the effective keying rate is over 300 chars/min.

Before ALO the typing job had a high employee turnover rate. Because training required knowledge of the many report types and the various tab and format rules required in the manual system, it took several months for a new typist to reach full production. Since the report format rules are now

training mode program is available which accepts only correct entries from a group of special investigating forms used for training. This, together with tape instructions and a step-by-step training manual, allows new operators to reach full production in a few weeks.

Code processing for output

After defining the data coding structure, the next objective was to develop a technique for transforming the codes into a properly composed report. A prime consideration of the design was flexibility, as the reports are subjected to continual review and adjustment of their content and format. A second consideration was the need to do this transformation on more than one type of computer, yet keep the outputs identical, and implement changes simultaneously.

To accomplish this, a report generation system was developed consisting of a high-level report generation language, which specifies the report content and format, and the machine oriented processors that translate the language into tables. The tables are then used by an interpretive system that transforms the coded data into the appropriate output format.

An example of the output formatting is shown in Fig. 2. The format rules are defined in a series of tables which are interpreted by the report generation processor. These tables contain section code descriptions, format

```

<WAA> bad063917975*GJ001*L090974* <GAA>
A5211*bJohn Doe Co*cRetail Lumber
Plumbing Supplies*d1973*e52 21*fDoe
Plumbers Supply*s1119 Springfield Road*
wAny Town*xN. Y.*y05123*z914 964-8500*
<SAA> cdj140,000*k47,148*FNUZ...
  
```

defined in the system, operator training time has been cut to less than one-quarter of the time previously required. To assist in the training, a

Fig. 1. In interviewing company executives, D&B reporters or correspondents fill in lines and check boxes on forms such as these. The coded data is picked up by the data entry operator as a continuous text string.

```

<WAA> bad063917975*GJ001*L090974* <GAA>
A5211*bJohn Doe Co*cRetail Lumber
Plumbing Supplies*d1973*e52 21*fDoe
Plumbers Supply*s1119 Springfield Road*
wAny Town*xN. Y.*y05123*z914 964-8500*
<SAA> cdj140,000*k47,148*FNUZ...
  
```

Fig. 2. Report generation is basically the reverse of data entry, although a bit more complicated due to the merging of information and the variable report format. The codes are expanded to meaningful text by the local Quotron 801 system.

Somebody goofed!

The story of a calculator that doesn't do everything it was designed to do.

50,000 UNITS LATER

After 50,000 intergrated circuits (the heart of the calculator) were manufactured by a world famous CHIP manufacturer, someone discovered an error in the algorithm program. This is the mathematical formulas electronically built into each intergrated circuit. This error is ONLY apparent in calculating the arc cos of 0 however, and none of the other functions were affected. Rather than discarding these 50,000 chips, a quality calculator manufacturer, MELCOR, decided to take advantage of the situation. After all, not everyone needs the arc cos of 0. (By the way, NEW chips have since been made by this chip maker and are now available in calculators retailing for \$99.95.)

THE CHIP ERROR AND WHAT IT CAN DO FOR YOU

For a limited time, Chafitz is offering what is sure to be a first in the calculator field. A limited quantity of quality calculators with a CHIP ERROR. Due to this chip error the MELCOR 635 is not able to calculate the arc cos of 0 (which everyone knows is 90 degrees). But, at our unbelievable low price, who cares about the error. Just remember that the arc cos of 0 is 90 degrees and you've got a perfect calculator at the incredibly low price of only \$59.95.

LOOK AT WHAT YOU DO GET

A 40 key calculator with 23 functions • 8 digits with scientific notation • Two levels of parenthesis • Algebraic logic • e^x , $1/n$, 10^x , \log , SIN, COS, TAN, \sqrt{x} , x^2 , $1/x$, $n!$, y^x , π • Radian and degree calculations • Arc SIN, COS, TAN • 3 button accumulating memory • Register exchange • Sign charge • Rechargeable, with NiCd batteries included • Plus much more •

Accessories included: A/C adapter/charger, leather case with belt loop, instructions. Also, one year parts and labor warranty.

0 1/4 x 3 3/8 x 1 1/2

For the scientist, student, mathematician, engineer, businessman!

\$59.95

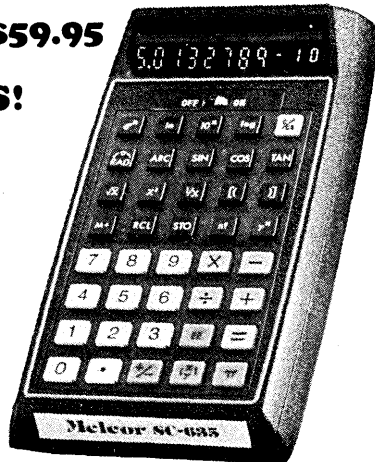

LIMITED QUANTITIES!

Due to the amount of machines produced we will have to fill orders on a first come first serve basis. So hurry, you don't want to goof by not getting one of these incredible machines!

10 DAY NO RISK TRIAL

If you can't believe this offer, try the calculator for 10 days in your home or office. If you feel it doesn't do everything we say it does, return the complete package for a prompt refund.

Remember, you can't calculate the arc cos of 0. But at \$59.95 who cares!!!

WHEN YOU THINK
CALCULATORS,
THINK

Chafitz

856 Rockville Pike
Rockville, Maryland
20852

559

AMERICA'S CALCULATOR
COUNSELORS™

MAIL ORDERS ACCEPTED

Add \$2 per unit when ordering
Maryland residents remit 4% sales tax.

ORDER NOW BY PHONE

800-638-2997

Maryland residents call: 301-340-0200
Operators on duty Mon. Sat. 10-5 EST

MAJOR CREDIT CARDS ACCEPTED

CIRCLE 81 ON READER CARD

WORD PROCESSING

instructions, and text constants.

The language is machine independent (and has, in fact, been implemented on three different computers). This independence provides consistency among the different systems that will be formatting reports in AOS. The implementation of changes in format specifications and the addition of new reports is simplified; the rules are developed once in the report generation language and then compiled for the different computers. The new tables may then be transmitted to the local office computers as a file update.

As noted in the previous section, the report coding results in the entry and collection of data elements that are specifically identified and that may be accessed individually. The content and format relation between the input data and the resulting report is contained in the report generation tables. This provides a great deal of flexibility in the development of printed or visual reports from the system.

In ALO, report generation produces a locally generated report which may be either printed on an offset master or displayed on a crt. (Under AOS most report generation, at least for updates, will be done at the central site.) When displayed, the operator may either page through the report, or selectively go back and forth among the various areas of information (e.g., Finance, Operation, or History).

Data validation

The coded report data is checked for field legality and consistency. The validation rules are described in a user oriented data validation language that is similar in structure and concept to the report generation language described previously.

The language specifies:

- valid report types
- valid sections by report type
- valid fields in each section, and their characteristics
- logical relations among fields, both intra and inter-sectional
- logical relations among sections
- non-standard validation subroutines which may be "plugged-in" for specific fields or field combinations.

The standard field characteristic checks include length, data type, and repetition. The logical operations allow any combination of IF/THEN, AND, OR, XOR, and NOT to any depth required. The rules are developed in the user oriented, nontechnical validation language and then compiled into tables used by the validation processor.

Validation is invoked for both entry and correction. The validation is performed at the end of a report unit

20 million microfiche in 4 years.

Four of the hardest working Bruning duplicators we know of belong to Disclosure, Inc., in Bethesda, Maryland. In their mainstream business, this micro publishing firm produces quantity fiche copies from documents filed by companies with the Securities and Exchange Commission.

Three Bruning OP40s and an OP49, each with an automatic collator, produce 4 to 5 million fiche duplicates a year; or, 20 million

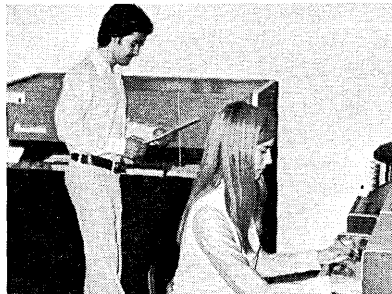

in 4 years. That's about *double* the industry's average output from high-speed fiche duplicators. During peak seasons the units produce over one million duplicates per month.

Now, if you're thinking about a microfiche duplicator for your operation, all we ask is that you consider Bruning's proven capacity for endless hard work in making your buying decision.

Contact your local Bruning office for more information. Or write Bruning, 1834 Walden Office Square, Schaumburg, Illinois 60172.

The bold force in micrographics.



BRUNING

DIVISION OF
® ADDRESSOGRAPH MULTIGRAPH

*This ad
may start
a love affair*



Meet Trendata's beautiful new Model 4000 Data Communications Terminal

You're sure to fall in love with the 4000's elegant blend of optimum throughput and whisper-quiet production. You'll appreciate the economy of a terminal so easy to use that costly special training is no longer needed. And your operators will relish its human-engineered comfort.

- Electronic, Selectric-style keyboard with tactile response generates full ASCII character set.
- 30 cps printer with snap-on type fonts gives superb print quality.
- Wide range of options includes tape storage, plotting, unattended operation, switchable baud rate, selectable pitch, red ribbon shift, and built-in modems.

Call or write for details.

trendata
An Applied Magnetics Company



610 Palomar, P.O. Box 5060,
Sunnyvale, CA 94086
(408) 732-1790

WORD PROCESSING

rather than during entry. At this point it does not interfere with the keying pace, and comes at a logical break in the entry dialogue. Whatever the sequence of entry, the sections are validated in a sequence that is natural for the report type being entered.

The errors that are detected may be either data entry keying mistakes or data content errors originating on the investigating form. Whenever an error is detected, a diagnostic message and the section in error are displayed, and the system enters the correction mode. The operator may either correct the error or, optionally, file the data with a "Not-Valid" status. The latter option is taken when the error originated on the source document and it must be passed for correction.

The crt terminals may perform any function at any time. The coded report data is accessible and may be displayed either directly or as a formatted report. A security function is available, however, that allows the restriction of functions to designated terminals and operators. All functions may be protected by a password.

Work-in-process lists are available in either geographic or alphabetic sequence, or by work batches. Reports may be moved from one work batch to another, and batches or reports may be selectively deleted.

A mini for communications management

After a final accuracy check, "approved" reports are passed for duplication, distribution, and filing, and the coded data is queued for transmission to the national center where it is accumulated on tape to build the data base. In addition to report data, administrative messages may be entered for delivery to any one or a combination of the offices in the network.

Every 20 minutes the network managing computer dials each office via one of ten WATS lines. The local computer automatically answers the call and, during a typical five minute connect time, transmits and receives administrative messages for local printing on the Teletype 35R0, and transmits approved reports. A BSC communications protocol is followed in transparency mode, at rate of 2400bps. The network daily volume now averages 35,000 interoffice messages and more than 20,000 reports.

The central qsr801 also manages 16 leased lines and acts as the network managing computer for a Xerox Sigma 5 message switch. The 801 passes all traffic to the Sigma for routing of administrative traffic and accumulation of reports on magnetic

tape. The message switching software in the Sigma 5 is based on the system formerly used to manage the low speed network using tty 28ASRS which was replaced in all but 16 offices by other qsr801s, crt's, and dial-up lines. While upgrading the message capacity and allowing for the increased data transmission volume, it reduced communication charges by substituting the WATS lines for the low-speed, leased network.

Conclusion

While the ALO applications software represents approximately 30 man-years (and includes over 80,000 instructions), it represents only a small portion of the effort and cooperation that was required to implement the system. ALO has impacted every field office of Dun & Bradstreet, Inc., and it required the training of more than 600 employees spread across the country. The system implementation required the coordination of software and hardware delivery, and employee instruction. An installation team was assembled by the field operations management to prepare each office for the system and to begin the training program, and a field engineering group was developed to support the field, coordinate delivery schedules, and solve operational problems. In all, over 100 people in five separate organizational groups cooperated in the development and implementation of ALO.

The ALO system represents a first step in an orderly transition from a decentralized manual system to a fully integrated nationwide system. Although this word processing system was specifically designed for Dun & Bradstreet, the basic concept and design may have application to other areas which require a flexible data collection, report generation, and remote data collection. *

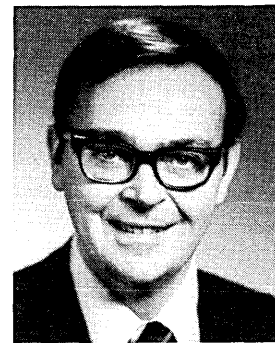

Mr. Gaudette is the manager of product planning and development for Dun & Bradstreet, Inc. He started with D&B in 1961 as a reporter, became a programmer in 1968, and joined the AOS project in 1970. He also was project manager for the ALO software system.

**THE
UCC GENERAL
LEDGER/FINANCIAL
CONTROL SYSTEM:**

1. Single and complete financial data base.
2. Flexible data entry.
3. Unique automated system interface.
4. Authentic data base design.
5. Currently operational: 360/30 DOS to 370/168 OS/VS and mid-size Burroughs.
6. Backed by the leading software company—UCC.

Then talk to UCC. Our General Ledger/Financial Control system is the most complete accounting and management reporting system available. That, along with the support that comes with it, is why over 150 successful installations have been made.

Mail this coupon or call Richard Steller at 214/637-5010.

- Please send me more information:
 Have someone call me about:
The UCC General Ledger/Financial Control System.

Name _____

Title _____

Company _____

Address _____

City/State/Zip _____

Telephone _____

Mail to UCC Financial Software
P. O. Box 47911
Dallas, Texas 75247
Or call Richard Steller
(214) 637-5010

DM 1157



**Show
this to
the next
guy who
tries to
sell you
financial
control
software.**

UCC

UNIVERSITY COMPUTING COMPANY

7200 Stemmons Freeway P. O. Box 47911 Dallas, Texas 75247
A Wyly Company

When Not to Use a Data Base

by George Schussel

Data base technology is too complicated and expensive a tool to use for all applications.

Without any question, the use of data bases and data base management systems (DBMS) has been a primary trend in dp shops since 1970. Along with the technologies of minicomputers and communications, data base has become one of the three major differences separating the decade of the '70s from the '60s.

There also is no question that the use of data bases has come a long way in the last five years. As recently as 1970 there were about 100 users of DBMS in the U.S. In 1975 one can add up the number of installed customers of major packages such as IMS, TOTAL, IDMS, ADABAS, SYSTEM 2000, DMS1100, and IDS, throw in home-grown DBMS, and conclude there are around 3,000 users of data bases and associated DBMS in the U.S.

Not only is there tremendous interest in the subject, but some people are comparing the impact of data base on dp in the '70s as being analogous to that of COBOL in the '60s. At the start of each decade, each respective concept was only an idea where by the end of the '60s, COBOL had achieved the status of de facto standard within most shops, and data base well might by the end of the '70s.

Truly, there's a bandwagon effect. Who wants to be left behind with obsolete technology? Well, it seems that many are finding out that tape processing on sequential files is not obsolete, and will remain an important mainstay of the dp shop for many years to come. While it is certain that the data base approach will become a standard in most shops, it is equally certain that many people have made the data base decision for the wrong reasons; the remainder of this article points out some good reasons why you should consider *not* going to data bases at this point in time.

Data independence

The primary rationale for the data base approach is its facility for data independence—in other words, the di-

vorcing of the description or definition of data from any individual program, thus allowing multiple users and programs to access the same data files without undue difficulty. Since that is the primary reason for installing a data base management system in the first place, then the converse should also be true: for anyone who does not need data independence, there certainly is less rationale for going to data base.

It is easy to think of applications where it is desirable for many programs to have access to the same data. In the insurance industry, for example, systems and the data files to support those systems tend to be highly integrated. The data base approach offers a wealth of advantages by eliminating redundancy and/or awkward construction of systems to achieve the goal of multiple uses of the same data.

On the other hand, it is more difficult to think of an environment where there is little or no desire for data to be shared among users. However, consider for example a service bureau environment in which computer time is sold to many small users who access their own individual files for research and problem solving. If the individual users do not want to share information in their files, there is little need for the data base approach.

Sequential processing

Since tape drives were delivered on the UNIVAC I and on practically every general purpose medium-to-large scale computer built since that time, most data files have been built around the use of tape as a basis for organizing information. Tape is inexpensive, does not have to be kept on-line, can be passed at very high speed, and is ideally suited to handle large volumes of data.

However, the only practical way to handle information on tape is to store it sequentially. Sequential storage and accessing tends to be pretty good for some applications, but extremely bad for others. Tape is good when you have a relatively high hit ratio. Various

studies (see for example William R. Charles, "Some Systems Shouldn't Use Chained File Techniques," *Data Management*, Sept. 1973, pp. 33-37) have shown that whenever you are passing a file with a hit ratio of more than 4-6% of the records, then a sequential based organization is probably the most efficient. (If you are hitting on a very small percentage of the records, some sort of "random" access methodology on disc is to be preferred.)

If the primary consideration is speed of processing, and the hit ratio is over 4-6% consistently, one should then want to stay with tape files and sequential organizations. As the hit ratio rises, the advantage of tape over disc goes up dramatically.

Another reason for staying with tape-based processing is when there is no current or foreseeable need for on-line access to your files.

Tight security requirements

Most DBMS come with some type of privacy or security mechanisms. CODASYL systems use the subschema approach to implement data security, while other systems use passwords or other lockout mechanisms.

Nevertheless the most secure data is located in a locked safe and only mounted when runs require that data. If you need this much security in handling your data, then the multiple user and data independence advantages of the data base approach do not buy you much. Most DBMS have privacy mechanisms that are entirely satisfactory for the normal business dp environment including manufacturing, insurance, banking, distribution, etc. However, if you're the CIA, think twice before you install a data base system!

Can't afford more hardware

There is no question that the data base approach will put a heavier load on your computer than was previously there. This becomes obvious when you measure cpu utilization and main

(Continued on page 91)

WHEN NOT TO USE A DATA BASE

memory requirements in shops that have installed DBMS. For example, it is not unusual to find an IMS shop with 500KB of real main memory devoted to IMS alone. Although IMS requires more real main memory than other popularly installed DBMS, all such packages will consume some real main memory.

Also, because the functions of a data base management system are central and housekeeping in nature, it occupies resources in the computer comparable to those of the operating system. As a result, even on machines like the larger powerful 370s, cpu utilization goes up substantially after installation of a DBMS.

In addition, the data base approach strongly implies the reorientation of your data files from tape to disc. Disc is substantially more expensive for storage than is tape; and, if you're putting all of your files on-line to a DBMS, you'll need to upgrade disc capacity substantially.

Hardware is not too reliable

High reliability of hardware and software is absolutely crucial to the successful installation of a DBMS. One nice feature of tape-oriented processing is that as an automatic byproduct of normal processing modes, backups are created. When one updates a tape file, he does not write over that tape file, but creates a new masterfile. The backup then is the previous generation tape masterfile plus the transaction file which was processed against it. Thus whether you want it or not, you have an efficient backup scheme when you're processing in a tape-oriented environment.

This is not the case in disc-oriented data base processing since you are writing over the individual records in your data base as you are updating. While a number of vendors have come up with a successful warm restart, roll back, and roll forward recovery procedures for their data bases, implementation of these facilities does require analysis and thought. A failure in any of these facilities can result in substantially more problems for the user than he would likely encounter in a tape environment.

Current investment

When the IBM 360 was announced, emulation of programs written for older machines was a key selling point. However, once the realities of the third generation became known, it was clear that emulation carried a heavy price—substantially more hardware! If one wanted to control hardware budgets and at the same time have maintain-

able programs, the right answer for many shops was simply to close down the programming section to any new requests for one or two years until all of the old programs were rewritten into COBOL or another third-generation language. Where this happened, and the result was well-documented, well-running, easily maintainable systems, then it certainly seems that any proposal to move to another dp concept would have to be suspect.

In any move to data base, a primary candidate should always be that system whose time has come to be replaced because it has been patched to death. Once you've made a decision to upgrade and replace a system anyway, then why not do it using the latest technology—data base? On the other hand, if you've already replaced the out-of-date technology and you're living in a satisfactory environment, then the advantages of the data base approach had better be substantial for justification.

Not yet a standard

Even though CODASYL, the same group which was largely responsible for the development and standardization of the COBOL language, has been actively involved in the data base approach since the late '60s, the urgency of developing a standard for DBMS has not yet taken on the stringency of the COBOL standard in the '60s.

Although over one half of the different DBMS being marketed are exact or close implementations of the current CODASYL Data Base Task Group recommendations, this number is a little deceiving, since most of these CODASYL implementations are relatively recently announced packages, and also are for equipment other than IBM. (The only widely used DBMS for IBM equipment, which is an implementation of the CODASYL specifications, is Cullinane Corp.'s IDMS.) Because the older DBMS were written before the CODASYL specifications came out, the vast majority of all DBMS installations, with systems such as IMS, TOTAL, and IDS, are not CODASYL implementations.

An important question, therefore, is will there ever be national or international standards? Does the American National Standards Institute have any plans for adopting the CODASYL standards? And, if ANSI does adopt this standard, will the various vendors move to it?

If there is a national standard, it will probably be promulgated by ANSI and be either exactly the CODASYL standard, or a variant of it. If there is to be no standard, then there is no reason to hold back from implementing a DBMS. But a move to a standard DBMS from a non-standard one will involve a conversion comparable to that from DOS to OS.

The first move into any new technology necessitates many one-time costs which are very difficult to recover on the first application. With data base, the first application will require either purchase or lease of software not previously used at the installation. The popular DBMS packages license for anywhere from around \$30,000 to \$160,000. In addition there will probably be a need for additional hardware—especially in main memory and disc, as discussed above.

There will also be the necessary time investment in experienced personnel to acquaint them with the data base approach. (Two to four weeks for competent coding of simple reports, and from four to eight months for a good overall knowledge of the DBMS). Initially the team will have to analyze packages and subsequently learn the techniques of building a data base system with all of its associated technologies such as data dictionaries, data base administration facilities, etc.

Given the significance of these investments, it cannot often be argued that the first data base application will save your company any money. Almost always the payoff comes in later applications as advantage is taken of the elimination of data redundancy, and as the better control that is inherent in the data base approach comes about. If the budget is ominously tight, however, second thought should be given before moving into a data base.

One of the cost aspects mentioned above, the training of personnel, can be expanded into a whole problem area of its own—the lack of adequate numbers of trained personnel. There currently is a large imbalance between a small supply and a large demand for trained personnel in data base technology. As long as the supply is substantially less than the demand, then companies will have to train their own personnel instead of going to the marketplace to hire experienced data base personnel. This is costly since training a senior systems analyst to become a data base administrator can consume six to nine months, plus the associated salary costs of this time. Concomitantly, the probability of losing trained individuals will also remain high as long as the supply and demand for personnel is severely out of balance.

Files being too large is one of the most fundamental reasons for avoiding the data base approach. This cost is also one of the easiest to calculate for your company. There is nothing inherent in data base about either the hardware or the software that limits applications to small files. On the other hand, as the size of masterfiles for the data base grows larger, the implement-

(Continued on page 98)

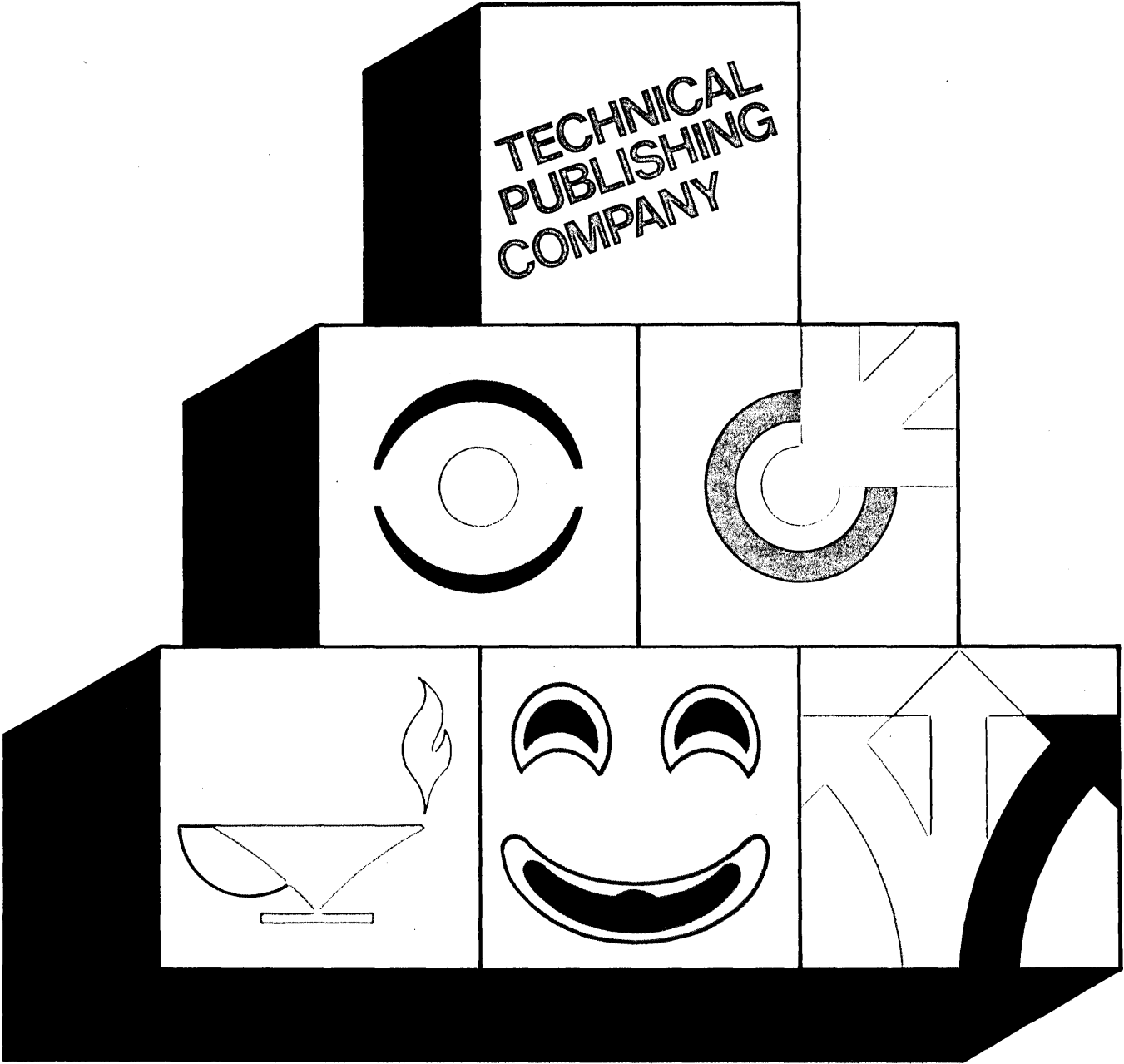

We're a lot more than our name implies.



INFORMS. More and more industry professionals look to Technical Publishing Company as their first source for technical and business information. Our seven national business/professional magazines—Consulting Engineer, Datamation, Plant Engineering, Pollution Engineering, Power Engineering, Purchasing World, and Research/Development help business leaders solve practical problems, keep up on current market trends and new technologies.



HELPS TARGET SALES. Our seven national magazines also enable business to pinpoint its selling message to the desired specialized market. Our target selling concept is so successful that six of our seven magazines were among the top 100 specialized business publications in advertising revenues last year.

Technical Publishing Company further helps business with its annual Plant Engineering Directory and Specifications Catalog, industry's prime reference source for product information, plus services such as specialized product postcards, circulation list rental, and market research.



TRAINS. Our TPC Training Systems are training badly needed maintenance craftsmen for industry through self-contained modular training programs geared to 42 specific subject areas. This proven

self-study systems approach is an effective solution to an industrial need. And the cost of TPC Training materials is about one-third the industry average.



ENTERTAINS. Our DBI Books Division (formerly Digest Books) entertains a growing leisure market with over 60 titles devoted to sports, hobbies, crafts, and nostalgia. In addition, millions of "Digest books" are sold to U. S. corporations for premium use and sales incentives.



GROWS. Technical Publishing Company is committed to growth, with specific programs and diversification goals. While the rest of our industry increased revenues by 6% last year, Technical Publishing Company showed a 13% gain. For 14 consecutive quarters, our sales and earnings have bettered those for the previous year. And for the first nine months of '75, revenues and profits have advanced over the same period last year.

Technical Publishing Company is publicly owned and our stock is traded over-the-counter. For information on any of our properties or the company, write James B. Tafel, President and Chief Executive Officer.



Technical Publishing Company
1301 South Grove Avenue
Barrington, Illinois 60010

BRIEFCASE PORTABILITY

Now you can have briefcase portability with Digi-log Interactive CRT Terminals. Control unit, keyboard, acoustic coupler, and 5" video monitor are all contained in one briefcase for maximum user convenience.

Call 215 672-0800

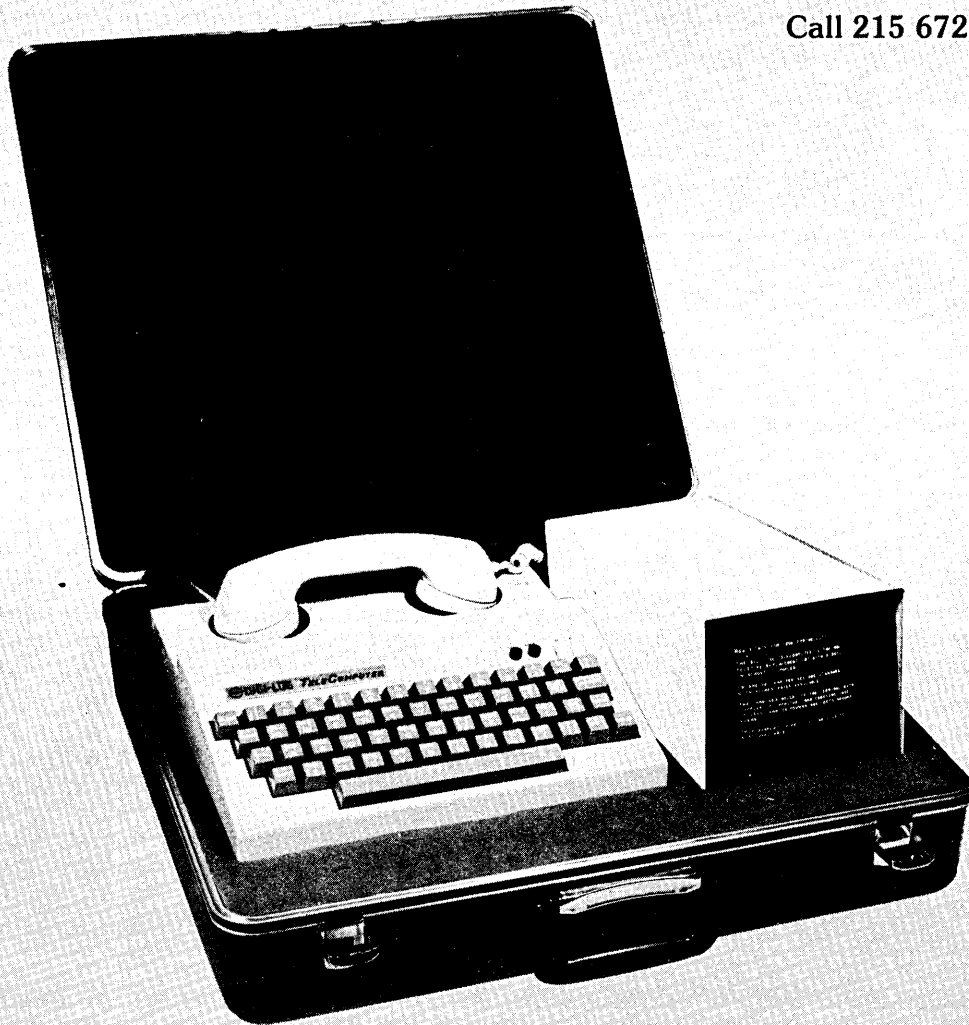

DIGI-LOG
SYSTEMS, INC
Babylon Road Horsham, Pa 19044



ASK CONTROL DATA for MOS Monolithic Memories for every IBM 370-135, 145, 155, 158, and 165.

WE HAVE IT.

With more installation and maintenance experience than any other independent!

CDC provides complete software compatibility, better maintainability, dedicated installation teams and total service support in its compact, energy-saving MOS monolithic memories.

	135	145 Mod I	145 Mod II	155	158	165
Graceful degradation	x	x	x		x	
Out of Bounds		x		x		x
Space Saving				x		x
Power & Cooling Savings	x	x	x	x		x
Leased memory for any purchased CPU's	x		x		x	

Control Data — the leading independent. It's been around a long time — and it'll be around for a long time to come. For further information, call your local CDC sales office, or CDC Hotline Collect (612) 853-7600, or send coupon.

T. E. Phillips, V. P. Sales, Peripheral Products Company
Control Data Corporation, Dept. D-115
Box 1980, Airport Station
Minneapolis, MN 55111

Name

Phone

Title

Company

Street Address

City

State

Zip

GD CONTROL DATA
CORPORATION

THIS CARTRIDGE IS UNUSUALLY PRECISE.
AT \$4400*, THE TERMINAL THAT ACCEPTS
IT MIGHT WELL BE REVOLUTIONARY.
INTRODUCING THE HEWLETT-PACKARD
2644A MINI DATASTATION.

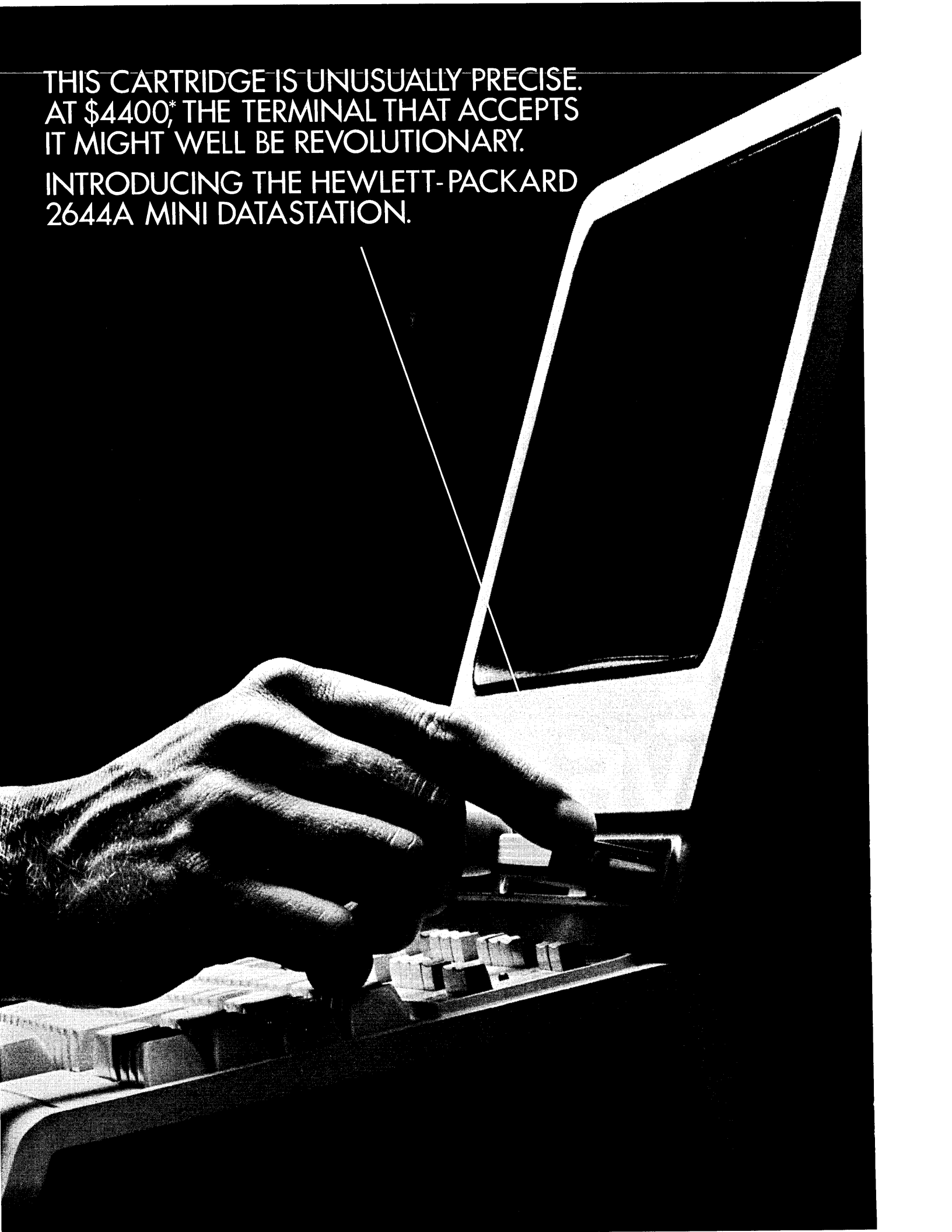

A NEW WAY TO STORE DATA CREATES A NEW KIND OF TERMINAL.

We've added twin-cartridge, integrated, local mass storage to the powerful interactive capabilities of our 2640 CRT. The result is the HP 2644A Mini DataStation, a new approach to data entry that allows many functions to be economically performed off-line that previously required costly computer time.



ENTER AND EDIT DATA OFF-LINE.

There's an enhanced 5" x 10" high-resolution display. Operator fatigue is reduced thanks to familiar-looking Roman characters delineated by a crisp 9 x 15 dot-character cell. Work proceeds efficiently with the aid of single key initiation of multiple functions, high speed search, character or block mode operation, off-screen line storage, a "protected data" switch and many other Mini DataStation convenience features.

110,000 BYTES IN EACH SHIRTPOCKET-SIZE CARTRIDGE.

That's enough for hours of typing. Precise engineering of the cartridge to HP specifications has resulted in the significantly low data loss rate of less than one byte in every 10⁸. Full-width, single-track recording guarantees that this unusually high level of performance is available at every Mini DataStation, everytime.

ACCURATE DATA ENTRY IS SIMPLIFIED:

By batch transmitting to the computer after data has been properly for-



*U.S. domestic price only, quantity six.

matted and edited, efficiency is increased, errors reduced and connect costs lowered. Correct data entry is easier, thanks to the DataStation's formatting and protected field capability. A choice of four character sets lets the operator select the correct written or graphic symbol instead of an awkward approximation. And, an optional "forms" mode allows all your company forms to be pre-programmed for near instant, error-free display.

"FAIL-SAFE" ON-LINE OPERATION.

Even in the event of a computer breakdown, there is minimal work load disruption or data loss. The Mini DataStation can function independently until the computer can be brought back on line.

POP-IN UPGRADES.

POP-IN MAINTENANCE.

Two latches provide access to every component. Want an added feature? Plug it in. Is there a new state-of-the-art option? Plug it in. Need a repair? Pop out the old. Plug in the new. There's even a built-in self-TEST key for an immediate go/no go verification by the operator.

HP TECHNOLOGY, A BARGAIN AT \$4400*.

The HP 2644A Mini DataStation represents significant increases in throughput, data accuracy and flexibility at a price that could revolutionize your terminal operations. It is built to HP's exacting standards, and backed by HP's reputation and worldwide network of sales and service offices. For complete details, call your local HP office, or write.

HEWLETT  PACKARD

Sales and service from 172 offices in 65 countries.

1501 Page Mill Road, Palo Alto, California 94304

Informatics PMI, Inc.

(a subsidiary of
General Telephone & Electronics Corporation)

has been acquired by

Informatics Inc.

(a subsidiary of
The Equitable Life Assurance Society
of The United States)

The undersigned assisted General Telephone & Electronics Corporation
in the negotiations which led to this transaction.

Salomon Brothers

Members New York Stock Exchange, Inc. / One New York Plaza, New York, N.Y. 10004

CIRCLE 100 ON READER CARD

When it comes to graphics: don't fake it! digitize!

The Numonics Digitizer makes it easy to turn strip charts, templates, graphs, even aerial photographs into good straight numbers. The Numonics Digitizer is desk size but big enough to offer a 24" x 24" work area. Economical, but with useful features like 0.010" resolution, a big display, and parallel BCD-buffered output.

All standard. Optional hard-wired area and/or length measurement, with or without scaling. We can also tailor our digitizer into a data handling system that's perfect for you.

Write for more information
The Numonics Corporation
Rte. 202 and Hancock St.
North Wales, Pa. 19454

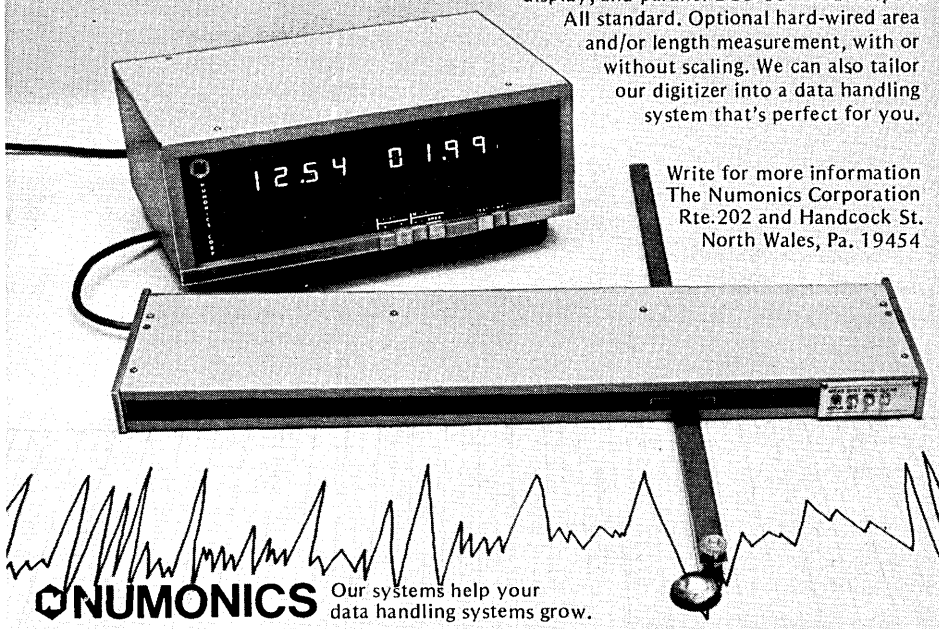

NUMONICS Our systems help your
data handling systems grow.

CIRCLE 94 ON READER CARD

DATA BASE

tation problems (schema generation, security, recovery, etc.) grow at least as fast as the data base size.

Most data bases that have been implemented in the U.S. have been in the range of under 100 million characters of raw information. Even today a data base of over 1 billion characters of information is considered very large. There are no more than a handful of such data bases that have been implemented.

In a typical data base environment, the disc overhead factor ranges from 100-300%. This means that 1 billion characters of raw data are going to result in a storage requirement of up to three times that much space—roughly equivalent to between 20 and 40 IBM 3330 devices. Can you convince management to have that amount of disc onsite? If not, and multiple data bases (without dynamic interaction) are not a good solution, then the data base approach would not be appropriate.

The insurance industry, for example, has moved slowly and surely, rather than by leaping, into the data base environment, and primarily because insurance files often run to over 1 billion characters. The associated hardware costs required to implement this data on disc has required careful analysis and slower than desired progress into the data base environment.

The data base approach is relevant and essential to data processing development during the remainder of the '70s and through the '80s. At my company, American Mutual Liability Insurance Co., we are moving slowly but surely into the data base environment. Careful consideration and analysis of the relative advantages and disadvantages of the data base approach is needed before hopping onto the data base bandwagon. *



Dr. Schussel is vice president of American Mutual Liability Insurance Co. where he is responsible for the company's dp activities. He received his doctorate from the Harvard Business School and authored a number of articles on data base and related topics.

DP Dialogue

Notes and observations from IBM which may prove of interest to data processing professionals.



An ETMF freight depot near Chicago at dusk.

IBM 3767 terminals are linked by a communications network spread through 19 states.

Freight Carrier Picks Up Speed with New Communications Terminal

It isn't every day a company installs new terminals throughout its operation, enlarges the scope of its communications system and projects a savings of some \$60,000 a year.

That's what's happening at ETMF Freight System of Dallas, where new IBM 3767 Communication Terminals have replaced the company's 2740s in 55 freight terminals around the country.

"Not only do the new hardcopy 3767s cost 24% less than the 2740s," says Tom Hendrickson, director of management systems, "but they can also print up to five times faster."

The 3767s are the latest addition to ETMF's online network, which uses the IBM Freight and Equipment Reporting System for Transportation (FERST/VS) for message switching and equipment control. At ETMF, the FERST/VS group of Program Products runs on a System/370 Model 145 linked to a communications network that connects the carrier's freight terminals.

This fall, the company expects to install the third program of the FERST/VS package—billing. "Putting the billing function online would have meant adding terminals to handle the extra workload," says Hendrickson. "But the greater speed of the 3767s means we will need fewer additional terminals to do the job. We figure the saving on machine replacement, plus the saving on additional machines, will add up to some \$60,000 a year."

The 3767 prints faster because it is a bidirectional matrix printer. Its built-in logic microcode determines whether it would be faster to print from left to right or right to left. It can also decide how best to move on to the next print position, say an indentation or a tabbed column, without any wasted motion. The result: the 3767 can print up to 80 characters per second.

"An inventory report can now be printed in ten minutes," Hendrickson says. "With the 2740, this job would have
(Continued on next page)



At the Penn State University test plot in Rock Springs, Pa., plant pathologists study conditions that cause potato blight.

Computer Helps Farmers Fight the Blight

Figuring out the best time to spray potato crops to prevent blight used to be largely a matter of guesswork. But for the past four years, more than 100 farmers from Maine to Florida have been getting valuable assistance in their battle against a lethal, blight-producing fungus from an unexpected source—a computer program known as “Blitecast”.

Developed and administered by plant pathologists at Pennsylvania State University at University Park, Pa., the Blitecast program predicts the appearance of the fungus seven to fourteen days in advance. Data for the program is collected with hygrothermographs and rain gauges, which monitor temperature, humidity and rainfall in each field on a daily basis. At the end of the week, growers telephone the data to researcher John Peplinski, who uses a typewriter terminal in his office to enter the information into the university’s System/370 Model 168. The data is analyzed against the conditions that are known to promote fungus growth—warm days, cool nights and extended periods of humidity exceeding 90%.

Within a few seconds, the computer prints out a recommendation indicating whether it will be necessary for the farmer to spray fungicide that week. “It used to be standard procedure to spray automatically once a week,” says Peplinski. “By using our program, many growers have cut their spraying schedules substantially, without sacrificing crop safety. At \$4 per acre for fungicide, farmers can save considerable money—and cut pollution at the same time—if conditions don’t indicate fungus growth.”

The computer can also produce a longer report that summarizes blight forecasts, weather conditions and spray recommendations made to date for each participant. A typical file extends for the duration of the potato growing season—generally from May through August.

In research related to the Blitecast program, scientists at Penn State are also studying the extent to which reduced concentrations of fungicide will effectively kill blight, and the precise relationship between weather conditions and tuber maturity. “Our goal is to increase crop yield by every possible means,” says Peplinski. “Using the computer is the only way we can get accurate predictions to our farmers quickly enough to be effective.”

Freight Carrier..

(Continued from preceding page)

taken almost half an hour.”

He points out that the faster printing speed means the machine is more available to receive reports and enter data. And getting more information more quickly means that ETMF is in a better position to assure on-time pickup and delivery. “Timely service is the most important product a freight line has to sell, especially since all rates are regulated by the Interstate Commerce Commission.”

Were the 3767s easy to install? According to Hendrickson, it was a “plug-in” situation for the most part. “We needed little help from IBM, and we were able to schedule installation when it was convenient for ETMF.” He goes so far as to say he can install a 3767 himself in 15 minutes flat. “Operators adapted quickly to the new terminals, and no training people had to be sent out to the field.”

The new machines have proved highly reliable. Based on Large Scale Integration (LSI) technology, they have

few mechanical parts to go wrong. Should any trouble occur, a built-in diagnostic capability alerts the operator and the problem can be isolated. Often this can be remedied on the spot . . . an important consideration in a small, remote freight terminal.

The new terminals have improved the productivity of the communications system at ETMF. They have also opened the way to growth, because they are compatible with Systems Network Architecture (SNA). “This combination of equipment and programs will simplify the connections among controllers, lines and terminals in our system,” says Hendrickson. In 1976, plans call for the installation of three components of SNA: Synchronous Data Link Control (SDLC), Virtual Telecommunications Access Method (VTAM) and Network Control Program (NCP).

“With these enhancements,” continues Hendrickson, “we will be able to increase transmission speed while continuing to give our users at remote terminals direct access to application programs in our central computer. In addition, we will be able to use many different kinds of terminals with varying functions within the network.”

“One of the sweetest systems in the industry”

That's the way Mario Calderin sums up his experience with the new IBM 3790 Communication System. Calderin is director of management information systems at Work



Mario Calderin

Wear Corporation's Rental Services Division. The Encino, California, company installed one of the first 3790 networks in the country. Running under IBM's Systems Network Architecture (SNA), the 3790 brings new data processing capabilities to the company's remote locations. At the same time, it streamlines the flow of information between the field and the System/370 Model 145 at the firm's central computer facility. Calderin was so enthusiastic over his early success with the 3790 that we asked him to tell the story in his own words.

What has the 3790 accomplished for your company?

“There are two major benefits that the 3790 is bringing to Work Wear...centralized financial control...and decentralized operational control.

“With the 3790 system, we're giving data—and the responsibility for handling it—to our sales regions. And corporate is getting a complete picture of the financial state of the company in real time...which means in time to act on it.”

Why do you say those are major benefits?

“Because of the nature of our business. We rent and launder work clothes and industrial and linen supply items at 33 remote locations across the country. That's problem number one—geographical dispersion. And every day we've got to account for four or five million pieces of laundry that are somewhere in the process of being picked up, cleaned or delivered to our customers. That's problem number two—a fantastic amount of detail work to keep track of daily.”

How did you handle all that before?

“Badly. Three years ago, I would have said that our major product was paperwork. Paper reflecting over a million transactions a month flowed from the plants to four regional data centers, where it was keypunched and entered in local computers. These in turn transmitted the data to the central computer at our Los Angeles headquarters.

“By the time everything was logged in and errors reconciled, the information was out of date. It was history. Moreover, it was indigestible. Different standards used in different regions resulted in data incompatibility.”

What changes have you made?

“When the 3790 system is completely installed—most of it is already in place—data from all 33 locations will be transmitted at the close of each business day to our Model 145 in Los Angeles. By the start of the next morning, management can know exactly where we stand, company-wide, on order volume, bank deposits, accounts receivable, inventory status, and other vital information. That's what makes centralized financial control possible.”

How is the data entered in field locations?

“Each plant has two or three 3275 Display Stations linked to its own 3791 controller—a programmed unit that cuts down the burden on our central computer. As each item is entered at the terminal, it's checked for validity, with corrections being made on the spot. It then goes to the controller, where the plant data files are updated. At night, the controller transmits the day's data to the 145, which updates the company-wide master files.

“The 145 then prints out documents like the day's invoices and drivers' pickup slips—between 40,000 and 50,000 of each daily, or some two million a month—for distribution by courier back to the plants. But starting in the summer, all this plant work will be offloaded through the 3790—a tremendous step forward.”

What do you mean by “offloaded”?

“There'll be a line printer at each plant. The 3790 will process and print data on this printer for onsite production of all the plant's daily documents. This means they'll produce their own invoices, pickup slips and load reports almost immediately. No more waiting for courier deliveries. That's what I mean by decentralized operational control.”

Is data also available interactively?

“Yes, both at plants and at headquarters. Information is always current and accessible for quick response to any inquiries, including trend analysis and other management information programs.

“Incidentally, if we should acquire new plants, they can be added to the 3790 network by simply installing hardware. All our programs are written, assembled, tested and stored on our Model 145, ready for use when our plants need them.

“We think that extending computer power to the field via the 3790 is the way to go for many companies. It certainly is for Work Wear.”

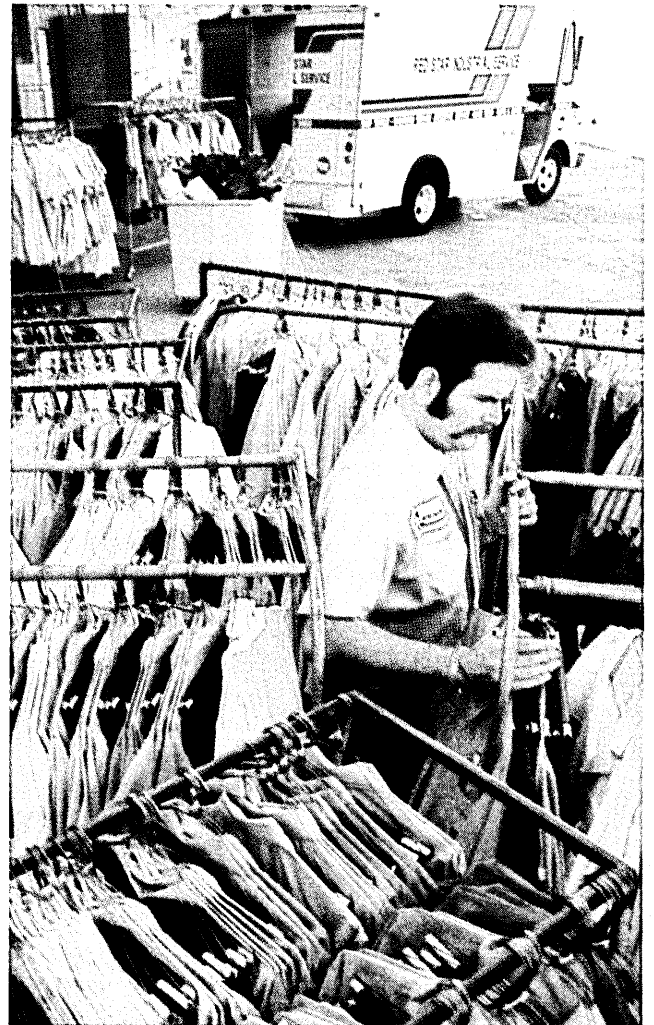

Rental uniforms being loaded at a Work Wear laundry for delivery to customers. The 3790 has meant greater control for Work Wear, from loading dock to corporate office.

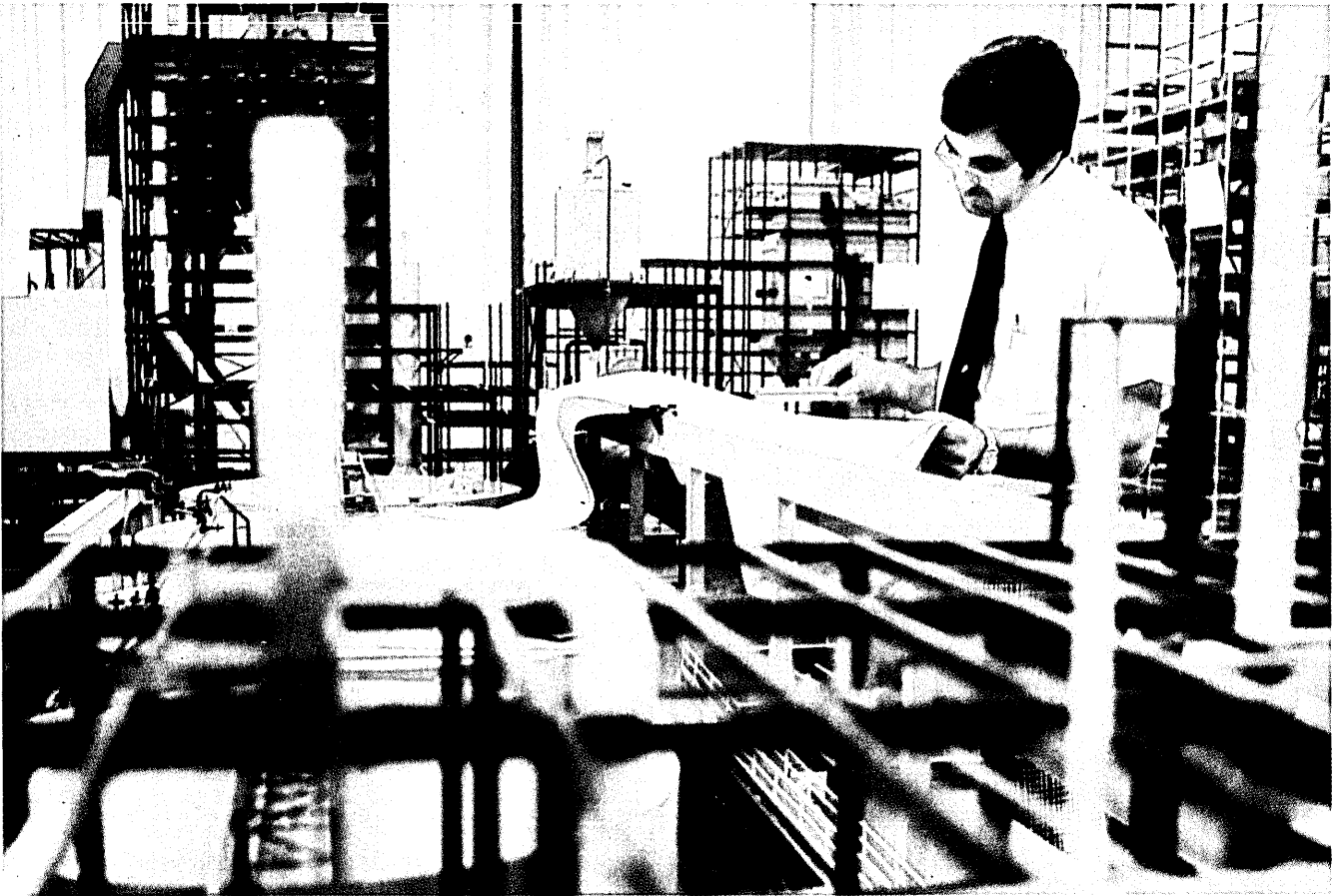

Based on specification reports developed under ATMS, models of new construction projects are created at Chas. T. Main, Inc.

Producing Customized Specifications with ATMS

Last year, the Boston-based engineering firm of Chas. T. Main, Inc., produced over 20,000 pages of design specifications for construction projects in the electric power, pulp and paper, printing and publishing, and general manufacturing industries.

"Whether the assignment involves the design of a new factory, plant additions, or an environmental system," says Howard Broad, manager of data processing, "our business demands that we organize and edit pertinent information efficiently and accurately."

To meet what amounts to constant deadlines, engineers at Chas. T. Main use a comprehensive series of "master specifications", or standardized designs, and an IBM Program Product, the Advanced Text Management System. ATMS, a powerful editing and command language, allows the firm to retrieve master spec data stored on a System/370 Model 145 and to modify it to fit each new project.

The ATMS concept is simple. Any text material, once entered into the computer system, never needs to be re-entered. Simple editing commands and typing are used to make additions, deletions or changes.

"We've put all our master specs into the ATMS system," says Howard Broad. "If an engineer needs to specify a particular kind of pump in a utility system, he goes through a master index and checks off all paragraphs that pertain to that topic."

The request is then forwarded to an operator, who executes the text retrieval by typing in the ATMS commands on an IBM terminal linked to the computer. Within minutes, hard copy can be generated on an IBM 1403 high-speed printer, or at the operator's terminal. ATMS may also

be used effectively with IBM 3277 Display Stations for text editing and proofing final output. Both methods eliminate time-consuming card punching and verification.

"The engineer can pencil in specific details, such as heights, weights and temperatures. These modifications can be entered at the terminal," says Howard Broad. "At the same time, irrelevant portions of the master spec can be deleted and additional paragraphs added. All new information is automatically stored on computer disks.

"Because large portions of the master specs don't need to be retyped or reproofread, ATMS has significantly improved our turnaround time. We've eliminated clerical overtime and substantially reduced our per-page production costs since we started using ATMS.

"Equally important, ATMS is helping us to assemble better master specs. With it, we are able to update continually such information as environmental standards, improved materials and new test procedures," he continues. "The more standardized and disciplined our specifications, the better we can serve our clients."

DP Dialogue appears regularly in these pages. As its name suggests, we hope DP Dialogue will be a two-way medium for DP professionals. We'd like to hear from you. Just write: Editor, DP Dialogue, IBM Data Processing Division, White Plains, N.Y. 10604.

IBM®

Data Processing Division

75-6

If you use terminals, here are four reasons you should know I.C.E.

Single source.

It used to be that getting the best data terminal meant scouring the entire industry to see what was available. No more. Now I.C.E. does it for you. One phone call gets you the latest and best terminals available today—either keyboard, print, or video display. We offer the most efficient terminals available in today's marketplace. Like Texas Instruments 735 portable terminals, DEC LA 36 printers, ADDS and Lear Siegler CRT's.

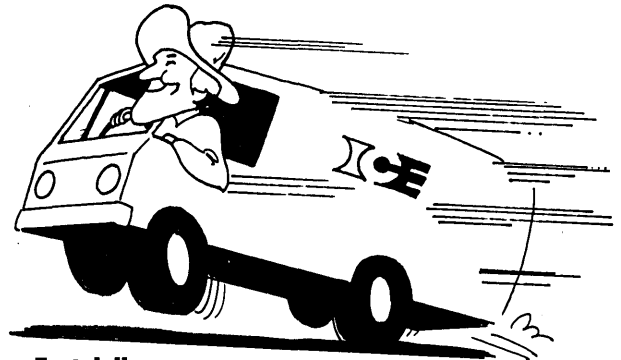
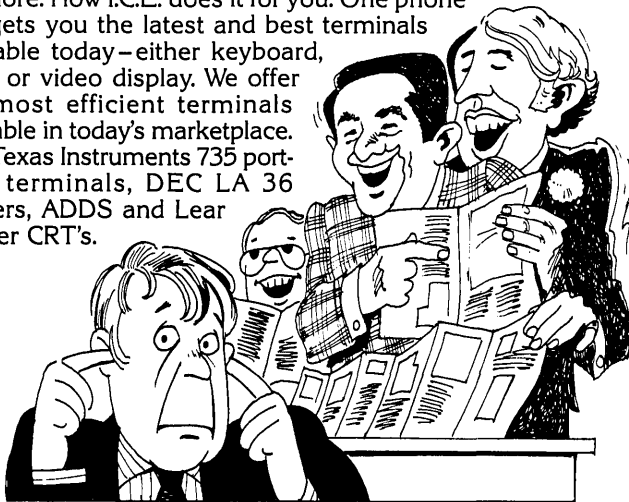

Fast delivery.

We've also eliminated the hassle of slow deliveries by stockpiling our own local hardware inventories. Instead of waiting months to receive your terminals, we deliver fast with instant installation. So when you need terminals, we're there to get you started. Right now.

Low cost.

We've cut the cost of data terminals by applying one of the oldest business principles to the market: volume buying. When you call I.C.E. you don't get the single unit list price, you get a lower price from a volume buyer. Simple logic, but very effective. And when it comes to leasing, we'll even arrange that if you like. We'll handle all the details. After all, we are a service business.

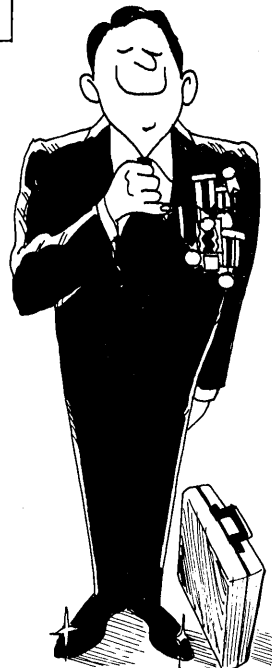
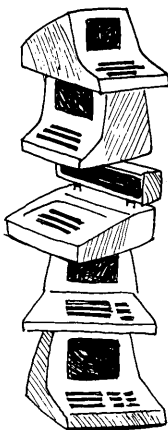

Servicing.

Once you're an I.C.E. account, you've gained a partner. We're not a "sell and run" outfit. We support our systems with servicing from our own spare parts depot. Our technicians are factory-trained, and our programmers and analysts will provide on-site consulting and training. And all our software comes with documentation and training. For more information on I.C.E. services, call or write our nearest field office.

ICE INTERNATIONAL
COMPUTER
EQUIPMENT, INC.

SALES OFFICES
WESTERN REGION: San Francisco
2030 Union Street
San Francisco, California
94123
(415) 563-7155

Los Angeles
11222 La Cienega Blvd., Suite 570
Los Angeles, California
90304
(213) 641-2001

MIDWESTERN REGION: Chicago
3166 Des Plaines Avenue
Des Plaines, Illinois 60018
(312) 694-3777
(312) 298-0777

Opening soon—New York and Houston

Delegate Responsibility!

"We make full use of the ENTREX System 580's source data processing and file interrogation capabilities to keep accurate, up-to-date information easily available throughout the company. Sure, it's a "data entry" system, and it's increased our normal data entry productivity by 35%, but we believe in using *all* its capabilities," says John R. Steiger.*

"That's why we have DATA/SCOPE Keystations in seven different departments, moving data input responsibility back to the source. Department personnel enter their own data, eliminating input operator interpretations and batch control errors.

"Each department has access to extensive information files, including an ISAM file which contains information about all parts utilized in our manufacturing process. Thus, when a user requires up-to-date information on a specific part, he simply keys the part number and receives all pertinent information on the DATA/SCOPE screen."

System 580. With features like ISAM files which provide instantaneous access to a million-character file. Add a 29-million-byte disk, Audit Trail, and ENTREX's full range of unique system features, and you've got **true source data entry and complete data management.**

* Manager of Management Information Systems, VariTyper Division, Addressograph Multigraph Corporation, East Hanover, N.J.

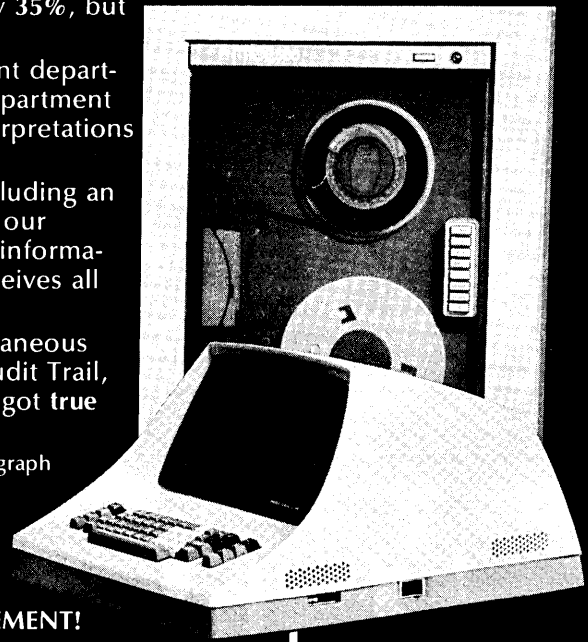

**WE CALL IT SYSTEM 580.
YOU'LL CALL IT GOOD MANAGEMENT!**



DATA ENTRY CENTER



ACCOUNTING

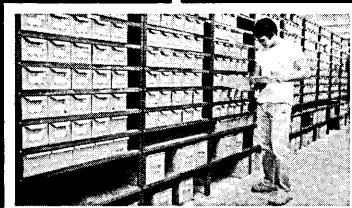

INVENTORY CONTROL



PURCHASING



MANUFACTURING

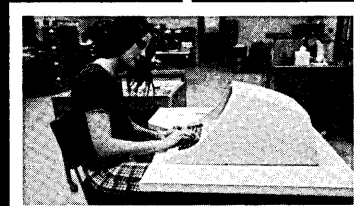

PRODUCTION CONTROL

ENTREX

168 Middlesex Turnpike
Burlington, MA 01803. 617-273-0480

Atlanta, GA, 404/634-6391 • Baltimore, MD, 301/997-3310 • Boston, MA, 617/273-0480 • Charlotte, NC, 704/568-3510 • Chicago, IL, 312/782-5427 • Cleveland, OH, 216/741-3636 • Clifton, NJ, 201/472-0382 • Columbus, OH, 614/451-1058 • Dallas, TX, 214/630-3343 • Denver, CO, 303/770-1030 • Detroit, MI, 313/355-0108 • Hartford, CT, 203/563-3866 • Houston, TX, 713/467-3715 • Indianapolis, IN, 317/352-1739 • Kansas City, MO, 816/531-1931 • Los Angeles, CA, 213/879-1960 • Louisville, KY, 812/283-1169 • Madison, WI, 608/221-1547 • Miami, FL, 305/949-4544 • New York, NY, 212/682-2130 • Oklahoma City, OK, 918/582-0572 • Philadelphia, PA, 215/265-2270 • San Francisco, CA, 415/692-5551 • Springfield, IL, 217/789-7709 • St. Louis, MO, 314/727-0480 • Toronto, Ontario, 416/495-1234 • Washington, DC, 301/997-3310

CIRCLE 31 ON READER CARD

INV NO	INV DATE	TYPE	PAID	CNTL	DISCOUNT	NET	CURRENT
115325	5/30/75	PRO		21439		105.00	105.00
115326	5/30/75	PRO		21440		45.00	45.00
115327	5/30/75	PRO		21441		3,990.81	3,990.81
115328	5/30/75	PRO		21442		2,491.71	2,491.71
115329	5/30/75	PRO		21443		1,632.46	1,632.46
115330	5/30/75	PRO		21444		530.37	530.37
115331	5/30/75	PRO		21445		7.60	7.60
115332	5/30/75	PRO		21446		120.00	120.00
115333	5/30/75	PRO		21447		102.04	102.04
115334	5/30/75	PRO		21448		1,502.98	1,502.98
115335	5/30/75	PRO		21449		126.11	126.11
115336	5/30/75	PRO		21450		286.95	286.95
115337	5/30/75	PRO		21451		1,648.98	1,648.98
115338	5/30/75	PRO		21452		341.94	341.94
115339	5/30/75	PRO		21453		1,943.01	1,943.01
115340	5/30/75	PRO		21454		142.90	142.90
115341	5/30/75	PRO		21455		8.99	8.99
115342	5/30/75	PRO		21456		858.57	858.57
				21457			
				DIVISION TOTAL		24,070.41	24,070.41
				CLIENT TOTAL		1,283.59	1,283.59

A/R LIST AS OF 05/31/75

Could you be put out of business before you could put out a fire?

At the very least, a computer fire means you'd probably have to hire temporary accounting help, just to keep the books and payroll current.

And it could be even worse if a computer is what makes your company go. No computer, no income.

Computer downtime is expensive.

Consider what a fire would cost in terms of lost business while repairs were being made. How much business do you do in a week? How many orders go through your operation in a week? And what if repairs took two weeks? Or even three?

It adds up to a lot of lost business (not to mention lost goodwill from customers). It probably adds up to a lot more than the cost of a fire protection system, too.

America's computers are under-protected.

With the future of your company largely dependent on your computers, we hope you have a good fire protection system already installed.

If you do, then you're an exception. Because we know that only a small percentage of existing computer facilities in this country have adequate fire protection systems. We are also aware of the tremendous losses that EDP facilities suffer each year due to fires.

How many kinds of computer fire protection systems are there?

There are only two that are practical, CO₂ and HALON 1301. Chemetron has them both.

Get a free fire protection survey.

We'll conduct a thorough survey

and analysis of your computer installations and put together a detailed recommendation on the fire protection system that's right for you. No cost or obligation, of course. Write today for our brochure, "HALON 1301, Folio 9-2," to Don Roberts, Chemetron Fire Systems, 111 E. Wacker Drive, Chicago, Illinois 60601. Or call (312) 565-5000.

We hope you'll do it now. Because our business is to help keep you in business.

CHEMETRON™

Fire Systems

Chemetron Corporation

Tracking Reliability and Availability

by C. H. Reynolds and J. E. Van Kinsbergen

Though reliability is fixed at the time the hardware is built, availability is a function of configuration design.

In 1970, it seemed very logical for Hughes Aircraft Co. to consolidate dp operations then running on three IBM 360/65 class machines—as a combination of batch, remote batch, and time-sharing of various sorts—onto a duplexed set of 370/165s. While it may have been logical, it turned out that it was not at all an easy process. It strained dp personnel and the users almost to the breaking point.

Out of that effort have come some conclusions about large system installations which now look simple and straightforward, and are probably, in fact, old hat to many. However, at the time we were going through our problems, we found no information to guide us from our vendor, and had to develop most of the information and conclusions that we present here on our own.

With the thought in mind that there may be others who may benefit from our experience, we have the temerity to present the obvious. Let's start with the conclusions, which are as follows:

1. *Reliability* is a function of the hardware which is used. (For purposes of this discussion, we will define the reliability of a box or a system as the mean time between failures.) Each box has a fundamental failure rate, which is immutable. For a given set of system software, the reliability of a system is fixed at the time it is built for all practical purposes. No amount of effort will improve it enough to make a significant difference in performance.

2. *Availability*, on the other hand, while limited by the reliability of the hardware, is much more a function of system design—that is, how the hardware is hooked together, the software

that makes the hardware work, and the procedures for using the system.

In any system in which the principal objective is availability, reservation systems for instance, this fact is taken into account. The cost of the necessary design and the redundancy of the

EQUIPMENT INVENTORY	
2—	3 M-byte 370/165
32—	3420-7 Tape Drives
8—	3420-5 Tape Drives
8—	3830-2 Disc Control Units
70—	333X Disc Spindles
12—	Block Multiplexor Channels
2—	Byte Multiplexor Channels
4—	Selector Channels
2—	COMTEN 3670 Transmission Control Units
20—	Remote Batch Medium to High-Speed Terminals
100—	ATS Terminals
50—	IMS Keyboard Terminals
45—	TSO Dial-up Ports
5—	1403 Local Printers
3—	3211 Local Printers
12—	ASP Consoles

Table 1. Operations including a combination of batch, remote batch, and time-sharing, previously run on three IBM 360/365s, were consolidated onto a duplexed set of 370/165s in the configuration shown here.

hardware, or the development of special software, is taken for granted and is cost justified by the nature of the application.

In our case we are talking about the routine evolution of an IBM installation from the batch days to the days of on-line operation. In this situation, one may feel secure in the vendor's "system-assurance" function. He may also have his potential fears masked by his desire to move ahead at the least possible additional cost. However, such an

attitude can lead to extreme difficulty. Normal IBM os/360 software was not designed for availability and easy restart.

3. *Changes in basic reliability* have to be large (factors of three or so) to have significant impact on system performance as seen by the users. The meaning, and therefore, the impact of a given rate of failure was not fully understood by us in the beginning.

Planning an upgrade

In 1970, Hughes operated three major computer centers in two different locations. Two of them had IBM 360/65s, one located in Los Angeles and the other in Fullerton, California, about 33 miles away. The third was a dual processor GE 635, also in Los Angeles.

The Los Angeles 360/65 was primarily dedicated to local batch, with a few terminals operating GIS and IMS. The GE 635 there was operated primarily for remote batch work with five high-speed remote job entry terminals, and approximately 30 time-sharing terminals.

The Fullerton 360/65 performed primarily local batch processing but supported approximately 40 ATS terminals.

A plan was developed to centralize operations on a pair of 370/165s, operating under ASP in Fullerton, to do TSO, ATS, IMS TP, and remote job entry. Proposals from three vendors were obtained, and IBM (surprise!) was selected. The current configuration is shown in Table 1. It is substantially the configuration proposed by IBM. The first system was installed in September of 1971, and the second system was



766/479
THE U.S. COMPUTER INDUSTRY
by G. W. Brock
Pub. price, \$15.00
Club price, \$12.50

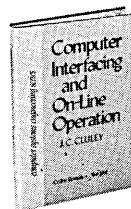

767/017
COMPUTER INTERFACING AND ON-LINE OPERATION
by J. C. Cluley
Pub. price, \$14.50
Club price, \$12.35

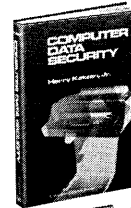

767/068
COMPUTER DATA SECURITY
by H. Katzan
Pub. price \$12.95
Club price, \$9.75

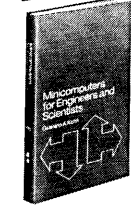

353/387
MINICOMPUTERS FOR ENGINEERS AND SCIENTISTS
by G. A. Korn
Pub. price, \$21.50
Club price, \$13.95

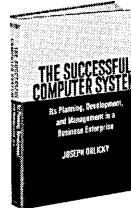

476/993
THE SUCCESSFUL COMPUTER SYSTEM
by J. Orlicky
Pub. price, \$11.55
Club price, \$8.95



394/555
OPERATING SYSTEMS
by S. E. Madnick and J. J. Donovan
Pub. price, \$18.50
Club price, \$12.50

Introductory offer to new members of the **COMPUTER PROFESSIONALS' BOOK CLUB**

any one
of these great
professional books
for only **\$1.00**
values up
to \$21.50

**Special \$1.00 bonus book comes to you
with your first club selection**



770/271
BUCHSBAUM'S COMPLETE HANDBOOK OF PRACTICAL ELECTRONIC REFERENCE DATA
by W. H. Buchsbaum
Pub. price, \$17.95
Club price, \$13.50



497/672
INFORMATION SYSTEMS THROUGH COBOL
by A. S. Philippakis and L. J. Kazmier
Pub. price, \$12.95
Club price, \$9.95



766/053
SYSTEMS SIMULATION
by A. M. Colella, M. J. O'Sullivan, D. J. Carlino
Pub. price, \$16.00
Club price, \$12.95



767/084
THE SUN NEVER SETS ON IBM
by N. Foy
Pub. price, \$7.95
Club price, \$6.75



770/212
FUNCTIONAL ANALYSIS OF INFORMATION NETWORKS
by H. B. Becker
Pub. price, \$14.95
Club price, \$10.95



546/215
COMPUTERS AND MANAGEMENT IN A CHANGING SOCIETY, 2/e
by D. H. Sanders
Pub. price, \$9.95
Club price, \$7.95



158/274
MANAGEMENT INFORMATION SYSTEMS: CONCEPTUAL FOUNDATIONS, STRUCTURE AND DEVELOPMENT
by G. B. Davis
Pub. price, \$15.50
Club price, \$11.95



767/130
WHY INFORMATION SYSTEMS FAIL
by H. C. Lucas, Jr.
Pub. Price, \$11.00
Club price, \$8.95

save time and money by joining McGraw-Hill's new **COMPUTER PROFESSIONALS' BOOK CLUB**



THIS new professional club is designed to meet your day-to-day on-the-job needs by providing practical books in your field on a regular basis at below publisher prices. If you're missing out on important technical literature—if today's high cost of reading curbs the growth of your library—here's the solution to your problem.

The *Computer Professionals' Book Club* was organized for you, to provide an economical reading program that cannot fail to be of value. Administered by the McGraw-Hill Book Company, all books are chosen by qualified editors and consultants. Their understanding of the standards and values of the literature in your field guarantees the appropriateness of the selections.

How the Club operates: Every month you receive free of charge *The Computer Professionals' Book Club Bulletin*. This announces and describes the Club's featured book of the month as well as alternate selections available at special members' prices. If you want to examine the Club's feature of the month, you do nothing. If you prefer one of the alternate selections—or if you want no book at all—you notify the Club by returning the card enclosed with each *Bulletin*.

As a Club Member, you agree only to the purchase of four books (including your first selection) over a two-year period. Considering the many books published annually, there will surely be at least four you would want to own anyway. By joining the club, you save both money and the trouble of searching for the best books.

MAIL THIS COUPON TODAY

COMPUTER PROFESSIONALS/Book Club
P.O. Box 582 Princeton Road, Hightstown, New Jersey 08520

Please enroll me as a member of the Computer Professionals' Book Club and send me the two books indicated below. I am to receive the bonus book for just \$1, and my first selection at the special Club price. Actual postage, plus 25¢ handling charge will be added (sales tax, also, if applicable). These books are to be shipped on approval, and I may return them both without cost or further obligation. If I decide to keep the books, I agree to purchase as few as four additional books (including this first selection) during the next two years at special Club prices (guaranteed 15% discount often more).

Write Code # of \$1.00
bonus book
selection here

Write Code # of
first
selection here

NAME _____

ADDRESS _____

CITY _____

STATE _____ ZIP _____

P39118

TRACKING

installed in June of 1972. The 360/65s were released, but the 635 remained in place.

We struggled all during late 1971 and 1972 with the task of moving the bulk of our people and workload from Los Angeles to Fullerton, putting all the systems under ASP, integrating three organizations, and working with an unhappy, if not disgusted, user community. It soon became clear that we couldn't keep the systems running very well. In discussions with IBM, we could get no satisfactory answers as to why or what we could do about it.

Tracking our troubles

It was at this point that we started to gather data in great detail about the source of our troubles. The information gathered included:

1. date and time of failures
2. amount of lost time
3. system and responsible component
4. a type and sub-type code that indicates the cause of the failure

The data presented here was collected over a 2½ year period.

An interesting adjunct to this effort has been the evolution of the data format into other areas such as abends, ASP returns, and on-time delivery performance. The results from these efforts are not included here.

What's involved

The data collection problem is compounded by the fact that many elements of the organization must be involved in order to determine the exact cause of failure. At the minimum, people from three elements of the organization, systems programming, operations, and IBM field engineering, must be gathered together to analyze failure information. Since this is a time consuming process, failure data collection is of necessity somewhat delayed. The process is as follows:

1. Console operator logs all perti-

nent information concerning the failure.

2. Systems Programming and IBM analyze all failure data to determine cause.
 3. A weekly meeting is held with the three elements of the organization in order to finally pinpoint the type, cause, and the systems component which failed.
 4. A weekly log is transmitted into the reliability data base via TSO.
- On a regular basis, listings of the data base are made and transmitted back to

Systems Programming in order to update any items that might have been delayed or changed.

As a result of the above, the data base is maintained on a reasonably timely basis, with accurate information concerning type and cause of failure.

What we found

Gathering this data initially allowed us to draw some pretty clear conclusions. First, Table 2 shows the distribution of failures caused by hardware, software, operator error, CE interven-

FAILURE BY CAUSE

FAILURE CAUSE	TOTAL NUMBER	PERCENTAGE OF TOTAL
Hardware	966	44%
Software	478	22%
Applications	36	2%
Operations	139	6%
Other	343	16%
Unknown	40	2%
Reconfiguration	172	8%
TOTAL	2,174	100%

Table 2. Hardware seems to be the major cause of failure. Reliability is determined by the hardware no matter what is done with the rest of the operation.

IPL RATE JULY-DECEMBER 1974 (DUPLXED IBM 370/165s)

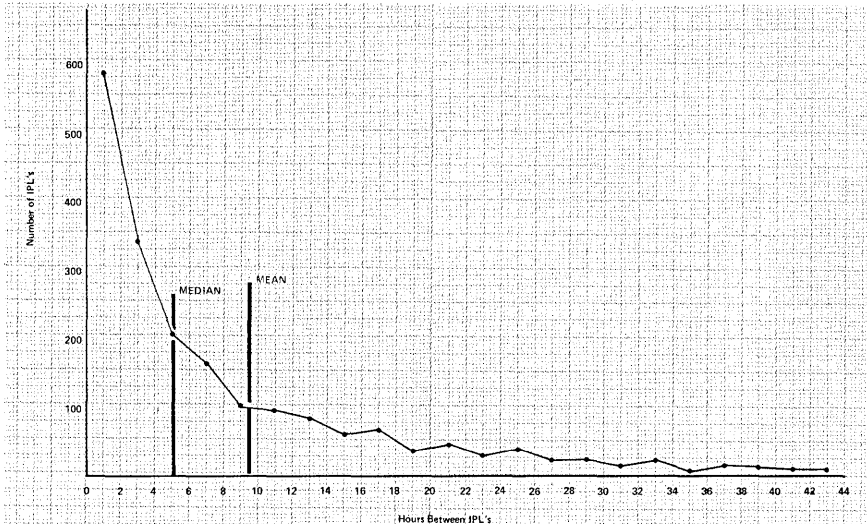

Fig. 1. The frequency distribution of failures during one period revealed the median time between failures to be half the mean (average) time. Thus a mean time between failures of 10 hours indicates that half the time there is a failure every five hours.

MTBI (MEAN TIME BETWEEN IPLs) & AVAILABILITY CALCULATIONS

	2nd ½ 1972	1st ½ 1973	2nd ½ 1973	1st ½ 1974	2nd ½ 1974	TOTAL (2½ Yrs.)
WALL CLOCK TIME (hrs.)	4,392	4,368	4,392	4,368	4,392	21,912
SCHEDULED DOWN (hrs.)	248	359	379	369	519	1,874
UNSCHEDULED DOWN (hrs.)	421	356	379	247	325	1,628
AVAILABLE TIME (hrs.)	3,723	3,653	3,634	3,752	3,524	18,286
	(AVERAGES)					
PERCENT AVAILABLE	89.8%	91.1%	90.6%	93.8%	91.6%	91.8%
PERCENT UNAVAILABLE	10.2%	8.9%	9.4%	6.2%	8.4%	8.2%
UNSCHEDULED IPLs	484	458	405	326	390	2,063
MTBI (hrs.)	7.69	7.98	8.97	11.51	9.04	8.86
MEAN DOWN TIME (hrs.)	.87	.78	.94	.76	.83	.79

Table 3. Careful data was kept over a 2½ year period for comparing MTBI Mean Time Between IPLs (Initial Program Load) with percent of availability. Failure of one or both systems

was on the average less than nine hours, while availability was almost 92%.

Who beat — IBM DEC Univac Lear-Siegler?

VISTAR — by Infoton that's who!

In a recent survey of alpha-numeric display terminal users conducted by Datapro Research Corporation, Infoton's Vistar Series achieved exceptionally high ratings and was placed on the 1975 Datapro Display Unit Honor Roll.

To earn a place on the Honor Roll a terminal had to receive an average overall performance rating of 3.5 or better on a scale of 4. The Vistar Series earned a rating of 3.8 in Overall Performance!

Other categories evaluated where Vistar received good to excellent scores were Reliability, Maintenance/Service, Software/Technical Support and Ease of Operation.

The Vistar Series topped virtually every other manufacturer of teletype compatible CRT display terminals in Datapro's ratings!

Write or call today for complete information on these high quality, low-cost terminals. We'd welcome the opportunity to tell you why we topped IBM and the rest!

Contact:
Mr. Edward McCormack
National Sales Manager

Infoton
Second Avenue
Burlington MA 01803
(617) 272-6660

Company owned,
nationwide service available
by contract or on demand.

Infoton is a division of
Optical Scanning Corporation

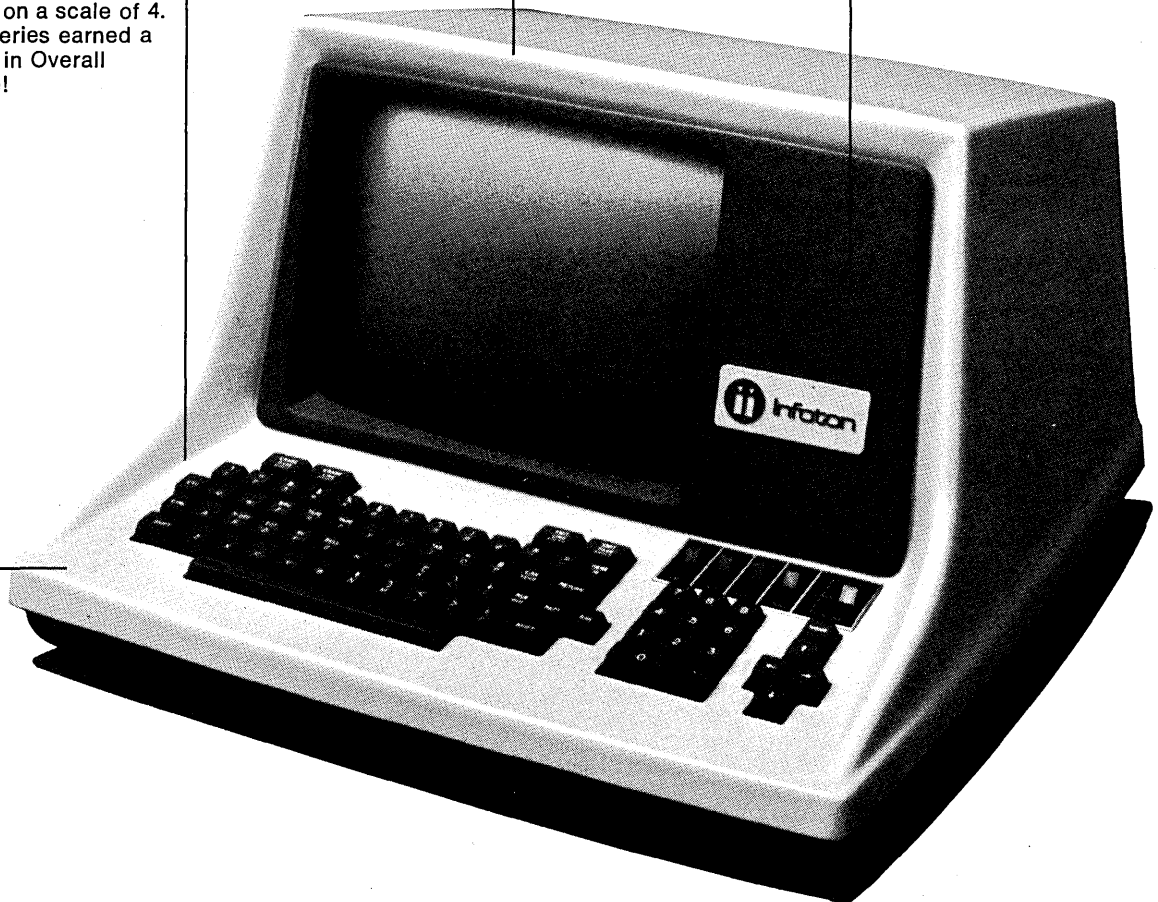

Try our co layaway

Hurry.

To the disk drive sale of the year.

Featuring year-end clearance prices.

On the fastest selling, low-cost, fixed-media moving head disk drives in the industry.

On brand-new, never-before-advertised units

from Pertec.

Orders for two models are greater than current production capacity. So, hurry:

Pertec's got a couple of hot ones.

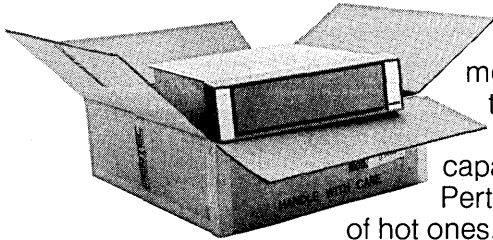

The D1400: Lay it away now.

The new D1400 is our 6 megabyte capacity model.

It offers a combination of outstanding features at exceptionally low cost, including: A 2316-type non-removable platter; bit density of 2200 BPI; track density of 200 TPI; available at either 1500 rpm or 2400 rpm.

Its Pertec-standard interface is compatible with almost every disk drive. And, its chassis (standard 19 inch panel width, by 22.4 inch rack depth, by 5.25 inch height) makes it fit where you want it to fit.

OEM's can use its average seek time of 70 ms and track-to-track seek time of 12 ms to improve the performance of their system design.

So, buy the Pertec D1400 *now*.

And start laying it into your new systems.

While you smile all the way to the bank.

The new D1400. The buy-it-now, get-it-soon, lay-back-and-make-money-for-you disk drive. From Pertec.

It's a sweetheart.

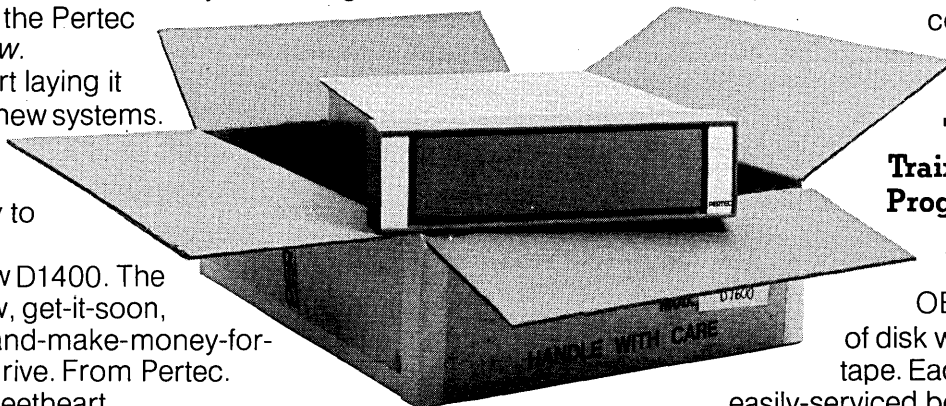

The D1600: Lay it away in December.

The new D1600 is our 12 megabyte capacity model.

(Double the capacity of the D1400: Only 15% more cost than the D1400.)

It offers OEM's a configuration of features that 12 megabyte customers require, including: A 3336-type non-removable platter; bit density of 4400 BPI; track density of 200 TPI; available at either 1500 rpm or 2400 rpm.

(All the standard features in our 6 megabyte model are standard in the D1600.)

OEM's can specify a Pertec-standard interface or configurations compatible with other disk drives of other manufacturers.

Chassis size? Same as the D1400.

Average seek times? Same as the D1400.

Media protection assuring highly reliable operation and data integrity, improved air filtration and sectoring configurations up to 64 sectors, make the D1600 an OEM favorite.

But there's a catch: You can buy the Pertec high-capacity, low-cost D1600 *now*.

But you can't lay it into your new systems until December.

Orders for the D1600 are being accepted now.

So buy it *now*. Lay it away *now*. And be among the first OEM's to be ahead of your competition in December.

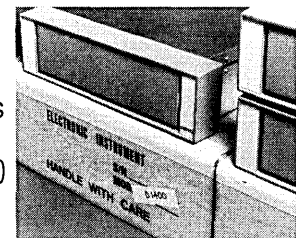

Buy at least one of each.

The Pertec Training and Spares Programs: Too Much?

The D1400 and D1600 provide OEM's the benefits of disk with the low cost of tape. Each drive has four easily-serviced boards which lift or

nvenient plan.

hinge for immediate access to circuitry. (No other disk drives are so designed.)

Why then a Pertec Training Program? And a Pertec Spares Program?

Our marketing people say, "To drive our competition crazy!"

Our product people say, "To make the product unbeatable!"

Either way, OEM's use both programs to enhance and complete the products and service behind Pertec's disk drives.

Is too much service too much? Ask Pertec customers, and decide for yourself.

Finally. The Layaway of Layaways: The D1200.

You're looking at Pertec's prototype model D1200, with a 3 megabyte capacity. For the OEM looking for *lower-capacity, lower-cost* drives. (After all, why buy a 6 or 12 megabyte capacity when you only need a 3?)

"Will it look like the D1400 and D1600 models?" you ask.

"Will it perform with Pertec reliability?" you probe.

When the D1200 is in volume production, it will *look* like the D1400 and D1600.

And, with the first OEM delivery, it will perform with Pertec reliability.

So, look into the D1200 *now*.

CIRCLE 63 ON READER CARD

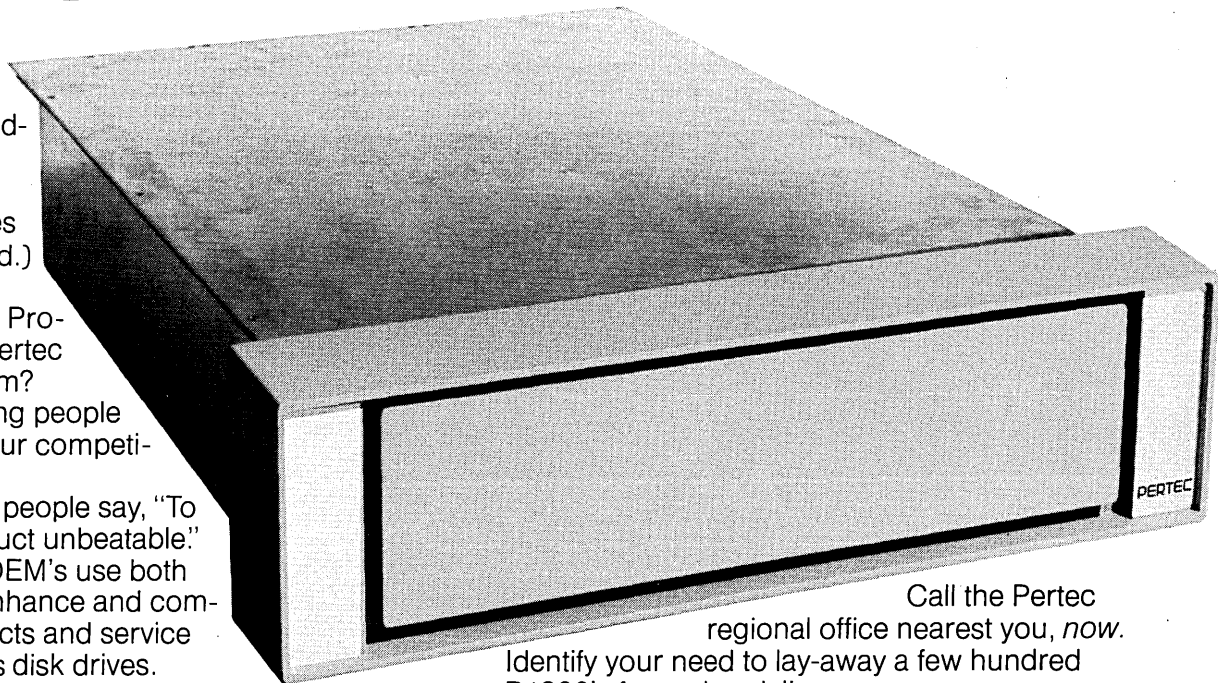

Call the Pertec regional office nearest you, *now*. Identify your need to lay-away a few hundred D1200's for spring delivery.

Then lie back and ask yourself, "Will Pertec really deliver a 3 megabyte disk drive?..."

"Should I wait 'til all my competitors have them?"... "Should I order a D1400 or D1600 now?"... "Or should I order some of each?"

The new Pertec disk drives. Delivering 6, 12 (and shortly, 3) megabyte capacity at OEM low-cost.

Will Pertec deliver?

Not unless you order, *now*.

So, hurry. And lay-away the finest performing fixed-disk drives in the industry.

PERTEC

Call the Pertec regional office nearest you:
Boston (617) 890-6230;
Chicago (312) 696-2460;
Los Angeles (213) 996-1333;
London (Reading) 582-115.
Or write: Pertec,
Peripheral Equipment Division,
9600 Irondale Avenue,
Chatsworth, California 91311.

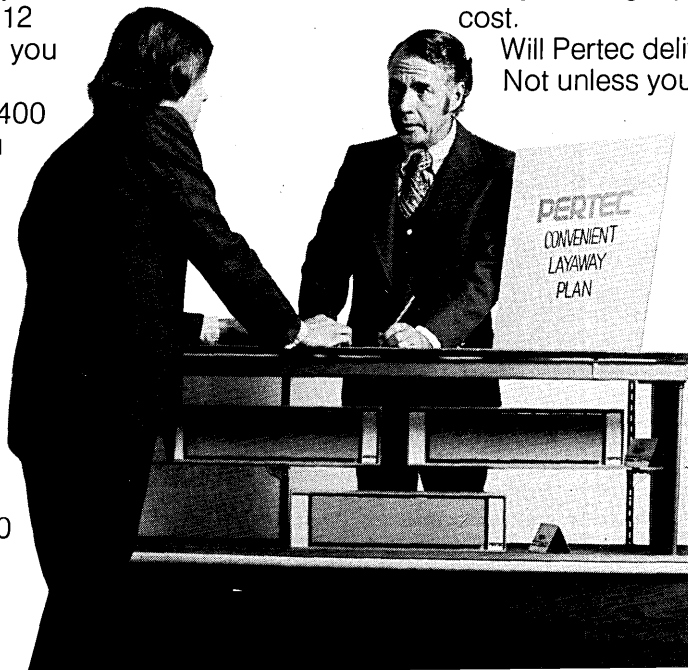

tion, and others. This indicated to us that the major cause of the failures was hardware, although extensive efforts were undertaken by us to reduce those parts of the problems which were under our control. Thus, the first conclusion of this article that fundamental reliability is a function of the hardware.

Reaching this conclusion was a lengthy (1-2 years) process. We struggled manfully with IBM, including their engineers, to make things substantially better.

Another fact which became apparent quickly was that whenever the mean time between failures fell below 10 hours, we could not get our work out. The reasons for this were soon obvious. Listing what has to be done in the event of a system crash requiring an IPL (Initial Program Load) gives some idea of the real losses of machine time and manpower that result from an IPL:

1. Diagnose the cause of the failure and determine how and when to restart (with a reduced configuration? only after a repair? eliminating specific jobs that were active when the failure occurred? etc.).
2. Dismount all tapes and disc packs for jobs active when the failure occurred.
3. Analyze each of the above jobs to determine how they must be restarted (restart at current step? change job control cards? rebuild a data base? etc.).
4. Perform the IPL itself and restart special software, such as ASP, TSO, IMS, ATS. This takes about 30 minutes.
5. Rerun jobs to the point they reached at the time of the failure.

It is apparent that the total impact depends on the size of the computing system and the jobs that happen to be running at the time of the failure. On a 370/165, restarting the systems can be done in a half hour or less. Getting all the way back to the same job point at which the failure occurred usually takes over two hours and may get to five hours.

For this reason, in mid 1972, it became clear to us that the time between IPLs was of more significance than the percent of availability, which we will discuss later.

It was during this time that a continuing dialogue with IBM was started to emphasize this point, since the availability was over 90%. That sounds like a high number, when in fact, it is not.

Analyzing the data

Table 3 shows a comparison of the MTBI (mean time between IPLs) and

percent of availability for five half-year intervals, plus the 2½ years of the total system. Failure of one or both of the systems can be seen, in the average case, to be less than nine hours, yet availability was almost 92%.

During the course of analysis, and with help from IBM, we examined the frequency distribution of failures. (See data presented in Fig. 1.) The significant thing here is the relationship between the mean time between failures and the median time between failures. In general, the median time between failures is half the mean time. What this means is that if you have a mean time between failures of 10 hours, half of the time you will fail every five hours. In short, modest improvements in the mean time between failure of a system will have a negligible impact on the system as seen by the users. Good periods will be interspersed with bad periods. As near as we can tell, this is a law of physics, and has nothing to do with software or system design, other than the basic reliability of the components in the system.

As far as availability goes, our system has stabilized to some extent, partially by workload removal and partially by reconfiguring. However, we have become more concerned about availability. Clearly, 90% availability means that in a 10 hour workday the system is out of operation one hour. If you multiply one hour by 100 to 200 people at terminals, it becomes a significant cost.

And so . . .

Our conclusion has been that reliability is fixed and we must design our system to make it as available as possible with the reliability we have. We believe that the best reliability we can obtain is something on the order of 25 hours between failures of each system, or approximately 12 hours MTBI for the combined systems.

Since the reliability is built into the hardware, our only recourse is to work on the availability and that is what we have been doing. We have made some parts redundant; we have no single-box failure points to prevent the system from operating. We have as much multi-pathing as possible with the IBM design, and as many duplicate boxes as we can afford at the moment.

We work hard on our IPL procedures, and our system restarts, and we have prescribed rules for how much time one should take diagnosing a problem before the processor restarting is begun. Fundamentally, however, the availability is a function of the software, and the inability to store the machine at failure time and restart without extensive manual intervention.

It is clear to us, in retrospect, that the 370 generation of hardware and

EMM COMPUTER PRODUCTS DIVISION SALES OFFICES

BOSTON

EMM Corporation—(617) 861-9650

CHICAGO

EMM Corporation—(312) 297-3110

CLEVELAND

EMM Corporation—(216) 884-1980

DALLAS

EMM Corporation—(214) 243-2374

DETROIT

EMM Corporation—(313) 352-1040

HACKENSACK

EMM Corporation—(201) 845-0450

HOUSTON

EMM Corporation—(713) 626-3592

INDIANAPOLIS

EMM Corporation—(317) 545-3154

LOS ANGELES

EMM Corporation—(213) 477-3911

MINNEAPOLIS

EMM Corporation—(612) 941-2404

NEW YORK

EMM Corporation—(212) 736-2471

ORANGE, CA

EMM Corporation—(714) 997-4132

PHILADELPHIA

EMM Corporation—(609) 428-9391

SAN FRANCISCO

EMM Corporation—(415) 692-4250

SEATTLE

EMM Corporation—(206) 284-5413

WASHINGTON, DC

EMM Corporation—(703) 941-2100

TORONTO, ONTARIO

EMM Corporation—(416) 447-0301

BRUSSELS, BELGIUM

EMM S.A.—(0212) 3080

ESCHBORN, GERMANY

EMM GMBH—(06196) 4817

LONDON, ENGLAND

ELECTRONIC MEMORIES, LTD.—

(01-751) 1213

EMM

Your best memory investment.

Before you make a computer investment you carefully consider benefits... price, performance, reliability and reputation of the company.

When you expand your 370/145 memory capacity, EMM and the Multimemory/145 processor storage system are your best investments. Because you'll get cost and performance benefits of vertical integration—memory components, subsystems and systems all made by EMM. Because we make, sell, service and lease our systems. And because we continually develop new memory products.

Look at the product. Carefully. It's designed around our static NMOS semiconductor device. Total IBM compatibility with all 370/145 models as you take your computer capacity to 2048K bytes. Plus the ability to defer maintenance by reconfiguring your EMM and IBM memory segments.

Consider our low price. Lower operating expenses. High performance and reliability. Easy installation. Solid support. And all the features you need.

More users and computer manufacturers use EMM memory products than those of any other independent company. You couldn't make a better investment.

Let your EMM salesman help you plan your memory program.

Call your regional EMM sales office.



COMPUTER PRODUCTS DIVISION

Electronic Memories & Magnetics Corporation

12624 Daphne Avenue, Hawthorne, CA 90250

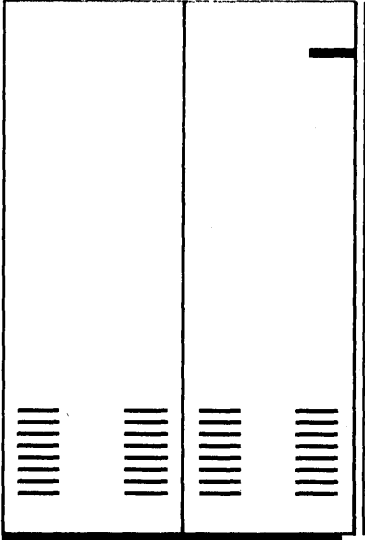
370/145  **memory**

This **Tbar** illustrated guide shows you how to keep your system UP... and your cost DOWN

T-BAR keeps your system UP by SWITCHING to BACK UP and MONITOR... T-BAR keeps your cost DOWN by eliminating redundant equipment through RECONFIGURATION. You should know about it...



8 Basic Switches • FALL BACK • MONITOR/BRIDGE • MATRIX • PATCH or NORMAL
4 Basic Controls • MANUAL LOCAL • MANUAL REMOTE • ASCII UNATTENDED REMOTE • COMPUTER

Write or phone for yours now!

Tbar INCORPORATED
 DATA SYSTEMS DIVISION

141 Danbury Road, Wilton, CT 06897
 Telephone: 203/762-8351
 TWX: 710/479-3216

CIRCLE 106 ON READER CARD

TRACKING

software is not substantially better than the second generation. The equivalent failure data on our 65s was essentially the same as that which we have collected on the 165s. Without specific detailed analysis of the system design, on-line operation at a service level commensurate with today's requirements and expectations is not possible on third generation equipment. One cannot evolve from the batch world to the on-line world.

In all additions and alterations to our installation, we expect to extrapolate from our experiences and data to ensure that the availability and reliability requirements of our applications will be met. It is significant that the necessary data and tools for such design procedures are not readily available from vendors. *



From 1962 to 1966 Mr. Reynolds was manager of systems programming for the Systems Development Div. of IBM. His dp experience began as least as far back as 1952, when he was manager of the Analog Computer Laboratory at Goodyear Aircraft.

President of Computer Usage Development Corp. between 1966 and 1968, and of Kappa Systems from 1968 to 1970, he was appointed corporate staff director of computing and data processing for Hughes in 1971.



Mr. van Kinsbergen is the manager of the corporate computing center at Hughes Aircraft Co. Prior to joining Hughes he was a vice president of Programming Sciences Corp, and prior to that he worked at IBM (on OS/360), ITT Data Systems, and Philco's Computer Division.

IBM and the structure of the industry

A Vicious Circle

We have a vicious circle in our industry. An important reason for IBM's dominant position in the computer industry is the influence of IBM on computer personnel which in turn helps to sustain IBM's dominant position in the industry.

The clearest example of this interaction is where it all begins: most computer people receive their first training with IBM equipment and techniques. Obviously IBM schools train for IBM; in order to attract students, private schools feature IBM; and in order to describe the real world, most public school texts feature examples of IBM. Clearly, most feel that IBM training leads to jobs.

Computer people will sometimes change jobs in order to stay up to date on computer techniques—which for some means the latest IBM techniques. When a user replaces IBM with Brand X, some people will feel acutely insecure until they can change jobs and again work with IBM equipment. It matters not that the Brand X installation may be ahead of the IBM installation in computer methodology; the IBM experience rates higher on a resume.

In most installations, vendor representatives have some influence on hiring. These representatives naturally want to enhance the value of their own special hardware-software offerings and so emphasize the importance of specific experience with these features in the recruitment of personnel. Also, a vendor rep for Brand X obviously does not want to see his big customer hire an effusive fan of Brand Y into a key position. The tendency of vendor influence is for the user to define dp jobs in technical terms and to fill them with people from the vendor family. In practice, representatives of Brands X, Y, and Z cannot avoid people with IBM training and experience, but there are many IBM installations where non-IBM exposure is zero.

The specificity of make and environment extends to top management jobs. Advertisements for VP's of Information Systems appear in the Wall Street Journal and call for experience with, e.g., 360 under os. This level job should require experience with a particular industry and with a general range of budgetary authority but not with specific hardware and software. With advertisements like these, it is no wonder that many dp people have divided loyalties between their employer and the computer industry. The person specified in this advertisement will effectively extend his experience with IBM, not act as a company VP for his employer.

I know two senior dp professionals who claim that their careers with users were hurt after they replaced, or attempted to replace, IBM equipment. The potential power of IBM as a source of references, good and bad, is frightening to most people with a family and a mortgage. I suggest that, as part of any antitrust judgment or consent decree, IBM should be constrained from giving personal references, except regarding their own ex-employees. Perhaps it would be possible to simplify legal procedures so that any and all rejected candidates could sue and collect from IBM if the company gave a reference or recommendation on a successful candidate who had never worked for the corporation.

I also suggest that industry associations begin an educational campaign to divorce senior dp management jobs from specific hardware and software. In the short term, letters of protest and explanation should be sent to the offending advertisers in the Wall Street Journal, New York Times, etc.

The owners of the major dp search firms should be directly contacted with the message that they will enhance their own candidates by giving full value to experience on any type of equipment—and extra value to experience with a variety of equipment. In the long term, the training programs for general business executives should stress the obvious idea that their in-house dp personnel ought not all have allegiance to the same vendor.

As things now stand, IBM is a state of mind as well as a company that sells excellent equipment and services. Whatever happens in the courts, the special power of IBM will persist until dp professionals who work for users are able to view the company merely as one of several potential vendors.

—Louis B. Marienthal
Mr. Marienthal, an independent consultant in Los Angeles, is also a contributing editor to Datamation.

Power to the Users' Ombudsman!

Several comments made in this department in the June issue deserve underscoring, and perhaps a little more exploration. Robert J. Michael suggested that users take a "hard line" with IBM in three particular areas: (1) competitive bids for all hardware; (2) accepting only "finished" operating systems; and (3) beginning to pay hardware rental only after acceptance.

Michael's thesis would be strengthened, I think, if a fourth item were added to his list: users should also take a hard line with IBM over their freedom to use add-on, plug-in and secondhand equipment. And taking a leaf from Ryal Poppa's comments, I'd also like to see a greater acceptance of the idea (which seems more prevalent in Europe than the U.S.) that a good computer and a good application can have a working life of 15 years or so, and after that time, both of them should be allowed to phase out gracefully, together.

More important, though, is the matter of accountability. Even though I think IBM's corporate behavior is on the whole pretty ethical, I would like to know that *somebody* has access to every meeting, every file cabinet throughout the company, and that the selected somebody is accountable not to Frank Cary but to me through the Justice Dept. The point here is that the ombudsman, Bob Bigelow's suggestion, should be a window into the hidden corners of the organization responding to complaints from outside with careful exploration and public response.

"Ombudsman" is a word that comes to us from the Swedes, and the concept has been in use there for decades. They brought in a new twist on April Fool's day this year, and it's giving IBM-Sweden a certain amount of discomfort. Employee representatives in every Swedish company are now entitled to have full access to all financial information about the company—and the company has to pay for training or consultants if employees don't understand it.

IBM's privacy is the real issue here, and I don't think that a company that big, in an industry this important, has as much claim to the luxury of privacy as the various individuals who are affected by intrusions (predominantly IBM) computers. I think IBM will fight fiercely to maintain the traditional barriers, but a demand for more public accountability, probably through the medium of an ombudsman, is one of the most reasonable and most effective remedies available to us.

It's ironic that what we're looking for are systems to "measure" and "control" this company whose systems measure and control so much of the rest of the industry. Yet the crux of the matter is not systems or measurement but human nature, raised to the power of 250,000 or so.

—Nancy Foy
Nancy Foy, Datamation's European editor, is the author of "The Sun Never Sets on IBM."

Tab makes -

**one desk for
CRT displays,**

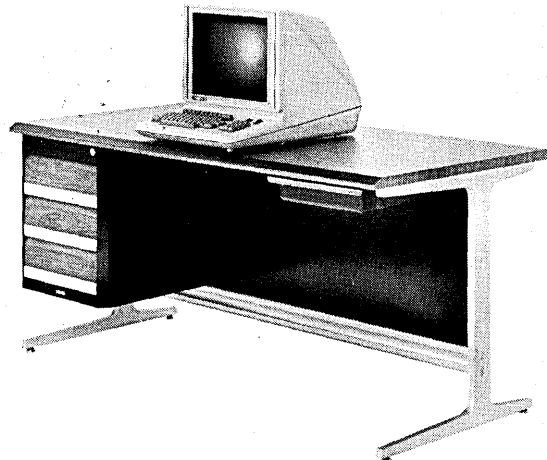

**one for
typewriters,**

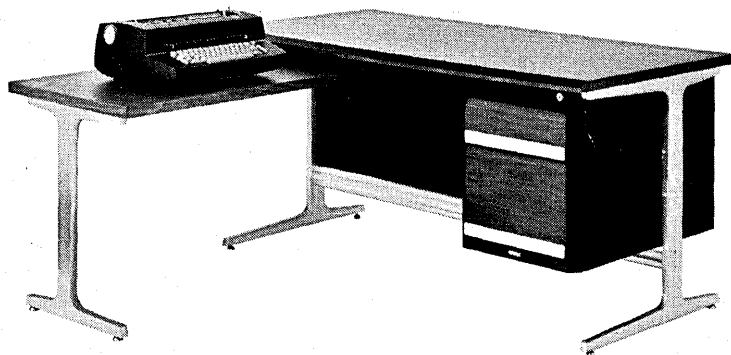

**one for
programmers,**

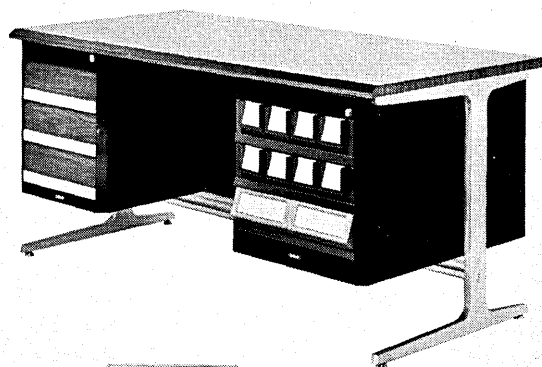

**one for
microfilm readers,**



and one for just plain work.



This one.

The function of Tab Data Display Desks can be adapted to whatever work you need to get done. Component options let you make the desk a programmer's work station; another change makes it ideal as a CRT desk; still other pedestals and desk returns can transform it into a secretarial desk; or, used without components, the desk is an ideal conference or work table. You select from 2 and 3 drawer pedestals, 6 and 12 drawer card files, desk return, modesty panels, 27"

and 30" heights and 31 $\frac{1}{2}$ ", 45" and 62" lengths to create the exact desk you need to accommodate virtually any function. Tab display desks come in black and simulated walnut or contrasting shades of grey, with pedestals in any color you need to suit your office decor.

For complete information contact your local Tab representative, or write Tab Products Company, 2690 Hanover Street, Palo Alto, California 94304.

Tab Data Display Desk
"Make of it what you will"

TAB
PRODUCTS CO

CIRCLE 49 ON READER CARD

For a low \$2495, Digital's VT55 Graphics Terminal reaches new heights.

Digital announces the VT55 Graphics Terminal. For use with anyone's computer. To handle a variety of applications more productively through the addition of graphics capability. With optional hard copy output. At a unit price as low as \$2495.

Use the VT55 for plotting histograms, waveform and peak analyses, data acquisition, monitoring, trending, simulation, laboratory charts and forms, or wherever your applications can be improved through graphics.

Automatic, upward line scrolling enables continuous data entry. Graphic cursors facilitate data editing and graph generation, with x-y plotting (2 values of y for each x) of two 512-point graphs.

Hard copy for either text or graphics display can be generated by an electrolytic copier that can be

integrated in the terminal.

A full keyboard offers the complete ASCII character set displayable in as many as 24, 80-character lines.

Terminal-to-computer communications speeds are variable up to a fast 960 characters per second.

The \$2495 graphics terminal from Digital. A new high for video display capability at a new low for graphics cost.

Write for our new brochure. LDP Graphics Group MR2-4/E14, Digital Equipment Corporation, 200 Forest Street, Marlboro, MA 01752. (617) 481-9511, Ext. 6933. European headquarters: 81 route de l'Aire, 1211 Geneva 26. Tel: 42 79 50. Digital Equipment of Canada, Ltd.

digital

LDP Graphics Group MR2-4/E14
Digital Equipment Corporation
200 Forest Street
Marlboro, MA 01752

- Please send a salesperson as soon as possible.
- Please send me literature.

Name _____

Title _____

Company _____

Address _____

City _____

State _____ Zip _____

Telephone _____



The Amdahl 470V/6

by Edward K. Yasaki, Senior Associate Editor

A functionally compatible competitor for the IBM 370, the machine has speed, power, and funny looking little fins for cooling IC's.

Amdahl Corp. last month finally held its long-awaited introduction of the 470V/6 computer. The machine, billed as the first fourth-generation computer, is software compatible with the IBM System/370—which means it runs IBM's os/vs operating system and that existing programs need no conversion.

Amdahl produces only the central processor and its console. The firm is not competing with IBM in the construction of peripherals, but this is not thought to be a problem. For instance, when the Univ. of Michigan acquired its machine recently, the configuration installed included a gaggle of peripheral equipment from the likes of IBM, Storage Technology, Intel, and Memorex; yet the site reported having no problems at all on the air.

The virtual storage machine uses the 370 architecture to achieve functional compatibility, implementing it with a more advanced semiconductor technology. The standard system includes the mainframe, one megabyte of main memory, 16K bytes of high-speed buffer memory, 16 I/O channels, an operator's console, and power distribution unit. That's priced at about \$3,650,000.

The short list of optional equipment includes one-megabyte increments of memory, up to eight megabytes, and a channel-to-channel adaptor for computer-to-computer communications. Moreover the 16 integrated channels can be used as byte multiplexors, block multiplexors, and/or selector channels, in any combination, and are switch-selectable at the site by the CE.

In the field, of course, diagnostic routines can be run from the operator's console, which uses a Data General Nova 1200 minicomputer to emulate the IBM 3066 console. But when standard procedures fail to uncover a problem cause, that mini can communicate with another in Amdahl's headquarters in Sunnyvale, Calif., where a diagnostic team can work with the remotely located, troubled system. Further, the 470 cpu has an extra set of "scan-out" circuitry that enables the console mini to check the status of key logic points; it also enables home office engineers to test more than 16,000 different operating points.

The 470's high-speed buffer is said to

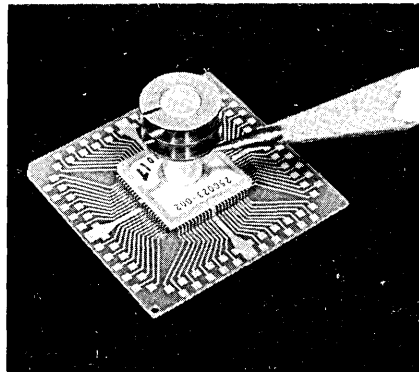

The LSI chips, like this one shown mounted on a pc board for testing, have cooling studs with fins, eliminating the need for liquid cooling like the 370's.

use a "nonstore-through" concept. In both systems, everything accessed from memory by the cpu or the channels is processed by the buffer. On the 370, however, each access is updated both in memory and in the buffer. But in the 470, updates of main memory are performed only when it becomes necessary to move lines out of the buffer.

Further, the 470's DAT box, the dynamic address translation facility to support virtual memory, has a translation look-aside buffer which holds 256 entries—double that of the 370, according to an Amdahl spokesman—and the segment table origin stack has 32 entries, up from six in the 370.

The basic cycle time of the 470 is 32 nanoseconds, as against the 168's 80,

and most instructions operate in two cycles, including a load, load address, load and test, store, retrieve, and add. A fixed point multiply instruction takes seven cycles (224 nanoseconds), and a single-precision floating point multiply requires eight cycles. A fixed-point divide requires 50 cycles, and a single-word floating point divide is 27 cycles.

Using large scale integrated circuits, the Amdahl computer achieves a dramatic compactness, being housed in much smaller cabinets than other comparable computers and requiring fewer boxes on the machine room floor. Within its IC chips, logic circuits that communicate with neighbors on the same chip switch at a speed of 600 picoseconds (trillionths of a second), while those that communicate with circuits in other locations switch at two nanoseconds. Finally, by packing more circuits on a chip, the component count is cut, the number of wiring interconnections is reduced, and reliability is expected to be enhanced.

Late last month, Amdahl Corp. had installed its third system and was expected to announce its shipment plans for the remainder of the year. Significantly, too, word was anticipated on a financing arrangement with a third-party leasing organization, as well as the infusion of additional capital in the manufacturing firm—events that lend much needed credibility to a company that seeks a niche in a rough and tumble marketplace. *

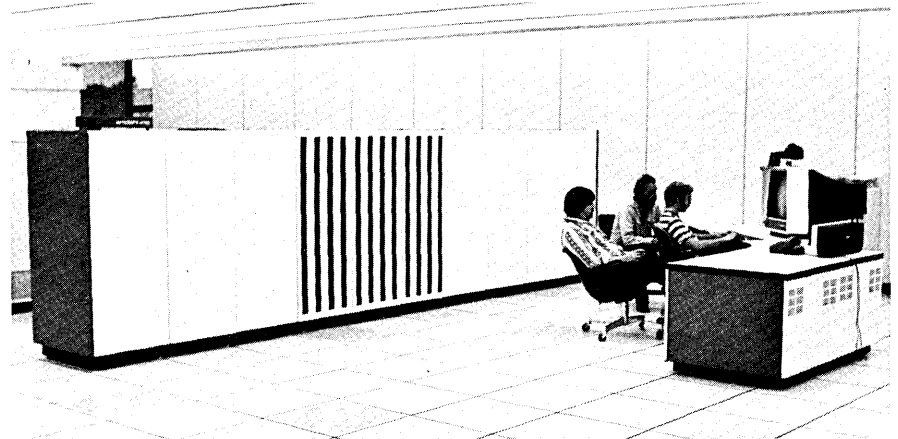

Amdahl's whole product line is the cpu, which is extremely compact, and console. This installation is at the Univ. of Michigan.

Antitrust

The Issue of Bigness

In wake of Telex settlement, other IBM litigants may seek jury trials

Last summer, one of Wall Street's most respected firms, Donaldson, Lufkin and Jenrette, published a research bulletin entitled "What Will the Supreme Court Do in Telex vs. IBM?"

The firm, which had been recommending the purchase of IBM stock, answered the question with a report prepared by Professor Harold J. Spaeth of Michigan State Univ. The political science professor utilized computerized voting statistics by the Justices in preparing his model.

Prof. Spaeth predicted the Supreme Court would support IBM in the case—if the case got that far—by a vote of 7 to 2 on the crucial issue of market share. He went on to note that the two justices who were likely to support Telex—William Douglas and Thurgood Marshall—were ailing and that non-participation by either or both would further enhance an IBM victory.

Prof. Spaeth's report also contained some interesting comments on U.S. Federal District Court Judge A. Sherman Christensen who favored Telex in the initial Telex vs. IBM decision. "I infer," said Prof. Spaeth, "that the district judge reached his decision on the premise that bigness is bad. And that he fit the evidence and read the law to produce this result."

While Prof. Spaeth can easily conclude that a judge who rules against IBM does so on the belief that "bigness is bad," the inference can just as easily be made that a judge who rules in favor of IBM does so on the basic underlying belief that "bigness is good."

Clouding the issues

Furthermore, the basic issue in the various antitrust cases against IBM—bigness—has become so polarized that the actual issues and facts central to the computer industry face the possibility of being lost in the heat of the arguments over whether bigness is good or bigness is bad. For instance, Prof. Spaeth could make his prediction on the outcome of a Supreme Court review of the Telex-IBM case even before the Supreme Court reviewed the case and, indeed, by settling the case before it reached the Supreme Court, Telex itself tacitly admitted that it felt it couldn't win in the Supreme Court.

One thing seems certain in all of this: The Supreme Court—its balance now tipped by the appointees of Richard Nixon—has taken a sharp swing in favor of big business.

Now all antitrust litigants against IBM are in a quandary similar to the one Telex found itself in. If the companies suing IBM win lower court decisions, they must eventually fight their way up to the Supreme Court, usually at great expense, and, once there, they stand little chance, if any, of winning in that pro big business tribunal. What can they do?

"My reaction is that there will be more out-of-court settlements," says J. Thomas Franklin, of the Boston law firm of Sweeney & Franklin. "There is no quick and easy way for a company to fight IBM in the courts now that the Telex case has been settled in IBM's favor." Franklin, an attorney specializing in computer antitrust law, noted that a lower court decision against Telex and in favor of IBM now stands as the final word in the case.

Go to a jury

Some of the firms involved in antitrust suits against IBM have vowed to continue their actions, however. The more important cases are considered to be those filed by California Computer Products, Inc., Forro Precision, Inc., Memorex, Sanders Associates, and Transamerica. The chief new hope for these companies is an anticipated move that they will seek jury trials. The reasoning is that judges are more reluctant to overturn juries than other judges.

"Our case," says an attorney representing Forro, "will be tried by a jury—not a judge—and we're fully confident that there isn't any jury that won't be able to understand what IBM has done in this market." There could be some hitches, however, in attempts to bring IBM cases before juries. In the only IBM antitrust case to date to go before a jury—the Greyhound Computer Corp. case—the federal judge presiding over the case simply blocked off the jury from delivering a decision. The judge, Walter E. Craig of Phoenix, preempted the jury's role and issued a directed verdict himself in favor of IBM, which had not even presented its defense in the case.

Moreover, Judge Craig complimented IBM for gaining its lead in the computer industry as a result of "skill, foresight and industry."

Greyhound appealed the decision and, so far, Greyhound has been waiting for more than three years to get what it wanted in the first place—a jury decision. There is no indication that Greyhound may win or even when the higher court may issue a decision. All this presents a gloomy precedent for the other firms in antitrust litigation with IBM.

Moreover, Judge Craig—like most federal court judges—is the very antithesis of a person who might be expected to sit on a jury. A conservative, he was once president of the American Bar Assn. and his elevation to the federal bench was processed by then U.S. Deputy Attorney General Nicholas Katzenbach, who was IBM's chief legal counsel at the time of the IBM-Greyhound trial.

An example of a way in which a federal court judge can come in contact with opinion partial to big business innocently is evidenced by a March 1974, convention on "Industrial Concentration" sponsored by Columbia Law School. One attendee was Judge Robert H. McWilliams, one of the three Denver judges who overturned the initial Telex-IBM decision in favor of IBM. The conference included IBM among its sponsors and has been described by one observer as heavily slanted in favor of big business. Judge McWilliams attended while he was deliberating on the Telex-IBM case.

The conference was set up by Prof. Harvey Goldschmid of Columbia Law School, whose reports and advice are used by the Wall Street firm of G.A. Saxton to buttress recommendations to purchase IBM stock.

There was nothing wrong with Judge McWilliams attending the meeting but, by the same token, he did not attend a conference sponsored by Telex extolling the benefits of competition. Indeed, there is nothing illegal in any judge having past connections or acquaintanceships with IBM. But the fact that IBM is so big and that so many powerful individuals and institutions have vested interests in IBM—most Wall Street houses for example—largely helps explain the new move toward jury trials by companies involved in antitrust litigation with IBM.

An exception

On the other hand, IBM does not always enjoy solicitous relations with judges. In the Justice Dept.'s antitrust action against IBM, the company has precipitated what appears to be a confrontation with Judge David N. Edelstein. In a petition to the Court of Appeals, IBM seeks to have Judge Edelstein change his stance on some

key procedural matters. In the action, IBM refers to some of Judge Edelstein's actions as "outrageous" and "arbitrary and unlawful." Such charges do not make for friendly relations with Judge Edelstein who is not famed for possessing thick skin to begin with.

Ironically, Judge Edelstein was the choice of IBM to preside over the case. In 1971, IBM's lead outside attorney Thomas Barr made a request that the judge preside over the case, noting that Judge Edelstein had experience with an earlier Justice Dept.-IBM case.

Some see another advantage accruing to IBM in the new Court of Appeals action—the move could take the case off

on a new tangent for months and thereby delay the case considerably. In IBM's last challenge to Judge Edelstein before the Court of Appeals—the issue was over privileged documents—the deliberations dragged on for several months. IBM lost the issue, but only after much valuable time had been expended in the matter. Whatever happens in the various IBM antitrust cases, more attention is certain to be afforded to the various judges and juries—the people who will be making the actual decisions in the cases. This is now particularly so since IBM has made Judge Edelstein's actions an issue in the government case.

—W. David Gardner

Telex vs. IBM: The Risk Was too Great

As the deadline for settlement in the IBM-Telex antitrust case approached, Telex' chairman Roger Wheeler, remained consistent to the very end: he was unpredictable as usual.

At the last possible moment, as the U. S. Supreme Court was preparing the order sheet of the cases it would review, Wheeler threw in the towel and "settled" with IBM, thereby giving IBM its greatest legal victory ever and a potential valuable legal precedent to boot.

The decision of the Tenth U. S. Circuit Court in Denver remains standing. That means that IBM is exonerated of any predatory practices against Telex and, also, that the peripherals industry is considered to consist of scores upon scores of healthy and thriving firms and, further, that it is easy for companies to make dp mainframe compatible peripherals. In return for dropping its case against IBM, the latter firm dropped the \$18.5 million trade secrets counterclaim that it had won against Telex.

While Telex said that Wheeler had initiated the settlement negotiations, there were indications that IBM, too, was interested in settling the case. IBM's chief counsel Nicholas Katzenbach was reliably reported to have been in Tulsa for several days hammering out the settlement. (Marshall Industries, a California firm that had based its IBM antitrust suit on the Telex case, settled with IBM for \$800,000 a few days before.)

One man who did not participate in the settlement was Telex' lead attorney Floyd Walker of Tulsa. Walker, who stood to make several million dollars on the earlier pro Telex decision by Judge A. Sherman Christensen, wanted to see the case go before the Supreme Court.

"Naturally, as a lawyer, I was disappointed that the case didn't go to its final conclusion," said Walker, who declined to discuss the case further. Walker said he is participating in the Transamerica vs. IBM antitrust case, but indicated that he has no plans to pursue IBM in other cases. ("I don't think any

lawyer should make a career of any one industry.")

Privately, however, Walker is said to have told friends he was convinced that not only would the Supreme Court review the Telex vs. IBM case, but that he was convinced the Supreme Court would have overturned the Denver court decision that favored IBM.

Still had a chance

Meanwhile, Wheeler, who had been the reckless buccaneer in suing IBM to begin with, became uncharacteristically timid at the end. Wheeler had more or less gambled everything in suing IBM and many were wondering why he backed down when he still had a chance before the Supreme Court.

In the final analysis, many believe Telex settled because it was hard-pressed for cash, its survival threatened by the \$18.5 million trade secrets judgment against the firm. (Others noted that Roger Wheeler hadn't fared too poorly with Telex over the long haul. Telex financial documents indicate that Wheeler sold 100,000 shares of Telex stock for more than \$1.5 million in 1967 and, in addition, that he had been selling off smaller amounts of Telex stock at high prices over the years.)

With the Telex settlement, IBM may have a valuable precedent it can use in other trust cases. The Justice Dept.'s case, for instance, will examine the peripherals issue and the Telex decision presumably would be valuable for IBM in that case, as it would in other cases brought by peripherals suppliers.

The flaw

But the big IBM victory was flawed somewhat—not by anything in the settlement—but by some internal IBM documents that surfaced a few days before the settlement. Essentially, the IBM documents indicated that IBM itself had found it was expensive and difficult to make computer mainframe peripherals and that revelation seemed to challenge

the Denver Court decision that had favored IBM.

It was jolting news since the decision of the Denver Court favoring IBM had been underpinned by the idea that *all* computer peripheral products "are fully interchangeable and may be interchanged with minimal financial outlay." The court used that argument to reason in essence that the peripherals industry is highly competitive and not controlled by IBM, which is, therefore, permitted wide latitude in actions to put down competition.

The IBM documents struck right at the heart of the Denver Court's ruling that computer peripheral products "are fully interchangeable and may be interchanged with minimal financial outlay."

The IBM documents, which were turned up in another IBM antitrust case, recommended that it would be "bad" for IBM to enter the plug-compatible peripherals industry itself by offering equipment to attach to mainframes made by other manufacturers.

In traditional IBM fashion, the 103-page document examines the "pros" and "cons" of IBM entering the peripherals business. The document, however, indicates that IBM itself would not find it easy or inexpensive to enter the market. For instance, the IBM study indicated that the "engineering cost" per peripheral interface would be from \$250,000 to \$2 million and would expend "12 to 15 man years."

While the IBM document was more or less academic in the Telex case—it wasn't introduced as evidence—it could be useful in other antitrust suits brought against IBM by peripherals makers who seek to vitiate the Denver decision.

—W.D.G.

Retailing

Point-of-Sale: Stiff Competition

The competitive nature of the retail point-of-sale (pos) market has the leading vendor, Singer Business Machines, on the ropes and late entrant, IBM, working hard to carve its niche.

Both facts were quite evident at the 17th annual Information Systems EDP Datacommunications Conference staged last month in New Orleans by the Information Systems Division of the National Retail Merchants Assn. IBM was all over the place. In addition to an elaborate display of its pos equipment, the giant conducted no fewer than four sessions and contributed one of the conference's major speakers, Bob O. Evans, president of its System Communications Division.

Singer was active too but more active were rumors as to who might be going to buy the ailing business machines divi-

MMI Systems announces the first microprocessor that gives you better than minicomputer performance.

The μ MM

Interface Board

The MMI 321/322A/322B board can optionally contain a Teletype or RS 232 interface, along with a high-speed tape reader and tape punch.



CPU Board

The CPU for the System 300 is available in two speed ranges. The MMI 301 offers 300 nanosecond μ cycles, and the MMI 304 offers 600 nanosecond μ cycles. And the entire CPU is put on one 6.6 inch by 9.6 inch board.

MMI Systems, the OEM computer systems division of Monolithic Memories, Inc. announces the μ Mini System 300. Built on the blazing performance and proven reliability of MMI's bipolar LSI products, the System 300 gives you less than 1 microsecond instruction execution time. Not bad for any machine; terrific for a 16-bit microprocessor!

Multiple source software

The μ Mini System 300 is software-compatible with Data General's Nova,* which means your programmers and systems may already speak the 300's language, and vice versa. In addition, there are four completely debugged, commercially available operating systems which will handle program development and mass storage for the System 300. Pick the one you like.

*Trade Mark Data General

Lowest cost today—Lowest cost tomorrow

Take a look at published prices. The MMI 304 CPU is priced at only \$625 in unit quantities. A 16K semiconductor memory to go with it is \$2,100 in unit quantities. Volume discounts extend to 45%. This means you can buy a 16K computer for less than \$1500. Compare it to any other computer, regardless of performance, and see for yourself. We will continue to apply our leadership in LSI semiconductor technology to further reduce the cost of our μ Mini System. This will also provide even better performance and reliability for the systems.

mmi

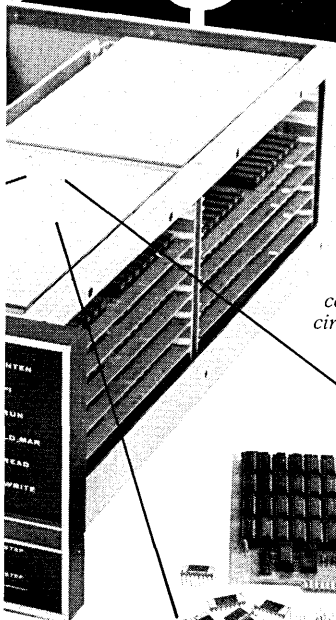

Box

The complete System 300 is provided with a full function, front panel power supply, teletype and tape I/O connectors, a 12-slot card file and an I/O buffer for driving external card cages. The specific CPU memory and controller configuration is at the user's option. All printed circuit boards are 6.6 inches by 9.6 inches.

Memory Board

The System 300 semiconductor memory can be configured in 4K word increments up to 32K words. The MMI 308 provides addressing for up to 32K words, refresh and standby logic, the bus interface, and the first 4K words of memory. The MMI 309 is driven by the 308 and contains up to 16K words per board.

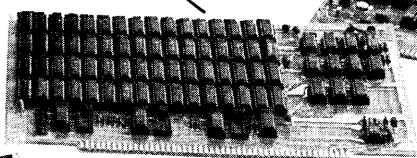

Kit The MMI 300 CPU kit option is available for those who would like to assemble their own CPU. All components required for the CPU are provided along with a schematic of the CPU function.

Virtual Unbundling

A new concept from MMI Systems. Virtual unbundling means simply that we will sell as much or as little computer system hardware as your application requires. Whether your needs call for a complete computer system, subsystem, boards, kit parts, or components, they are all made by MMI and available to you. Who else can match this?

To get your hands on our system, call, TWX or write MMI Systems, 1165 E. Arques Avenue, Sunnyvale, California 94086. Telephone: (408) 739-3535. TWX: 910-339-9229.

Military environment

The System 300 utilizes the latest state-of-the-art LSI semiconductor components, and all μ Mini System 300 components are available with -55°C to $+125^{\circ}\text{C}$ temperature ratings and Mil Std 883 processing. Militarized boards in the System 300 meet all applicable Mil specs, are rated for -55°C to $+100^{\circ}\text{C}$ operation, and include heat rails for conductive cooling and pin and socket connectors for rugged mounting.

mmi 
systems A DIVISION OF
 MONOLITHIC
 MEMORIES, INC.

news in perspective

sion. Singer also contributed a major speaker, George Cogar, new president of the business machines division. The suddenness with which Cogar replaced Richard O. Baily was evidenced by the fact that Baily's name appeared on even the final conference program. Singer sources said the replacement was no surprise within the company . . . that Baily's contract was up as was the time he had been given to turn the company around.

In his first conference appearance as Baily's replacement, as part of a panel presentation, Cogar was obviously unprepared and said little more than "excuse me." He was somewhat more elo-



GEORGE COGAR
Last minute substitution

quent as key speaker at a breakfast session on the conference's final day. "We are an ongoing business," he assured attendees. "We have suffered substantial losses because of our failure to respond adequately to changes in the market place. We are taking steps to correct these mistakes, to concentrate on market areas where we have demonstrated strength, to fulfill our responsibility to our customers and Singer Corporation."

Inherited title

Cogar inherited the title of what was to have been Baily's talk, "The Retail Merchant—Point of Sale in Transition." It might better have been labeled "Singer in Transition."

Aimed most likely at NCR, Cogar criticized the practice of "counting terminals as a score board of progress." He said "a more meaningful yardstick is the number of operational systems installed." And there Singer claims the lead.

The new Singer Business Machines president also is president of the Cogar Corp., a wholly owned Singer subsidiary, and was one of the founders of Mohawk Data Sciences, Inc. He charac-

terized himself as "a technician who likes to solve problems for people, not create them."

Less defensive was NCR's president William S. Anderson, who keynoted the conference and addressed its opening session. He told the retailers that most of the building blocks required for successful POS systems are there. He urged "maximum utilization of current systems and an orderly transition to future systems."

In introducing Anderson, Robert Capone, chairman of NRMA's Information Systems Division and Director of Systems & Data Processing for J. C. Penney Co., Inc., said "retailers are influencing technical developments (in dp and data communications) far more than any other industry."

Technical participation

Certainly there are few vertical industry conferences in which dp vendors participate so actively in the technical program. TRW conducted three sessions, Singer, two, and Sweda, Recognition Equipment Inc., NCR, and Unitote/Regitel, one apiece. AT&T contributed a major speaker, Roger Moody, vice president, industrial marketing. Even Control Data was indirectly involved. CRI Data Services, Inc., a New York city-based company providing computerized point of sale and data management services contributed speakers. Earlier last month Control Data's Service Bureau Co. said it had agreed in principal to acquire CRI.

Although considerable, vendor participation at this year's Information Systems Division conference probably was not as extensive as it was last year when the conference was held in Quebec. Total attendance this year was 850 of which more than 73% were retailers. Of last year's 932 attendees, 44% were manufacturers. The shift in balance toward retailers made Information Systems Division vice president, Irving Solomon, very happy.

What most of the retailers said during the conference should have made the vendors happy. They want more.

Richard L. Abbott of Montgomery Ward told the conference that Wards is adding 1900 NCR 280 terminals this year and after that will add 3,000 terminals per year until all its stores doing \$4 million/year or more in business are on POS via a national teleprocessing network connecting four major centers.

Ray Thomen of the Broadway said his chain now has 14 stores on-line which will grow to 50 stores by 1978.

The little guys' needs are growing too. Jeff Lagum, Webster Clothes, a chain of 50 stores headquartered in Baltimore,

which introduced POS in the summer of 1973, had to upgrade from a system 3 Model 10 with 16K of core to a System 3 Model 15 with 49K early this year.

For catalog stores

Jack Rosenstein, Laventhol, Horwath & Horwath, described a system developed for Catalog Showroom chains by Basco Jewelers which has nine stores in the Philadelphia and Pittsburgh areas. Called "Tel-O-Serve" it is operated under a facilities management contract by a turnkey systems house. Currently it links order desk with inventory and the cashier, making what used to be three steps in the purchase procedure into one. Point-of-sale data capture will be added later. Basco plans to license the system to other catalog showroom chains.

Minicomputer use in retail POS applications is spreading. Bob Koster of TRW told the conference that minis afford flexibility, reliability, and economy. He said they enable retailers to modularize their requirements.

Dan Zatyko of General Automation described distributed data base management systems using minis that can handle up to 250 transactions per second. He called such systems a "challenge to the super computers."

IBM's Jack Carr predicted rapid

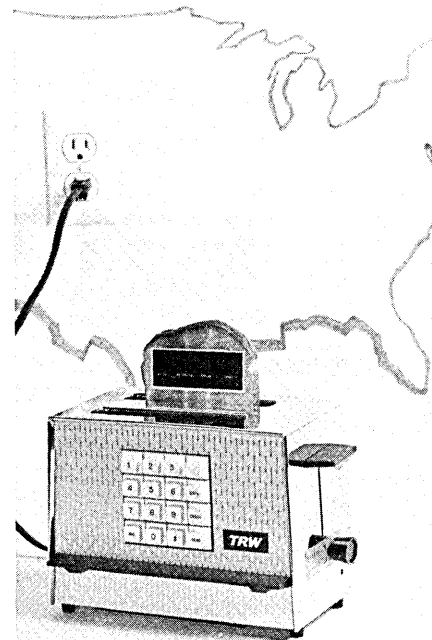

THE TERMINAL OF THE FUTURE: Looks like a toaster, works like a toaster.

growth for the distributed approach to data entry in retailing, not only to the sales floor but to other user departments in the store as well. He predicted this approach will go from 10% now to 80% in 1980.

In a session titled "Fourth Generation, Fact or Friction," Thomen of the Broadway brought those retail systems people who tend to get wrapped up in

Granted, our new ADM-3 is basic. Especially if you compare it with all the smart video terminals around (our ADM-1 or -2, for example). But the \$995 unit price puts it into a different perspective.

As simple as it is, the ADM-3's one-card brain can help you move a lot of data. And it's compatible with most popular computers. That means, it fits all kinds of applications. Including yours.

Here's what you get for \$995. 12" diagonal screen. Full or half duplex operation at 11 selectable data rates. Bright, easy-to-read characters — 960 or 1920,* displayed in 12 or 24 rows of 80 letters. 59 data entry keys arranged like on a typewriter which keeps operator training short and basic, too. What's more, our ADM-3 is alert. It says "beep" when you come to the end of a line. The rest of the time, it just keeps cool and quiet.

Our DUMB TERMINAL also offers you room for

*1920 Characters is an option available at additional cost.

improvements. Its RS 232C interface extension port lets you hook up hard copy printer, magnetic tape recorder or additional (smarter) data terminals. And with a few options, you can make our ADM-3 answer back. Increase its vocabulary by adding upper and lower case. Transmit and receive independently selectable rates. Even enter just numbers on a numeric key pad.

After counting all its limited blessings, you have to admit one thing: you simply couldn't ask for more for \$995. At this low level, you can afford to order a dozen or more DUMB TERMINALS (and buy them at our even lower quantity discount price).

DUMB TERMINAL. SMART BUY.

LEAR SIEGLER, INC.
ELECTRONIC INSTRUMENTATION
DIVISION DATA PRODUCTS



714 N. Brookhurst St.
Anaheim, CA 92803
Telephone:
(714) 774-1010

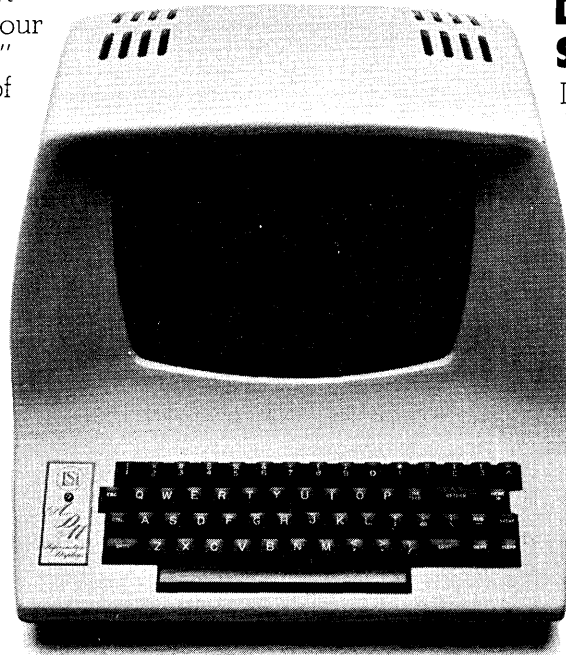

INTRODUCING THE \$995 DUMB TERMINAL.

news in perspective

technology, back to the real world with, "Hey there's a customer out there." His hope for the fourth generation: "happy users."

TRW's Max Beere looks for the day when a retailer will be able to buy a terminal the way a consumer buys a toaster and "just plug it into the network." He knows what such a terminal will look like although he admits "it isn't here now." He even had a picture of it. It looks a lot like an ordinary toaster with a keyboard in its side and a pop-up display which strongly resembles toast.

—Edith Myers

VUVM Takes Off Like a Tortoise

The National Retail Merchants Assn.'s Voluntary Universal Marking Program (VUVM) isn't taking off anywhere as fast as did the grocery industry's Universal Product Code (UPC).

And UPC may well be one of VUVM's biggest stumbling blocks. Many merchandise manufacturers are concerned about double marking as more and more non-grocery items show up with the UPC bar code. The NRMA's VUVM standard is OCR-A. NRMA formally adopted the standard at its Information Systems Division conference last year in Quebec.

Last month, at the division's 1975 conference, it didn't seem as if much had happened in the standard's first year of life although OCR-A was the most talked about topic at the conference.

The VUVM program has as its goal the use of the standard on merchandise tickets by all merchandise suppliers to retail stores. The tickets could be read by optical scanning devices or by the human eye for manual recording or keying into cash registers and POS terminals. The big efficiencies of the program would come through use of scanning.

The big stores seem to like it. The smaller stores are skeptical. They don't feel the 1% increase in efficiency they could get from scanning warrants the investment which would be involved. And they're wary of the long SKUs (stock keeping unit numbers) talked about by some merchandise suppliers. These wouldn't fit into their keying systems.

Some progress

But some progress is being made. Richard L. Abbott of Montgomery Ward told retailers at last month's conference that Wards had just completed a scanning test using Recognition Equipment Inc. wands and OCR-A tickets applied at the store. He called the

results "a substantial improvement over earlier efforts" and said a similar test is being started in a New York store and if results are good "we will get into it (scanning and OCR-A) on a large scale within two to three years."

Management of the bigger stores in NMRA, including Penney's, Sears, Wards, and Federated, developed an idea for a road show to promote OCR-A. Norman Weiser, vice president & treasurer, John Shillito Co. and chairman of NRMA's Merchandise Identification Task Force, said funding and staffing for the effort is now being firmed up.

Recognition Equipment Inc. announced at the conference that it too will develop a traveling OCR-A seminar. REI also announced a media support program in which it will make its media testing laboratory in Dallas available to retailers.

The merchandise suppliers are participating too. Levi-Strauss is about to embark on a test of wanding and OCR-A with NCR and Federated Department Stores, particularly Federated's Foley's of Houston. Merchandise will be ticketed at the receiving warehouse. The test

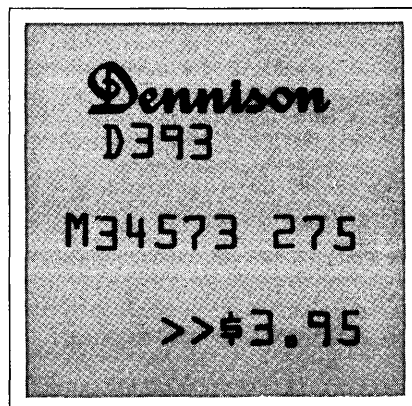

PRICE TAG OF THE FUTURE: OCR-A is an accepted standard but it's not all that prevalent yet.

will cover one department in six stores. Ticketing will begin the first week in February 1976 and scanning, with REI wands, will start in May or June. Lance Campbell of Levi-Strauss said the test has four objectives: 1. to eliminate counting of merchandise on the sales floor; 2. to provide more current, complete, and accurate data to the merchant; 3. to provide real life information on use of OCR-A; and 4. to improve stock/sales ratio. Ticketing will be done using Sovar Co. Model 780 ticket making machines. Foley's POS registers are NCR 280s.

NCR's role

Tom Dodderidge of NCR said his company's participation will include consultation on ticket design; consulting

on test operating procedures; consulting on floor systems design; consulting on data gathering and reporting; evaluation of ticket print quality; installation and maintenance of wand readers; and training sales people in the use of wand readers.

He said objectives of the test are to identify operational problems; to study the effects on internal controls at POS; to correlate results with previous OCR-A tests in laboratory and back office environments; and to establish the effects of OCR-A wand reading in terms of error rate, reject rate and reader reliability.

Campbell, like other merchandise suppliers at the conference, was quick to list for retailers some of the things that have to happen before suppliers are going to be willing to go with VUVM. "Standardization must be supported by the majority of our accounts. Application (of tickets) must be able to be incorporated into the manufacturing flow. Our product identification structure must be incorporated into the manufacturing process which means, in the case of apparel manufacturers, a long SKU number."

He noted that discussions he'd had at a meeting of the American Apparel Manufacturers' Assn. in July showed that few had much knowledge of OCR-A and urged NRMA to "increase the dialogue." Weiser said NRMA was planning to present its OCR-A specifications to the AAMA systems group at a meeting Oct. 29 at Georgia Tech.

Dave Miller of Eden Toys, representing the Toy Manufacturers of America, called VUVM a "major step forward into the 20th century." But, he said, "we want to know what's expected of us and when. What we're saying, respectfully, is hurry up." He said the nature of packaging in the toy industry requires a long lead time for changes to be made. Anything they planned now couldn't be accomplished until 1978.

List of questions

The toy industry, said Miller, didn't learn of the talk of product coding until 1974. Now the TMA has a product coding subcommittee. This group has posed some questions for the NRMA: 1. What is the time schedule? 2. Will vendors have a problem with UPC and OCR-A? 3. Will retailers be using their own marking? 4. What kinds of sales information will retailers be willing to give to vendors? 5. Will NRMA issue detailed specifications? Weiser said NRMA is working on the answers.

Miller believes implementation of OCR-A as a standard offers benefits to suppliers if fully implemented; things like improved inventory management, an ability to forecast for manufacturing and shipping and to decrease production of products that are slow selling, and facilitation of automatic reordering.



“How We Solved The Paper Shortage.”

More than 100 years ago, during the Franco-Prussian war, René Dagon photographed some 1,000 messages on a film two inches wide. He then strapped his film to a pigeon's leg and his message flew to Paris where it was projected by lantern on a screen and read.

That was the beginning of microfilm.

Today's microfilm systems allow you to store information in 1/56th the space you're used to.

1400 lbs. of paper will fit in your hand as 5 lbs. of microfiche.

A warehouse-full of computer printouts can be stored in a single room.

And as paper becomes increasingly more expensive and more difficult to get, the use of computer output microfilm becomes a necessity.

The MMS COM System

It's CalComp's way of putting together a COM printer, a controller with built-in magnetic tape unit and tape-cartridge drive, a keyboard printer, and the software you need for a microfiche management system. It stands alone. It does not require a host computer.

The CalComp system uses either 105 mm. microfiche or 16 mm. roll film. It can reduce images 24, 42, or 48 times. And the output emerges titled and indexed.

Job instructions can be typed in from the keyboard printer. This saves you costly re-programming.

Examine the CalComp system. We think you'll find the best performance for price in the industry.

Call your local CalComp office, or contact California Computer Products, Inc., DA-11-75, 2411 West La Palma Avenue, Anaheim, California 92801. (714) 821-2011.

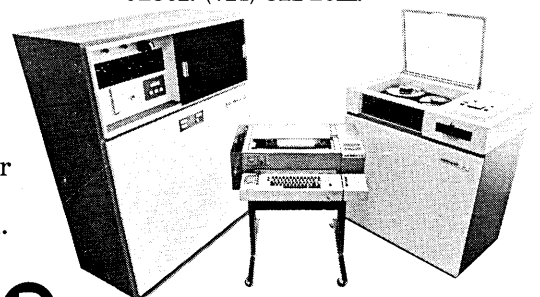

**By the time your
drum plotter turns this out,
a Gould printer/plotter
can turn it out 400 times.**

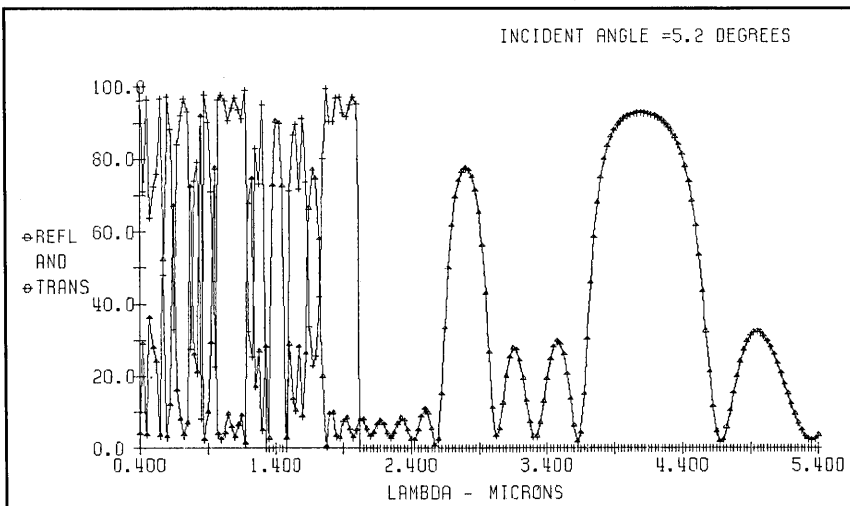

The engineering test data illustrated above was generated on a Gould 5000, on-line to an IBM 370, by ITEK Corporation, Lexington, Mass.

Get higher plotting speed, lower plotting costs, and a useful printing capability in the bargain. A Gould printer/plotter is so fast, it can turn out this plot in only 2 seconds—versus an average 13½ minutes for your old drum plotter.

Our software is upward compatible with the leading drum plotter. Without any sacrifice in mainframe CPU time, or a need to retrain your personnel.

In addition, a Gould printer/plotter gives you a lower unit cost, as well as lower paper cost. And better-looking output, since there's no ink to smudge, clog or run out of. Few moving parts for quiet operation, high reliability.

This all adds up to the best printing/plotting hardware and software available anywhere. And it's backed by Gould's own factory-trained service technicians throughout the world.

To learn more about Gould electrostatic printer/plotters—get in touch with Gould Inc., Instrument Systems Division, 3631 Perkins Ave., Cleveland, Ohio 44114 U.S.A. or Gould Allco S.A., 57 rue St. Sauveur, 91160 Ballainvilliers, France.

For a free full line brochure in the U.S. call toll free (800) 648-4990.

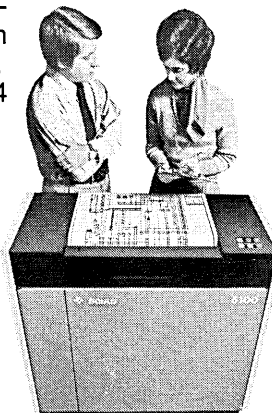

 **GOULD**

CIRCLE 92 ON READER CARD

news in perspective

“Beef this thing up and let's get going,” Levi's Campbell told retailers. “As it stands now, the defensive line's all ready but we don't have a defensive backfield.”

Robert Swett of Kimball Systems, Litton's ticket producing arm, borrowed a line from Delta Air Lines. “Kimball is ready when you are.” He said his company has “invested substantially in the last two years in OCR techniques.” Tom Loemker of Monarch Marking systems was equally enthusiastic about and ready for OCR-A but both Loemker and Swett emphasized that their companies would continue to support other ticketing techniques.

Bad mark for systems

Weiser, in opening a session titled “VUVM—a Status Report,” called it “Quebec Plus One.” He lauded the efforts of equipment manufacturers, merchandise manufacturers, top retail management, and consultants, but accused retail systems people of accomplishing “not much. Nineteen Seventy Six has got to be your year.”

Although pos equipment manufacturers generally are committed to supporting OCR-A, they, like the marking firms, are not ready to abandon other techniques. In his keynote address, NCR's Anderson said his company will continue to offer the NCR color bar code “as long as it remains in demand.”

And not all of the big chains are rushing to OCR-A. Ed Stropin, a regional vice-president of the May Co. was asked if his chain was considering it and his answer was a definite no.

Maybe Quebec plus two will turn up more progress.

—E.M.

Memories

They Write With Ink, Don't They?

Chuck Missler thinks a mass memory system that uses a nonerasable medium may provide the type of data security and system integrity that boards of directors and public accounting firms will cotton to.

“To the extent that data tends to be static or critical, having it nonerasable tends to be important,” he says. “To the extent that nonerasability is important, we've got a shoo-in because we're cheaper, have better performance, and nonerasability on top of that. We should eat 'em alive.”

Missler is the new chairman and chief

executive officer of a resurrected and rejuvenated Precision Instrument Co., Santa Clara, Calif., manufacturer of a laser mass memory system. Last month the company emerged from under its Chapter 11 bankruptcy proceedings and shipped its first Model 190 (16 billion byte capacity) storage device to a Defense Dept. agency in Fort Meade, Md. The agency accepted the unit after a 100-hour evaluation test, during which the 190 exceeded everyone's expectations on error rate, storage density, and transfer rate.

And new money

Passing that test not only solidified the order from the DOD agency but also one from the Energy Research & Development Agency (ERDA), formerly the AEC. It further brought about a permanent



CHARLES W. MISSLER
A question of erasability

investment of \$1.5 million each from Heizer Corp., the Chicago venture capitalists, and Chase Manhattan Capital Corp. And it means jobs for 30 of the 50 people who were locked out of the plant last May when the company ran out of money. Missler subsequently was appointed receiver by the court.

At the time, he headed a management consulting outfit that had made a study for Ampex Corp. of the Terabit Memory program. He says he was impressed by the large scale TBM storage device and equally unimpressed with the non-erasability feature of the product that had got PI into its financial straits. But the more he looked into the laser memory, he says, the more he came to appreciate this unique product.

"The protection you gain by having a file that is physically nonerasable has to be profound," Missler now says. The machine, he adds, must be modified to get it to write over an existing record.

Donn B. Parker of Stanford Research Institute, the computer abuse expert, says, "I would certainly agree that there's an incremental value from the point of view of the retention of perma-

After your 360/370 massages the information, a Gould Plotmaster™ can draw you a picture within 3 seconds.

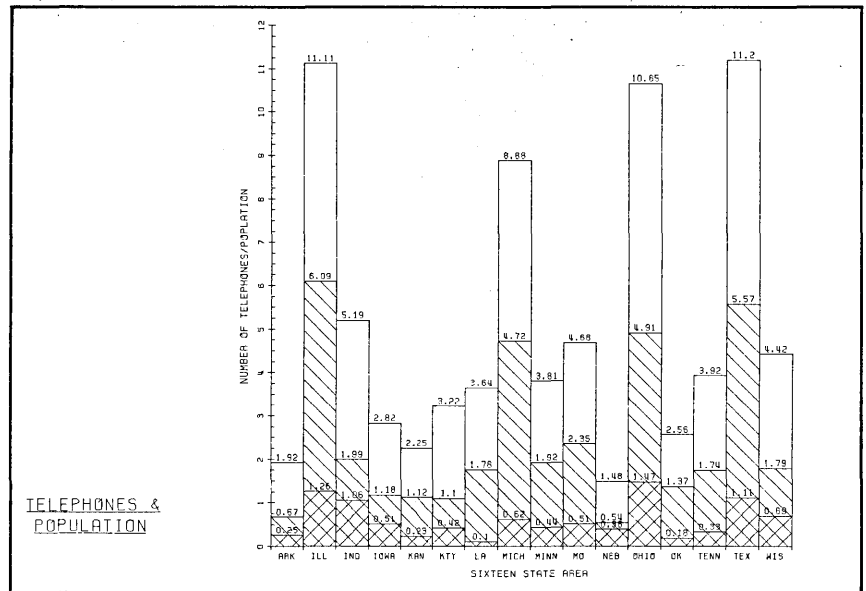

Designed to run on the IBM System/360 or 370, Gould Plotmaster Systems have the power and versatility in both on-line and off-line operation. Without any sacrifice in main-frame CPU time. High-speed printer/plotters have paper widths from 8½ to 22 inches, resolution of 80 to 200 dots per inch, and output speeds of 1.5 to 7 inches per second. And, of course, printing capability.

Easy-to-use software packages like our PLOT package provides background grids, variable line weights, automatic stripping, text annotation and erasure of previously programmed line segments for any geometric construction. DISPLAY™ provides even non-programmers with the capability of easily generating line, bar and pie charts. And with FAST-DRAW™ a Gould Plotmaster can add engineering/scientific graphics and computer-aided design capabilities to your operation.

Get all the facts from Gould Inc., Instrument Systems Division, 3631 Perkins Avenue, Cleveland, Ohio 44114 U.S.A. or Gould Allco S.A., 57 rue St. Sauveur, 91160 Ballainvilliers, France.

For a free full line brochure in the U.S. call toll free (800) 648-4990.

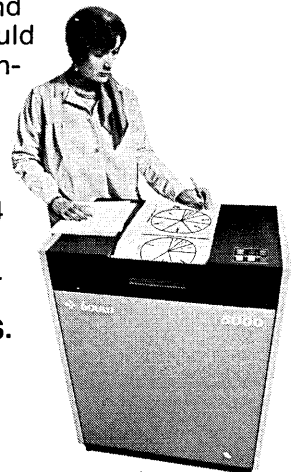

GOULD

CIRCLE 93 ON READER CARD

news in perspective

nent records. It would offer a significantly increased difficulty in modification." But Parker notes there are three dangers faced by the user—the destruction, disclosure, and modification of data. The PI system might discourage the latter, but would be of no assistance in fraud that involved the destruction or disclosure of data.

Comfort for the board

Missler points out that businesses keep records in ink, not pencil. "The concept of having certain files—accounts receivable, for example—in a form that some well meaning computer operator

cannot inadvertently erase is very comforting to a board of directors," says the man who, himself, serves on six boards. He adds that board members are custodians of shareholders' assets, including data bases. Recalling the recent Equity Funding scandal, he says the Big Eight accounting firms, too, are equally exposed and vulnerable.

"That's why I tend to feel that this 'screw' little product that the computer industry for more than 10 years has been laughing at may turn out to be a very important one."

—E.K.Y.

Mainframers

Used Computer Software Charges Changed by Honeywell; Now it's a Stiff License

To sharpen its competitive edge in the used equipment market, Honeywell Information Systems levies stiff licenses on the operating system software for second-hand computers that are purchased from third parties. The licensing policy follows Honeywell's announcement last summer that operating software provided with

computers purchased by customers isn't transferable. That means that if a system is sold, the software cannot be sold with it. Here is an analysis of the company's licensing policy, the reaction of users, and the views of some who have examined the legal aspects.

"The salesman came in and said he made a mistake. I didn't have to pay \$17,500 for my software, just \$100 for a license." Steve Bray, vice president of Syscon, a Kansas service bureau, spoke in wonder of the change in events since last July when Honeywell had shocked him with a new levy on its software used by secondhand computer owners. The operating software on Bray's H-200 was 10 years old. It was unsupported and had been provided at no charge by the local Honeywell office when Bray acquired it from a third party. Then in October, Honeywell returned to admit a "mistake," a big one.

What was not disclosed to Bray was that the Honeywell license plan was merely a modification of the highly-controversial second-user policy that had been announced to some of its users in July. First glance at the modified policy is deceiving because some charges are eliminated for used systems owners who had or were ordering Honeywell software before Oct. 1. These users must sign a license and pay \$100. But those using software that is still being supported must pay a monthly software license for each central processor that is not purchased from Honeywell (see table). Examples: \$350 a month for each O/S2000 and \$500 a month for GCOS 6000, 600 and level 66.

And stiff licenses still are levied on used systems obtained after Oct. 1. These go up to \$50,000 and \$500 a month (for GCOS 6000).

In other words, all owners of Honeywell systems, when it comes to market value, now have Edsels on their hands. They still don't have what they thought they bought. Honeywell feels it has the right to compensation for all it spends on software development; the second user has not paid his fair share. But the question asked in the industry is are they legally entitled to compensation on these particular systems from this segregated cadre of users? Are the original owners also to be penalized? And if there is no legal question, does Honeywell actually gain any compensation, or in fact do they suffer some future losses through alienation of the purchased base? (See accompanying story.)

Some observers raise the questions of antitrust and unfair competition laws, since the policies affect only the used computer market. "The changes only confuse the issue, but do not change the principle of the policies," said a lawyer who has encouraged her client to file charges.

Other legal issues arise from contract questions. Some users have prefaced their comments about the policy with phrases such as "they promised," or "I thought this was always included," or "they never enforced it." Contract lawyers say these statements involve oral representations, common usage, and waivers.

The license

Honeywell never had a software license until 1970. After that time, and until 1975, it made no effort to have used computer owners sign such a license, according to several such users.

WHAT BUYERS OF USED HONEYWELL SYSTEMS MUST PAY FOR SOFTWARE (For hardware bought from third parties)

CLASS 1 OPERATING SYSTEMS (still being supported)	ONE-TIME CHARGE*	MONTHLY FEE**
O/S2000/GCOS level 64	\$35,000 per/cpu	\$350 per/cpu
GCOS-6000,600, level 66 6023, & 6051	\$50,000	\$500
GCOS level 61	\$ 6,000	\$ 60
GCOS level 62	\$10,000	\$100
CLASS 2 OPERATING SYSTEMS (no longer supported)		
MOD 1-TR	\$ 3,000	not applicable
MOD-1-MSR/O/S200	\$ 9,500	not applicable
G-400 DPS/MAPS	\$ 3,500	not applicable
DAPS & TSPS	\$ 7,500	not applicable
DAPS/TSPS	\$ 9,000	not applicable
G-100/200	\$ 2,750	not applicable
H-400/1400	\$ 1,000	not applicable
H-800/1800	\$ 2,000	not applicable
MOD 4	\$15,000	not applicable

*only for users obtaining software after Oct. 1, 1975

**Begins Jan. 1, 1976

Thus, according to some lawyers who commented, the user should not sign the license until he's seen his lawyer. If Honeywell has not enforced its licenses, these lawyers claim, it may have waived its right to that provision in its contract. They add that the user of old software for which there was never a license should examine whether, having been given freely, it is in the public domain.

Signing a license means giving up rights to that software, including its transfer with the system if sold. If Honeywell in fact has no right to licenses on old software and has waived its rights on post-1970 software, it is not due any compensation.

(In a forthcoming book on contracts by consultant Dick Brandon and lawyer Sid Segelstein the "doctrine of waiver" is explained: "... a party's conduct may modify his prior agreement . . . Inaction, even if occasioned by mere lack of attention on the part of a party can have disastrous effects upon a clear and unequivocal agreement.")

The concept of what is practice in the industry may be argued to be applicable in Honeywell's case, according to lawyers we talked to. Honeywell argues that it always retained title to the software and that was the practice in the industry. Users have always felt that when they bought a system, they also bought the "heart" that ran the system. Therefore, hardware included software. In one case—Catamore Jewelry vs. IBM (August, p. 57), lawyer Tom Christo argued that software traditionally was contracted for in an oral agreement. The judge so ruled, allowing this practice to prevail over the written agreement's precise stipulations. So the computer contract may not be the final word.

Charging some

In testimony before the court in the IBM antitrust case, HIS president Clarence W. Spangle seemed to agree with the users' expectations at least up to the time of IBM's unbundling and "immediately thereafter." Asked why HIS didn't unbundle, he said "... we were not certain of the contractual arrangement we had with our customers. We had not in our contracts referred to these items (previously referred to as supporting services, programming assistance to the customer, installation assistance, certain software, certain application packages and certain educational services) as being included or not included, and we were concerned that some customers would feel we had contracted to furnish those, and if that view were to be maintained, we would have been in a position of charging some and not charging others."

Since the standard computer contract has been ambiguous in the past, and HIS admits it the user can argue that either through oral representation or what was

common usage or custom at the time, he understood that hardware went with software. Again, Honeywell naturally has recourse to its own understanding of ownership, exercised through copyright of its materials.

What about the second user? Honeywell will not admit to knowledge of its past practices with second users—whether its employees knowingly gave them software and other materials free of charge without asking for a signature on a license. It said it surveyed the field to find out what its practices were but Honeywell spokesman Joe Keady, a special assistant to the vp of data processing operations, says HIS cannot disclose these results because they are internal and proprietary.

The used market

That Honeywell was aware of the threat of the used computer market at least as far back as 1972 was evidenced in Spangle's testimony at the IBM trial. Documents were introduced in which

marketing executives complained about the used computer dealers (documents also showed that in 1972, HIS was encouraging a conversion of lease customers to purchase). In one memo, marketing executive W. B. Patton recommended a "restrictive second-user policy" to another marketing executive, Chris Lynch. This was in 1972. Then in 1974, Honeywell executives were complaining about high inventories of idle equipment, which plagued them into 1975 and which observers believe led to the July and October second-user policies.

Spangle says he did not know very much about the used computer threat, nor what a second user was, nor the details of the new policies affecting this user. A major architect of the policy, first announced in July, was Dick Douglas, marketing vice president in the U.S. A Douglas memo dated July 11, 1975, referred to the large equipment inventory, especially the 200/2000, and the hot competition with the brokers. (One

Users Bristle at Software Charge Policy

What you buy, you'd like eventually to sell—at a reasonably depreciated price. But owners of Honeywell's 200 and 2000 lines find that what they've bought can't be sold with systems software—unless the seller is Honeywell. For Honeywell in July said that computers sold through third parties can't include the operating software—the buyer must go to Honeywell for the software and pay the price and now a license.

The reaction of 229 Honeywell 200/2000 users, in a recent survey, might be distressing to the "Other Computer Company." Seventy-one of them said they'll take some "action" to ward off the effects of the Honeywell second-user policy changes (the company used to offer the software at no charge to buyers of secondhand computers). In the survey 21 said they've changed their minds about buying a Honeywell computer.

The figures are based on preliminary results of a survey taken by the Midwest Honeywell Users Group (MHUG), which will present them in detail at a meeting Nov. 20 in Chicago.

Nothing changed

The survey was taken before Honeywell modified its July policy to levy only licenses in some cases. So it is not known if the modification has soothed the savaged user. Honeywell user Paul Jarvis, dp manager at Technical Publishing Co., publishers of DATAMATION, said that in his

mind, "nothing has changed" because the charges are still in effect. Jarvis conducted the survey as a member of the MHUG board. Out of 229 users surveyed, Jarvis said, only one had anything favorable to say about Honeywell. That user said, "We should not force HIS (Honeywell Information Systems) to change its policies." He said almost all the others thought a policy change was in order.

The survey of 229 users, some of whom had more than one system, indicated that 119 systems are purchased and 105 are from Honeywell. Eighty are on HIS extended lease, 27 on third-party lease and 46 on HIS rental. The rentals are only about 25% of that base. In testimony in the Justice Dept.—IBM antitrust case, Honeywell's Clarence Spangle seemed to corroborate that most Honeywell systems are owned or leased: 55% are owned outright and 70% of the remaining 45% are on extended lease, with purchase option.

Despite this large segment of users affected now or in the future, Honeywell spokesmen said the company didn't announce to the press its first non-transferability policy because it didn't think that it was significant. It said only two trade publications (one of them DATAMATION) had printed the story. Yet more than 25% of the MHUG users in the survey indicated that they had first found out about the July story through the trade press. *

news in perspective

broker was marketing a G-400 at 5% of list, while HIS price was 40%.) Douglas asked his managers among other things, for feedback on "what type of policies do we need to effectively compete in this market?" What is strange is that Douglas never mentioned the policy he had just instituted which would have a clear effect on those dealers and the used market.

Maintenance policies

The software policy is not the only issue plaguing Honeywell. Users are angry about the maintenance policies, under which HIS will not certify a used system is maintainable until it reaches the new owner's site. They fear, and hence are angry, that Honeywell will try to refurbish where it is not needed at great expense to themselves. Honeywell also has tried to reclaim maintenance manuals from owners who have switched to third-party maintenance.

Gene Merriman, Raytheon Service Co., said he received a flood of calls after HIS began these changes, although not all are attributed to the policy. Some were the usual dissatisfaction many have with their vendors. Raytheon could have a sizable market with the

disaffected 200/2000 owners, but Merriman says Raytheon won't commit its resources until it knows what Honeywell is trying to do to these users—"force them out of existence" or just get them to upgrade.

If maintenance support is tough and expensive for HIS, it isn't doing much to encourage or help Raytheon—evidenced by the manual situation: (*Users should know that Raytheon maintains some HIS systems for the government and GSA contracts stipulate that the HIS manuals go with the system, as long as they are used on that system. The stipulation applies to third-party maintenance of such a system, which must only guarantee non-disclosure or transfer of the material.*)

HIS also has had a spare parts problem, being unable to supply them to Raytheon any faster than 40-52 weeks.

Contract suit

And if all these policy questions aren't enough, Honeywell is being sued for rescission of contract and damages by the company that employs the president of the Honeywell User Group, William White. The firm is a service bureau, Integrated Computer Services,

Inc., New York. The issue has to do with contracts and what the user expected when he bought the system. ICS alleges that Honeywell sold it two 3200s after a proposal and benchmarks said the 3200 would do substantially more than the 1200 it had operated, in fact double the performance. It didn't and ICS sent the system back, demanding its payment and damages.

The standard contract didn't stipulate that performance, only that the system would perform "according to published specifications." ICS said it felt it bought the systems on the basis of the proposal; it claims it could not itself judge expertly whether the bigger system was suitable to its business since its experience was limited to the 1200. Among other guarantees alleged were that its programs would not have to be converted, a statement which in the end was not true. In fact, to achieve the stated performance, the programs would have had to be converted, the company alleged. Its lawyers will have to fight to enter oral representations made by Honeywell salesmen, explain what it contends is common practice in the computer industry, and gain acceptance of the Honeywell proposal as "published specifications." It also will have to establish that the computer user, like the consumer, has no leverage against the vendor who thus

The direct route to
preparation of computer models

SIMULATION PROGRAMMING LANGUAGES

The Most-used Languages World-wide

SIMSCRIPT & GPSS

By the most experienced company
in teaching and consulting
for modeling and simulation

Write for our brochure and course schedules



SOUTHERN SIMULATION SERVICE, INC.
P.O. BOX 22573 TAMPA, FLORIDA 33622
PH. (813) 839-5201

CIRCLE 101 ON READER CARD

Data dynamite.

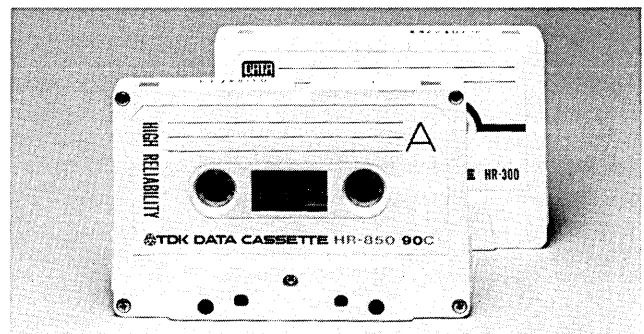

TDK's high-resolution, computer grade data cassettes marry flawless mechanical performance with 100% error free ANSI, ECMA and ISO certification.

Exclusive "SD" formulation eliminates drop-outs and drop-ins, offers a storage density of 800 BPI and 1600 FCI with outstanding physical tape toughness.

Available in three models: the HR 850 series, white and black (100% ANSI, ECMA and ISO), and the HR 300 AW (100% error free but not ISO certified).

Contact us today for full specifications and an "immediate delivery" quotation on both TDK-branded and private-label data cassettes.

TDK®
World's leader in
tape technology.

TDK, 755 Eastgate Blvd., Garden City, N.Y. 11530 (516) 746-0880

CIRCLE 103 ON READER CARD

DATAMATION

must take more responsibility for his claims.

Tom Christo, the young lawyer who fought and won the first round in the Catamore case, is incensed by the standard computer contract and the legal practices in the industry. He feels strongly that the disparity of knowledge between the vendor and the computer user is far greater than that for the average consumer who is more protected by consumer law. Users are fearful that court battles are hopeless, but "That's ridiculous; you have to have the desire to win and the conviction to fight." Cases have been lost because "the judge never fully understood; no one ever told him the issues."

—Angeline Pantages

Electronic Funds Transfer

Study of the Inevitable

There are a lot of explanations floating around for Electronic Funds Transfer Systems (EFTS) and a lot of segments of government and business participating or trying to.

Last month brought forth a new explanation and a new participant. The latter is the long awaited and, by some, never-expected-to-come-to-be Nation-

al Commission on Electronic Funds Transfer. The commission was created by Congress in August of 1974 to recommend action and legislation in connection with the development of public or private electronic fund transfer systems.

President Ford last month nominated William B. Widnall, retired Congressman from New Jersey, to be its chairman. He also announced 13 other appointments to the committee, among them that of Richard D. Hill of Marblehead Mass., chairman of the board and chief executive officer, First National Bank of Boston and past chairman of the American Bankers Assn.'s Payment Systems Policy Committee. Hill was ABA's nominee to the committee of which he said last May "it will be a committee recommending things which will long since have happened (June, p. 107)."

Designing a camel

The new explanation for EFTS, or rather for what's happening with it, emerged during the National Retail Merchants Assn.'s Information Systems Div. conference in New Orleans. It came from Randy Lively of Sears Roebuck Co. who said it's like "designing a horse by committee and that's what a camel is."

A third new wrinkle in the EFTS fabric came last month from Addressograph-Multigraph which announced a new

security technique for the controversial but widely used mag-stripe technique for encoding information on credit/debit cards. Controversy over the technique was over the ease with which it could be read and duplicated.

A-M said its new technique, which can be used at a cost of one cent per card, involves the imbedding of tiny aluminum reflectors on the mag stripe in a random fashion, after identification has been encoded. The distance of each reflector from each data element is recorded and stored in a computer. Such a card, presented for any use, would be read both for the encoded identifying information and for the relative position of the reflectors. The reflectors can only be detected by infrared light. Addressograph-Multigraph said it would license the technique to other plastic card producers.

For those financial institutions which have been leery of mag stripes and receptive to using OCR identification which would be more compatible with retail EFTS thrusts, this could mean a change in thinking.

Examine the inevitable

The new commission will have this and many other divergent efforts to consider. William Anderson, president of NCR, said at the NRMA conference that "EFT on a broad scale is inevitable." He

Talk to us about Terminals

AJ has one of the best selections of computer terminals in the business, backed by our own nationwide sales and service. Take a look at our line-up of quality terminals—

• **AJ 230** The popular Model 33 Teletype with built-in acoustic coupler, plus mobile stand for easy portability. (Also available in auto-answer and TWX/DDD versions.) • **AJ 841** Our original, rugged Selectronic™ terminal. A cost effective replacement for the IBM 2741. • **AJ 630** A solid state, non-impact printer terminal that

offers a 140 character line plus fast, quiet operation. (APL is an option.) • **AJ 830** A new 30 cps impact printer terminal with high print quality. It also features addressable horizontal and vertical tabs.

If you're thinking about terminals, think about Anderson Jacobson. Better yet, write or give us a call and let us tell you more.

**ANDERSON
JACOBSON**

1065 Morse Avenue • Sunnyvale, CA 94086 • (408) 734-4030

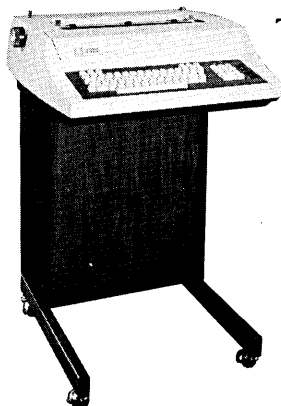

THE AJ 830

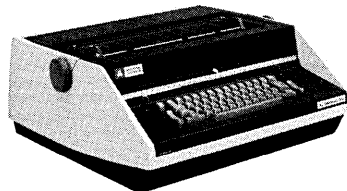

THE AJ 841

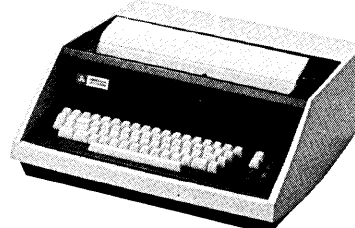

THE AJ 630

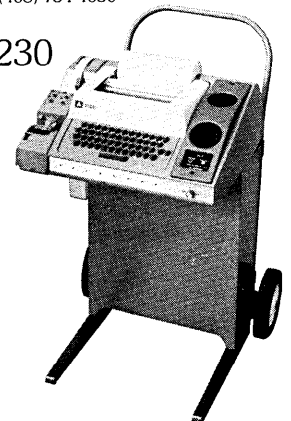

THE AJ 230

The price is right!

NCR Paper announces CM \$print.

**A new carbonless grade designed for
high-volume or stock continuous forms at
a price competitive with carbon & bond.**

(And, of course, no more carbon smudge, removal or disposal.)

Ask about it. NCR Paper breaks the price barrier with a low-cost chemical carbonless paper designed for stock continuous forms. The system is simple, there's only one color (blue), one weight (for each of the CB, CFB and CF grades) and it makes up to four copies. You get the same smudge-free, highly-legible image as with NCR Paper.

Only now, the price is right for high-volume continuous!

Ask your forms supplier about CM \$print or write on your letterhead to:
CM \$print, P.O. Box 359, Appleton, Wisconsin 54911.

NCR *Paper*®

NCR APPLETON PAPERS DIVISION
GENERAL OFFICES: APPLETON, WISCONSIN 54911

news in perspective

predicted a "competitive confrontation between the retailing industry and the financial industry."

Sears' Lively feels current EFT efforts are a "trichotomy" with commercial banks, thrift institutions, and retailers pulling in three different directions. He looks for a shift in credit ownership from retailers to banks but feels that commercial bankers, in developing EFT mechanisms, "have not thought deeply about how to market them."

Asked if Sears had any intentions of getting into the financial or banking business, he answered, "poppycock."

It's this kind of poppycock though that will be the concern of the new EFT Commission. In addition to Widnall and Hill its members are James E. Faris, director, Indiana Dept. of Financial Institutions; William B. Lewis, deputy commissioner, Department of Banking, Savings and Loan Division, state of New Jersey; Gordon R. Worley, executive vice president-finance, Montgomery Ward & Co., Inc.; Verne S. Atwater, president and chief executive officer and trustee, Central Savings Bank, New York; Roy G. Green, president and managing officer, Fidelity Federal Savings and Loan Assn., Jacksonville, Fla.; Herb Wegner, managing director, Credit Union National Assn.; George W. Waters, executive vice president, American Express Co.; John J. Reynolds, president and chief executive officer, Interbank Card Assn.; Freyda P. Koplou, former commissioner of banks, Commonwealth of Massachusetts; Fairfax Leary Jr., professor of law, Temple Univ.; Ralph F. Lewis, editor and publisher, Harvard Business Review; and Almarin Phillips, dean of the School of Public and Urban Policy, Univ. of Pennsylvania.

This all adds up to two from state agencies that regulate banks and other financial institutions; six from specific financial industry areas; and five from outside the financial sectors.

According to the law that created it the commission is to report to Congress on its findings by October 1976. It is expected to be granted an extension. *

Security

Horror Stories Funny, But!

Robert H. Courtney, Jr., IBM's security expert, likes to tell horror stories when he lectures systems people on the subject of data processing security.

He had some good ones for retail systems people attending the National Retail Merchants Assn.'s Information

Systems Division conference in New Orleans last month.

Courtney believes incompetency and carelessness of dp personnel is the biggest security threat. He likes to talk about "the third shift operator who dropped a disc pack just a little bit. Then he tried it on a drive, tried another pack on that drive, then another drive . . . and 15 packs later . . ."

Then there's the story of the night supervisor at a service bureau servicing 70 banks. It's four banking days before Christmas. A tape containing the day's

deposits and checks comes in and is processed but the supervisor doesn't log it. His next shift successor thinks it hasn't been run so he runs it. Double deposits and withdrawals. Lots of mystified customers, some ecstatically happy and some bitter and unhappy. Who's got a program that says "do it over again backwards."

Courtney's big point was that too many dp installations neglect to consider means for proper motivation of employees with the more mundane jobs.

The IBM security expert puts dishonest employees as the second biggest hazard. But, he notes, "People usually rip off the system they know best" which

Like a key, Ruscard opens doors. That's where the similarity ends.

Security access control starts in the parking lot.

The RUSCARD "key" activates parking gates, elevators, doors and entrances of all types. It controls who goes where and when from the moment the employee enters the parking lot. Park-O-Matic is another division of Rusco, manufacturing a complete line of automated parking gates, controls and equipment.

Ruscard systems provide data collection capabilities.

In addition to recording personnel movement the RUSCARD system provides multi-purpose information for use in attendance recording, time-keeping, automated payroll, job cost accounting and more.

Ruscard doubles as a photo ID badge.

The same size and shape as a standard plastic credit card, the cryptically-encoded RUSCARD "key" can be printed and embossed on both sides. It is compatible with Polaroid™ and other ID systems.

It controls access for 1 to 20,000 cardholders, 1 to 100 entrances and elevators, as well!

Keys can easily be duplicated by anyone. The RUSCARD "key" defies duplication. A lost key compromises your entire security system. Then you have to change locks and reissue keys. With the RUSCARD "key" you "rule out" the lost card instantly and it will never open anything again. The RUSCARD system permits positive elevator control, restricting use by authorized personnel as to floor, day and hour of access.

You won't blow a fuse when you hear the price.

Cost is low, just pennies a day! The RUSCO specialist in your area will provide a no-obligation survey of your security needs along with a free RUSCARD Security Guide.

Write Mr. B. Martin, Rusco Electronic Systems, P.O. Box 5005, Glendale, Ca. 91201. Or call toll free: (800) 423-2557. In California call direct or collect: (213) 240-2540. Telex: 696318. Sales and service worldwide.

RUSCO ELECTRONIC SYSTEMS



Division of Rusco Industries, Inc., a listed company on the American Stock Exchange

news in perspective

makes it relatively easy to detect.

In third place he puts fire, but he worries more about fire which denies access to support functions than fire in the computer room. "People tend to put their fire prevention dollars where the money is rather than where the combustibles are." He likes to tell about a customer of his who called him to say "smugly" that he'd installed the latest in fire prevention equipment in his computer room.

"What's under the computer room?"

"Don't know, I'll call you back."

"It's the cafeteria kitchen."

"What kind of fire equipment is there?"

"Don't know, I'll call you back."

"None."

And Courtney likes to tell too of the company which is protecting its records against nuclear attack by keeping tapes in an underground vault some miles from its headquarters. A young messenger, tired, late at night, takes the tape in his car to the fortress. "It's weighing the odds of a nuclear attack against those of an automobile accident."

Last there's the threat from what Courtney calls "James Bond and his cousin, Ivan." This accounts for less

than 3% of security violations, he claimed.

But he had an example. A bank customer in the East called to complain of a faulty communications link. The bank had received a message of deposit from a West Coast bank. It was recorded and the amount was withdrawn. The bank in the East contacted the West Coast bank which denied knowledge of the message. Courtney and helpers made a trip west. They asked who had had access to the terminal at the time the de-

posit message was transmitted. The lady in question was then home sick. She was visited at home. Under questioning she admitted having sent a message for a boyfriend, since departed, as a birthday surprise for an East Coast friend. A check at the bank uncovered a record of the message. It was THE deposit.

"I'd barely gotten home and was ready for bed," said Courtney, "when I got a call from a West Coast bank."

"We have an unauthorized deposit message and the amount has been withdrawn. The bank that sent the message doesn't know anything about it . . ."

Computer crime isn't always computer crime. *

Software

Software Design: A Pisa Perspective

Thousands of tourists visit the leaning tower of Pisa every year to photograph and marvel at the construction oddity. Among the visitors last summer was IBM's Dr. Kenneth E. Iverson who is reported to have called it the original software project.

Iverson, the developer of A Programming Language (APL), was attending the APL 75 Congress in Pisa (October, p. 16)

when he supposedly made the comment which later was published in a newsletter issued by I. P. Sharp Associates, a prominent Toronto APL time-sharing firm.

He said of the tower: "It took 300 years to build and by the time it was 10% built, everyone knew it would be a total disaster. But by then the investment was so big they felt compelled to go on. Since its completion, it has cost a fortune to maintain and is still in danger of collapsing."

"There are at present no plans to replace it, since it was never really needed in the first place."

Suddenly, a small plotter with speed

The first real breakthrough in 12-inch incremental plotters in 15 years.

The Zeta Model 1200. As much as 2½ times faster than other small plotters — with sharply improved line quality.

With operating speeds up to 3000 increments per second at 2.5 mils (1500 at 5.0), the Model 1200 delivers 7.5 inches per second (10.5 diagonal). The standard was 3 inches.

What's more, the Model 1200 is compatible with existing interfaces and software.

Unit cost is low. Attractive OEM discounts are available. If you like fast-moving plots, call or write Zeta Research, Inc., 1043 Stuart Street, Lafayette, California 94549, 415-284-5200.

 Zeta Research

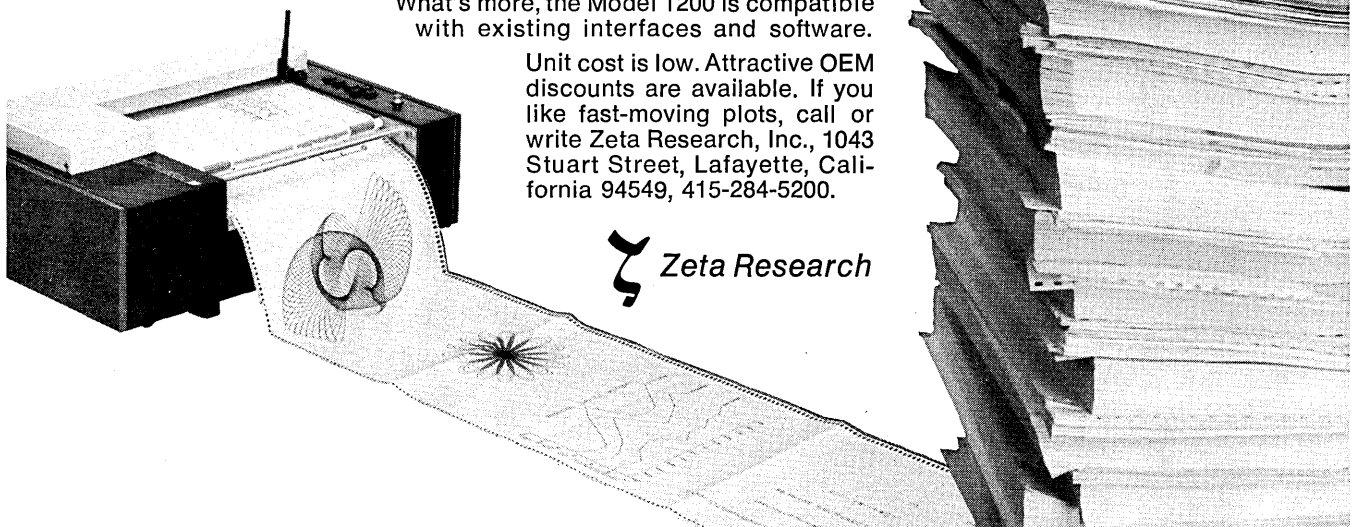



Just plug 'em in and GO.

095/14

Configure your personal computing system using our 9830, our peripherals, our ROMs, our interface cards.



Sales and service from 172 offices in 65 countries.
P.O. Box 301, Loveland, Colorado 80537

Please tell me more about the versatile HP 9830 Computing Calculator.

Information only Hands-on demonstration

Name _____

Title _____

Company _____

Address _____

City _____ State _____

Zip _____ Phone _____

HP Calculator Inquiries, Box 301, Loveland, Colorado 80537

838F

news in perspective

"I expect every installation has its own pet software which is analagous to the above."

Iverson refuses to deny or confirm the accuracy of the published remarks. "I prefer to be quoted on what I write," said the author of the 1962 Wiley book titled "A Programming Language." But he added in a telephone interview: "Almost anything derogatory you could say about today's software design would be accurate." *

Communications

Oh to Be in the South in March

With data communications spending soaring (see following story) more and more persons charged with doing the spending are finding it comfortable to talk it over with their contemporaries in other companies. Which is just fine with the people who rent halls and hotels to get them and their suppliers together.

One of these persons is 42 year old former venture capitalist Sheldon G. Adelson who manages a show and conference called Data Communications Interface. He lists at least four other

such conferences that draw many of the persons in data processing who make decisions about their company's data communications expenditures: The National Computer Conference, The Computer Caravan, the International Communications Assn. conference and exhibit, and the IEEE National Telecommunications conference. And Adelson, who is president of Communication Trends, Inc., Framingham, Mass., said that the people who come to his conference like it best, with the NCC in second place. One of his reasons is the weather.

Last year, when his Interface '74 opened for its second year in Dallas, Adelson asked some of the 1,600 persons who turned out to tell him the best month they'd like to go to a conference of this kind. He said 42.3% told him March, which is the month he's staging Interface '76 (March 29-31 in Miami).

Says Adelson, "People from the northeastern and middle Atlantic states (which according to another Adelson survey represent 40% of the turnout) don't like to travel in February, for instance. It's too close to Christmas and too far away from the spring and the weather is bad." It's also the month that still another data communications conference is being held (The Data Com-

munication Conference and Exposition, Feb. 16-18 in New Orleans) under the sponsorship of the *Data Communications User* magazine which Adelson's company published until it was sold last summer. "Only 8.5% of our attendees like to travel to a conference in February," Adelson says.

Qualifying the turnout

Such conferences are aimed at bringing those who are concerned with data communications up to date on the subject, but the promoters keep a constant finger on the pulse of the exhibiting vendors. The affairs are held by design far away from the areas where the concentration of buyers work (usually in the southern U.S.). "That way," says Adelson, "we create a level of qualification for the attendees." Which is another way of saying that the people whose companies will pay for a winter or spring trip into the South usually turn out to be persons "in sufficient authority to have a decision-making function." That seems to console the exhibiting vendors who pay \$11 a square foot for booth space to sell their wares over a three-day period to crowds such as the 1,200 who showed up for the first Interface ever in 1973 in Dallas, the 1,600 the next year, the 1,200 who turned out in New Orleans last Spring and the 4,000 Adelson is expecting in Miami next March to view the products, ser-

PORTABLE KEY-PUNCH

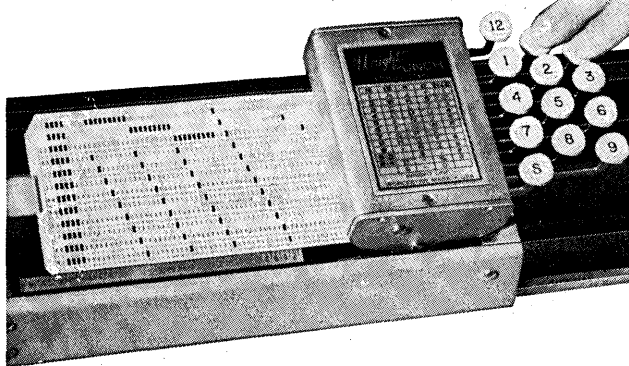

SPEEDS SOURCE DATA ENTRY

Instead of using hand written source data which must go to keypunching before entry, you can punch source data at any location using the Wright Punch. These cards then go directly to data entry.

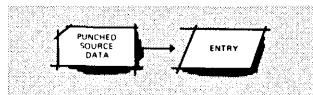
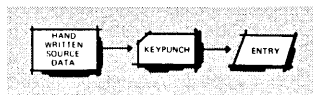

Send today for complete details.

NEW printing model for simultaneous sight verification. Plus manual and electric models for Hollerith punching plastic I.D., badge, and credit cards. Special units considered. Rental programs available in US and Canada.

Dealer and OEM inquiries invited.

160 GOLD STAR BOULEVARD, WORCESTER, MASSACHUSETTS 01606
A DIVISION OF BARRY WRIGHT CORPORATION



CIRCLE 109 ON READER CARD

Noise sensitivity problems go away - we guarantee it!

Topaz Ultra-Isolation Transformers provide an inexpensive and reliable way to supply clean, noise-free AC power to sensitive equipment such as computers, instrumentation, communication and process control equipment.

Ultra-Isolation Transformers offer the industry's best noise attenuation:

- Common-mode noise rejection greater than 145 dB.
- Transverse-mode noise rejection greater than 125 dB at 1 kHz.
- Standard models 125 VA to 45 kVA.
- Priced from \$64.

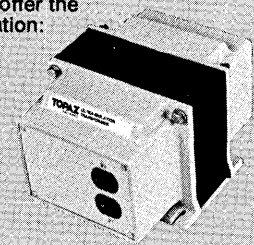

Our guarantee: A Topaz Ultra-Isolation Transformer will solve your noise sensitivity problems to your complete satisfaction or we'll take it back— no questions asked.

TOPAZ SOLUTIONS TO POWER PROBLEMS
ELECTRONICS

3855 RUFFIN ROAD, SAN DIEGO, CA. 92123 • (714)279-0831

CIRCLE 104 ON READER CARD

DATAMATION

VICES and consulting offerings of some 100 exhibitors.

Sponsors of the earlier conference in New Orleans in February are expecting a similar turnout.

Both events seemed to be aimed at the same crowd—essentially the elite in data communications-using companies who have a management problem, preferably that of coping with costs. Theme of Interface '76 is "Managing for Cost Effectiveness Through Data Communications." For the non-technicians the conference will offer a two-day DataComm School in which those wanting

to become familiar with the subject will be briefed during four three-hour sessions. Hopefully, says program coordinator Robert Lively, they'll learn enough to feel comfortable attending the more technical sessions that are part of the 40-session program.

And for those interested in knowing the next best month for attending communications shows, Adelson says his 1974 survey showed that April is in second place as the preference of 20.7% of his attendees at Dallas, followed by May with 12.1%. *

Tomorrow's Dollars Are From Hardware

The telephone company thinks that revenues from data communications will multiply nearly five times during the next decade and that much of it will come from hardware rather than from transmission charges.

W. F. Reddersen, an executive with AT&T in Morristown, N.J., says data communications revenues will grow from \$5 billion in 1975 to some \$22 billion in 1985. That latter figure is about the size of the total revenues of the Bell System in 1973. In the same period, revenues for data terminals will be going from \$2 billion (represented by some 1.3

million terminal devices installed this year) to \$14 billion (6 million terminals, including control units and cluster arrangements).

Reddersen said at a recent San Francisco conference on cybernetics and society, sponsored by the Institute for Electrical and Electronic Engineers (IEEE), that an increasingly larger proportion of the user's data communications expenditures would be going for communications-related hardware, including terminals, and a lesser percentage for the transmission of data.

He thinks transmission switching which accounts for half of today's data communications revenues will represent only a quarter of it in 1985. Revenues from communications processing and

media conversion on the other hand will increase respectively to 25% and 50% from today's level of 20% and 50%.

Another look at spending

A spokesman for IBM's Communications System division, Raleigh, N.C., Ray Kersey, noted in a talk at the conference that the cost of computation had come down by a factor of 1,000 in 15 years. "The 38% average annual reduction in cost can be expected to continue," Kersey observed. He said circuit miniaturization, too, will continue. Others in the past have mentioned the limits of today's optical lithography in achieving much greater reductions in circuit size, but Kersey said electron beam lithography will then take over to permit much higher densities. And at 4 degrees Kelvin, superconductivity is achieved and this (Josephson junction) "technology shows promise of providing circuits 10,000 times faster at comparable power dissipation."

Regarding communications, Kersey noted that the cost per mile of a transmission line hasn't changed much in the last 10 to 20 years, but he cited dramatic increases in available bandwidth. "Further," he said, "communications satellites promise a 40% compound growth rate in circuit capacity per unit cost. This rate rivals that of computing."

He said these cost reductions will

alpha

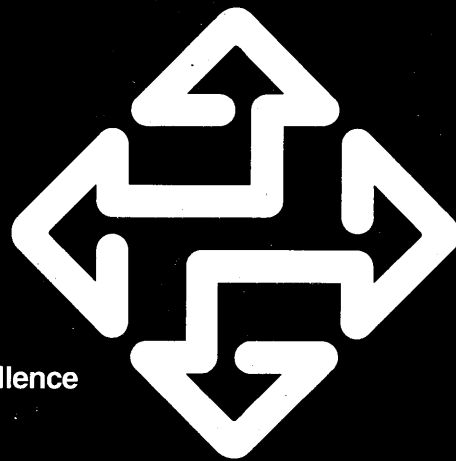

A Standard of Time-Sharing Excellence

The solution to your time-sharing requirements is available.

- A powerful, easy-to-use, non-modal command language.
- Full OS/MVT and VS2 compatibility.
- JCL-less job processing, including batch, remote-batch and interactive program execution.
- Rapid terminal response, even with a large number (50+) of concurrent users.
- Five years of proven reliability.

On COMNETS nationwide ALPHA Time-Sharing service

- A local phone call away in 55 cities from coast to coast.
- Compatible HASP/RJE Service available.
- Professional client support services.

More information on COMNET's comprehensive remote computing capability is available from Lawrence Lawson, Director of Marketing.

On your IBM 360/370 computer system

- Negligible impact on host system performance.
- Functional replacement for IBM's TSO at a fraction of the cost.

Detailed information on ALPHA's capabilities, internal structure and system requirements is available from Ward Clark, Manager of ALPHA Licensing.

COMNET
COMPUTER NETWORK CORPORATION

5185 MacArthur Boulevard, Washington, D. C. 20016 (202) 244-1900

news in perspective

bring about a proliferation of distributed computing. "Those computer communications systems which are today based on a single host, tree structured network architecture will expand into multi-host networks calling for alternate pathing, routing, switching, and more sophisticated control. Those systems which today are based on multiple hosts sharing resources will likely increase in capability to include such functions as dynamic minimum cost, or load leveling choice of which host will execute a given job, and the even more complex capability of shipping different job steps to different machines to optimize resource usage."

Kersey thinks the movement of jobs between computers over commun-

ications lines will be done so at lower cost than via removable media. "The cost of sending a document electronically will predictably, by 1985, beat the cost of mailing that document."

Kersey, indicating how some communications costs have come down, although local communications costs haven't, showed these figures based on Intelsat past and projected charges:

	Intelsat cost/circuit/ year	number of circuits
1965-67	\$22,800	240
1968-71	\$1,800	1,200
1971-78	\$600	6,000
1978-85	\$30	10,000

Standards

IBM's the Standard for I/O Interface

Efforts to develop a U.S. I/O interface standard moved forward in October—maybe.

ANSI's X3T9 subcommittee agreed to adopt IBM's 360/370 interface as the

basis for such a standard. Although the vote was 11-0, three members—who work for Honeywell, Univac, and IBM—were recorded as "not present." They left just before the vote was taken.

On the other hand, 10 of the 11 favorable votes came from members of the Computer Industry Association (CIA), which strongly favors adoption of an I/O interface standard. Eight of the 10 joined only recently. (The eleventh

"yes" vote was cast by an official of the National Bureau of Standards).

A short time after this vote, ANSI's X3 committee decided its X3T9 subcommittee should evaluate the proposed standard against a set of requirements for I/O channel interface criteria that was originally drafted in 1972. An X3 member insists that when the vote on this motion was taken, one individual held up both hands. The final count was 10-9.

The requirements, allegedly, "are so general and all-inclusive it would be impossible to write a standard that embodied them." The likely result, sources said, is that X3T9 will so inform X3, then proceed to convert the IBM interface document into a suitable form for presentation as a proposed standard.

IBM permission expected

This work was supposed to be completed by Nov. 8. By then, the subcommittee also expected that IBM will have granted permission to use its interface as a U.S. standard, and also will have released its related copyright and patent claims for a "non-exorbitant" fee.

X3T9's next meeting is scheduled for Dec. 1-3 in San Diego. Possibly, the preliminaries will be completed by then and the subcommittee will also have voted on the draft standard. The next step would be for the members of X3 to decide—by means of a letter ballot—whether the proposal should be released for public comment. Four months must be allowed for the public's responses, after which the committee votes on the substantive details of the proposal. That takes another six weeks. If the latter ballot produces a "favorable consensus," the proposed standard will be sent to ANSI's board of review for a final vote. Assuming approval at this point, the standard would then be officially adopted.

Mainframes needed

X3 has approximately 47 members—six of whom represent mainframers. Generally, a two-thirds vote constitutes a "favorable consensus." But this term is subject to interpretation. According to a committee source, if all of the mainframers voted against the proposed standard, "there would not be a favorable consensus, even if all the other X3 members were in favor of it." Reason: the mainframers are presumed to have the most technical knowledge of I/O interfaces.

The committee, according to one source, probably would ask the mainframers to explain their opposition in writing, then refer the whole proposal back to X3 for further work.

If proponents of an I/O interface standard are checked at X3, they'll probably submit the X3T9 proposal to the International Standards Organization (ISO),

WHAT IS YOUR TRUE WORTH?

FREE JOB OPPORTUNITIES BULLETIN

Cadillac Associates represents the nation's largest and most respected professional placement service. Our close relationship with the nation's finest firms generates continuous career opportunity information and allows us to confidentially present your qualifications to those at "decision-making" levels.

Our bulletin, published quarterly, listing available opportunities in the Systems & Data Processing field is available free of charge and will be mailed to your home upon your request.

For your free bulletin, without any obligation, circle reader service card #115. Please USE HOME ADDRESS ONLY!

FREE CONFIDENTIAL PLACEMENT SERVICE

If you desire immediate assistance in locating an opportunity consistent with your objectives (professional/financial/geographic), CALL OR WRITE TODAY. A member of our staff of SYSTEMS & EDP SPECIALISTS will reach you by telephone to discuss your objectives and how we might help you satisfy them. A resume, or some details of background, will be appreciated.

Remember: Our client firms are located from coast to coast and assume all expenses (agency fee, interviewing & relocation).



E. W. MOORE
Executive Vice President
CADILLAC ASSOCIATES, INC.*
32 West Randolph St. Chicago, Ill. 60601
Financial 6-9400

**"Where More Executives Find Their Positions Than Anywhere Else in The World."

which is working on a similar worldwide specification. ISO currently is considering a Japanese proposal based on the IBM 360 interface. A source says this spec is favored primarily by the Japanese government. Most Japanese systems and peripheral makers "would be happy" to adopt the 360/370 interface, he contends, adding that the Japanese are willing to provide an organization to administer the standard. This would satisfy an objection X3 has raised in the past to U.S. endorsement of an international I/O interface standard.

—Phil Hirsch

Minicomputers

Computer Store: "Frantic and Fun"

A computer in every home? Not quite but they're showing up in more homes than most people realize, mainly the homes of computer hobbyists.

At the rate the hobby is spreading, it could be more prevalent than stamp (or swizzle stick) collecting by the year 1980. A big reason it's spreading is that computers are getting cheaper. "We feel the home computer is here today at a price many people can afford," said Paul G. Allen, director of software development for MITS, Inc., Albuquerque, N.M. MITS has shipped more than 5,000 of its Altair 8800 computers since the line's introduction last January. These computers, in kit and assembled form, range in price from \$429 to \$621 and they find their way mainly to hobbyists. MITS last month introduced an even lower priced line, the Altair 680, which starts in kit form at \$180 and goes to \$420, depending upon configuration (October, p. 140).

There is no compilation of hobbyists out there with their own computers be they large or small but there is little doubt that the numbers are growing each day. And like most hobbyists, computer hobbyists are banding together in clubs. One such is the Southern California Computer Society, conceived during the past summer and officially launched in September.

"And now a club is born," proclaims the second issue of the SCCS's 16 page newsletter, "a group of computer hobbyists and enthusiasts who are determined to build home systems and share their understanding and dreams with a world which has become dependent upon and soon must become familiar with those fascinating and perplexing machines called computers."

The same issue includes blurbs on the new club's officers and directors. It would be impossible to stereotype a computer hobbyist from reading these. There are engineers, programmers, accountants, a superior court judge, and

a high school sophomore, Chris King, "who is trying to bring up full duplex on his school's Interdata 16" and has been "into computers" since the seventh grade.

And there's Lois Heiser who, with her husband, Richard, is running what probably is the country's first retail computer store. Richard sees the popularization of computers as a hobby as

Commercial 8714 Pisner oil groover Mod. 1-A 4157283-1854	Electronic Equipment 8831 WAVE soldering system, 12" elec. trovert, foam filter, pre-htr., 220V, 3 phase, 1 yr. \$3500. 764-0934	CA Upcomin Times Clar Oct. 11-12- & Fe show group Costa 10/12 10-6 P
Move 8719 Bdrm. 1 1/2, 1/2 bath, 1/2 car, 1/2 Hardwood Flrs, 40' x 40' lot, 1/2 Ideal guest hse. 100% financing Movers	AN/COM Electronic Surplus 5667 Lenkerstun, N.H. 213-759-5518 * ALTAIR 8800 COMPUTERS * The Computer Store 478-3168	Oct. 14--F come come
& Family Room CED AIR HEAT. FITS 50 FT. LOT. 665-1221	Indust. Equip. & Mat. 8837 14x50' STEEL balcony, w/1 1/2" TNG elwood floor.	

It Pulls! This two line ad is bringing computer fanciers from all over Los Angeles to The Computer Store.

a "rising tide" and "I want to rise with the tide coming instead of being squelched by it."

So far, it would seem, he's been doing it. "The Computer Store" opened its doors to the public on July 16. It's a non-prepossessing storefront among numerous equally non-prepossessing storefronts at 11656 Pico Blvd. in West Los Angeles. It used to be headquarters for an outfit that sold vibrators by mail.

The Heisers grossed \$10,000 in their first month of business on more than 100 individual sales. They carry Altair

8800 in both kit and assembled units, Altair parallel, serial RS-232, Serial TTL, and Serial TTY input/output devices, and Altair memory (1K and 4K boards).

They also carry books including: *Basic*, by Albrecht, Finkel & Bron; *Basic Basic* by James Coan; *Computer Lib & Dream Machines*, by Theodore H. Nelson; *Dragon Shirts*, by Nancy Hertert; *My Computer Likes Me*, by Dymax; and *101 Basic Games*, by David Ahl. Altogether they stock 30 titles with an average of 12 copies per title.

What's a computer store?

"Most people who come in go first to the books," Lois noted. "It gives them a chance to become comfortable." Otherwise, said Richard, "they'd be tense and so would we." The tenseness derives from the fact that few people, including the Heisers, are entirely sure what a computer store is or should be. But the Heisers are learning. "It's more like an auto dealership than a camera shop," says Richard. "You can't afford to stock a lot of competing lines and you have to know all about the product line you do stock."

The Computer Store was fast aborning. Richard Heiser got the idea for the store in May. They had an agreement with MITS by June 26, and opened their doors in mid-July. "But," notes Lois, "Richard has been thinking in terms of

LINE PRINTER NOISE!



Sound familiar?

When you have chatterboxes like teletypewriters, line printers, and automatic typewriters, you have a noise problem. Get rid of the racket with a Gates noise-cover for each machine. Acoustically effective, functional, and we have 250 models to fit just about every office noisemaker. For information, call us toll-free. Do it right now, before the noise drives you crazy.

Call (800) 358-8265

In California call (707) 544-2711 (collect)

GATES

BOX 1406, SANTA ROSA, CA

capable of buying components and putting a computer together from scratch but they want to get experience with a kit first."

Their promotion so far has been minimal yet "there are at least three people in here at almost all times and often many, many more." The store is open from 2 p.m. to 8 p.m. Wednesday through Friday and from 10 a.m. to 6 p.m. Saturday and Sunday. Wednesday is their busiest day. Peak period is after 5 p.m. They have an Altair 8K Basic language system hooked up to a Teletype which they use for demonstrations and on which they allow customers to play games.

Playing games

The Heisers say most of their computer customers are buying computers to play games. "They admit this sheepishly," says Lois. "It's a little too soon for practical home applications but I see this evolving within the year."

"Peripherals are a problem now," Lois said. "They're so expensive. We're looking into inexpensive means of input/output for the hobbyist." One such they're now offering is a television/type-writer interface which enables a hobbyist to use his home tv set as a crt. This costs him \$280. That's exclusive of the cost of the tv set, of course.

The promotion the Heisers have done

has included mailings of two separate flyers and a classified advertisement in the *Los Angeles Times* under the heading "electronic equipment."

In their initial investment they were helped by both their parents. "I went to a banker," said Richard, "but he told me to come back after I'd been in business for a year." Their initial stock of some 10 systems was based "on what we could afford."

Lois and Richard met in 1969 when both were working for Rand, she in simulation modeling and he as a computer systems analyst on medical projects.

The store wasn't the only thing they leapt into fast. In 1971 they made a decision in two weeks time, to leave Rand and go to Germany where both worked for infas, an opinion poll and election night forecasting company. They stayed there about a year.

Lois is a math graduate of the Univ. of Colorado. She worked for six months after graduation as a computer aide at the National Center for Atmospheric Research in Colorado, then went to Rand where she worked almost continuously until last month except for the stint in Europe and six months as a programmer for Philco Ford after returning from Europe. "I felt the woman thing there for the first time," she said. "I wanted to get back to Rand." She did and will continue as a consultant to

Rand while helping to run The Computer Store.

Richard was graduated with a degree in chemistry from Rice Univ. in Houston, Texas. His first job after college was with IBM as a systems engineer. "I didn't know about computers." He learned some at IBM, more at Douglas, his second employer, where he worked with large systems. "But I got all the theoretical stuff at Rand." Richard's job after Europe was with Perlec Corp. as International Manager for Microfilm Software Support "because of my international experience." He stayed there two years then went to Litton.

His entrepreneurial instincts go way back. In the spring of 1974 he formed Arrowhead Computer Co. and purchased a Computer Automation Alpha minicomputer with the intent of developing a system with text editing capability. He found it would be prohibitively expensive for the market he was aiming at. "I should be doing it now, not a year ago." He's going to—but on an Altair, not the Alpha although they still have it. It's sitting in the back of the store.

Across the street from the Heisers' store is a small restaurant with outside tables. Patrons "see our sign, come over, and laugh," says Lois. The Heisers aren't laughing. They're riding a tide that doesn't seem likely to squelch them.

—E.M.

The transaction terminal that's backed by Varian world-wide.

For over two years Varian's T-Scan terminals have processed Brazilian Stock Exchange transactions valued at more than \$50 billion — without a single processing error. That's the type of performance and reliability that T-Scan users can expect in every country served by Varian world-wide.

From processing customer orders to grading student examinations, from handling lottery and betting tickets to controlling inventory the T-Scan terminal is proving to be the economical and simple solution to computer processing of orders, reservations, and other data.

T-Scan is flexible . . . it can be used by anyone with little or no training, including your customers . . . it can be used with virtually any computer, large or small, even in conjunction with other types of terminals . . . and unlike other computer terminals which normally require one terminal per operator, each T-Scan terminal can be readily shared by ten, twenty or even more people.

Why not investigate T-Scan — the Canadian designed and manufactured terminal that's backed by Varian world-wide.

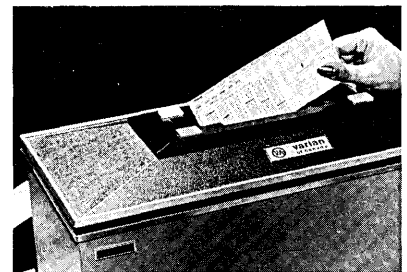

Phone or write to-day for full details.



varian canada
Peripheral Products Division

45 River Drive
Georgetown, Ontario L7G 2J4
(416) 457-4130

12062 Valley View St., Suite 208
Garden Grove, California 92645
(714) 894-7530

News in Perspective

BENCHMARKS . . .

For the Xerox Users: While Honeywell Inc. and Xerox Corp. work out details of a transaction under which Honeywell would assume responsibility for servicing and marketing support for the Xerox Data Systems customer base, other forces are at work which could seriously erode that base before the arrangement becomes effective. Tymshare Inc. has beefed up its Valcomp Div. which offers maintenance, refurbishment services and replacement parts to Xerox computer users, with the acquisition of a competitor, Quelex Inc. The combined operation is reported to have identified the major blue chip high dollar level Xerox users and is aiming at them, probably with prices that would undercut Honeywell which would have to share some of its revenues with Xerox should the agreement go through.

Then there's Telefile Computer Products, Inc., Irvine, Calif., which tried to talk to Xerox about acquiring manufacturing rights, its base of leased computers, and maintenance contracts but got only what Telefile president, Sam Edens, called "frustration and dismay." Now Telefile has embarked on a plan "to purchase the entire lease base and all of the maintenance contracts on our own, directly from the users." The company is offering: up to 55% of purchase price for Xerox Sigma 3 and Sigma 5 cpu's; up to 66% for Sigma 6s; up to 77% for Sigma 7s; up to 88% for Sigma 8s and 9s; and up to 60% for 530s, and 73% for 550s and 560s.

Business is Good: Generally, it's been a good year for the computer mainframe manufacturers as measured by recently-released quarterly financial reports. IBM said its third quarter income of \$3.6 billion was an increase of nearly \$475 million over the same period last year. Its earnings of \$495 million were nearly \$18 million ahead of last year. Worldwide inflation, however, trimmed its nine-month earnings increase to a modest 1%, but the total nevertheless was at a record high. Control Data reported a \$5.1 million profit in the third quarter for its computer business against a loss of \$13.9 million a year earlier, much of the increase being due to gains in rental and services revenues. Computer revenues in the quarter increased 8.8% to \$310.2 million from \$285.2 million the year previous. Honeywell's computer revenues of \$192.6 million in the third quarter soared 11.7% ahead of the year previous. NCR Corp. said its third quarter earnings dropped slightly from the record \$19.9 million in the year-earlier period, but that was due in part to uncertainties in two big markets

for NCR: electronic funds transfer systems and supermarket checkout systems using scanning devices. Sperry Rand's Univac division said its computer operation's revenues rose 10% in the first half of its fiscal year and that its backlog of orders had risen 11%

From Russia and China: Control Data Corp. has received big computer orders from Russia and China. Russia has ordered a \$10 million Cyber 76 for use in a weather-forecasting center. China's order was for a Cyber 72 system valued at \$4 to \$5 million for use in seismic analysis to aid oil exploration. Applications for export licenses are pending with the Commerce Dept. which controls shipment of advanced technological equipment to Communist countries. If the department approves, the applications then go to Cocom, an international committee made up primarily of North Atlantic Treaty Organization member nations. Control Data president, William Norris, said past experience leads him to believe it will take a year or more for the government to act on the applications.

ICL Joins CPI: After more than three years of thinking it over, Britain's International Computers Ltd. signed an agreement with NCR Corp. and Control Data Corp. to eventually acquire a one-third interest in their joint venture firm, Computer Peripherals, Inc. ICL's initial purchase was of a one-sixth interest for \$8.6 million. Control Data and NCR founded CPI in 1972. With its new partner, CPI has established a subsidiary in the United Kingdom called CPI Data Peripherals Ltd. This subsidiary initially will undertake research and development activities and plans ultimately to manufacture peripherals in the U.K. for one or more of CPI's shareholders. U.S. operations of CPI are headquartered in Edina, Minn.

"Understandable but Unfortunate": The Computer Industry Assn. has labeled Telex' out-of-court settlement with IBM "understandable but unfortunate." The CIA called it "a sad situation that any time a small, independent computer company, such as a Telex, takes on the Corporate Goliath, the grossly ill-matched sides usually make an outcome such as this highly predictable—and yes, even understandable. Telex could in no way gamble on an \$18.5 million loss; IBM would never miss an \$18.5 million gain." The association cited as "particularly unfortunate" the fact that the decision by the Tenth Circuit Court of Appeals will be allowed to stand uncontested. "The recent discovery by Telex of an IBM study on whether IBM should be in the plug-compatible business clearly indicates that even IBM is well aware of the flaws in

the appellate court's decision." Calling the settlement "a gross miscarriage of justice," CIA president Jack Biddle said "it is more urgent than ever that we seek resolution of the industry problems and misconceptions in the Halls of Congress. That route now appears to be the shortest course to justice."

Bid Rigging Charges: IBM is facing criminal charges in Hudson County, N.J., following its indictment along with five individuals on charges of conspiracy to violate the state's contracting statute. Individuals indicted were Peter Korn, former Jersey City business administrator; Joseph Cahill, former city finance director; Walter Hapell, former city director of data processing services; Roger Forsyth, with the First Jersey National Bank, and Eugene Josephs, an IBM sales representative. The case involves an alleged conspiracy in 1973 and 1974 to evade the state public bidding law in award of a \$13,960 computer rental contract and to close Burroughs Corp. and Honeywell Inc. out of the bidding. The six count indictment lists conspiracy, and three counts of misconduct against Korn, Cahill and Hapell. Four unindicted coconspirators also were named including three IBM employees, William Binch, Scott Fencher and Thomas O'Connell. IBM expressed "shock and surprise" at the indictment claiming "there are absolutely no facts" warranting the conspiracy charge. The giant conducted its own investigation and said it believes "IBM personnel may have gone too far in an intensive and overzealous sales effort . . . (but) there are absolutely no facts that could lead any reasonable person to conclude that an indictment of criminal conspiracy against IBM was warranted."

Rodgers' View: The proliferation of very small and very big computers isn't going to shrink the market for medium scale computers, says F. G. "Buck" Rodgers, IBM's marketing vice president. Rodgers, former president of IBM's Data Processing Div., says new computer users will move from their small machines to medium scale equipment. In answer to questions following a talk in Palo Alto to the trade association, WEMA, Rodgers also noted that computer users are devoting more of their dp budgets to software than hardware. He said that by the '78-'79 period, spending for hardware may represent only 35 to 40% of the total budget. Users, he added, still are spending some 70% of their effort maintaining old programs when they should be spending 75% on new software. He also foresees corporate users doing more computer modeling and envisions advancements soon in medical/health systems, law enforcement systems and in teleprocessing. *

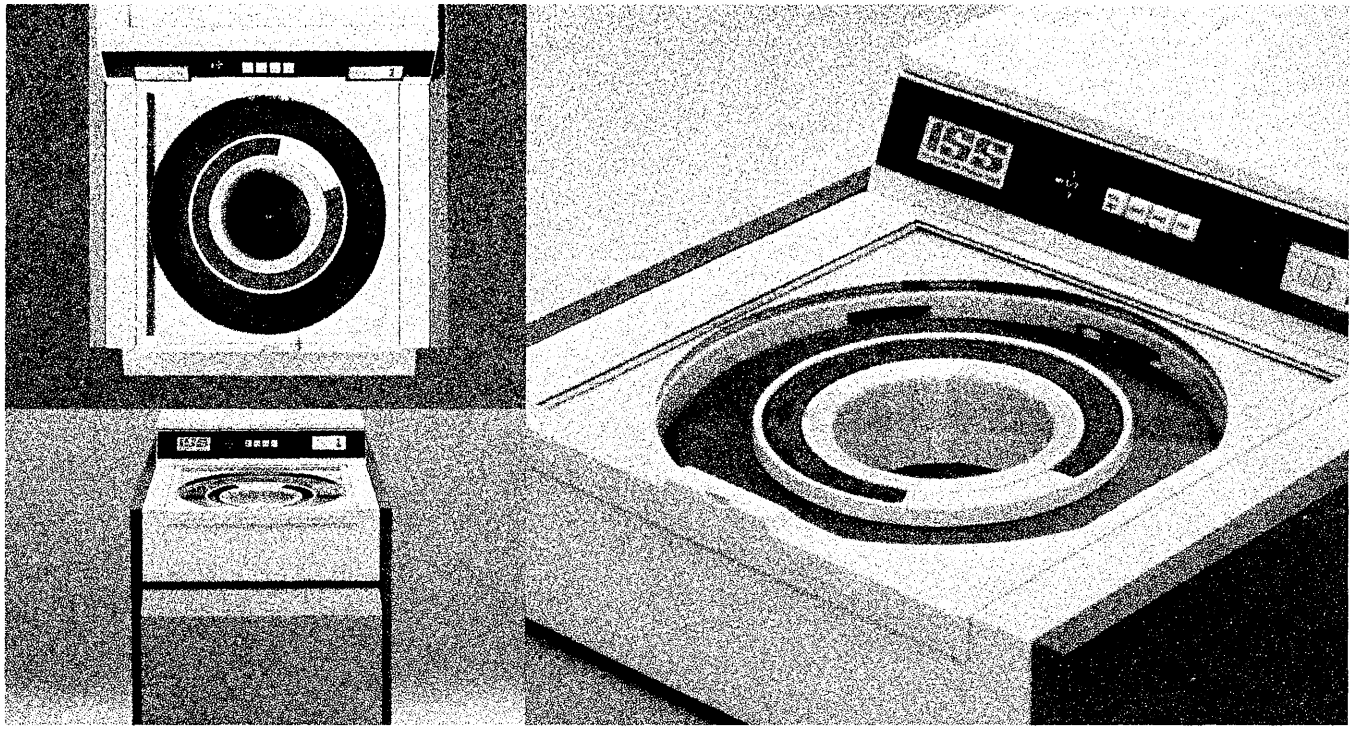

Seven reasons why ISS 7330-11 is the preferred disk drive.

A new price-performance leader from the leader.

The 7330-11 is an increased performance version of the ISS 7330, the world's most widely used independent 100-megabyte disk drive.

The amazingly compact, super-quiet 7330-11 offers near-instant access to a 200-million byte capacity. Access time is 27 milliseconds average, and start-stop time just 15 seconds.

The 7330-11 is another example of the technological leadership that has made ISS® the leading independent manufacturer of disk storage systems.

Designed to grow.

If your customer's immediate storage needs don't require a 200-megabyte drive, he can start with the ISS 7330-10. It has the same advanced features but only half the capacity. But as needs grow, so does the drive—it's field-expandable to 200 megabytes. This means storage capacity can be added when needed, and a cost-efficient system can be maintained.

- 1. Capacity Flexibility** — ISS 7330-11 gives you 200-megabyte capacity from the start, or you can select the 100-megabyte 7330-10 which is field-expandable to 200 megabytes when you need it.
- 2. Exceptional Speeds** — fastest positioning available (27 milliseconds average) and rapid start-stop time of 15 seconds.
- 3. Compactness** — all this power comes in a unit measuring just 22 x 34 inches.
- 4. Operator Convenience** — easy pack loading at waist-high 36-inch level.
- 5. Silent Operation** — this is easily the quietest disk drive in its class.
- 6. Dependability** — the unit is already setting new industry standards for reliability.
- 7. It's manufactured by ISS** — the leader in designing and building innovative, dependable and cost-effective disk storage systems.

ISS support — 24 hours a day.

ISS maintains a complete support facility for all customers. Spare parts and technical assistance are available round-the-clock, across the country.

When you buy a disk drive from ISS, you're getting a lot more than a disk drive—you're getting a company that supports you 24 hours a day.

Write or call us today.

We obviously have much more to say about the new ISS 7330-11 and the reasons why it's the preferred disk drive. If you are an OEM/PCM supplier, we would like to send you a brochure or talk to you in person. Call or write us today. 10435 N. Tantau Avenue, Cupertino, CA 95014, (408) 257-6220. ISS is an operating unit of Sperry Univac.

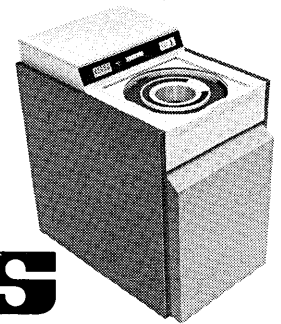

ISS

Technological leadership for the generations ahead.

Sperry Univac is a division of Sperry Rand Corporation

LOOK AHEAD

(Continued from page 18)

petrator could be realizing as much as \$300,000 a year. Whatever is happening is still happening. The bank (preferring to remain anonymous) told Parker that the Controller of the Currency, the Federal Deposit Insurance Corp. and the Federal Bureau of Investigation have taken an interest in the case. But the bank's own losses are not great enough to warrant a massive expenditure on any kind of investigation. It wants a simple solution.

MORE WAYS THAN ONE TO SKIN A CAT

Can a small software house take on a big conglomerate and win? Maybe. Especially if it gets help. M. Bryce and Associates has been offered help in a suit against Harley Davidson, a subsidiary of AMF Inc. by the Assn. of Data Processing Service Organizations. The Milwaukee office of Harley Davidson asked Bryce to make a presentation on a software package, PRIDE, and to permit representatives of its accounting firm, Arthur Young and Co., to be present. Bryce agreed on condition everyone involved sign a non-disclosure agreement.

Bryce made a five hour presentation after which Arthur Young told Harley Davidson it could do the same job cheaper. It came up with a procedure that would produce exactly the same output Bryce's package would have produced. Bryce filed suit against Harley Davidson and Arthur Young & Co. charging theft of trade secrets. Harley Davidson has countered that Bryce, although it did not have a registered copyright on PRIDE, had put a copyright symbol on its package which precludes trade secret protection. ADAPSO wants to get into the act with the argument that Arthur Young used incremental marketing techniques, using its leverage as Harley Davidson's accountants to get other kinds of its business.

NINE MONTHS IN SEARCH OF A PACKAGE

Sundstrand Corp., Rockford, Ill., may have some kind of a record for thoroughness in evaluating software packages. George S. Hoyt, who represented users on a company project to overhaul its manufacturing management system through packages, says it made a nine-month study before making a decision on a package. From March to November in 1973, his team evaluated 10 packages, visited 35 companies, traveled to seven nations and 17 states and met with more than 130 non-Sundstrand managers.

Some advice: don't be reluctant to talk to others with similar experiences when evaluating a software product. They're eager to help. And don't take too seriously those who say your company is unique and therefore cannot use a package. Problems from company to company are impressively similar. "In fact," says Hoyt, "I believe that the problems are 80% common."

ROBERT REDFORD WAS AHEAD OF HIS TIME

For those who saw Robert Redford in "Three Days of the Condor" and are wondering where you can get a Digital Equipment system like the one in the movie, the answer is nowhere. In the movie, the minicomputer system--a PDP-8/e and a DECwriter--is used to translate Chinese to English by the Central Intelligence Agency. The mini-system was programmed with DEC's high level language FOCAL to simulate language translation. The real thing--a mini system that would front-end a larger translation system--won't be available for at least five years, the experts say.

RUMORS AND RAW RANDOM DATA

Anyone wanting to get into the Polish software market should get to know Stanislaw Soltysinski, currently a visiting professor of law at the Univ. of Pennsylvania law school and also a Polish official with a charter from the Polish government to seek out one or more top U.S. software houses to get a joint venture or partnership going in Poland...ADAPSO last month issued a position paper stating that Congress should not grant an extension to the reporting times for the newly named EFTS Commission (p. 135) unless a person or persons with special experience in the computer industry are added to the commission...The industry is buzzing about the new Cogar/Stitz combination at Singer Business Machines (p. 123). People here know who Cogar is--founder of Cogar Corp. and a millionaire. But who's Otto Stitz--the man just named to replace Gordon Smith who quit as Singer's overseas marketing head? Stitz, well known in Europe, guided Mohawk Data's overseas operations to a profitable business in 55 nations. Stitz, Cogar and Smith were all together at Univac in earlier days, Stitz having been general manager of Univac, West Germany.

ANOTHER PAGE FROM TALLY'S RELIABILITY STORY

Consistent print quality line after line.

Steadfast reliability. A 200 line per minute printer you can drive as hard as you want without fear of failure. A line printer that assures you consistent, unwavering print quality and line registration.

Reliability made possible by the unique Tally comb matrix print technology. A technique that eliminates wear and tear while delivering "locked-in" precise print registration. You get straight lines all the time. You get clean and consistent print quality all the time. And with no preventative maintenance except for routine cleaning.

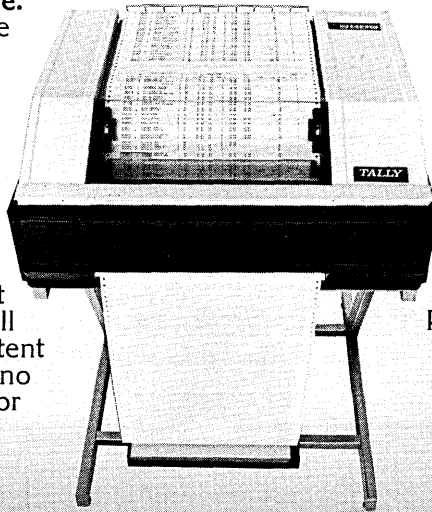

The Tally technique minimizes moving parts. The one-piece Tally print comb prints one horizontal dot row at a time. The paper advance assembly progressively steps the paper vertically one dot row to complete the matrix character. It's simple. It's reliable.

Join Tally's growing list of customers. Write for our brochure. Tally Corporation, 8301 S. 180th St., Kent, Washington 98031. Phone (206) 251-5643.

TALLY®

The line printer for the long run

CIRCLE 56 ON READER CARD

TOTAL INVOICE IN38259									
00728	AR	TAD05	IN38260	11/08/74	14492-1	58	1,500.00		1103
01190	AC	1 MODEL 8P30-24V				4	375.00		1103
00729								2-11201	1,500.00
00742								2-11410	276.00
00743								2-11411	484.00
00746								2-11600	592.00
00747								2-11601	108.00
00740								M/QT=603300004	58 2-46000
00741								M/QT=603300004	58 2-46008
00744								M/QT=603300004	2-56001
00745								M/QT=603300004	2-56002
00748								M/QT=603300004	2-56003
00749								M/QT=603300004	2-56004
TOTAL INVOICE IN38260									
024E TALLY CORP SALES PROOF LIST AND EDIT REPORT DATE 11/15/74 PAGE 10									
00750	AR	TAD05	IN38261	11/08/74	14139	58	750.00		1103
01191	AC	1 MODEL 8P30-48V PERFDATOR				2	375.00		1103
00751								2-11201	750.00
00754								2-11410	114.00
00755								2-11411	252.00
00758								2-11600	246.00
00759								2-11601	54.00
00752								M/QT=603300002	58 2-46000
00753								M/QT=603300002	58 2-46008
00756								M/QT=603300002	2-56001
00757								M/QT=603300002	2-56002
00760								M/QT=603300002	2-56003
00761								M/QT=603300002	2-56004
TOTAL INVOICE IN38261									
00762	AR	NO399	IN38262	11/08/74	14623	3	834.00		1103
01194	AC	1 DRIVE ELECTRONICS				1	294.00		1103
01193	AC	1 E O T OPTION				1	40.00		1103
01192	AC	1 MODEL 8P30-48V				1	500.00		1103
00762								2-11201	834.00
00769								2-11410	78.00
00770								2-11411	181.00
00774								2-11600	167.00
00775								2-11601	39.00
00766	ELSN=PLS	COR=1500	INVTOT=000083400					2-21401	125.10
00765								M/QT=103300001	03 2-40000
00779								M/QT=103400001	03 2-40000
00771								M/QT=103300001	2-50001
00772								M/QT=103400001	2-50001
00773								M/QT=103300001	2-50002
00776								M/QT=103400001	2-50002
00777								M/QT=102390001	2-50003
00778								M/QT=102400001	2-50003
00779								M/QT=103400001	2-80004
00780								M/QT=103400001	2-80004

We asked Control Data

to furnish
"worry-free"
EDP supplies.*



They did it.



CDC WORRY-FREE DISK PACKS AND CARTRIDGES. INDUSTRY COMPATIBLE

Control Data supplies disk packs and cartridges tested to tighter specs than industry standards . . . to help you prevent data loss.

And supports each pack and cartridge with a lifetime warranty.

PACK TYPE:		DRIVE TYPE:		CHARACTERISTICS:		
CDC MODEL #:	IBM MODEL #:	IBM DRIVE:	CDC DRIVE:	TPI:	BPI:	8-bit Byte capacity:
846	2315	2310	—	100	1100	1.25
846-2	—	—	—	100/200	2200	2.5/5.0
847	5440	5444	9425	100	2200	2.5
848	—	—	9427	200	2200	5.0
849	1316	2311	23111	100	1100	7.25
851	—	—	854			
869	2316	2314	23141	100	2200	29.2
871	—	—	841			
873	—	—	23142	200	2200	60.0
876 storage module	—	—	9760	200	6060	40.0
877	—	—	9762	400	6060	80.0
879	3336	3330	33301	200	4040	100.0
881	—	—	844			
882	3336-11	3330-11	33302	400	4040	200.0
883	—	—	844-41			
889	3348-35	3340	9778	300	5500	35.0
892	3348-70					70.0

CUSTOMER ENGINEERING PACKS

Available for all disk pack models for precise alignment, adjustment and maintenance. Compatible with IBM customer engineering packs when appropriate.

NEW! DATA MODULES FOR IBM 3340 DRIVES!

Control Data now supplies compatible 35 and 70 M Byte data modules utilizing their total technology: heads, disks and drives.

FLEXIBLE DISKS

CDC's experience in making flexible disk drives helps in making better flexible disks. Available hard or soft-sectored for CDC 9400, IBM 3740 and other systems, in convenient storage boxes that hold ten indexed disks and adhesive-backed color-coded labels.

HALF-INCH MAGNETIC TAPE

One premium grade is offered. Useable up to 6250 cpi. The tape is extensively tested on Control Data certifying equipment to assure that each reel meets or exceeds ANSI specifications.

PRECISION-PRINTED BUSINESS FORMS

Precision printing and registration on continuous forms can make the difference between fast through-put and frequent interruptions to re-align the printer. You get this precision printing and registration in CDC custom continuous forms, stock tabulating forms, custom snap-out forms, OCR scanning forms, and specialized forms.

PRINTER RIBBONS

Control Data stocks broad selections of ink strengths and formulas, and ribbon sizes, in both fabric and film. CDC Quality Control maintains consistency from first print-out to last . . . gives you more pages of clear print-out per dollar before the ribbon needs to be changed.

*See why **TWA** and many other companies select from Control Data's broad line of "worry-free" EDP supplies. Call collect (612) 853-7600. Or, mail the coupon today.

Do it.

Mr. H. L. Peterson, Business Products
Control Data Corporation, Dept. D-115
P.O. Box 1980 Airport Station, Minneapolis, MN 55111

Tell me more about: Your Disk Packs for my _____ computer. Data Modules
 Flexible Disks Customer Engineering Packs Magnetic Tapes
 Business Forms Printer Ribbons

Name _____ Title _____

Company _____ Address _____

City _____

State _____ Zip _____ Phone _____



hardware

Off-line

Perhaps to underscore the lack of handholding offered with its new 5100 "consumer computer," IBM's General Systems Division has been answering inquiries about the machine's performance with a terse "we have neither the time nor the resources to answer all possible questions about the product" when we asked for a representative add time. This could be a boon to watch manufacturers, however, as IBM is suggesting that prospective users have a stopwatch at the ready when the machine is demonstrated to them. That's what Hewlett-Packard's Calculator Division in Loveland, Colorado did to compare the 5100's performance to H-P's 9830. The 5100 is described elsewhere in this issue.

The January issue will feature a crt terminal survey. If your firm manufactures crt terminals for either the oem or end user market, or is planning to in the near future, please send for a questionnaire to Datamation, 1801 S. La Cienega Blvd., Los Angeles, Calif. 90035. Attn: Crt Survey

OCR-B, an alternative character set for optical character recognition systems, has been revised and approved as a national standard by the American National Standards Institute. OCR-B, which was created to give users a choice of readability between machines and people, is more conventional in appearance than OCR-A to make it easier for employees to work with OCR documents and records.

Manufacturers interested in obtaining a copy of the 60-page standard (OCR-B), X3.49-1975, should contact ANSI through the sales department at 1430 Broadway, New York, N.Y. 10018. Copies are \$9.75.

The Firestone Tire and Rubber Company is using a Sanders 900/-2250 graphic emulation system to design tire treads in a fraction of the time required by manual methods. Among the system's capabilities are simulation of contact patch patterns under various amounts of inflation, cross section examination, and running noise levels. Satisfactory patterns are transmitted to a plotter for hard copy from which a template or mold can be designed.

Programmable Handheld Calculator

Texas Instruments must be making purchasers of Hewlett-Packard's impressive line of handheld calculators wonder whether it was wise to be the first kid on the block with such a device. The latest equivalent is for H-P's top-of-the-line model 65, and it's called the SR-52. At \$395, the price of the original HP-35 nonprogrammable electronic slide rule, the SR-52 is impressive at roughly half the price of the HP-65. Prerecorded programs are stored on "gum sticks," magnetic cards measur-

ing 2 $\frac{7}{8}$ by $\frac{5}{8}$ -inches, and like the 65, the 52 can learn original programs written by the user. Entry for the machine is in true algebraic fashion—an alternative to H-P's Reverse Polish Notation (RPN) usage. Up to 224 program steps can be stored on each gum stick. Twenty independent addressable memory registers permit addition, subtraction, multiplication, and division of any displayed quantity with any memory register without affecting the keyboard calculation in progress. There are 23 preprogrammed key



product spotlight

Medium Scale System

In contrast to most other manufacturers, Univac prefers to play down any technological changes occurring in its systems, not wishing to scare current users and potential users away. It could probably never get away with a total redefinition of its 36-bit word architecture anyway, so it's just as well. (It was no cake walk for IBM to switch from 36-bits to bytes 11 years ago, for that matter.)

But the Univac line is always changing. The latest example is the 1100/10, the smallest of the 1110, 1108, 1106 siblings announced so far. It's a comfortable machine to be around—it's like being around an IBM 7090 upgraded with the latest available technology. The 1100/10 is based on 4K bit-per-chip MOS memory circuitry and will do battle with IBM's 370/125 and 370/135 systems (more likely with replacements for these, called 128s and 138s), and small models in Burroughs 6700 series, and Honeywell's 66 series machines. The 1100/10 seems to be an

adequate competitor: multiprocessing, multiprogramming, direct upgrade capability, a plethora of languages that includes ALGOL, JOVIAL, PL/1, FORTRAN, and COBOL; syntax pre-scanning compilers, etc., should interest potential users. Univac estimates that the 1100/10 more than triples the number of potential customers for its systems.

Additional features for the 1100/10 include a complete complement of peripherals, communications gear, 128 user registers, and a comprehensive line of software support products. System prices with the minimum 128K of memory start at about \$20K/month, and can range as high as \$55K/month, or \$800K and \$2 million, respectively. The small versions of the system undoubtedly outperform the old IBM 7090/7094 at perhaps one-fifth the price. The 1100/10 will undoubtedly do well against its competitors' latest machines, too. SPERRY UNIVAC, Blue Bell, Pa.

FOR DATA CIRCLE 220 ON READER CARD

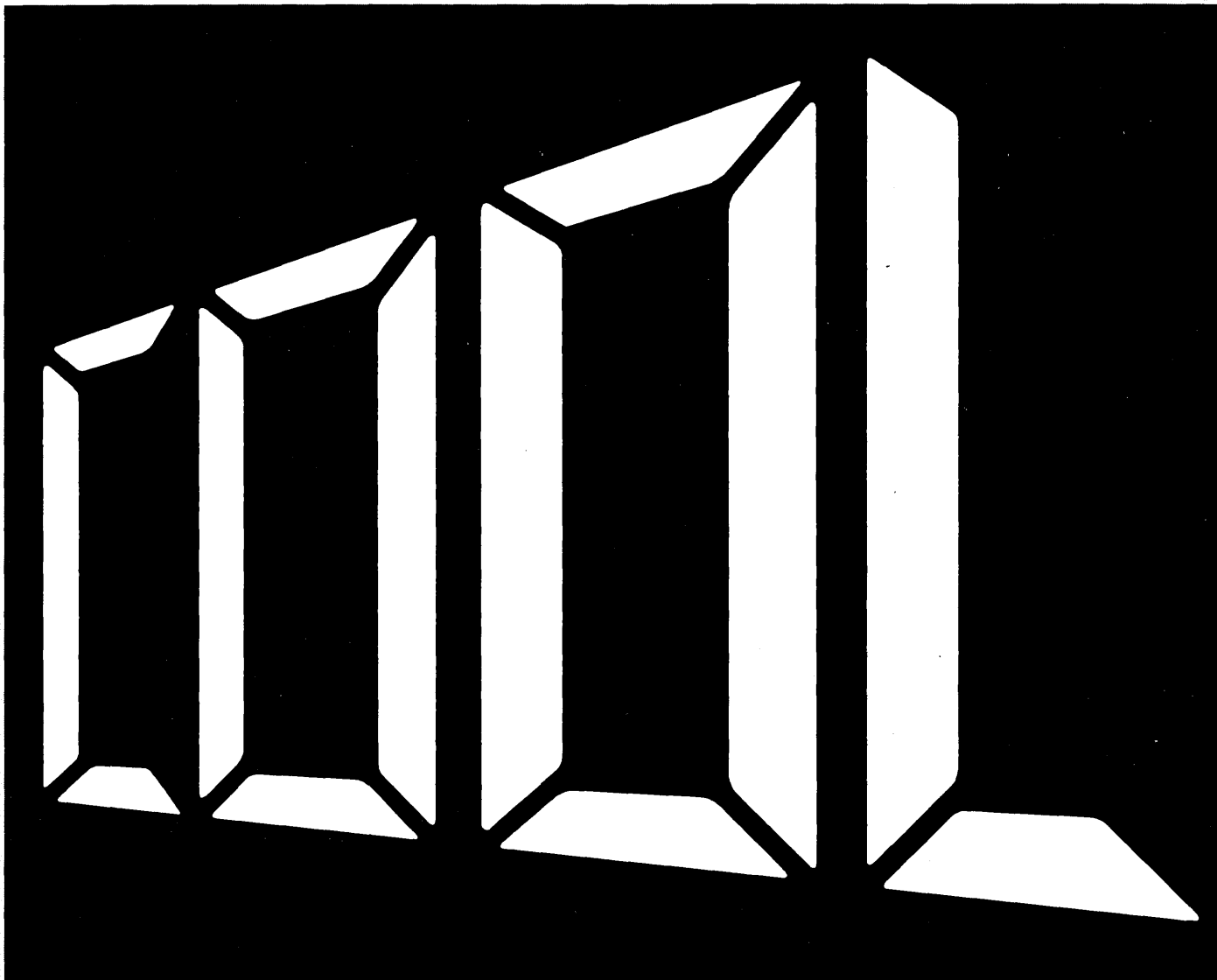

An advanced computer room air conditioning system that tells you exactly how it's feeling.

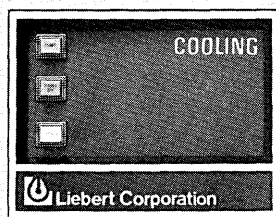

Introducing Deluxe System/2 with Precision Control Readout (PCR-2). It tells you at a glance whether all systems are functioning properly. Or that specific attention is needed to keep your computer room air conditioning system at peak

efficiency. And, while PCR-2 tells it all—precisely. The rest of the Deluxe System/2 does it all—precisely.

With these features:

Economical, quiet semi-hermetic compressors. Low maintenance. Low operating speed. Long life. Low failure rate. Infra-red humidification system adds clean pure water vapor to a precise level. Instantaneous response to system demands. Exclusive large face area A-frame cooling coil for highest cooling efficiency.

And these new features:

Exclusive three-stage reheat for precise control. By-pass air flow design increases humidity control precision. Compressor alternator switch to ensure even compressor use—longer compressor life. *Auto-flush system to clean the humidification reservoir, eliminates scale before it starts. *Solid state Mode-Alert System to warn of high compressor head pressure and other malfunctions. Before they happen. *Solid state winter start kit. Automatic operation down to -20°F outside. Dual fan speed control, too.

These are just a few of the reasons why you should select Liebert. For more information call us on our special Wats line. Dial toll free: 800/848-6884. In Ohio, call collect: 614/888-0246.

*Recommended options

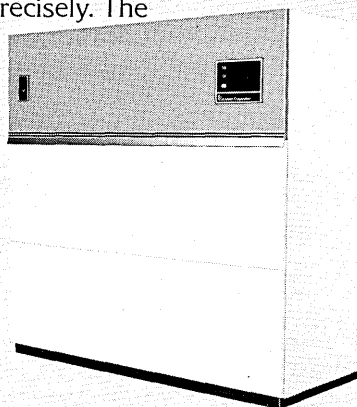

SELECT LIEBERT. SELECT QUALITY.
Liebert Corporation
 1050 Dearborn Drive, Columbus, Ohio 43229
 CIRCLE 89 ON READER CARD

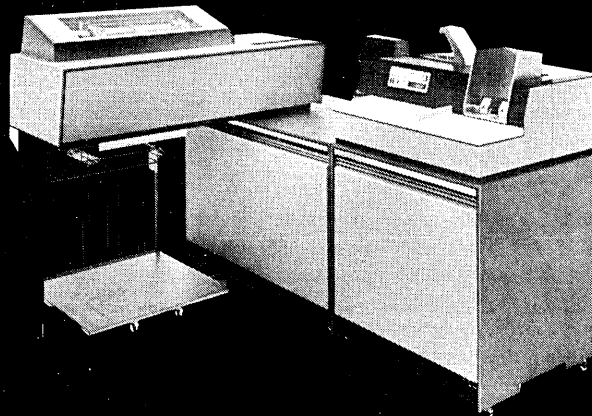

THIS IS A REMOTE BATCH TERMINAL.

About all it can do is shuffle cards and do a little printing.

MODCOMP SALES OFFICES: ALBUQUERQUE, NM/ATLANTA, GA/BOSTON, MA/CHICAGO, IL/CINCINNATI, OH/DALLAS, TX/DENVER, CO/DETROIT, MI/HOUSTON, TX/
HUNTSVILLE, AL/INDIANAPOLIS, IN/KANSAS CITY, KS/LOS ANGELES, CA/MINNEAPOLIS, MN/MONTREAL, CN/NEW YORK, NY/ORLANDO, FL/
PHILADELPHIA, PA/ROCHESTER, NY/SAN JOSE, CA/SEATTLE, WA/TORONTO, CN/WASHINGTON, DC
INTERNATIONAL OFFICES OR REPRESENTATIVES IN ENGLAND/France/BELGIUM/WEST GERMANY/NORWAY/SWEDEN/JAPAN



THIS IS MODCOMP'S REMOTE TERMINAL SYSTEM.

So much more. For so little more. The MODCOMP 3-in-1 Remote Terminal System.

It's an intelligent Remote Batch Terminal. It's a satellite computer. It's a stand-alone processor. All in one.

With it, remote offices or plants can handle a lot of their local computing. Locally. Without heavy charges for long distance dial-up lines to the central processor. And without ever sitting around drumming their fingers waiting for an answer.

MODCOMP RTS comes in three versions. So you can pick the one you need. Depending on what you need. All three systems will communicate with your IBM, Control Data or Univac central computer. Because with all three we throw in emulator software for IBM 2780/3780 and CDC 200UT terminals. Univac 1004 terminal and HASP work station emulators are also available.

One of these standard RTS packages will probably fit your needs just the way it is, right now. But the beauty of them all is that they can be added on to or changed at any time, to suit your own changing needs (add-on options include mag tape and other alternative peripherals).

And one thing you can be sure of. When you buy a MODCOMP Remote Terminal System, it's going to cost you a lot less than trying to get anywhere near the same performance anywhere else.

MODCOMP RTS-1 As an intelligent RJE terminal, it is used to enter, transmit and receive data between the remote location and your central processor. When it's not doing that, its MODCOMP II computer with 64K bytes of core memory and dual floppy disc can take on a number of local computing tasks.

MODCOMP RTS-2 (illustrated) The next step up, it can handle both remote batch and local processing simultaneously. And its moving head disc unit gives you a lot more storage capacity and computing speed.

MODCOMP RTS-3 The block buster. With 128K bytes of memory, floating point hardware, plus a dual disc unit with 5-million bytes of storage. Running both remote and local processing concurrently, it can handle just about anything you throw its way.

For more information about Remote Terminal Systems, call your nearest MODCOMP sales office. Or write Modular Computer Systems, 1650 West McNab Road, Ft. Lauderdale, FL 33309. Phone (305) 974-1380

European Headquarters: 103 Mytchett Road Mytchett, Surrey, England. Phone (0252) 514251

MODCOMP 
THE INTELLIGENT WAY TO GO.

hardware

functions that include trigonometry and logs, powers and roots, factorials,



reciprocals, three conversions, and pi can be directly executed from the keyboard. Other features include 10 decision instructions, five user-set flags (handy to use for branching to program segments automatically), 10 user defined keys, and 72 user defined labels. There's a one-year warranty offered on the SR-52. A starter set of programs, including diagnostics, comes with the machine. TEXAS INSTRUMENTS INC., Dallas, Texas

FOR DATA CIRCLE 221 ON READER CARD

OCR Page Reader

The model 101 ocr page reader seems to be a clear breakthrough in the technology usually used in these devices. Instead of a back-and-forth raster scan, the 101 uses a continuously rotating optical system that can read a typed line at the rate of 10,000 cps. That much speed isn't required however, so the 101 has a chance to examine every character three times before the next line comes into view. The result of this approach is said to be an error rate better than one character in 25,000, plus the ability to read a densely typed 8½ x 11-inch page in approximately 10 seconds. The 101 uses a special Selectric golf ball element with bar codes under the associated letters.

For now the 101 is a strictly oem item, but it's thought that an end user price of approximately \$12,500 is feasible, which should certainly draw some systems houses' attention. TAPLIN BUSINESS MACHINES, INC., Burlington, Mass.

FOR DATA CIRCLE 222 ON READER CARD

Uninterruptible Power

Uninterruptible power supplies are usually so expensive that they can only be justified by medium and large scale users. Not so with this manufacturer's unit, which is expressly designed for the minicomputer market. The unit can supply 115 or 230 VAC to a 1000

watt load for either 15 or 30 minutes, and prices drop down below \$2K. SYNERGETIC SCIENTIFIC SYSTEMS, Gainesville, Fla.

FOR DATA CIRCLE 225 ON READER CARD

Graphics Terminal

Graphics equipment prices are suddenly plummeting. Last month Tektronix introduced a very low cost system, this month it's DEC's turn. The attractive looking VT55 is priced at only \$2,495 and is intended for use in science, business and education for such tasks as plotting histograms, waveform and peak analyses, data display, monitoring and trending. The terminal is also bound to find application in network oriented data base systems. Interactive graphics with up to 1K data points is provided, with 512 x 256 resolution. Graphic cursors can be used for marking portions of a graph. Horizontal and vertical lines can be displayed for constructing background grids. Including the ANSI standard keyboard, the

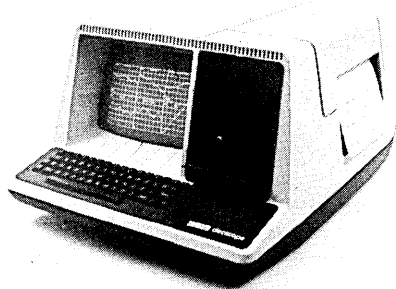

terminal can provide 24 lines of 80 alphanumeric characters in addition to straight graphics capabilities. Communications rates go up to 9,600 baud. A built-in, optional hard copy unit is priced at \$800 and copies both text and graphic screen contents on electrolytic paper in 25 seconds, either by depression of the "automatic print" key or under control of the host computer. Deliveries begin this month. DIGITAL EQUIPMENT CORP., Maynard, Mass.

FOR DATA CIRCLE 223 ON READER CARD

Distributed Processing

Raytheon has apparently decided it was so deep into distributed processing anyway, through its considerable business with the airlines, that it might as well make the investment and fully outfit the equipment for commercial offerings. The PTS/1200 is the result. A Raytheon 700 series 16-bit mini is used together with Diablo discs, Centronics or Data Products Printers, and the manufacturers' crt terminals. Raytheon claims to be the world's largest manufacturer of intelligent terminals, producing more than 1,000 per month. The PTS/1200 has been in field test for

10 months (22 systems), and among its users are Bell Canada (handling residential telephone orders), General Motors, Union Carbide, and Benjamin Moore Paints. Initial users have

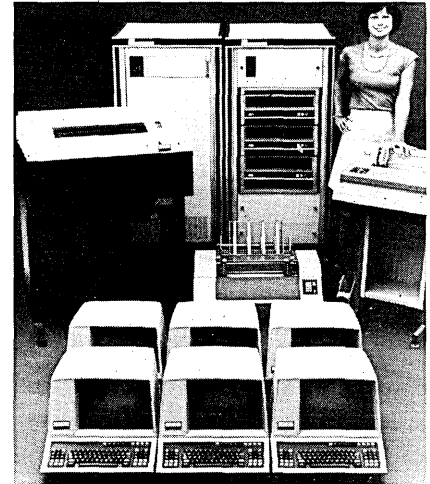

seemed happy enough to convert from Beta test status to lease or purchase.

Software is a home-grown macro language, MACROL, utilities, and a query/response package. The operating system multi-tasks (except when emulating 3270s), so if you have four terminals, you can run four jobs. The normal system comes with 64K of memory and can go to 128K if needed. The DOS operating system takes up 20-25K. Prices seem reasonable: a 64K system, four terminals, five megabyte disc, and 300 lpm printer rents for \$1,200/month (including maintenance) on a three year lease. The purchase price for the system is \$35K. RAYTHEON DATA SYSTEMS, Norwood, Mass.

FOR DATA CIRCLE 224 ON READER CARD

Oem Crt

This small new manufacturer is gearing up to introduce a low cost crt terminal to the oem market. Called the MAS/T1, the unit is basically designed for the tty replacement market—a nonintelligent terminal if there ever was one. A 9-inch video display is used for displaying 12 lines of 80 5x7 dot matrix characters (24 x 80, and 12-inch monitor are options.) Standard features include cursor control, character and line insertion/deletion, tab control, selectable speeds to 9600 baud, and solid/blinking underline cursor. RS-232 hookup is also standard. Other I/O devices, such as cassettes, floppy disc, or printer can be added on request. The unit price is \$649, dropping to \$499 in orders of 100. The new firm will probably not be able to handle very large orders for some time, and standard delivery is at least two months. KKM CORP., Grand Forks, N.D.

FOR DATA CIRCLE 228 ON READER CARD

Diskette Reinforcement

Is your installation using floppy discs so much that the centerhole is wearing out? If so, this manufacturer probably has a solution. It's called Diskette Hardhole, and for \$9.95 you get your choice of either 20 Hardholes and a precision locating tool, or 50 Diskette Hardholes. Inserted into the media in a few moments, problems with centerhole wear problems are a thing of the past, it's claimed. STODDARD ENGINEERING, Westlake Village, Calif.

FOR DATA CIRCLE 227 ON READER CARD

Talking Calculator

Is the world ready for a calculator that talks? This firm is going to find out with its ARC 9500. Actually the device could find good acceptance in training the blind, but applications for sighted persons are also possible. No longer would a user have to continually look back and forth from a long column of figures to verify that they had been entered properly if the device could read them back to him. This particular model is an eight-digit unit with display. It announces each key entry and the results of every calculation. The price of \$565 may seem high, but if the

EQUALS NINE FOUR TWO
THREE SIX POINT
FIVE EIGHT

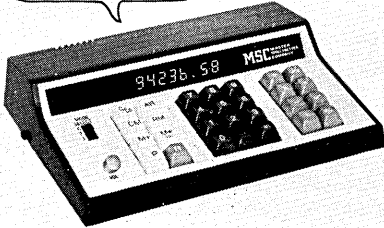

unit sells, prices will undoubtedly come down, and many of us might have programmable units like this in the next few years. MASTER SPECIALTIES CO., Costa Mesa, Calif.

FOR DATA CIRCLE 226 ON READER CARD

Programmable Controller

The pcc 50/40 is a programmable communications controller that houses a microcomputer to qualify it for use as a remote data concentrator, polling controller, device selector, time-division multiplexor, etc. The basic unit is available in four different tabletop enclosures providing from 4-33 card slots for line interfaces or memory expansion. The central control module contains all system elements necessary for an operational system including 8K bytes of memory, real-time clock, auto restart timer, I/O ports, and the micro-processor. Memory can go up to 64K bytes in capacity. Asynchronous communication line interfaces are

November, 1975

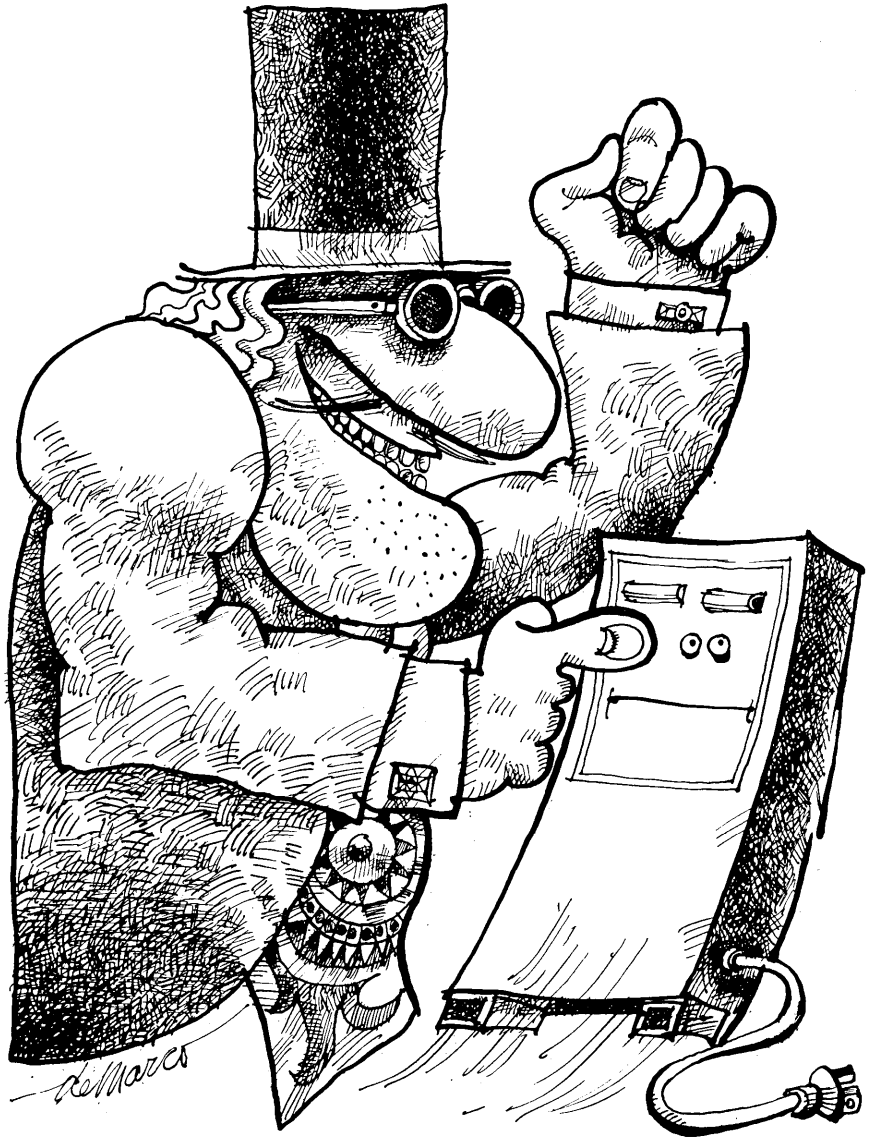

Buy protection. Or else.

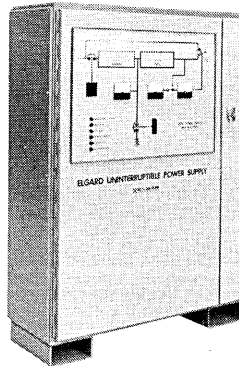

Or else when the power fails, your computer can lose its mind, its memory ... and your data. But an Elgard Uninterruptible Power System can give your computer all the protection it needs—up to several hours of back-up time, plus continuous isolation from line spikes and transients. Elgard models are available in 0.5KVA through 40KVA capacities.

You'd better buy protection. Get in touch with us for complete information. Before your computer is rubbed out. Elgar Corporation,



ELGAR

Elgar also is a leading producer of AC Line Conditioners and AC Power Sources.

8225 Mercury Ct.,
San Diego,
California 92111,
Phone (714)
565-1155.

CIRCLE 87 ON READER CARD

hardware

available with controls for use in many applications, including auto answer. Interfaces include both RS-232 and CCITT V.24 synchronous, with speeds up to 19.2 kilobaud, and asynchronous rates up to 9,600 baud. The basic 50/40 is priced at \$2K. Communication line interfaces are approximately \$250 each. MICOM SYSTEMS, INC., Chatsworth, Calif.

FOR DATA CIRCLE 230 ON READER CARD

Micros to Minis

General Automation is still primarily an oem-oriented company, only really interested in large orders, and willing to work with large end users and oem's who can help themselves along toward systems solutions. With that in mind, the company has announced a new compatible line of oem systems (also compatible with its SPC-16 minicomputer—a definite plus) that place it squarely in competition with DEC and Computer Automation. Things could get very lively in the low end of the marketplace known as ironmongers.

The lineup: four chunks of hardware, the GA-16/110, /220, /330, and /440. The 110 is a single board n-

channel MOS, two-chip processor. The 220 is almost the same but comes on two boards and adds such features as micro console, tty port, direct memory access port, and is designed to be buried into other systems. Both the /110 and /220 come with auxiliary power to protect semiconductor memory contents in the event of power failure.

The /330 is for the designer who wants only a board (4, 8, or 16K memory) and will add the rest. Therefore there's no provision for amenities such as a console, etc. Options include memory stack and memory parity. The /440 comes with goodies like memory stack, memory protection, up to 1 megabyte of core, memory parity detection, non-inhabitable interrupts, mapping for addressing beyond 64K, etc. Four system levels include disc batch, core resident real-time, real-time foreground and background, and real-time multiprogramming, memory management. Oem pricing looks like approximately \$531 for /110s with 1K of memory, \$765 for /220s (1K), \$1,950 for 4K 330s, \$5,370 for 16K 440s on maximum discount. Having been burned with its Silicon-on-Sapphire (SOS) offering, GA is playing it wise: first models of 440s have been in the field for several months, 330s and

220s are due in January, and the 110 will be out in December. GENERAL AUTOMATION, INC., Anaheim, Calif.

FOR DATA CIRCLE 231 ON READER CARD

PDP-11/45 Memory

Savings of approximately 60% over previously available semiconductor memories are now possible by using a new 4K bipolar board in DEC's PDP-11/45 and PDP-11/50 computers. Called the MS11-AP, up to 32K words can now be installed internally, compared to the previous maximum of 8K. The bipolar storage permits computer operation at speeds up to 3 million instructions per second, roughly three times as fast as core and 40% faster than MOS. Priced at \$19K in 16K-word unit, shipments are underway. DIGITAL EQUIPMENT CORP., Maynard, Mass.

FOR DATA CIRCLE 232 ON READER CARD

SDLC Interfacing

The Quad Synchronous Adapter is intended to simplify interfacing of four synchronous communications lines between Interdata's 16-bit and 32-bit computers and the coming data communications disciplines. The QSA supports the hardware features of IBM's Synchronous Data Link Control (SDLC), High Level Data Link Control

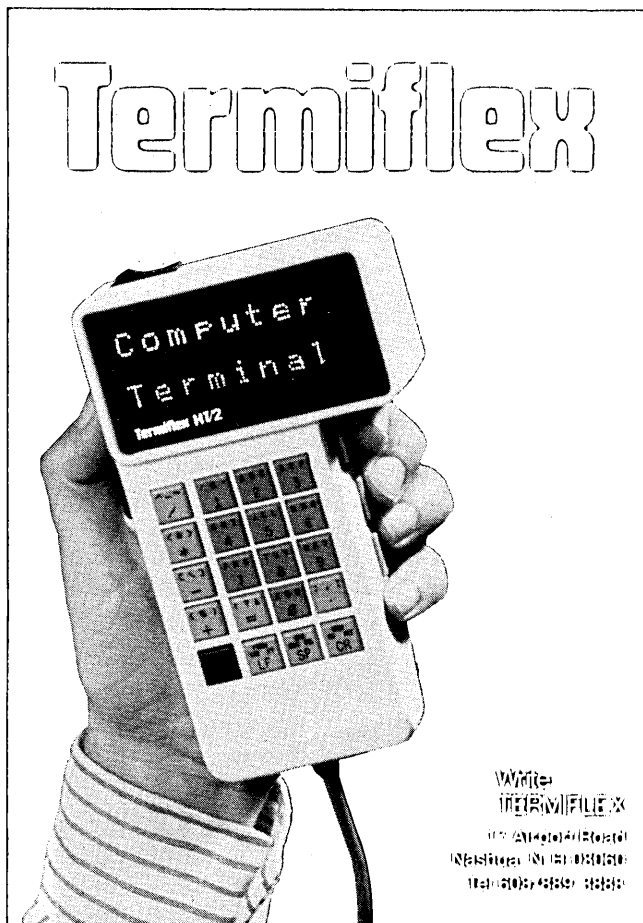

Termiflex

Write
TERMIFILE X

117 214-6014/1212-61
Res: 117 214-6012-61
Tel: 214-6012-6121

CIRCLE 107 ON READER CARD



NEW MASTER OUTPUT TAPE

or Secondary Standard Amplitude Reference Tape is a selected tape matching the NBS with a tolerance of $\pm 2\%$.

- Guaranteed Compatibility
- Reliability
- Selected High Quality Tape
- Low Prices & Quantity Discounts
- Prompt Delivery

NEW TAPE CRIMPER

Hand cuts and forms end of 1/2" Mylar Computer Tape.

Enables positive loading of Auto threading Transports.

Tape is cut to 9/16" dia. and simultaneously forms 3 ribs 1/2" long, 1/16" high stiffens tape end.

PERICOMP CORPORATION
14 HURON DRIVE, NATICK, MASSACHUSETTS 01760 U.S.A.
(617) 237-4052

Distributor inquiries outside U.S.A. invited.

CIRCLE 97 ON READER CARD

Look at scanning. Key/disk. Look at performance.
And costs. Look at multimedia.

When you look at the best... you'll see the Cummins KeyScan™ Data Entry System.

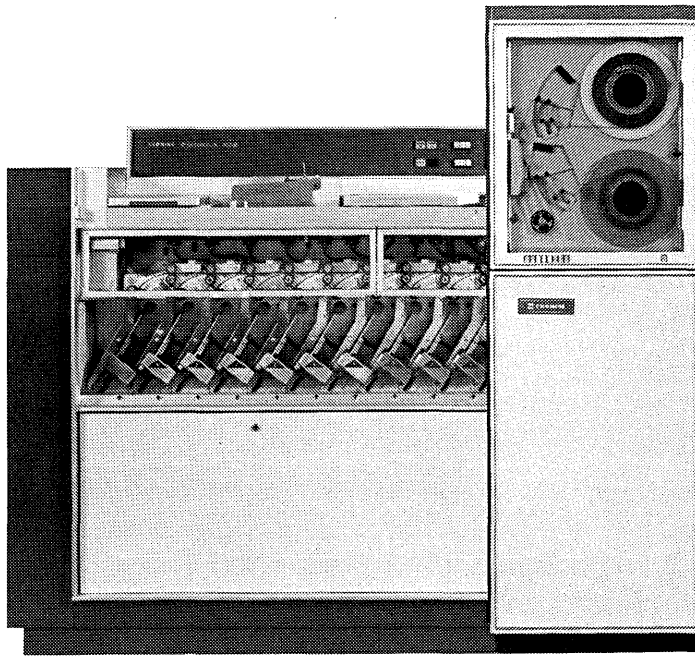

Look at scanning. With KeyScan, a single key stroke of each unrecognized character provides re-entry of rejects without rehandling while still scanning the same block of documents. Data from all documents is edited and balanced by batch, in a single pass through the System.

Look at key entry. Cummins key/disk terminals provide more power per dollar than any other key entry system.

Look at both. KeyScan is a shared processor, key/disk scanning system that affords unparalleled flexibility. It's the first multimedia data entry system, the only high performance system *and* it's moderately priced.

Whether you need an OCR scanning system, a stand-alone key/disk system, or an off-line print station . . . KeyScan enables you to select what you need at a price you can afford.

And, as your requirements change, you can reconfigure your hardware and software to do the new job . . . the best way.

All this from a company with systems, programming, and forms design support, and over 45 branch sales and service offices located across the country. So write today for our new 4400 KeyScan System brochure. Write: Cummins, 836 Waukegan Rd., Glenview, IL 60025. Or better yet, call us at 312/724-8000 and make an appointment to visit our demonstration facilities.

And remember, when you think data entry, look at Cummins KeyScan Multimedia Data Entry System. Then look at other systems and you decide which is best.

4400

KeyScan Multimedia Data Entry System

29-1371

November, 1975

CIRCLE 18 ON READER CARD

CA CUMMINS
CUMMINS-ALLISON CORP.

159

1975 Computer Salary Survey—Yours Free!

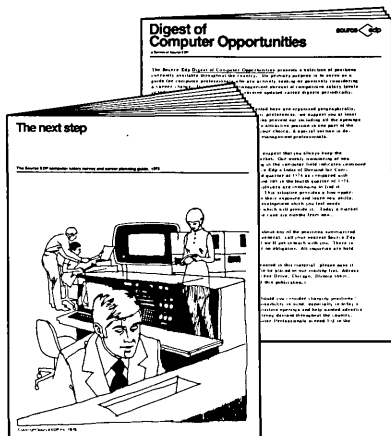

Do you know how much money your colleagues make for doing the work you do? Do you know which computing skills are most lucrative? Do you know how to get a better position?

Source Edp does. And we'll share what we know with you. Our ninth annual salary survey and career planning guide, "The Next Step," compiles salary data received from over 15,000 computer professionals. We add to that advice developed over our thirteen years of computer recruiting experience: danger signals that mean you should start looking for a new position, mistakes to avoid, strategy in career planning. You'll also receive the "Digest of Computer Opportunities," our periodic supplement listing positions available right now in every part of the country.

Source Edp is the largest nationwide recruiting firm devoted exclusively to computer professionals. We offer "The Next Step" as a service to people like you. Fill out the reader reply card and we'll send you one absolutely free. Or write:

Source Edp
Corporate Headquarters
100 South Wacker Drive
Chicago, Illinois 60606
312/782-0857

source  edp

REGIONAL OFFICES:

ATLANTA	404/634-5127
CHICAGO	312/782-0857
CLEVELAND	216/771-2070
DALLAS	214/638-4080
DETROIT	313/352-6520
HOUSTON	713/626-8705
IRVINE, CA	714/833-1730
KANSAS CITY	816/474-3393
LOS ANGELES	213/386-5500
MINNEAPOLIS	612/544-3600
NEW YORK	212/682-1160
NEW ORLEANS	504/523-2576
NORTHFIELD, IL	312/446-8395
OAK BROOK, IL	312/323-8980
PALO ALTO	415/328-7155
PHILADELPHIA	215/665-1717
SAN FRANCISCO	415/434-2410
ST. LOUIS	314/862-3800
UNION, NJ	201/687-8700

CIRCLE 122 ON READER CARD

hardware

(HDLC), and Advanced Data Communications Control Procedure (ADCCP) protocols. One version, priced at \$1,600, communicates with traditional Bisynch lines and can be upgraded easily to talk Bisynch as well as the three new protocols. The capability is offered as a hardware option for the manufacturer's mini line. Features of the QSA include complete modem control capabilities and the ability to modify various character parameters under program control. Full-duplex or half-duplex operation is provided. The QSA can generate throughput rates up to 1.6 megabaud. INTERDATA CORP., Oceanport, N.J.

FOR DATA CIRCLE 235 ON READER CARD

Data Transmission

A device like the series 500 transceiver could solve a lot of intracompany communications problems. The device sends data from 1.5 to 50 megabit per second rates across coaxial cable at distances up to 500 feet. Six models are available at various data rates. A conventional serial data interface allows attachment of a broad range of equipment, from host computers to storage devices. Purchase prices for the Series 500 transceiver start at \$5K. NETWORK SYSTEMS CORP., St. Paul, Minn.

FOR DATA CIRCLE 229 ON READER CARD

Midicomputer

There's a new upper end to this manufacturer's SLASH series of midicomputers, the SLASH 7. It's a 24-bit machine that will compete with Interdata's 8/32, the MODCOMP IV, SEL 55, Eclipse S-300 and PDP-11/70, where

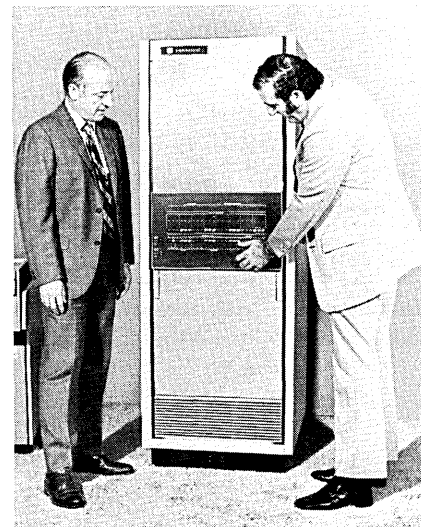

the flexibility of the longer word length (in most cases) should be an advantage. The /7 has some nice features. Its asynchronous cpu has instruction pre-

fetch and interleaved core memory to provide an effective cycle time of 425 nsec. There are four operating systems, all field proven: a resident monitor (ROS), a tape operating system (TOS), a disc operating system (DOS), and a disc monitor (DMS). This last system currently handles simulation and scientific computation both for Harris and its customers. Languages include FORTRAN IV, COBOL, Interactive BASIC, SNOBOL 4, RPG II, and a macro assembler. Basic systems with 32K of memory start around \$45K. HARRIS COMPUTER SYSTEMS, Fort Lauderdale, Fla. FOR DATA CIRCLE 234 ON READER CARD

System/3 Memory

It's never too early to begin Christmas shopping, so why not take advantage of this manufacturer's offer: a 24K byte increment of additional storage for the IBM System/3 for \$200/month. That's cheaper than paying the dp manager overtime to shove jobs through a memory constrained system. What the company would really like, however, is that you get a combination of its memory and high-speed printer offer-



ings which, it claims, is a more attractive system than the recently announced model 12. Example: a 64K Model 10 with 600 lpm printer (\$1,813) versus a model 12's \$2,756. These are rental prices; better terms are available with longer-term leases. Other memory configurations are available from 8-56K bytes. DECISION DATA CORP., Horsham, Pa.

FOR DATA CIRCLE 236 ON READER CARD

Graphics Terminal

Some really interesting combinations of low-cost peripherals wedded to microprocessors have been announced recently (IBM's 5100 desktop computer, for one), and here's another one. It's a graphics terminal complete with a firmware implementation of BASIC, 8-32K of memory, a 3M data cartridge to provide up to 300 kilobytes of off-line storage, and an 11-inch screen. This allows, for example, an engineer to turn mathematical formulas into high resolution, three

WE MAKE THESE ELECTROSTATIC PRINTER/PLOTTERS EASIER TO READ.

Test it yourself with a free sample roll.

Graphic Controls electrostatic paper reads easier than conventional types. Because it's obviously whiter...giving a sharper, blacker look to letters, numbers, dots and lines.

We should be able to produce a better paper. Making specialty papers is our ONLY business. We produce both report and translucent grades that fit all **Gould, Varian and Versatec** electrostatic printer/plotters in both roll and fanfold form.

In the wider roll sizes we offer the unique feature of rolls

cross-perforated every 11 inches for easy fanfold stacking.

As a standard feature, we sequentially page number all of our fanfold packs for increased operating efficiency and ease of information retrieval. For your specialized applications, roll and fanfold paper is available with preprinted formats in your choice of color.

All this and...priced significantly below your present supplier.

For more information—or a free sample to make your own reading test—use the coupon. Or call Ray Newstead, Manager of Marketing. Phone: (716) 853-7500, Ext. 352.



Gould

Versatec

Varian

Send me more information on your electrostatic paper, including prices. Estimated annual usage: _____ rolls.

I'd like a free sample to make my own reading test on my _____ machine. Chart No. _____.

Have your representative call.

Name _____
 Company _____
 Address _____
 City _____ State _____ Zip _____



COATED PRODUCTS DIVISION
GRAPHIC CONTROLS CORPORATION
 189 VAN RENSSELAER STREET, BUFFALO, NEW YORK 14210

hardware

dimensional graphics representations with just a couple of BASIC statements. The effect of design modifications can be made immediately apparent.

The crt screen displays 72 characters across 35 lines, and there are 1024

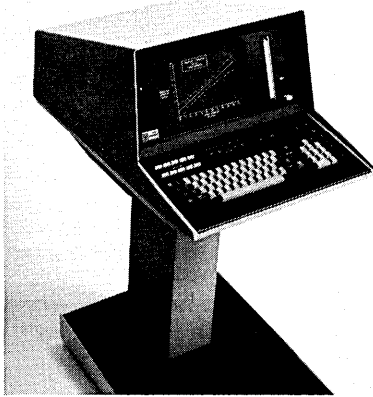

x 780 addressable points for graphics work. Peripherals available include hardcopy units, joystick, and a cartridge tape recorder. Much of the software from previous Tektronix offerings runs stock on the 4051. The price for an 8K system is \$6,995, or \$280/month on a 36-month lease. TEKTRONIX, INC., Beaverton, Ore.

FOR DATA CIRCLE 239 ON READER CARD

Tty Work Station

The Deskware unit can be used to develop a work station around the Teletype Dataspeed 40 series of keyboard displays and printers. Using the unit places the operator closer to the keyboard, which is recessed, providing a broad wing on which to place work materials and a shelf for storing paper, personal belongings, etc. For Dataspeed 40 users without the optional printer there will be a work area on both sides of the keyboard. The tubular steel frame is available in six standard colors and the plastic laminate top in three. It's priced at \$220. MINI-COMPUTER SYSTEMS, INC., Elmsford, N.Y.

FOR DATA CIRCLE 233 ON READER CARD

Peripheral Interface

The 60/70 permits IBM peripherals, such as the new 3850 mass storage system, or the 3330 large scale disc storage peripheral to be used with non-IBM gear. The 60/70 provides an IBM compatible 2760 selector channel, 2770 byte multiplexor channel, and/or a 2780 block multiplexor channel for either a DEC PDP-11 (including the new PDP-11/70) or Varian Data Machines 620f or V70 computers. All IBM 360/370 channel functions are performed with the same numbers of de-

vice controllers and devices. Prices start at \$34K, allow eight weeks for delivery. DATAWEST CORP., Scottsdale, Ariz.

FOR DATA CIRCLE 238 ON READER CARD

370/165 Frequency Converter

Imagine all the things you can do with a frequency converter for the 370/165 and 370/168 models that is quieter than a disc unit (63 dba to be exact). You could put the converter in the same room with the system, thus tightening security measures. You could release the room currently occupied by the IBM unit for some other purpose, such as storage. The converter is IBM approved and measures 71 x 26 x 60 inches. The floor under it must be capable of supporting 3,000 pounds. Pricing starts at \$16,800. CONTROL SYSTEMS, INC., Deer Park, N.Y.

FOR DATA CIRCLE 237 ON READER CARD

✱

A robot bemoaning his role,
Said, "A mechanized man is not whole:
I don't get to dance,
or engage in romance—
I guess it's because I lack soul."

—Gloria Maxson

What makes The Audit Analyzer invaluable to DP people is that they don't have to use it.

This might seem odd, but The Audit Analyzer is designed so that an auditor can, himself, code the requests for the exact analyses and report formats he needs.

He can generate confirmations, stratified and

aging reports, frequency distributions — in fact, most reports he wants by using an easily learned free-form language. So if the auditor has The Audit Analyzer to generate reports he needs, DP people don't have to bother with The Audit Analyzer. . .

Unless, of course, they want to.

Sooner or later, your auditors are going to have a reporting requirement which they don't feel they can handle. You could certainly produce the report they want with COBOL — or, you could use whichever of The Audit Analyzer language levels is appropriate. This complex report can then be catalogued and used by the auditor whenever he needs it.

With the power of The Audit Analyzer's multi-level language system you can perform

calculations conditionally based on some test, build and manipulate arrays of data, or even call your own subroutines to handle special data structures.

It's nice to know The Audit Analyzer is there if you need it. But the less you have to use it, the better you'll like it.

For further information, call or write to Alan Graubard, Program Products Incorporated, 95 Chestnut Ridge Road, Montvale, New Jersey 07645. (201) 391-9800.

CIRCLE 111 ON READER CARD

The Varian System

Your Business is Our Business

When the complex information processing problems of your business demand more than just traditional solutions, then you need the Varian System.

Our business is to provide you with a broad, open-ended selection of computer hardware, firmware and software that gives you speed, performance and flexibility. The Varian System, with an unlimited range of application, allows you to design your own system to meet the specific demands of your business.

VORTEX, one of the world's best real-time operating systems, offers efficient proven software packages including the TOTAL data base management system.

Multi-lingual capability, COBOL, RPG II, BASIC and FORTRAN IV Level G lets you select the language best suited to your application.

VTAM data communications software provides you a macro level facility for handling a wide variety of applications.

HASP/RJE software lets your Varian System communicate with large scale computers.

Micro-programmable 330ns processors give you high performance.

Varian's 190ns WCS, double precision floating point processors and memory map can give you even higher throughput of data during those critical run-times.

A wide range of peripherals and special interfaces, four I/O techniques and dual-port memory access also let you configure your system for maximum I/O throughput.

A network of field service engineers, analysts and full staff of factory experts are committed to serving you with system configurations, hardware and software specials, installation, operator training and systems maintenance.

Whatever your business, contact any of our offices throughout the world, or Varian Data Machines, 2722 Michelson Drive, P.O. Box C-19504a, Irvine, California 92713, (714) 833-2400.

In Europe, contact Varian Associates Ltd., Molesey Road, Walton-on-Thames, Surrey, England, Telephone 26-766.

**Helping a Fast
World Move
Faster**

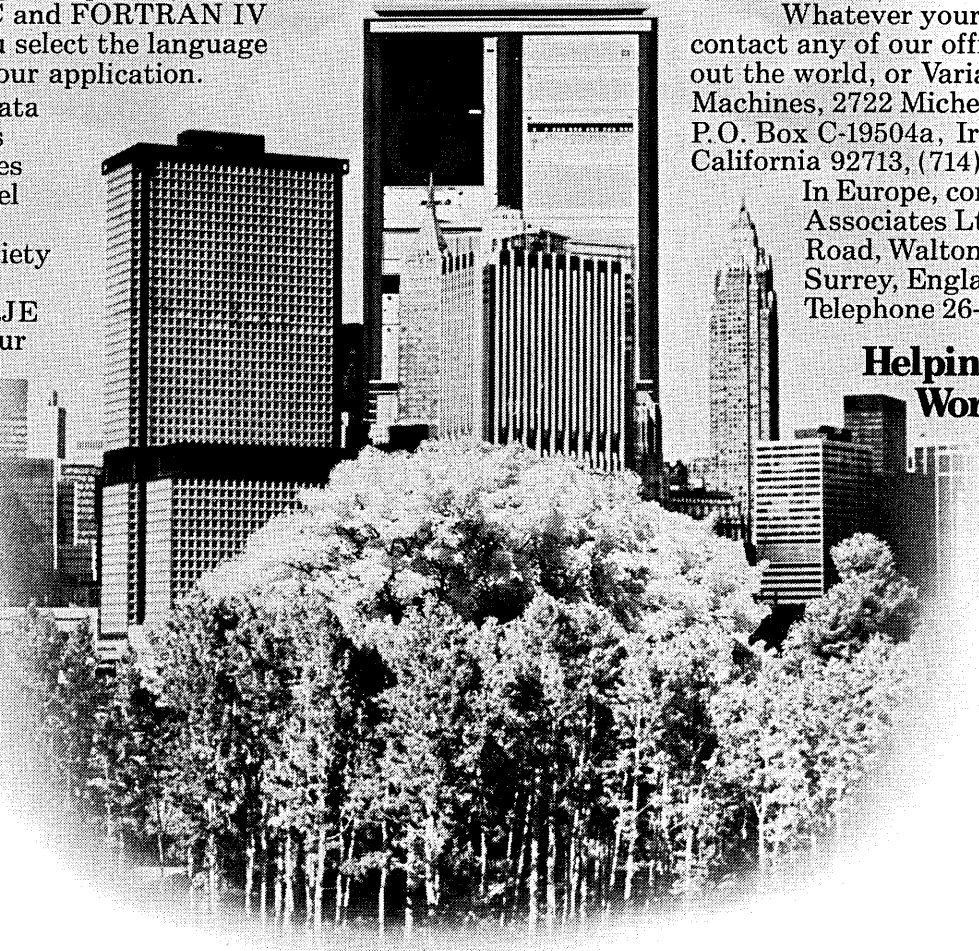

software & services

Updates

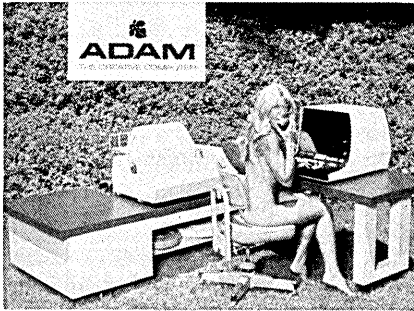

A rib to women's libbers? The Logical Machine Corp., Burlingame, Calif., is trying to convey the following attributes of its machine on the cover of its first brochure. (Pick one.)

- A. It's byte oriented.
- B. It's not just another garden variety business system.
- C. Women were created to sit at keyboards.
- D. The company is turning over a new leaf.

The answer is B, of course. The creation of Englishman John Peers, ADAM is a clever little business system that is pitched as not requiring software support, being programmed entirely in English (or Polish, or any language) by non-dp personnel. The new firm has orders for \$3.5 million of the machines, and has set up distributorships in Miami, South Africa, and Australia.

Anyone interested in forming an independent users group for IBM 7090/7094/7094II systems should contact Terry Harris at Indiana State University in Terre Haute, 47809. The university has had the 7090 up since 1973 and is so satisfied with its performance that they plan on keeping the second generation machine for the foreseeable future. Mr. Harris, in the physics department, can also be reached at (812) 232-6311.

Debug Dept. The Mini Virtual Memory product developed by Snyder Associates, Inc. (Sept., p. 154) does not segment the Data General run time library, as described, but rather various FORTRAN arrays selected by the programmer.

All signs indicate that structured programming techniques are catching on—especially the bumper sticker signs seen in the San Francisco area recently reading "Programmers do it top down."

System Tuning

If ever there were a software package that should be rated "R," ASSIST is it, for the package is a powerful tool to use in the real-time tuning of medium and large scale IBM 360 and 370 users. Fully 35 real-time commands are provided operators and systems programmers for analysis and solution of key day-to-day problems for which there are no OS, VS, HASP, or ASP solutions. Running from a 12K region/partition, ASSIST provides for analysis and recovery from system enqueue conflicts; shared DASD reserve lockouts; jobs looping or in a wait state by displaying cpu and EXCP activity over the last 30 seconds; and from missing I/O operations for both batch and on-line systems. The cpu activity can be redistributed among active jobs; the paging rate can be altered in vs systems; and the capability to change job dispatching priority is offered. Disc space allocation is performed by unit, generic name or address; permanently mounted disc devices can be unloaded; and strings of operator commands and JCL for operational jobs such as disc backup can be stored in a program data set and executed with a single

software spotlight

Information Management

NOMAD is an information management system designed specifically for time-sharing users by one of the largest time-sharing services vendors in the world. It consists of a set of commands for scanning through a data base, edit-like commands for locating and maintaining data, a general data management command for loading and maintaining files from transactions, and a comprehensive set of report writing commands. The system is described as a single command level system since all commands can be used in any order at any time. There is also a procedural language complete with its own compiler that allows interactive data management routines to be built for more complex transaction processing or for generation of special reports. File structures accommodated include sequential, external-file sequential, indexed sequential (with the external file organized in sequential form), and multi-path hierarchical.

There are a number of well thought

out features that should interest potential users. Firstly—and this should be a *must* for systems of this type—there are no rounding errors to consider in calculations. Numbers as large as \$10 trillion are stored, accurate to the penny through all computations. The system has been designed to be as nearly "crashproof" as possible on updates to the data base, and recovery is said to be easily accomplished. Security considerations did not escape the designers' considerations: data base subdescriptions and passwords can be used in limitless combinations to ensure that users only gain access to information they need to know. Where information is limited to a user by password or file clearance, no indication exists that there is additional information in the file—a feature that won't help snoopers much.

FOR DATA CIRCLE 213 ON READER CARD

Crt Formatting

Quick Change Real-Time (QCRT) is described as an on-line processor, a package that lets users set up on-line crt inquiry, edit, and update formats and specify the corresponding editing, validation and processing—something like a report generator. It's claimed that QCRT is so easy to use, even non-programmers can set up simple on-line inquiry, or even data entry applications. Three forms are used, plus a simple record definition for crt screen formatting, data manipulation, and table lookup. Response times for the package are said to be as good as most customized programs. A 360 or 370 with approximately 50K bytes of memory is required. QCRT runs under CICS, and with other communications systems without additional charge. QCRT will soon be priced at \$25K, but

Complete with training, NOMAD isn't cheap at \$100K. On the other hand, the new from the ground up package is billed as being sophisticated enough to perform the kinds of data base tasks performed by such DBMS as ADATABASE, IMS, and TOTAL which can cost more. First installations are underway. NATIONAL CSS, INC., Norwalk, Conn.

FOR DATA CIRCLE 212 ON READER CARD

asi/inquiry

The IMS DB/DC QUERY LANGUAGE

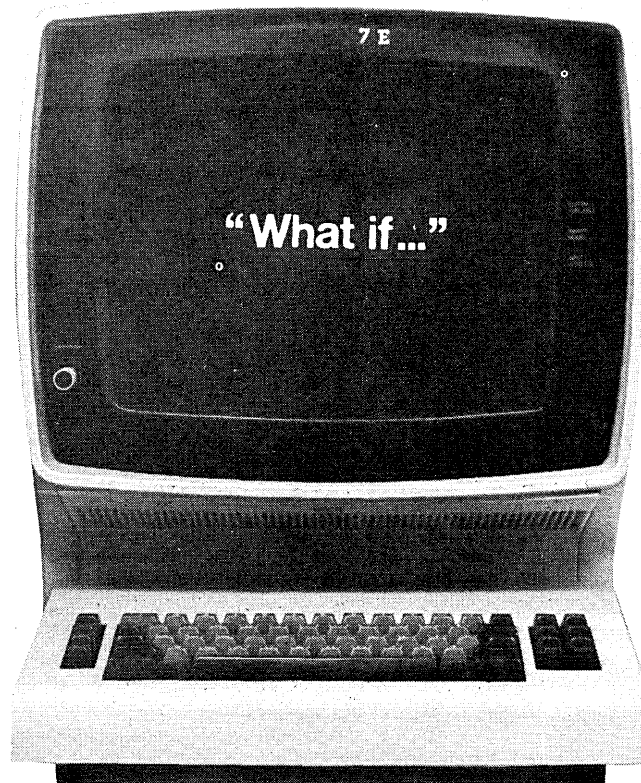

ASI/INQUIRY is an IMS DB/DC query language that operates completely as an interactive Message Processing Program. The design of ASI/INQUIRY is such that the *structure of the data base is transparent to the user*. Moreover, one need not have familiarity with DL/1 segment logic or the complexities of multi-pathing. Extremely rapid response time is assured.

MAJOR HIGHLIGHTS

- End-user oriented
 - Easy-to-use language
 - Requires no knowledge of IMS
 - Comprehensive diagnostic messages
- Rapid response time for even the most complex queries
- Dynamic priority scheduling to maximize system performance
- Availability of default as well as user-defined screen formatting

ASI/INQUIRY has been fully operational for over six months, and is currently installed in multiple sites here and in Europe.

In summary, ASI/INQUIRY represents the state-of-the-art product in an IMS DB/DC environment. It is the only system combining an easy to use language, complete user flexibility, and rapid response time in a single package. If you want to start answering "What if" immediately, call or write today for further information.



The Software Manufacturer

Applications Software, Inc.
Corporate Offices
21515 Hawthorne Boulevard
Torrance, California 90503
(213) 542-4381

software & services

a special introductory offer, which limits its use to a single application, can get you the package for as little as \$10K. A hardcopy generating module is also available for QCRT. THE MANAGEMENT GROUP, INC., Waltham, Mass.

FOR DATA CIRCLE 214 ON READER CARD

Technology for Sale

CDC has found a new use for its giant multination CYBERNET system by developing TECHNOC, a service in which CDC acts as a middleman in bringing together buyers and sellers of technology. Given a sendoff by Board Chairman William C. Norris, the pitch is that if the world is to cope with such critical problems as industrial and agricultural production, social services, education and housing while doubling in population in the next 30 years, it is essential that the flow of technology to the developing nations be assisted by computer technology.

The interactive technology marketing service uses a data base not provided by CDC but rather built upon the

input of those who have ideas to sell. Subscribers use keyword selectors to search files and make contact with the potential seller of the idea. The system is somewhat analogous to newspaper classified advertising in that the seller pays more than the buyer for the privilege of having the idea examined. If the potential buyer wants to contact the originator of the "ad," there is a minimum fee to CDC of \$50. Placers of the ads pay a listing charge of \$0.10/year for each character stored. Technologies high on the list for early users are thought to be food processing and energy. CDC plans to connect the system to the public telex/TWX networks which will permit the 500,000 subscribers to these systems to use TECHNOC with a minimum of effort. CONTROL DATA TECHNOC, INC., Minneapolis, Minn.

FOR DATA CIRCLE 215 ON READER CARD

Time Dependent Data Analysis

TIDEDA is an IBM FORTRAN and BAL program for collecting, collating, checking, correcting, and analyzing time dependent data. The program was originally developed by the New Zealand Ministry of Works and Development to process riverflow data in particular, but can be used in other similar applications. The program assumes

that a series of discrete values are joined by straight lines and so may always be graphed as a curve against time. Thus, air temperature can be represented as a line on a graph paper to indicate the temperature level as it varies with time. The program typically requires a single value to describe a property (temperature, for example) but sometimes requires a number of values like the three components of velocity. TIDEDA operates in interactive mode, uses the IBM Continuous System Modelling Program, and outputs in Calcomp plotter formation a nine-track tape. The program is priced at \$900; documentation is \$27. COSMIC, UNIV. OF GEORGIA, Athens, Ga.

FOR DATA CIRCLE 216 ON READER CARD

More S/32 Packages

Three more vertical industries are offered applications programs for IBM's System/32 small business minicomputer, including the hard goods industry, and tobacco and candy industries.

Billing, accounts receivable, sales analysis and inventory control programs are offered hard goods businesses in the appliance, electrical and electronics, hardware, plumbing, heating and air conditioning; industrial supplies, and paints and chemicals industries. The package comes in two different configurations for each of the

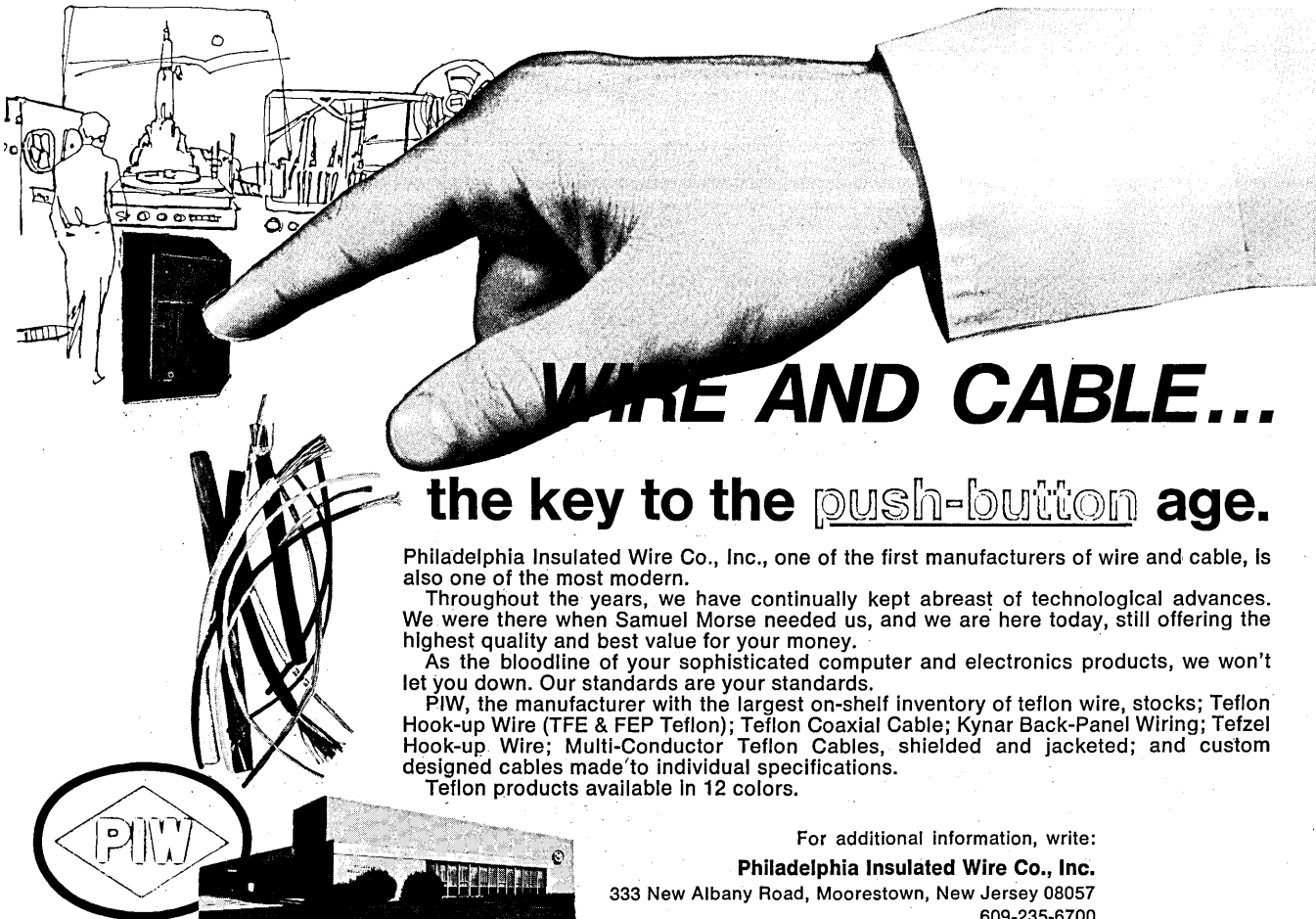

WIRE AND CABLE...

the key to the push-button age.

Philadelphia Insulated Wire Co., Inc., one of the first manufacturers of wire and cable, is also one of the most modern.

Throughout the years, we have continually kept abreast of technological advances. We were there when Samuel Morse needed us, and we are here today, still offering the highest quality and best value for your money.

As the bloodline of your sophisticated computer and electronics products, we won't let you down. Our standards are your standards.

PIW, the manufacturer with the largest on-shelf inventory of teflon wire, stocks; Teflon Hook-up Wire (TFE & FEP Teflon); Teflon Coaxial Cable; Kynar Back-Panel Wiring; Tefzel Hook-up Wire; Multi-Conductor Teflon Cables, shielded and jacketed; and custom designed cables made to individual specifications.

Teflon products available in 12 colors.

For additional information, write:
Philadelphia Insulated Wire Co., Inc.
333 New Albany Road, Moorestown, New Jersey 08057
609-235-6700

CIRCLE 96 ON READER CARD

There are two ways to convert to OS.

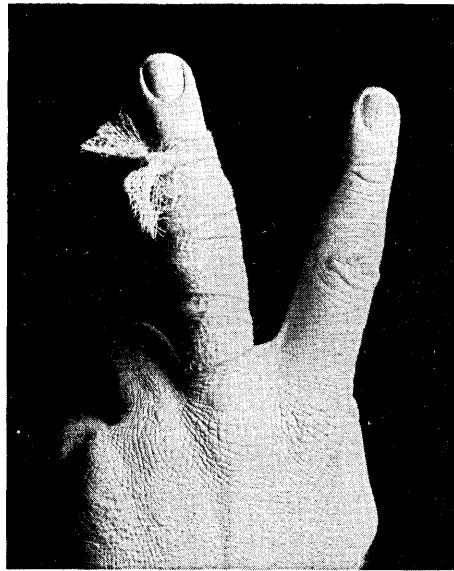

Converting to OS? There are two ways to do it. One is drastic and disruptive. The other is UCC TWO.

Without UCC TWO, changeover is a long-run nightmare. You have to re-write old programs while you try to design new ones. Months of solid confusion, hard work and down time. And one big, sudden expense. It's a good way to get burned.

With UCC TWO, it's business as usual. You continue to use your DOS programs—without reprogramming—while you make the conversion. You can plan the conversion to fit your work schedule, instead of the other way around. No re-IPing from system to system. In fact, you can even spread the job over months. And you can spread the cost. Pay as you go.

The choice is yours: Chaos. Or UCC TWO.

UCC TWO is one of the advanced software systems from the leader in operating software—UCC. Like you, we know there's more to software than installation. That's why we're the leader in long-term service and support, too.

Please send me more information on: DM 1175
 Have someone call me about:
 UCC ONE (Tape Management Software). A system that protects your data under OS operation. Provides real-time record of tapes, jobs.
 UCC TWO (DOS under OS)
 UCC SIX (PDS Space Management). Automatically inventories and controls OS disc space. Minimizes PDS compression requirements and disc investment. Saves programmer and machine time.
 UCC TEN (Data Dictionary/Manager). For IMS users, this system centralizes, controls data definitions, provides powerful cross reference features, automatically generates data base control statements, facilitates new systems design.
 UCC FIFTEEN (Restart Management System). Saves hours on restarting OS jobs. Simple, sophisticated software automatically corrects OS catalog, GDG biases before you rerun or restart.

Name _____
Title _____
Company _____
Address _____
City/State/Zip _____
Telephone _____

Mail to UCC, Software Products,
P. O. Box 47911
Dallas, Texas 75247.
Or call (214) 637-5010

When you have
the best people, you
have the best
product.

UCC
UNIVERSITY COMPUTING COMPANY

7200 Stemmons Freeway P. O. Box 47911 Dallas, Texas 75247
A Wyly Company

software & services

six supported industry areas. The first level package contains billing, accounts receivable and sales analysis. It's priced at \$2,500 plus \$120/month. The second, more comprehensive package includes billing, accounts receivable, inventory control and sales analysis and is priced at \$2,975 plus \$140/month. The billing program can perform such duties as recording item serial numbers on invoices for appliances covered under manufacturer's warranty or fire-arms for serial number registration. The systems also enable the distributor to determine on a regular basis the gross profit, both dollars and percent of business, produced by each salesman, from each customer or each item class; generate picking slips, handle pricing, aid with inventory analysis, etc.

FOR DATA CIRCLE 218 ON READER CARD

Billing, inventory control, sales analysis and accounts receivable programs are also the "front four" offered the wholesale candy and tobacco industry. The programs are designed for users with from 1,200 to 2,000 customers

and from \$1-7 million a year in sales. The billing module includes order entry and edit, a slot-sequenced invoice to go with the order, an audit trail of the daily billing, and a daily salesman's recap. Data is also extracted for input to the other three modules. Inventory control produces reports designed to highlight inventory behavior according to profitability, cost, item usage and ordering efficiency. Sales analysis generates sets of sales reports summarizing the activity and performance of items, customers and salesmen both in detailed or summary report form. Accounts receivable supports a mixture of open item and balance forward customers and includes on-demand printing of the aged trial balance. Both monthly and weekly statements and aging are supported. There is an initial charge of \$2,975 for the package, plus \$140/month. IBM CORP., Atlanta, Ga. FOR DATA CIRCLE 219 ON READER CARD

Payroll/Personnel/Pension

If yours is one of the organizations that's just beginning to feel the brunt of recent legislative enactments, specifically EEO, OSHA, ERISA, etc., this software and services vendor might have some "instant relief" available. Two of the most pressing problems faced by corporations, institutions,

governments and banking organizations throughout the U.S. are addressed by SUPER, those of pension and personnel processing, with extraction from payroll records being the key to the package. SUPER runs on IBM 360 and 370 equipment, is written in COBOL, and runs under the DOS, OS, and VS operating systems. In contrast to many package vendors, Wang claims it will fully support SUPER around the clock. Complete documentation is provided, including reference manuals, systems manuals, and operating and user instructions. Each SUPER user receives training for personnel who will be responsible for the system, and continuing introductory classes are offered at the firm's home site. A comprehensive maintenance/enhancement service is provided on an annual contract basis that assures users that their system will meet the latest government requirements: ERISA (Employee Retirement Income Security Act of 1974), EEO and OSHA for Personnel users, and federal (U.S. and Canadian), state (all 50), provincial, and local taxes for Payroll users. Prices range from \$25-75K depending upon which module is selected and optional features delivered with each system. WANG COMPUTER SERVICES, Tewksbury, Mass.

FOR DATA CIRCLE 217 ON READER CARD

The IDMS user's group keeps you right at the leading edge. It's database state-of-the-art plus a step beyond.

Customers who've attended user's group meetings for other types of software packages tell us there's something different and refreshing about an IDMS meeting.

"You people actually want to listen," they tell us.

And do we listen! Because through listening we've made IDMS the most advanced system in the industry. As far back as 1971, when IDMS was first conceived, it was done in compliance with the recommendations of a user-oriented group—the CODASYL committee.

And the many subsequent enhancements to IDMS have come from our attention to users' growing needs, many brought forth by the IDMS Technical Advisory Committee, which is made up entirely of users.

This atmosphere creates an exchange of ideas which, when implemented by the Cullinane technical staff, does in fact keep our users a step beyond the database state-of-the-art.

With a new 4.0 release soon to be announced, the next user's meeting will be exciting. Hope you'll be there!



Cullinane Corporation

Wellesley Office Park, 20 William St.,
Wellesley, Mass. 02181. (617) 237-6601



CIRCLE 83 ON READER CARD

When the Ramada Inn makes a promise, we put it in writing.

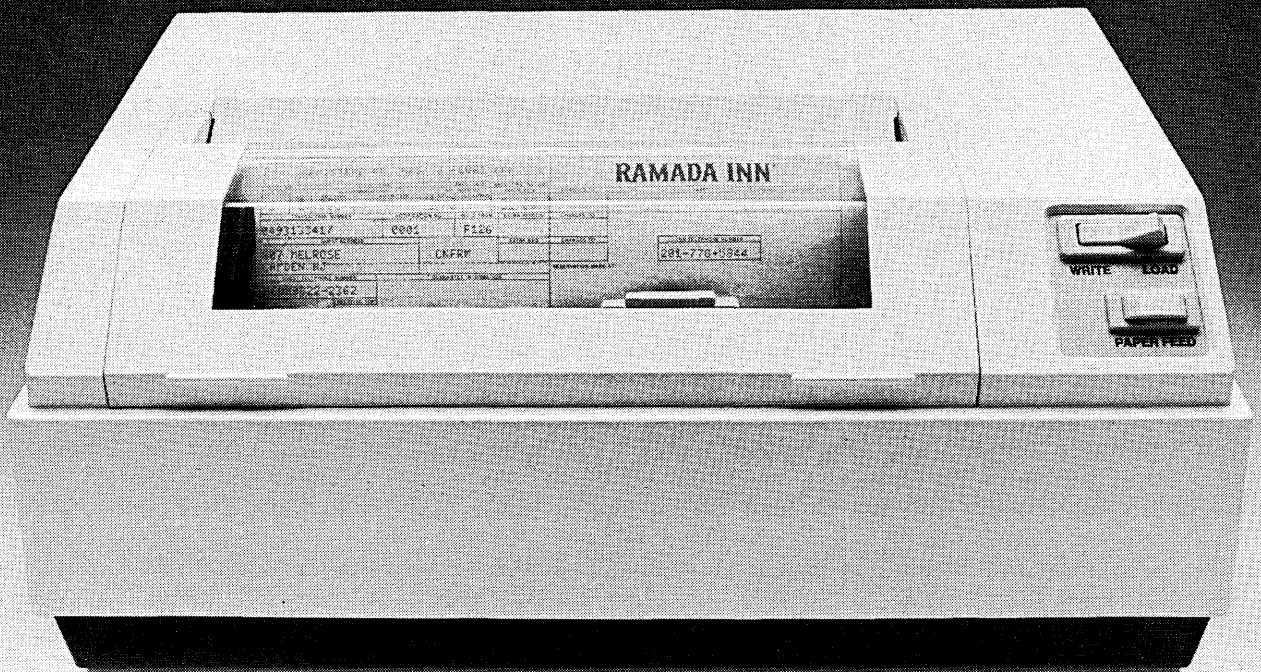

Any one of our competitor's page printers can print Ramada Inn's reservations.

And some of them can do it faster than ours.

But Ramada Inn chose our 4553 that operates at 15 ch/s. Because what we don't offer in speed, we offer in reliability. Which makes this specific machine perfect for their needs. But if you need something faster, we also offer our 4554 that operates at 60 ch/s.

Both machines are of relatively simple design and very inexpensive. Also, neither machine requires a ribbon when they print information. Our use of helix and hammer design to form the 5 x 7 dot matrix produces an extremely clear and easy-to-read print out.

And we're even easy to interface. The Facit 4553 and 4554 are obtainable for bit parallel (USASC II) data transmission and serial data transmission.

At Facit, we put a lot of work into our machines so you can get a lot of work out of them.

The Facit 4553 and 4554—we don't have any reservations about them. For more information, just write to Facit—O.E.M. Division, 66 Field Point Road, Greenwich, Connecticut 06830.

 **FACIT**
Dedicated to Efficiency

advertisers' index

American Telephone and
Telegraph Company 83-90
Applications Software, Inc. 165
Applied Digital Data
Systems Inc. 38, 39
Anderson Jacobson 135
BASF Systems 16
BASIC Timesharing 42, 43

Beehive Terminals Cover 3
Bell & Howell Business
Equipment Group 33
Bell and Howell, Electronics
& Instruments Group 5
The Boeing Company 174
Bruning Division of Addressograph
Multigraph 79

Cadillac Associates, Inc. 142
California Computer Products,
Inc. 129
Cambridge Memories, Inc. 70
Cardkey Systems, A Division Greer
Hydraulics, Inc. 29
Centronics Data Computer
Corp. 6
Chafitz 78
Chemetron Corporation 105
Comnet 141
Computer Machinery Corporation .. 1
Computer Professionals' Book
Club 107, 108, 109
Control Data Corporation . 95, 150, 151
Cullinane Corporation 168
Cummins-Allison Corp. 159

The Typewriter

This marvelous machine
represented the
state of the art
in word processing
at the turn
of the century.



In Software Design, the Challenge is to stay ahead of Obsolescence!

Our client, one of the nation's largest and most prestigious equipment and systems innovators, is looking for individuals with outstanding technical credentials in the field of complex real-time software systems, preferably command and control, weapons, radar and communications. A background in some of these areas will be considered: Data Base Management; Radar & Communications System Programming; Radar, Weapons, Missile Simulation; Operating System Software Development; Real-time Software Design; Software Project Management; Weapon System Software Development; New Business Acquisition; Micro Programming Systems; Real-time Executive System Design; Computer Systems Architecture. If you have a successful background in some of these areas, we can offer long-term career opportunities that include attractive immediate rewards and extraordinary advancement potential. Please write in complete confidence to:

LRK ASSOCIATES, 6845 Elm Street, McLean, Virginia 22101
U.S. CITIZENSHIP REQUIRED

LRK ASSOCIATES

Representing an Equal Opportunity Employer M/F

Data Communications
Interface 176, 177
Data General 69
Data Products 13
DATAMATION 173
Datapoint Corporation 14, 15
Datran 36
Datum, Inc. Peripheral Products
Division Cover 2
Delta Data Systems
Corporation 178
Digi-Log Systems, Inc. 94
Digital Equipment
Corporation 20, 21, 120

Eastman Kodak Company, Business
Systems Markets Division 68
Electronic Memories & Magnetics
Corporation 4, 114, 115
Elgar Corporation 157
Entrex 104

Facit-OEM Division 169
Fenwal Incorporated 40
Fox-Morris Personnel
Consultants 180

Gates 143
Goodyear Aerospace Corporation .. 9
Gould Inc., Instrument
Systems Division 130, 131
Graphic Controls Corporation .. 65, 161

Harris Computer Systems 66, 67
Hewlett-Packard 19, 96, 97, 139
Houston Instrument, Division
of Bausch & Lomb 8

IBM 99, 100, 101, 102
Information Terminals Corporation . 44
Infoton 111
Interdata 74, 75

We'll service your mixed vendor system better than your mixed vendors.

Because at Raytheon Service Company we have *more* experienced field reps who are trained to service *more* types of equipment than any one else in the business – whether manufacturer or service company. We supply the very best in technical support and documentation back-up. So when Raytheon handles your service you don't worry about which piece of hardware is the problem, your RSC rep will troubleshoot the complete system. That's fast, and cost-efficient.

We're proving just how fast and cost-efficient our single-source service is for a growing number of mixed vendor system user/customers. Major national and international airlines. Leading industrial firms. And governmental agencies. They think single-source service makes sense. We do too. We'd like to show you why. For the whole story, contact Mike Salter, Director, Commercial Marketing, Raytheon Service Company, 12 Second Avenue, Burlington, Mass. 01803, (617) 272-9300.

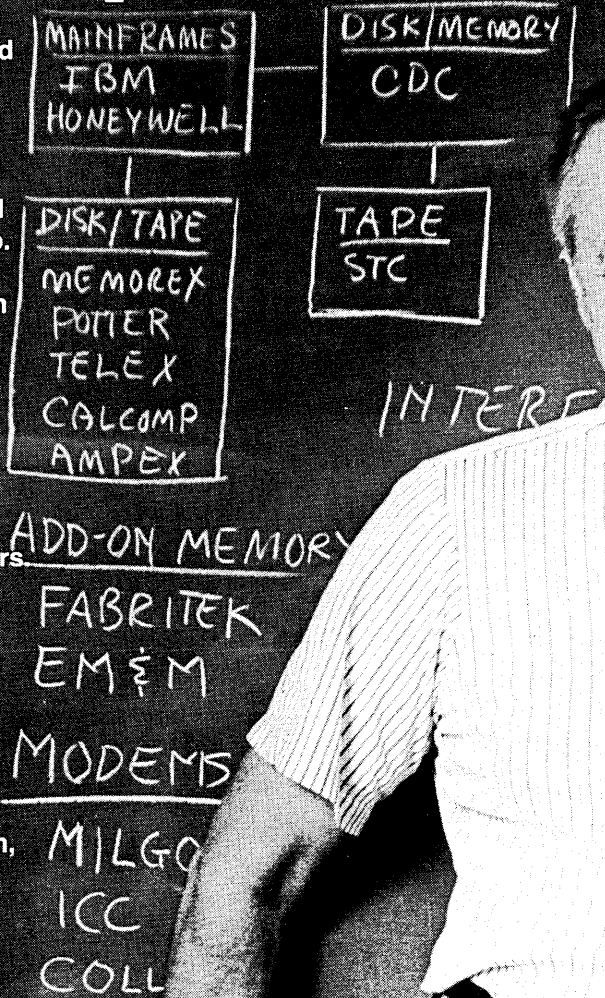

advertisers' index

Intermedia Systems	144
International Computer Equipment	103
ISS Sperry Univac	147
Intel Corporation	2
Lear Siegler, Inc., Electronic Instrumentation Division	127
Liebert Corporation	153
LRK Associates	170
MITS	175
Modular Computer Systems Inc.	154, 155
Mohawk Data Sciences Corp.	23
MMI Systems, A Division of Monolithic Memories, Inc.	124, 125
NCR Paper-Appleton Papers Division	136
NCR Data Processing Division	174
Numonics Corporation	98

Optima Enclosures, a division of Scientific Atlanta, Inc.	32
Penril Corp.	64
Pericomp Corporation	158
Pertec Peripheral Equipment Division	112, 113
Philadelphia Insulated Wire Programming Methods, Proprietary Software Division	166, 179
Program Products Incorporated	162
Qantex, The Peripherals Division of North Atlantic Industries, Inc.	35
Quest Systems Inc.	172
Raytheon Data Systems	26
Raytheon Service Company	171
Rockwell International, Commercial Telecommunications Division	144
Romac & Associates	172
RSVP Services	180
Rusco Electronic Systems	137
Salomon Brothers	98
Source EDP	160
Southern Simulation Service, Inc.	134
Sycor	30, 31
Systems Engineering Laboratories	73

Tab Products Company	118, 119
Tally Corporation	149
T-Bar Incorporated	116
TDK	134
Technical Publishing Company	92, 93
Tektronix, Inc.	41
Teletype Corporation	Cover 4
Termiflex	158
Texas Instruments Incorporated, Digital Systems Division	24, 25
Topaz Electronics	140
Trendata, An Applied Magnetics Company	80
United Air Lines	10
University Computing Company	81, 167
Varian Canada, Peripheral Products Division	145
Varian Data Machines	163
Wright Line, A Division of Barry Wright Corporation	37, 140
Zeta Research	138

Even Webster's Knows About QUEST

QUEST (kwest). v. 1. To make a search; to go on a quest.

QUEST SYSTEMS, INC. n. 1. A corporation founded in 1968. 2. The largest professional recruitment firm in the U.S. functioning solely in the computer sciences; its client companies pay all employment fees, interviewing and relocation expenses. Quest is known for its deep personal commitment to relate to each candidate as an individual with individual goals. 3. Its professional staff averages over 6 years of experience in EDP recruiting (additionally, staff members have direct hands-on experience in programming, systems, hardware sales, etc.) 4. Quest is presently searching for programmers and analysts (commercial, scientific, systems software) for over 3,500 client companies in the U.S. *Quest has openings in over 700 U.S. towns and cities.* 5. Methodology — see Questsystem.

QUESTSYSTEM (kwest sis'tem). n. 1. Discussing with an individual what he would like to be doing in light of what he has been doing. 2. Analyzing the realities of his objectives as they relate to the current job marketplace. 3. Contacting client companies and other Quest staff personnel to identify positions of possible interest. 4. Introducing the job candidate to his prospective employers by providing complete details to each about the other, ensuring the efficacious use of everyone's time. 5. Arranging interviews. 6. If employment offers are extended, Quest assists in evaluating the responsibilities, compensation and opportunities (and relates those to the initially stated objectives). The Questsystem has been working for thousands of professionals at no expense, whatsoever. Ask your friends of their past dealings with Quest. Then, put the Questsystem to work for you. For additional information on this subject, please inquire directly to Quest Systems, Inc. (All inquiries/resumes received will be responded to immediately and in confidence.)



QUEST SYSTEMS INC.

6400 Goldsboro Road
Washington, D. C. 20034 (301) 229-4200

Baltimore: (301) 265-1177 • Philadelphia: (215) 667-3322

CIRCLE 119 ON READER CARD

Bringing
the "right people"
together
takes Romac's
depth

Professional placement specialists in 14 Eastern locations. Romac offers more options to EDP, Accounting and Banking people. Our in-depth screening and experience are just two of the reasons why Romac brings the "right people" together.

Always in confidence, Always fee paid



ROMAC

& ASSOCIATES/Personnel Consultants

Contact Romac & Associates, President H. B. Dunn at 125 High St., Boston, Ma., 02110, for transmission to our network Partners in Manchester, Portland, Hartford, New Haven, Stamford, Rhode Island, Buffalo, Rochester, Syracuse, Wellesley Hills, Ma., Boston, Washington, D.C., Charlotte and Atlanta.

If you can think of a reason to advertise someplace else, we'll give you five reasons not to.

We're not saying there aren't good reasons for advertising somewhere besides DATAMATION. In fact, we'll give you one.

Suppose a sales opportunity opens up unexpectedly and you need to respond quickly with an ad. Placing it in the weekly newspapers in our field might just give you the flexibility you need.

But you'd still have a problem. Coverage.

Many of the people you want to sell would probably never see your ad. Because the closest these publications come to reaching the market DATAMATION covers is 30%. You'd end up spending almost as much in these publications as you would in DATAMATION and reach a lot fewer buyers.

But you don't depend on special situation ads to build your business. It's the regular advertising you do year after year that makes the difference. 12 ads a year in DATAMATION put you in front of all your customers every issue.

The same 12 ads in the weekly publications put you in 12 issues but not in the other 40. It's hard to get your buyer's attention when you don't advertise regularly.

So you don't think we've made a statement we can't back up, here are four more reasons why DATAMATION is the best place for you to advertise:

- EDP professionals like it best. (The major reader studies say so.)
- Advertisers like it the best. (The total advertising pages DATAMATION carries say so.)
- Ads in DATAMATION produce the most and the best sales leads. (Advertisers say so.)
- Many of your customers and prospects read DATAMATION exclusively. (They say so.)

There are actually more than five reasons why DATAMATION is the best place for you to advertise. But we'll save them until you think you have a good reason to advertise somewhere else.

 **DATAMATION**®
First in market coverage—worldwide.

© Technical Publishing Company

BOEING

Software and Computer Systems Engineering

Boeing Aerospace Company has career opportunities for experienced personnel in Seattle, Washington:

- SOFTWARE/COMPUTER SYSTEMS DESIGN ANALYSIS
- REAL-TIME OPERATIONAL SOFTWARE DEVELOPMENT
- DATA BASE MANAGEMENT SYSTEMS DEVELOPMENT
- MATHEMATICAL ANALYSIS AND ALGORITHM DEVELOPMENT
- SIGNAL PROCESSING SOFTWARE DEVELOPMENT
- SOFTWARE AND COMPUTER SYSTEMS TESTING AND EVALUATION

These assignments are for command and control and related applications. Prior airborne tactical anti-submarine warfare software design and or airborne acoustic system experience is highly desirable.

B.S. Degree in Computer Science or applicable engineering or science disciplines, 3-5 years related experience, and U.S. citizenship are required for these positions.

Please send your resumé to The Boeing Company, P.O. Box 3707-BBI, Seattle, WA 98124.

An equal opportunity employer.

BOEING

Getting people together.

CIRCLE 123 ON READER CARD

NCR

Data Processing Division - Wichita

NCR's Data Processing Division - Wichita has immediate openings for both junior and senior level engineers on **Advanced Development** and **Product Development** programs involving next generation minicomputer development.

MINICOMPUTER ENGINEERS

☆ SOFTWARE DESIGN ☆

- SYSTEM SOFTWARE ARCHITECTURE • OPERATING SYSTEMS
- COMPILERS • UTILITIES • COMMUNICATIONS

☆ HARDWARE DESIGN ☆

- PROCESSOR DESIGN • MEMORY DESIGN
- I/O CONTROLLER DESIGN • FIRMWARE DEVELOPMENT

☆ DESIGN SUPPORT ☆

- SEMICONDUCTOR COMPONENTS
- PERIPHERALS AND CONTROLLERS

Get all the details today. Send complete resume, including salary history and requirements to Ron Clarke, Professional Placement Office, P.O. Box 1297AS, Wichita, Kansas 67201.

CIRCLE 118 ON READER CARD



**Technical
Publishing Company**

Arthur L. Rice, Jr., Chairman of the Board
 James B. Tafel, President
 Gardner F. Landon, Exec. Vice President
 Calvered F. Jacobson, Financial Vice President
 and Treasurer
 Thomas A. Reynolds, Jr., Secretary
 M. Jay Turner, Jr., Director of Circulation
 Paul C. Jarvis, Director of Information Services

Advertising Offices

Eastern District Managers

A. Treat Walker,
 Warren A. Tibbetts: Greenwich, Ct. 06830
 35 Mason St. (203) 661-5400

New England District Manager & Vice President
 Warren A. Tibbetts: Manchester, N.H. 03104
 112 W. Haven Rd.
 (603) 625-9498

Midwest District Manager

John M. Gleason: Chicago, Ill. 60606
 205 W. Wacker Drive
 (312) 346-1026

Western Manager and Senior Vice President
 Hamilton S. Styron: Los Angeles, Calif. 90035
 1801 S. La Cienega Blvd.
 (213) 559-5111

District Manager

Alan Bolté, Jr.: Los Angeles, Calif. 90035
 1801 S. La Cienega Blvd.
 (213) 559-5111

Western District Manager

James E. Filiatrault: Mountain View, CA 94043
 2680 Bayshore Frontage Rd.
 Suite 101
 (415) 965-8222

U.K., Scandinavia, Benelux

Intergroup Communications, Inc.
 Wallace K. Ponder, European Director
 Paul D. Dimmock, Regional Manager
 31 Lyncroft Avenue
 Pinner, Middx. HA5 1JU
 England
 Tel: (01) 868 9289
 Cables: PACOM, Pinner

Germany, Austria, Eastern Europe

Fritz Taeuber
 Saltauer Strasse 85
 D-314 Lueneburg
 Germany
 Tel: (0 41 31) 3 19 34

France, Switzerland, Italy, Spain

Gerard Lasfargues
 32 rue Desbordes Valmore
 75016 Paris
 France
 Tel: (1) 288 90 22

Japan

Shigeru Kobayashi
 Japan Advertising Communications, Inc.
 New Ginza Building
 3-13 Ginza 7-chome
 Chuo-ku, Tokyo 104, Japan
 Tel. (03) 571-8748

Other



Magazines

Plant Engineering Pollution Engineering
 Power Engineering Purchasing World
 Research/Development Consulting Engineer

**Beat the Big One...
Heart Attack**

Give Heart Fund



Who is King of the MICRO-MOUNTAIN?

MITS is the King of the Micro-Mountain. If you have any doubts, just look at these options:

Altair 8800 —



The Altair 8800 from MITS is now one of the most successful computers ever delivered. Thousands of Altair 8800's have been sold and are in the field where they are being used for an infinite variety of industrial, business, science and home applications.

Built around the 8080 microprocessor chip, the Altair 8800 includes the CPU board, front panel control board, power supply (enough to power any additional cards), and expander board (with room for 3 extra cards) all enclosed in an aluminum case. Up to 16 cards can be added inside the main case.

Options for the Altair 8800 include a wide variety of memory and interface cards, Altair Floppy Disc, Altair Line Printer, audio-cassette tape interface, A/D converter, computer terminal, teletypewriter and more.

Software includes assembler, text editor, system monitor, DOS and a revolutionary BASIC language that byte for byte is the most powerful BASIC ever developed. Features of Altair BASIC include machine level I/O, multi-dimensioned arrays, multiple statements per line, etc. Altair BASIC comes in a 4K, 8K and EXTENDED (12K) version.

The Altair 8800 sells for \$439 in kit form and \$621 assembled. These are single quantity prices. Contact the factory or one of the MITS representatives for OEM pricing.

\$439

The Altair 680 is a complete computer built around the 6800 microprocessor chip. It comes with power supply, front panel control board, CPU board with 1K RAM (2102 type 1024 x 1-bit chips), built-in I/O that can be configured for RS232 or 20mA current loop or 60mA current loop, and provisions for 1K or ROM or PROM—all enclosed in an 11" wide x 11" deep x 4 1/16" case.

The Altair 680 is now selling at a special introductory price of \$293 in kit form and \$420 assembled. A turnkey model is \$240 in kit and \$280 assembled.

Software for the Altair 680 includes a PROM monitor, assembler, debug, and editor.

The Altair 680 CPU Board is selling for \$180 in kit form and \$275 assembled. Altair 680 prices are good until December 31, 1975.

Altair 680 —

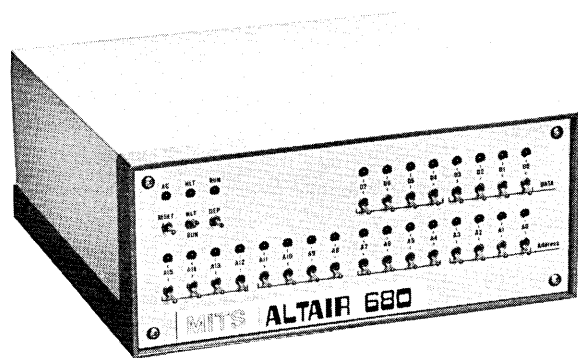

\$293

WANT TO HEAR MORE?

Contact the MITS sales representative in your area or call the factory direct: MITS/6328 Linn NE, Albuquerque, NM 87108, 505-265-7553 or 262-1952.

MITS, Inc.
Southeastern Regional Office
5508 NW 72nd Avenue
Miami, FL 33166
305-885-9388

Ridgway East, Inc.
173 Hawthorn Drive
Chagrin Falls, OH 44022
216-247-4845

COL-INS-CO, Inc.
1313 44th Street
Orlando, FL 32809
305-423-7615

CTI Data Systems
3450 East Spring Street
Long Beach, CA 90806
213-426-7375

BFA Corporation
3705 Westerfield NE
Albuquerque, NM 87111
505-292-1212

Inland Associates
13100 Manchester Road #G-25
St. Louis, MO 63131
314-821-3742

J. J. Wild, Inc.
400 Jericho Turnpike
Jericho, NY 11753
516-935-6600

REPCO
50 East Middlefield Road
Mountain View, CA 94043
415-965-8581

BFA Corporation
395 Lawdale Drive
Salt Lake City, UT 84115
801-466-6522

Data Electronics, Inc.
4976 N. Milwaukee Ave.
Chicago, Ill. 60630

Specifications, price, delivery subject to change.

COME ON DOWN

**TO NUMBER FOUR
BIGGER AND BETTER
THAN EVER BEFORE**

INTERFAC
INTERFAC
INTERFAC
INTERFAC

INTERFAC '76

Fourth Annual Presentation
of the Original National Data Communications
Conference and Exposition

MARCH 29-31, 1976 • MIAMI BEACH CONVENTION CENTER • MIAMI BEACH, FLORIDA

Cosponsored by **DATAMATION** magazine

Put on Your Most Winning Combination

DataComm Interface, Inc. — the originators and sponsors of Data Communications INTERFACE '73, '74 and '75 — and DATAMATION magazine — the most prestigious, informative, and widely read publication in the field — together will bring you the INTERFACE '76 Conference and Exposition during March 29-31, 1976 at the Miami Beach Convention Center in Miami Beach, Florida.

Program Committee

The INTERFACE '76 Program Committee has been appointed and, in conjunction with leading data communications users and suppliers, is already formulating program policy and procedure as well as coordinating speaker selection and session content. It's members, all thoroughly experienced in the area of data communications, are Ralph Berglund, Vice President of Kranzley and Co.; Richard L. Deal, President of Richard L. Deal and Associates; Dr. Dixon R. Doll, President of DMW Telecommunications Corp.; Philip H. Dorn, President of Dorn Computer Consultants, Inc.; Dr. Philip H. Enslow, Jr., Associate Professor, Georgia Institute of Technology; Phil Hirsch, Editor of DATA CHANNELS; Richard A. Kuehn, President of RAK Associates; Robert A. Lively of Creamer, Trowbridge Case and Basford, Inc.

The combined talents of the Program Committee and their associates will help to make INTERFACE '76 the most successful data communications conference ever held.

New Expanded Program

To keep you current on the datacomm advances which have occurred with dizzying speed during the past year, we're going to broaden considerably the scope of the sessions. We'll have more topical sessions and speakers... new approaches to fundamentals... new presentations and formats... more "bottom-line" solutions to datacomm problems.

Old Favorites Back, Too

We'll have updated versions of such popular sessions as our dual Workshops. The Product Workshops will supply in-depth information on the latest data communications equipment and services together with practical advice on evaluation and selection. The Methods Workshop will deal with the methods, systems, and procedures needed to plan, implement, and manage a data communication network.

Another popular event from INTERFACE '73, '74, and '75, the Applications Sessions, will return with panels of experienced users detailing their successes in operating datacomm systems in many specific industries and application areas.

The Highlight Sessions will address topical issues that are likely to affect individuals and organizations working in today's datacomm environment.

The Little Red DataComm Schoolhouse

This conference pleaser from INTERFACE '75 will be repeated at INTERFACE '76 — with additional material. It's designed especially for newcomers, experienced datacommers who want to brush up, and managers and executives from other areas who want to get a handle on the exciting field of data communications.

Exhibits Unlimited

As in the past, INTERFACE '76 will have a dazzling array of the latest datacomm products and services from the industry's leading suppliers. You'll have a once-a-year opportunity in one place to evaluate the hardware, software, and systems that make things happen in data communications.

For further details, fill out coupon below and mail to INTERFACE '76
160 Speen Street, Framingham, Mass. 01701 (617) 879-4502

Mail today to:

INTERFACE '76
160 Speen Street
Framingham, Mass. 01701

NAME _____
TITLE _____
COMPANY _____
ADDRESS _____
CITY _____ STATE _____ ZIP _____
TELEPHONE NUMBER () _____

FOR ATTENDEES

- Count me signed up for INTERFACE '76. My check payable to DataComm INTERFACE Inc. for \$95 is enclosed. Please send hotel* information.
- Count me signed up for INTERFACE '76. Please bill me and send hotel* information.
- I am interested in attending INTERFACE '76. Please place me on your mailing list for further information.

FOR EXHIBITORS

- I am interested in exhibiting at INTERFACE '76. Please send me more information.
- *We've arranged especially low conference hotel rates.

the forum

The Dark Side of Structured Programming

Many positive things have been said about structured programming. Maybe the time has come to be somewhat negative.

The proximate cause of this article was a reading of IBM's Independent Study Program on Structured Programming [ed. note: A review appeared in the October issue, p. 27]. In it we learn that the flowcharting decision box is now a predicate node; the connector is a collector node; and the process box, a process node. We also learn that to convert our spaghetti-bowl flowchart thinking to structured thinking, we must master the techniques of interchange, transposition, combination, resolution, and substitution. With help like this, we may have nothing to worry about—structured programming may not survive.

Perhaps we should begin again. Let's try it with a not-so-

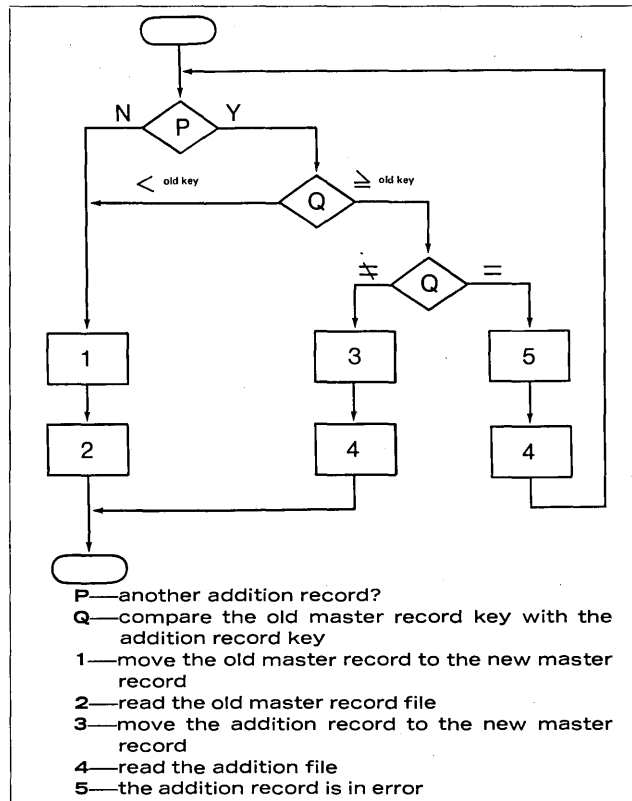
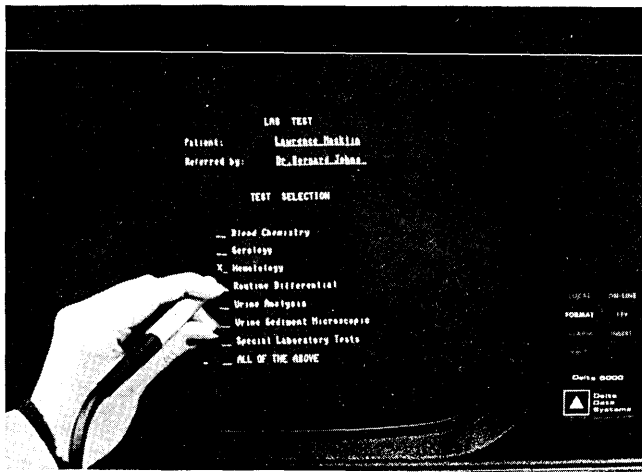

Fig. 1. A flowchart done the "old" way, of a common logical situation: merging additions to a master file.

	1	2	3	4
P ?	Y	Y	Y	N
Q (LESS THAN CASE) ?	—	N	Y	—
Q (EQUAL CASE) ?	—	Y	N	—
1	X	—	—	X
2	X	—	—	X
3	—	—	X	—
4	—	X	X	—

Fig. 2. The same situation as Fig. 1 presented in a decision table.



DELTA TERMINALS AND LIGHT PENS MAKE YOUR SELECTION EASIER

We make it easier to select the right terminal, and easier to select the right information on the terminal's display.

We've always made it easier for you to match your video display to your video display problem, by offering terminal features such as:

- 7x9 dot matrix for the most readable upper/lower case characters in the industry
- Custom keyboards designed for your special needs
- 3072 character memory
- 27 line by 80 character display
- Exclusive PAGING capability that permits recovery of top and bottom line rollofs

These and many other unique and useful features in DELTA 5000 video display terminals work to save time, money and effort, add convenience, minimize error possibilities and eliminate unnecessary computer time.

We want to make one more point about simplifying your selection. Our new light pen takes the time and tedium out of selecting required information on the display screen. The light pen is easy to use, accurate, and it can save considerable time. All DELTA 5000 terminals are available with a light pen as an option.

Now that we've told you how easy it is to simplify your terminal selection, we'd like to show you with a demonstration at your convenience. Contact us today to set one up, or for literature or applications assistance.



Delta Data Systems Corporation

Woodhaven Industrial Park
 Cornwells Heights, PA 19020
 (215) 639-9400

DELTA DATA SYSTEMS, LTD.
 London: 01-580-7621

new remark: From a general point of view, structured programming isn't a new thing. It's just another way of saying that you should organize and localize your code. However, don't think that by this remark, I mean to run down the structured programming concept. I don't. It shows how to organize and localize code in a methodical way, and that's to the good, since it allows us to minimize art and maximize procedure.

However, it's hard to overcome a strong sense of déjà vu, and with good reason, because we decision table devotees have been here before. The fact is that if you use decision tables to organize your program logic and adhere to one simple rule, you've organized your logic according to structured programming principles. The simple little rule is: No go to's in the action stub. Actually, there's one important exception to this rule, but rather than bother you with it here, I've buried it at the end.

Now, how do decision table and structured programming logic differ? The answer is shown in a nutshell in Fig. 1, which represents a common logical situation. The key at the bottom of Fig. 1 substitutes values for variables to transform the general case shown into a familiar specific one—the merging of additions into a master file.

Decision tables have no trouble with the logic shown. (See Fig. 2.) However, this common logic situation is the nemesis of structured programming—to express this logic in structured form requires the introduction of a flag (F), as shown in Fig. 3. So, yes, decision tables and structured programming do, on some occasions, produce different logical structures for the same situation, but in those in-

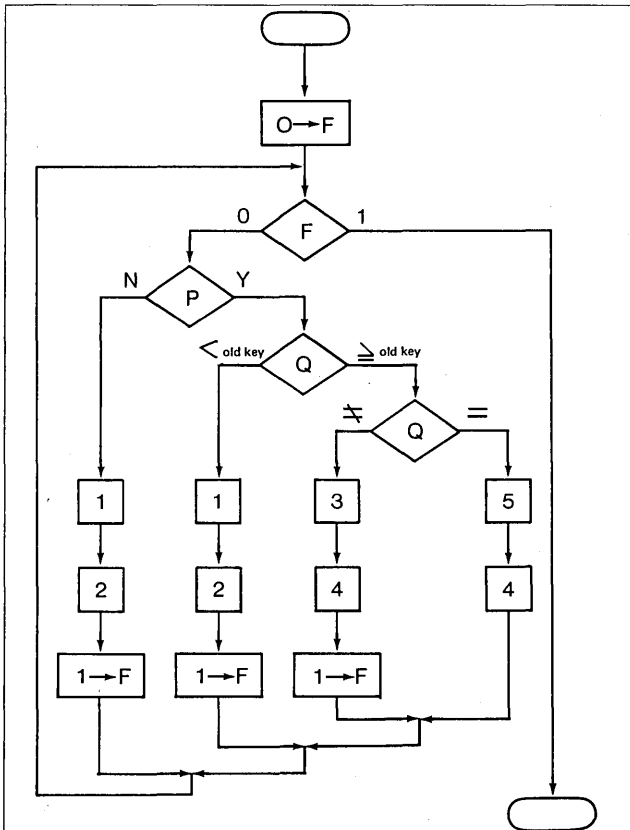

Fig. 3. Structured programming logic, applied to the same situation as Figs. 1 and 2, requires flags and increases in complexity.

stances where they differ, who needs the contortions of structured programming?

It could be contended that logic such as that shown in Fig. 1 should be allowed, and that otherwise, structured programming principles are to be followed. But now the door is ajar and who knows what other spaghetti bowls may creep in? Decision tables aren't hampered with the need for



THE ULTIMATE DATA COMPRESSION FOR ALL 360/370 USERS

While everyone else is ordering more disk drives you can turn some of yours back! **AMAZED?** It's easy with **SHRINK**, a general purpose superpowerful data compression package that uses a combination of many different techniques to achieve phenomenal data space reduction.

SHRINK's compression rates average from 20 to 85%. Here are some sample benchmark results of SHRINK's compression.

Previously compacted files with much binary data	20-30%
OS object decks	43%
Report type data files	70-85%
File data consisting of alphanumeric numeric and some binary items	60-80%

Compression/expansion is highly efficient requiring an average of only 1 CPU second per 100K bytes on a S/370/158. Sophisticated redundancy checking assures data integrity.

CPU overhead is minimized in random keyed retrievals and in transaction/master matching as only selected records need expansion. Further, compressed files can be sorted directly, reducing sort times and sort work space. SHRINK will speed up I/O bound jobs by permitting more records per block size and fewer volumes per file. SHRINK is easy to use from any batch or on-line program. Installation and training takes an hour. A no obligation trial is available.

- Ability to sort, retrieve or update compressed files without expanding them,
- Improved sort times and reduced sort work space requirements,
- Record compression/expansion subroutines callable in the standard manner from BAL, COBOL, FORTRAN, PL/I, etc.,
- Stand-alone file compression/expansion utilities,
- A guarantee that the expanded record is an exact replica of the original, before compression,
- Ability to be easily implemented in an on-line monitor environment,
- Reduction of turnaround time for I/O bound jobs resulting in more throughput in the computer as well as better job performance, and
- Reduction of tapes and disks, tape drives and disk spindles.

PROGRAMMING METHODS

Proprietary Software Division
1301 Avenue of the Americas
New York, N.Y. 10019

Send me details about SHRINK

NAME _____

Company _____

Address _____

Phone _____ CPU _____

PROGRAMMERS AND ANALYSTS

Free Employment Service

Serving Northeast, Southeast and Midwest U.S.

- Scientific and commercial applications
- Software development and systems programming
- Telecommunications
- Control systems
- Computer engineering
- Computer marketing and support

Call or send resume or rough notes of objectives, salary, location restrictions, education and experience (including computers, models, operating systems and languages) to either one of our locations. Or check the reader service card for a free sample resume. We will answer all correspondence from U.S. citizens and permanent residents and will guarantee our best efforts in a professional and ethical manner to all qualified applicants that we think we can help. Our client companies pay all of our fees.

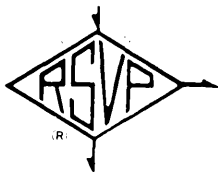

RSVP SERVICES, Dept. M
Suite 700, One Cherry Hill Mall
Cherry Hill, New Jersey 08034
(609) 667-4488

RSVP SERVICES, Dept. M
Suite 300, Dublin Hall
1777 Walton Road
Blue Bell, Penna. 19422
(215) 629-0595

RSVP SERVICES

Employment Agency for Computer Professionals

CIRCLE 121 ON READER CARD

EDP SEARCH

WHY IS FOX-MORRIS THE FIRST CHOICE OF EDP PROFESSIONALS?

A recognized staff of professional experts offering LOCAL, REGIONAL & NATIONAL COVERAGE through our direct branches as well as coast to coast coverage through our 75 member firms of National Personnel Consultants, Inc.

Completely confidential service geared to your career objectives.

Unparalleled contacts with industry based on years of successful results.

Professional resume evaluation and career guidance.

Client companies assume all employment costs—including interview expense, relocation (if necessary) and search fee.

SEND RESUME DIRECT, OR CIRCLE NUMBER BELOW ON READER CARD.

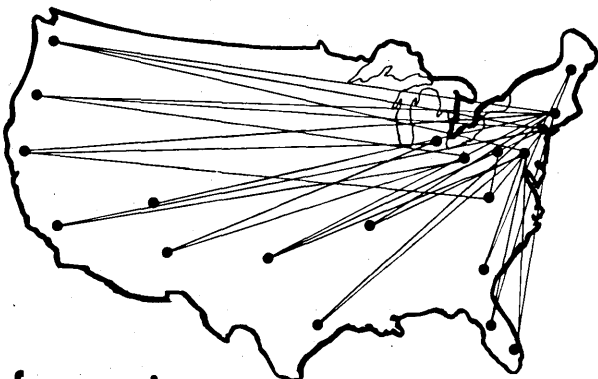

fox-morris personnel consultants

Philadelphia: (215) 561-6300, 1500 Chestnut St., Philadelphia, Pa. 19102
New York: (212) 697-1820, 633 Third Ave., New York, N.Y. 10017
Pittsburgh: (412) 232-0410, 6 Gateway Center, Pittsburgh, Pa. 15222
Wilmington: (302) 654-4465, 2005 Concord Pike, P.O. Box 7017, Del. 19803
Princeton: (609) 452-8135, P.O. Box 2063, U.S. Rt. 1, Princeton, N.J. 08540
Baltimore: (301) 296-4500, 409 Washington Ave., Baltimore, Md. 21204
Charlotte: (704) 527-4980, 4000 Park Road, Charlotte, N.C. 28209
Atlanta: (404) 321-3888, 2200 Century Pkwy., N.E., Atlanta, Ga. 30345

CIRCLE 116 ON READER CARD

the forum

any such compromises.

Decision tables have another advantage over structured programming. When you're finished with your decision tables, you can just turn them over to a preprocessor, and out comes your code. With a structured flowchart, you must still write all that COBOL code. And if you thought writing COBOL code made your hand hurt, wait until you write COBOL code in structured format. All those duplicate operations create a real temptation to slip in a few nice, simple GO TO's to avoid writer's cramp.

Preprocessed spaghetti

Now, it's possible to contend that while decision tables organize logic well, preprocessors turn out spaghetti bowls. True enough, but this is the same as saying that even if you avoid GO TO's in your COBOL code, the compiler is going to generate a lot of branches, which is true. The point is that you maintain programs at the level at which you write them, and with the use of preprocessors, you maintain your programs at the decision table level.

There's also the fact that with decision tables, there are automatic procedures which can be built into the preprocessor to:

1. guarantee that all possible combinations of conditions have been considered
2. eliminate all redundancy
3. detect all contradictions.

No flowcharting technique, including structured flowcharts, can claim to do all three.

That one exception

Here's the buried exception part mentioned earlier. Consider the situation in Fig. 4. Now, suppose that condition B depends on the outcome of action D. The situation then has

TABLE—X	1	2	3	4
CONDITION A	Y	Y	N	N
CONDITION B	Y	N	Y	N
ACTION C	X	X	—	—
ACTION D	X	X	X	X
GO AGAIN	X	—	X	—
EXIT	—	X	—	X

Fig. 4. The one case where the simple decision table like this presents difficulties without a GO TO is when condition B depends on the outcome of action D.

TABLE—X	1	2
CONDITION A	Y	N
ACTION C	X	—
ACTION D	X	X
PERFORM TABLE—Y	X	X
EXIT	X	X

TABLE—Y	1	2
CONDITION B	Y	N
GO TO TABLE—X	X	—
EXIT	—	X

Fig. 5. The situation of Fig. 4 with a GO TO in the action stub.

to be described as shown in Fig. 5. This is the only type of situation in which a GO TO action should appear in the action stub.

... once again

Going back to the starting point, if you use decision tables, you don't need to know anything about predicate nodes, collector nodes, process nodes, interchange, transposition, combination, resolution, and substitution. That alone should be enough to sell you on decision tables.

—Thomas R. Gildersleeve

Previously with Univac for 14 years, for the past six years Mr. Gildersleeve has been a consultant specializing in organization studies, and in developing project management procedures and system development standards.

BEEHIVE...adding to its family of terminals

"My new Mini Bee 4, Speedi-Bee 8, Super Bee 3, and Edit Bee terminals have recently joined the video display family at Beehive. They bring with them additional functions and features to satisfy a large variety of processing and data entry application needs. While these terminals are specially designed for specific applications, they are only part of the even larger line-up of Beehive terminals designed to meet the application needs common to many, and others designed to satisfy custom requirements. My new additions are already joining the thousands of Beehive terminals currently serving throughout the world. Beehive Terminals is a big family, doing a big job...all at a price completely unsuggestive of terminal performance capabilities. Your particular application need can be satisfied with a reliable and efficient Beehive terminal. Call, write or wire for an on-site demonstration."

SUPER BEE

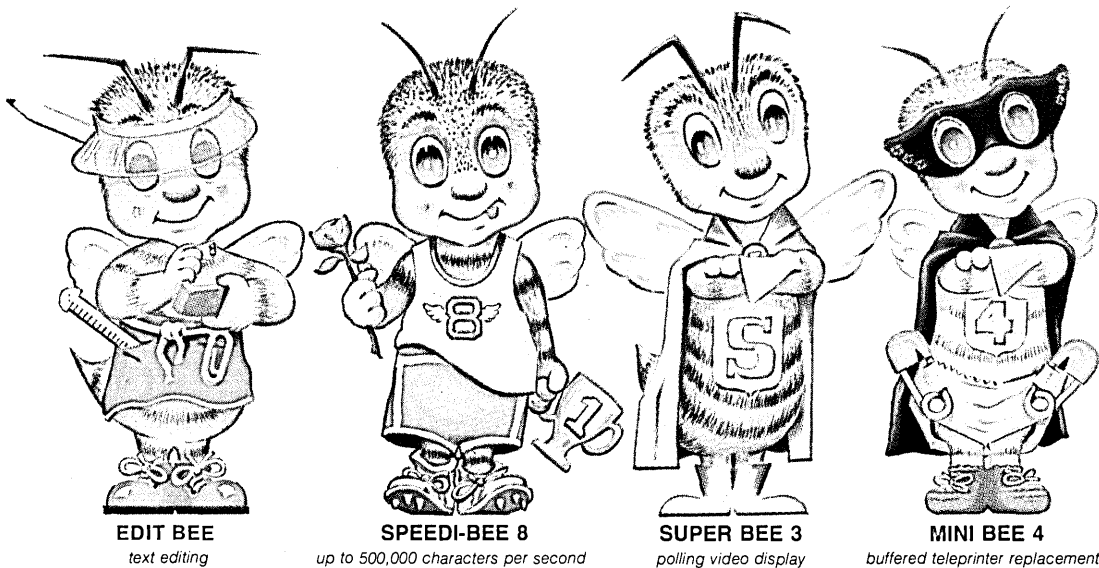

EDIT BEE
text editing

SPEEDI-BEE 8
up to 500,000 characters per second

SUPER BEE 3
polling video display

MINI BEE 4
buffered teleprinter replacement

BEEHIVE

Computer Systems,
Video Display Terminals
and Peripheral Equipment
for
MEDICINE, BUSINESS,
INDUSTRY, SCIENCE
and
EDUCATION

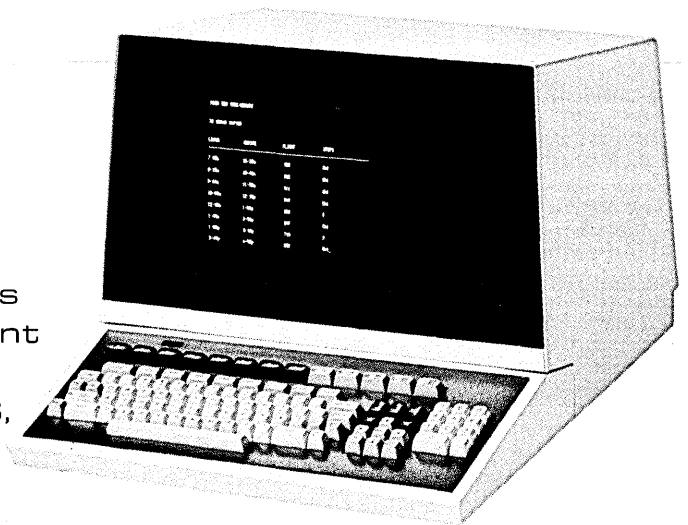

More Quality Products from

BEEHIVE TERMINALS

BEEHIVE MEDICAL ELECTRONICS, Inc.

870 West 2600 South • Box 19244 • Salt Lake City, Utah 84120 • (801) 487-0741 • TWX 910-925-5271

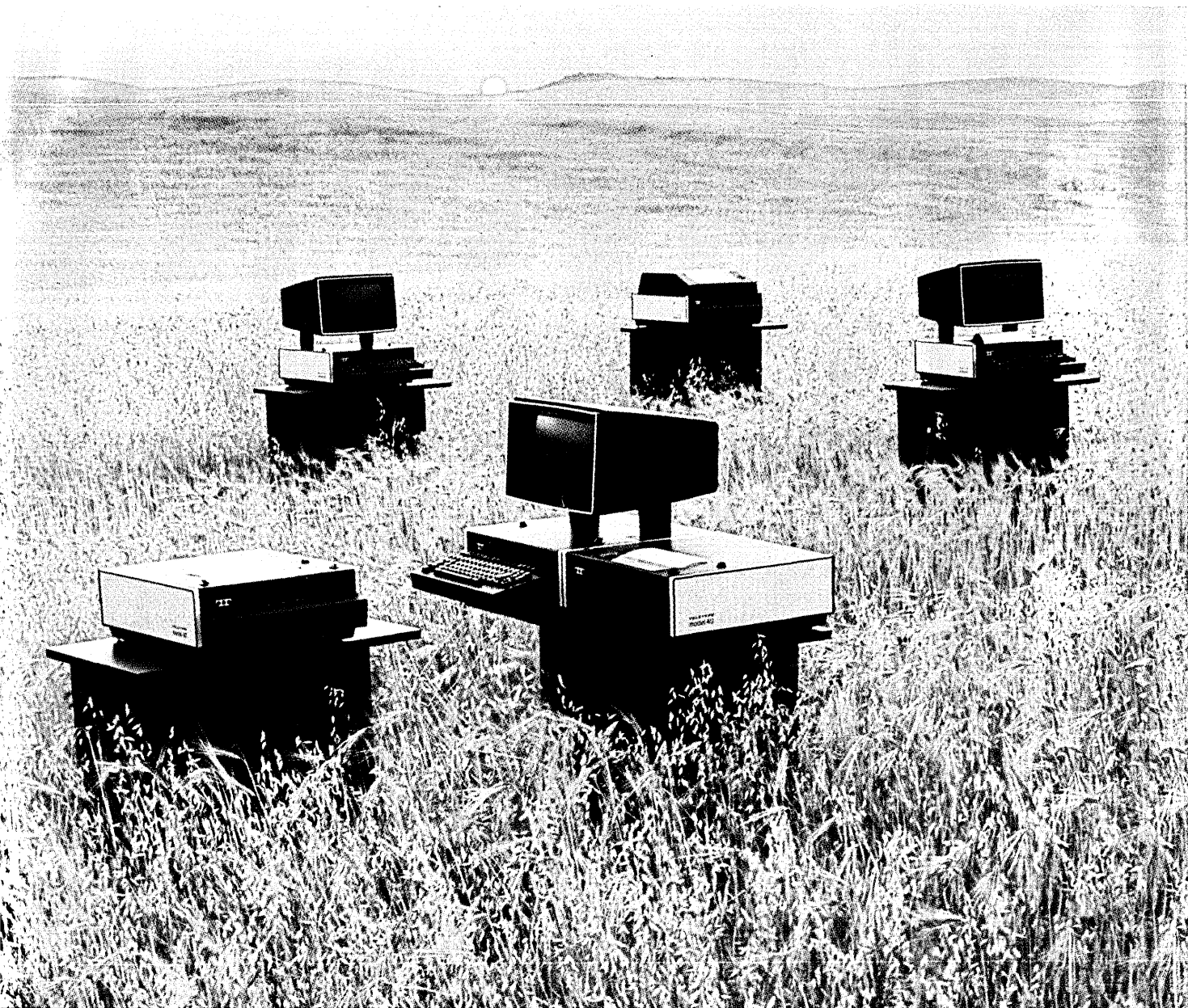

Where other data terminal systems grow old, this one is designed to simply grow.

The Teletype® model 40 is the data terminal system to start with because it's completely modular, and is designed to grow as your needs grow.

The display, operator console, printer and controller modules form the heart of the model 40 system and permit a variety of configurations to suit your application.

There's a wide range of options, too, such as expandable memory with scrolling; half/full duplex modes; fixed and variable field transmission; protected formats; a variety of on-line controls; current loop and EIA (RS232) interfaces; and speeds from 110 to 4800 bps. Printer options include 80 column friction and adjustable tractor feed units.

And don't worry about obsolescence. Since the model 40 design consists of separate modules, you can select only those capabilities you need now—and add others later.

Add it all up. The model 40 system offers outstanding reliability, versatility and economy. And delivery is sooner than you may expect. No wonder you can't beat the model 40 on a price/performance basis. To start with. Or to grow with.

For complete information, please contact our Sales Headquarters at: 5555 Touhy Ave., Skokie, Ill. 60076. Or call Terminal Central at: 312/982-2000.

Teletype is a trademark and service mark registered in the United States Patent and Trademark Office.



The Teletype model 40 system. Nothing even comes close.