

# electronics®

## NAVIGATING POLARIS SUBS

Simulator trains  
submarine crews

(photo below)

## LASER TRACKING

Applications of the  
injection laser

## INTEGRATED OSCILLATOR

Uses transistor  
and R-C line

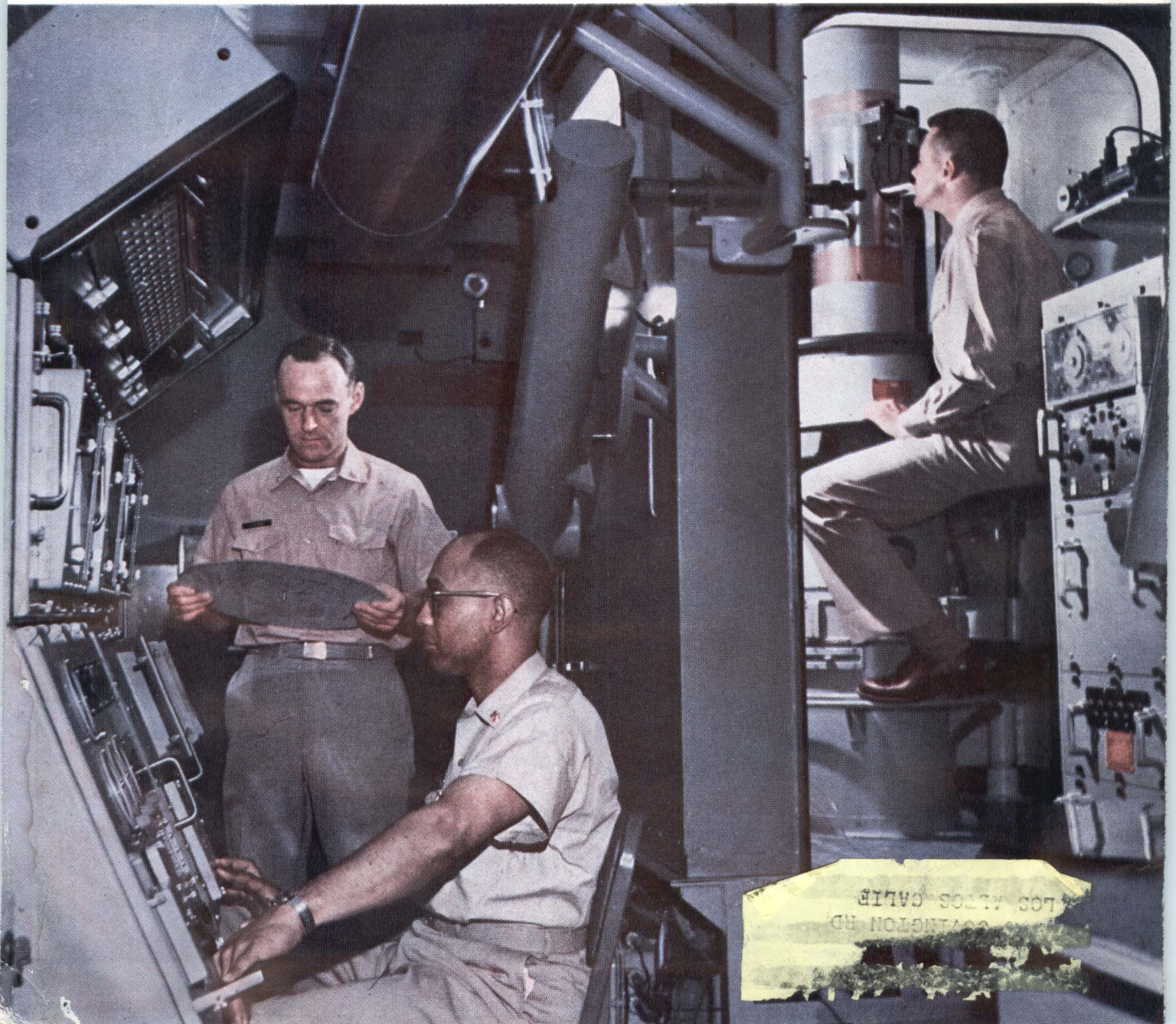

LOC ALLOS CALIE  
NOVEMBER 1963



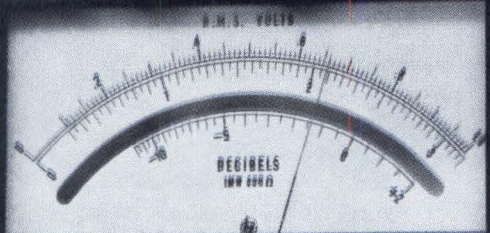
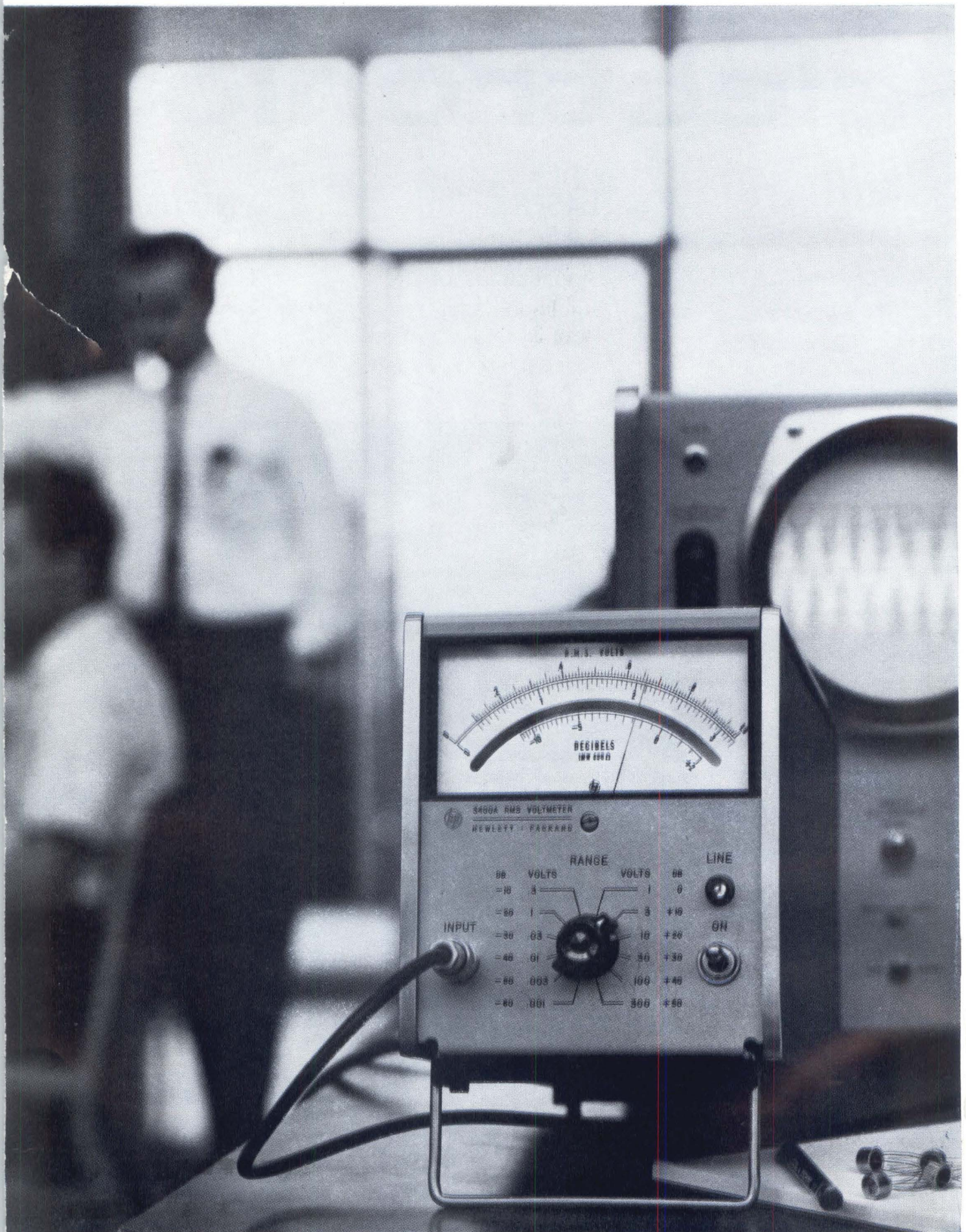

3400A RMS VOLTMETER  
HEWLETT - PACKARD

dB	VOLTS	RANGE	VOLTS	dB
-10	3	[Rotary Switch]	1	0
-20	1		3	+10
-30	0.3		10	+20
-40	0.1		30	+30
-50	0.03		100	+40
-60	0.01		300	+50

INPUT [Jack]

LINE [Switch]

OH [Switch]



# NEW ACCURACY!

True rms measurement of ac signals

- high crest factor
- linear scale, recorder output
- wide range, high accuracy
- compact, easy to use
- costs only \$525

Turn the page for all the details on the remarkable new hp 3400A RMS Voltmeter.

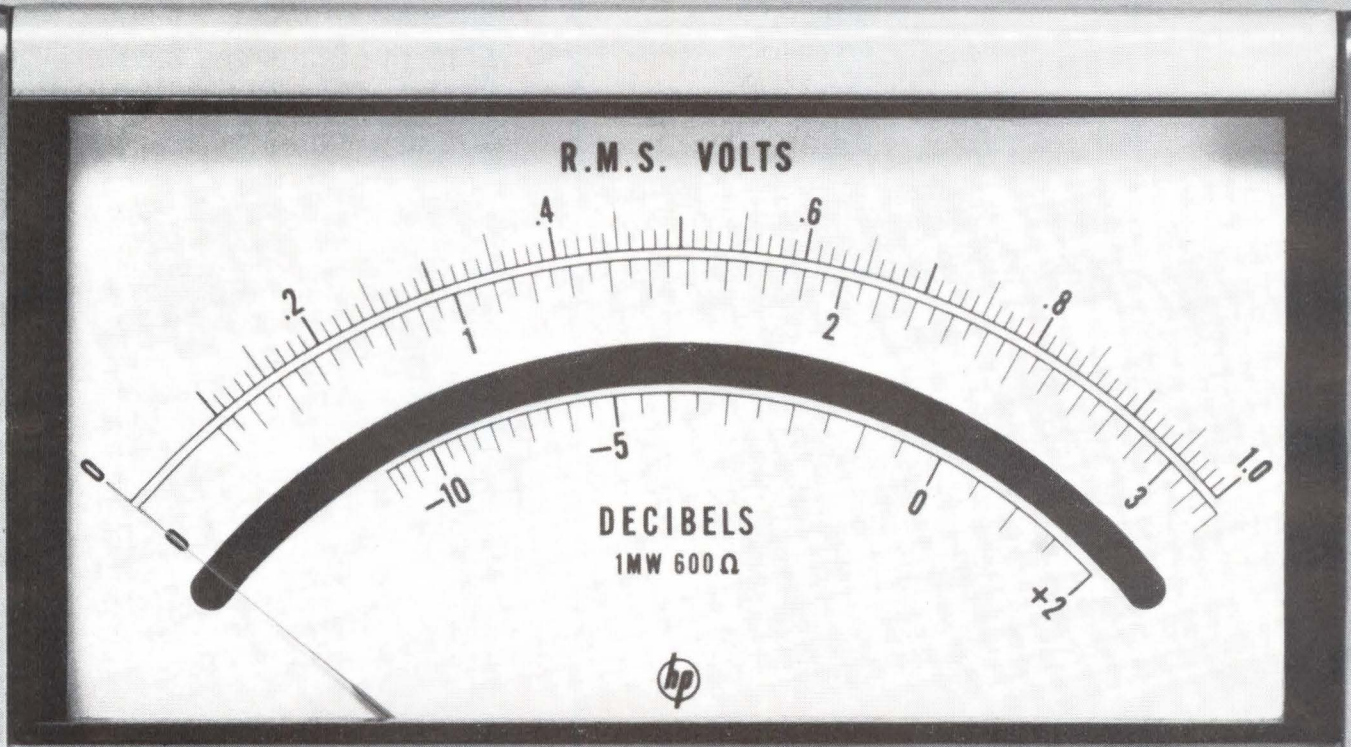

3400A RMS VOLTMETER  
HEWLETT · PACKARD



INPUT

RANGE

LINE

DB	VOLTS		VOLTS	DB
-10	.3		1	0
-20	.1		3	+10
-30	.03		10	+20
-40	.01		30	+30
-50	.003		100	+40
-60	.001		300	+50

ON



# NEW ACCURACY!

*A true rms voltmeter with this unprecedented combination of features:*

■ rugged taut-band meter ■ unequaled crest factor for accurate measurement of noise and pulses ■ linear scale for unparalleled resolution, plus linear dc output ■ full scale accuracy within  $\pm 1\%$ , 50 cps to 1 mc;  $\pm 2\%$ , 1 mc to 2 mc;  $\pm 3\%$ , 2 mc to 3 mc;  $\pm 5\%$ , 10 to 50 cps and 3 to 10 mc ■ measures 100  $\mu\text{v}$  to 300 v,  $-72$  to  $+52$  db, 10 cps to 10 mc ■ small, compact, easy to use...and costs only \$525

New hp Model 3400A measures the actual root-mean-square value of ac voltages from 100  $\mu\text{v}$  to 300 v, 10 cps to 10 mc. Precise rms measurements can be made of sinusoidal voltages or nonsinusoidal signals having crest factors (ratio of peak to rms) as high as 10 at full scale and as high as 100 at 10% of full scale deflection. Here is the ideal instrument for making accurate measurements of noise and pulse trains, without the need for correction factors.

The 3400A features 12 full-scale ranges, selectable by a front-panel switch which changes attenuation in accurate 10 db steps, permitting most readings on the upper two-thirds of the scale for highest accuracy and making possible a convenient scale calibrated from  $-12$  to  $+2$  db for measuring db from  $-72$  to

$+52$ . Rugged taut-band meter assures longer life under tough environmental conditions, provides accurate tracking despite repeated overloads. Meter scale is linear for high resolution; each scale is custom calibrated to match its particular meter movement.

For even higher resolution, the 3400A furnishes a dc voltage proportional to the rms value of the input, useful for driving accessories such as X-Y and strip-chart recorders or to drive a digital voltmeter.

The compact 3400A is only  $5\frac{1}{8}$ " wide and  $6\frac{1}{2}$ " high and weighs a mere  $7\frac{1}{4}$  lbs. And it's yours for only \$525! Call or write your Hewlett-Packard field engineer today for a demonstration of this remarkable true rms voltmeter.

## SPECIFICATIONS

**Range:** 100  $\mu\text{v}$  to 300 v rms; 12 full scale ranges from 1 mv to 300 v in a 1, 3, 10 sequence;  $-72$  to  $+52$  db

**Meter Scales:** voltage, 0 to 1 and 0 to 3; decibel,  $-12$  to  $+2$  db

**Frequency Range:** 10 cps to 10 mc

**Accuracy:** within  $\pm 1\%$  of full scale, 50 cps to 1 mc;  $\pm 2\%$  of full scale, 1 mc to 2 mc;  $\pm 3\%$  of full scale, 2 mc to 3 mc;  $\pm 5\%$  of full scale, 10 to 50 cps and from 3 to 10 mc

**Response:** responds to rms value (heating value) of the input signal for all waveforms

**Crest Factor (ratio of peak amplitude to rms amplitude):** 10 to 1 at full scale, inversely proportional to pointer deflection; e.g., 20 to 1 at half scale, 100 to 1 at tenth scale

**Response Time:** typically  $< 2$  sec to within 1% of final value for a step change

**Overload Protection:** 40 db or 425 v rms, whichever is less, on each range

**Maximum Input:** 425 v rms

**Input Impedance:** 10 megohms shunted by 25 pf

**Output:** negative 1 v dc at full scale deflection, proportional to pointer deflection; 1 ma maximum; nominal source impedance is 1000 ohms

**Power:** 115 or 230 v  $\pm 10\%$ , 50 to 60 cps, approximately 7 watts

**Dimensions:**  $5\frac{1}{8}$ " wide,  $6\frac{1}{2}$ " high, 11" deep

**Weight:** net  $7\frac{1}{4}$  lbs.

**Accessory Furnished:** 10110A Adapter, BNC to dual banana jack

**Price:** 3400A RMS Voltmeter, \$525

*Data subject to change without notice. Price f.o.b. factory.*

**HEWLETT  
PACKARD  
COMPANY**

1501 Page Mill Rd., Palo Alto, California 94304, (415) 326-7000. Sales and service in all principal areas. Europe, Hewlett-Packard S.A., 54 Route des Acacias, Geneva, Switzerland; Canada, Hewlett-Packard (Canada) Ltd., 8270 Mayrand St., Montreal, Quebec.



8182



**W. W. MacDONALD, Editor**  
Telephone Area Code 212 (971-2645)

**J. M. CARROLL, Managing Editor (2293)**

**SENIOR EDITORS**  
Samuel Weber (2371)  
George W. Sideris (3444)

**SENIOR ASSOCIATE EDITORS**  
Michael F. Wolff (2600)  
John F. Mason (2666)

**ASSOCIATE EDITORS**  
Michael F. Tomaino (2071)  
William P. O'Brien (2297)  
George J. Flynn (2188)  
George V. Novotny (3151)  
Leon H. Dulberger (3446)  
Alexander A. McKenzie (2685)

**ASSISTANT EDITORS**  
Stephen B. Gray (2245)  
Barry A. Briskman (2306)  
Dan Smith (2467)  
Joel A. Strasser (2127)  
Vincent S. Acunto (2592)  
C. R. Whetstone (3495)  
Eric Valentine (2710)  
Louis S. Gomolak (2472)  
G. G. Tirellis (2187)

**REGIONAL EDITORS**

Harold C. Hood,  
1125 W. 6th St., Los Angeles 90017, Calif.  
(213-482-5450)

Laurence D. Shergalis,  
John Hancock Bldg., 255 California St.,  
San Francisco 94111, Calif. (415-362-4600)

Thomas Maguire  
McGraw-Hill Bldg., 607 Boylston St.,  
Boston 02116, Mass. (617-262-1160)

Cletus M. Wiley,  
Blair Bldg., 645 N. Michigan Ave.,  
Chicago 60611, Ill. (312-664-5800)

**ART DIRECTOR**

Howard R. Berry (2430)

**ASSISTANT ART DIRECTOR**

John C. Wright, Jr. (3430)

**EDITORIAL ASSISTANTS**

Lorraine Rossi, Virginia T. Bastian,  
Lynn Emery, Ann Mella, Lorraine Werner,  
Alice M. O'Brien, Sharon Parks,  
Claire Benell, Kay Fontana,  
Sandra A. Le Mond, Mary Jo Jadin

**FOREIGN NEWS BUREAU**

**DIRECTOR**, John Wilhelm, (2532);  
Lawrence Mihlon (2997), Alyne Elias  
(2998)

**LONDON**—John Shinn, Derek Barlow,  
Nicholas Landon, 34 Dover St., London  
W.1, England

**BONN**—Bruce Bendow, Richard Mikton,  
Silke McQueen, Mittelstrasse 39, Bad  
Godesberg, Germany

**BRUSSELS**—27 Rue Ducarle, Brussels,  
Belgium

**PARIS**—Robert Farrell, Arthur Erikson,  
17 Ave. Matignon, 3rd Fl., Paris 8,  
France

**MILAN**—Marc A. Messina, Via Manzoni  
No. 12, Milan, Italy

**MEXICO CITY**—Wesley Perry, Jr.,  
Lafragua 4-314, Mexico 1 D.F. Mexico

**RIO DE JANEIRO**—Leslie Warren, Rua  
Mexico 3-S/1507 1509, Rio de Janeiro,  
Brazil

**MOSCOW**—Stewart Ramsey,  
Kutuzovsky Prospekt 19, Apt. 28-29,  
Moscow, USSR

**TOKYO**—Richard Halloran, Charles Cohen,  
John Yamaguchi, Toranomon Sangyo  
Bldg., 1 Kotohiracho Shiba, Minato-Ku,  
Tokyo, Japan

**CIRCULATION MANAGER**

Hugh J. Quinn (2310)

**C. C. RANDOLPH, Publisher (2016)**

DECEMBER 13, 1963

# electronics

A MCGRAW-HILL WEEKLY 75 CENTS

**NAVIGATION SIMULATOR.** Polaris submarine navigators are trained at New London and Charleston by new simulators built by Sperry Gyroscope division of Sperry Rand. Physical layout and most of the equipment duplicate systems in subs. Instructors set up problems of ocean depth, weather, position, time and even faulty equipment. Students can run through a 60-day patrol in half a day, thanks to time compression in a computer. *In the cover photo, crewman at right locks on a star through the periscope while the other two check the star chart and operate the navigation console*

COVER

**NEW COMPUTERS.** Last week, another computer manufacturer entered the low-cost business system market with a compact, high-speed model. Still another offered a new family of four medium to large computers. *A third company expanded its line with a system that gathers and analyzes data as it is generated in tests or industrial processes.*

10

**SIMULATING TACTICAL RADAR AND SONAR.** Simulators used for training, testing and war gaming need both analog and digital techniques to represent the total tactical operating environment of radar and sonar equipment. *Time compression is advantageous, realism is enhanced by providing for random fading, beam forming, range attenuation and effect of plasma wakes.*

By R. G. Hundley, General Applied Science Labs

25

**FIVE TRANSMITTERS: ONE ANTENNA.** This high-frequency multicoupler may give improved operating flexibility to point-to-point and broadcast transmitting stations. Separate and independent L-C networks, placed between each transmitter and the common load, act as a direct connection at transmitter frequency but present a high impedance at other frequencies. *Each network handles a 600-w transmitter over a decade bandwidth.*

By G. H. Barry and J. D. Hawkins, Stanford Univ.

32

**PRINCIPLES OF INJECTION LASERS.** Second article of two-part series deals with applications of injection-laser systems. The injection laser's future in communications, especially space communications, now seems assured. Possibilities for high-precision radar tracking are also bright, but much more work is needed. *Last week's article was a state-of-the-art report on injection lasers.*

By C. M. Johnson, IBM

34

Contents continued



Published weekly, with Electronics Buyers' Guide as part of the subscription, by McGraw-Hill Publishing Company, Inc. Founder: James H. McGraw (1860-1948).

Title © registered U.S. Patent Office; © copyright 1963 by McGraw-Hill Publishing Co., Inc. All rights reserved, including the right to reproduce the contents of this publication, in whole or in part.

Executive, editorial, circulation and advertising offices: McGraw-Hill Building, 330 West 42nd Street, New York, N. Y., 10036. Telephone Area Code 212 971-3333. Teletype TWX N. Y. 212-640-4646. Cable McGrawhill, N. Y. PRINTED IN ALBANY, N. Y.; second class postage paid at Albany, N. Y.

OFFICERS OF THE PUBLICATIONS DIVISION: Shelton Fisher, President; Vice Presidents: Joseph H. Allen, Operations; John R. Callahan, Editorial; Ervin E. DeGraff, Circulation; Donald C. McGraw, Jr., Advertising Sales; Angelo R. Venezian, Marketing.

OFFICERS OF THE CORPORATION: Donald C. McGraw, President; Hugh J. Kelly, Harry L. Waddell, L. Keith Goodrich, Executive Vice Presidents; John L. McGraw, Treasurer; John J. Cooke, Vice President and Secretary.

Subscriptions are solicited only from those actively engaged in the field of the publication. Position and company connection must be indicated on orders. Subscription rates: United States and Possessions and Canada, \$6.00 one year, \$9.00 two years, \$12.00 three years. All other countries \$20.00 one year. Single copies, United States and Possessions and Canada 75¢. Single copies all other countries \$1.50.

THE PUBLISHER, UPON WRITTEN REQUEST TO OUR NEW YORK OFFICE FROM ANY SUBSCRIBER, AGREES TO REFUND THAT PART OF THE SUBSCRIPTION PRICE APPLYING TO COPIES NOT YET MAILED.

Subscribers: Please send change of address notices, subscription orders or complaints to Fulfillment Manager, Electronics, at the address below. Change of address notices should provide old as well as new address, including postal zone number if any. If possible, attach address label from recent issue. Allow one month for change to become effective.

Postmaster: Please send Form 3579 to Fulfillment Manager, Electronics, P. O. Box 430, Hightstown, New Jersey, 08520.



Audited Paid Circulation

Contents continued

**INTEGRATED-CIRCUIT OSCILLATOR.** This monolithic silicon diffused structure comprises a transistor and a distributed R-C transmission line as a phase shifter. It fits onto a TO-5 header; construction is efficient—resistor diffusion or interconnection is not needed because resistors are formed using the transistor collector's bulk resistance. *The unit can oscillate at around 1 Mc with a 1-v output; f-m applications may be possible.*  
By H. Yanai, T. Sugano and M. Yoshida, Tokyo Univ.  
T. Kurosawa and I. Sasaki, Nippon Electric Co. 40

**LASER AMPLIFIER.** Input-power requirement for laser-beam amplifier is cut to few watts by using neodymium-doped rod. Feedback configuration may raise total output into the kilowatt range. *Development is aimed at laser surveillance systems* 42

**FREQUENCY-TUNABLE LASER.** Here's what those miniature gas lasers look like. *They can be tuned, or operated as swept-frequency oscillator by moving end mirrors with piezoelectric crystal* 42

**NUCLEAR INSTRUMENTS.** Reports on nanosecond instrumentation indicate that picosecond nuclear equipment is just around the corner. *Tunnel diodes are going into some of the faster analyzers* 43

DEPARTMENTS

Comment. Microwaves and Concrete. Data	6
Electronics Newsletter. NASA Buying Laser Communications System, May Use It in Gemini Flights	17
Meetings Ahead. Electromagnetic Compatibility National Symposium	18
Washington This Week. Military To Spend More on Basic Research	20
Research and Development. Chemicals Affect Oscillator Output	46
Components and Materials. Built-In Diodes Protect Nickel-Cadmium Cells	50
Production Techniques. Wetting Agent Solves Photo-etching Problem	54
New Products. Tape Punch Has Electronic Keyboard	58
Literature of the Week	62
People and Plants. Space Center Opens	64
Index to Advertisers	70





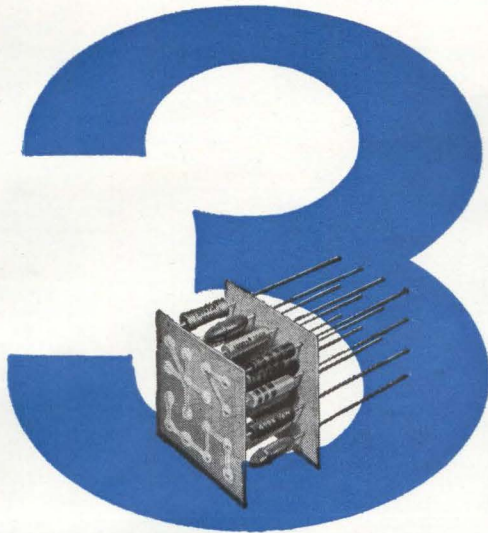







# All from Sprague...for "cordwood" packaging!



## ULTRA-MINIATURE SOLID TANTALUM CAPACITORS

...PLUS...

 <p><b>TYPE 206P</b> Epoxy-Coated <b>PACER®</b> polyester film <b>CAPACITORS</b> Engineering Bulletin 2067</p>	 <p><b>TYPE 252C</b> Molded-Case <b>CERA-MITE®</b> ceramic <b>CAPACITORS</b> Engineering Bulletin 6151</p>	 <p><b>TYPE 262C, 263C</b> Molded-Case <b>MONOLYTHIC®</b> layer-built ceramic <b>CAPACITORS</b> Engineering Bulletin 6250</p>	 <p><b>TYPE 903Z</b> Epoxy-Coated <b>INDISTOR®</b> induction-resistance <b>DELAY NETWORKS</b> Engineering Bulletin 45,001 <small>*Trademark</small></p>	 <p><b>TYPE 416E, 418E</b> Molded-Case <b>FILMISTOR®</b> metal film <b>RESISTORS</b> Engineering Bulletin 7025B</p>
 <p><b>TYPE 405E, 411E</b> Molded-Case <b>FILMISTOR®</b> deposited-carbon <b>RESISTORS</b> Engineering Bulletin 7000B</p>	 <p><b>TYPE 239E</b> Vitreous-Enamel <b>BLUE JACKET®</b> power wirewound <b>RESISTORS</b> Engineering Bulletin 7410D</p>	 <p><b>TYPE 219E</b> Silicone-Encapsulated <b>ACRASIL®</b> precision power wirewound <b>RESISTORS</b> Engineering Bulletin 7450</p>	 <p><b>TYPE 5000Z</b> <b>CONNECTORS</b> and <b>ISOLATORS</b> ("shorts and opens") Engineering Bulletin 94,000</p>	 <p><b>TYPE 7000Z</b> Shielded Radio Frequency <b>INDUCTORS</b> Engineering Bulletin 41,800</p>

The Sprague components shown here are available in the two basic sizes (.090"D. x .250"L. and .138"D. x .390"L.) you need for the accepted high-density technique known as "cordwood" packaging. If you wish, they can be furnished on lead tape for automatic insertion on printed wiring boards. And with standardized sizes, these components can be installed with the same machines, permitting more efficient use of insertion equipment.

For complete technical data, write for Engineering Bulletins listed above. Address: Technical Literature Service, Sprague Electric Company, 35 Marshall Street, North Adams, Massachusetts.

### SPRAGUE COMPONENTS

CAPACITORS  
TRANSISTORS  
RESISTORS  
MICROCIRCUITS  
INTERFERENCE FILTERS

PULSE TRANSFORMERS  
PIEZOELECTRIC CERAMICS  
PULSE-FORMING NETWORKS  
TOROIDAL INDUCTORS  
ELECTRIC WAVE FILTERS

CERAMIC-BASE PRINTED NETWORKS  
PACKAGED COMPONENT ASSEMBLIES  
BOBBIN and TAPE WOUND MAGNETIC CORES  
SILICON RECTIFIER GATE CONTROLS  
FUNCTIONAL DIGITAL CIRCUITS

49C-139-63



\*Sprague' and '®' are registered trademarks of the Sprague Electric Co.



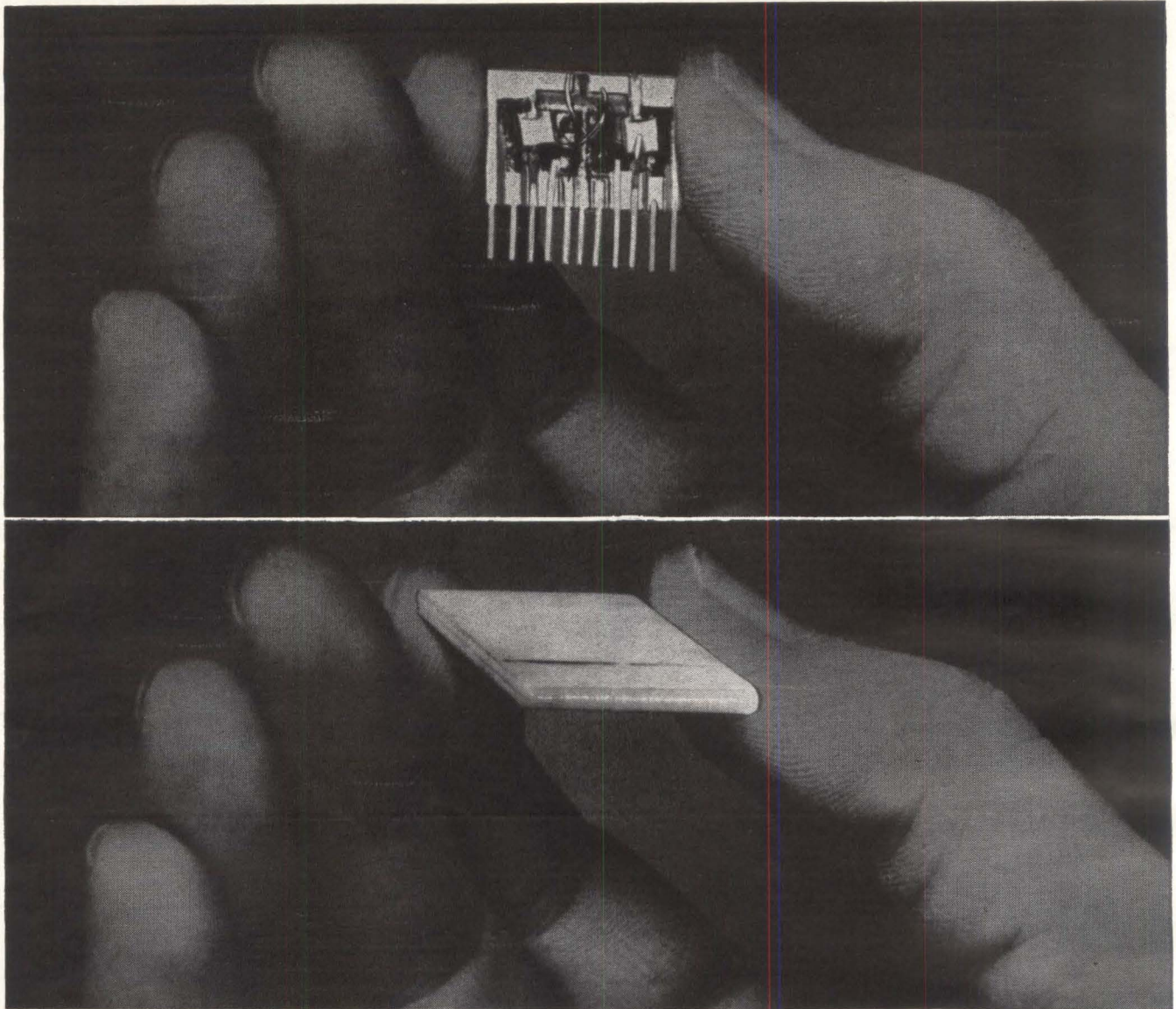

Micro-electronic welds to nickel-plated ceramic substrate (top) and two edge-welded aluminum oxide ceramic wafers (bottom) show versatility of Hamilton-Zeiss Welders.

## ELECTRON BEAM WELDING . . . a new world of design at your fingertips

Hamilton-Zeiss Electron Beam Welders produce ultra-precise microminiature welds which set new standards of connection reliability. They also permit fabrication with difficult-to-join materials such as ceramics, refractories, and titanium. The Hamilton-Zeiss process allows designers of micro-electronic circuits and components to achieve optimum packaging density, reduced weight, and increased reliability.

The three exclusive Hamilton-Zeiss features which make these advantages possible are:

- Small beam diameter with high power density (37½ million watts per square inch).

- Optical viewing system which shows exact position of the beam on the workpiece at all times (40 mag.).
- Precise, repeatable control of beam energy, position, and penetration.

The process also permits component encapsulation and contamination-free joints of high structural integrity because the work is performed in a vacuum.

For full technical data on Hamilton-Zeiss Electron Beam Welder, write or wire: Electron Beam Systems, Hamilton Standard Division, United Aircraft Corporation, Windsor Locks, Connecticut.

**Hamilton Standard** DIVISION OF UNITED AIRCRAFT CORPORATION

**U  
A**





## Where do the big birds fly?

To the big cities! To New York, Los Angeles, Chicago, Detroit, Boston, San Francisco, Portland, Seattle, Cleveland, Binghamton, and Hartford. The big cities. The major markets.

Flying Tigers reach another 2,500 markets around the country via Skyroad. Combining air, rail and truck transportation, Skyroad moves your shipment quickly on one bill of lading, and at a single through rate.

Tigers' Swingtail-44 is the big one.

With a cargo hold 84' long and 6'9" high, it can handle outside cargo others can't. And it holds a lot—everything on the dock. No waiting for your shipment to go out.

Minimum shipments have an added advantage, for Tigers' minimum rates are lower—about half of what most other airfreight carriers charge.

So whatever the size of the shipment, whatever the size of the destination point... go big. Go Tigers. Among all-cargo airlines, it's the biggest.

*first in airfreight with airfreight first* **FLYING TIGER LINE**





**Only from Sprague!**

# DOUBLE FEATURE!

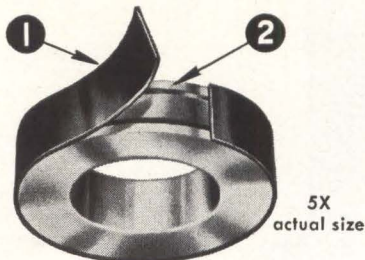

**Dynacor® Bobbin Cores have 2 built-in reasons for long operating life without degradation...**

**1 TOUGH ARMAG® JACKET.** Withstands ambient temperatures to 180 C and is compatible with poured potting compounds, permitting Dynacor Cores to be used with normal encapsulation techniques.

**2 JET-SMOOTH BOBBIN.** Finely-polished stainless steel, completely eliminating sharp protrusions, square corners, or other abrasive action on copper wire windings. Improved manufacturing process results in a bobbin with a more uniform radius than that of an ordinary machined bobbin.

Dynacor Bobbin Cores are also available with ceramic bobbins where needed.

A large stock of popular sizes and flux values insures prompt delivery.

Special cores to customer specifications are quickly and accurately processed.

**For complete technical data, write for Engineering Bulletins on Dynacor Bobbin Cores to Technical Literature Service, Sprague Electric Company, 35 Marshall St., North Adams, Mass.**



® Sprague and ® are registered trademarks of the Sprague Electric Co.

45SP-170-63

## COMMENT

### MICROWAVES AND CONCRETE

Have just read your item on British experiments with microwaves in cracking concrete (p 38, Nov 29). Even when used on reinforced concrete, the microwaves caused explosions "that separated the concrete from reinforcing rods."

This sounds like exactly what is needed to break up the numerous, huge World War II concrete bunkers and the many miles of "dragon's teeth" tank traps that dot Europe's countryside. Explosives are too expensive for the job, and so these concrete monsters have been in place for 20 years. If such a microwave generator could be mounted on a truck, many acres of land might be restored to peaceful uses.

New York, New York

### SATURN V INSTRUMENTATION

Your article about the Saturn V instrumentation, New Twist in Space Tracking: The Vehicle Tracks the Ground (p 10, Nov. 15), included specifications and manufacturer's names for the tracking systems, and although you included the types of telemetry systems to fly on-board Saturn, you neglected to mention the frequencies or the manufacturers for these. Could you list these frequencies, and possibly give more details on the telemetry?

I. GALLANT

Brooklyn, New York

• Further information on the telemetry was not supplied because it was not available. Specific pieces of telemetry equipment have not been specified and contracts have not yet been awarded. Specs and manufacturers were included for the tracking gear, only as it applies to Saturn I and IB.

### DATA

I can no longer remain silent!

For some years you have allowed the word *data* to be used in articles in the singular sense, despite the fact that *data* is the plural of *datum*.

On p 26 of the Nov. 29 number, the first sentence of the third paragraph reads, "Data in the store is in 6-bit words . . ." This shook my grammatic sensibilities more than usual. The sentence should be, "Data in the store are in 6-bit words . . ."

LLOYD E. VARDEN  
Professor of Graphics

School of Engineering  
Columbia University  
New York, New York

• Our editors generally consider data as plural when referring to several classes of data, as in "These data on X, Y and Z are . . ." However, we generally prefer the singular when referring to a body or collection of data, as in "The (total of) data in the memory is . . ."

Webster's International Dictionary seems to give us this option: "Although plural in form, *data* is not infrequently used as a singular; as, this *data* has been furnished for study and decision." By the way, does anybody ever say "Our datum is . . .?"

### CORRECT PARENT

In your Aug. 2 article, Microelectronics Around The World, you state on p 41 that "Grundig owns the Olympia company, one of West Germany's largest office machine manufacturers."

I should like to bring to your attention that this is not correct. The Olympia-Werke in Wilhelmshaven is a 100-percent subsidiary of AEG. To the Grundig group belongs the oldest German typewriter factory, the Adler-Werke AG, Frankfurt/Main, as well as the Triumph-Werke Nürnberg AG, likewise an office-machine factory with a very long tradition. Both factories together have a significant share of the market for typewriters and business machines. The shares of the Triumph-Werke AG are almost entirely, and those of the Adler-Werke, 80 percent, in the possession of the Grundig group.

REICHEL

Grundig Werke GmbH  
Fürth/Bay., West Germany



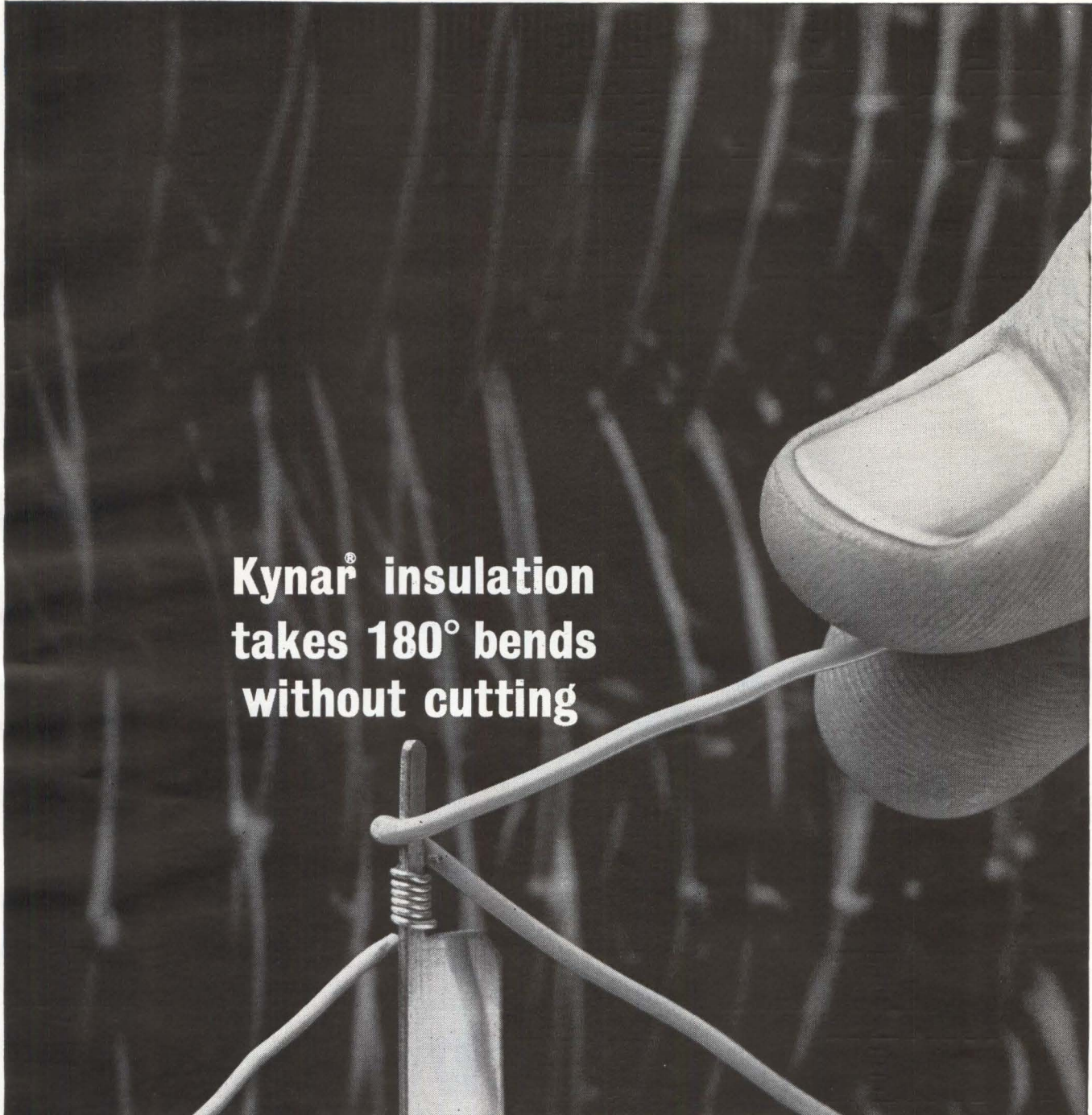

**Kynar<sup>®</sup> insulation  
takes 180° bends  
without cutting**

Now you can pull computer hookup wire around tight corners—even stretch it over sharp edges—without danger of insulation cutting through. The secret: Kynar, Pennsalt's vinylidene fluoride resin, a new high-performance fluoroplastic that's *tough!* □ Wire insulation of Kynar offers unmatched mechanical strength and toughness, even in 5-mil sections you may need for miniaturization. It cuts cleanly, strips readily,

won't burn or melt. Dimensionally stable, Kynar doesn't stretch when wires are pulled. Wire insulated with Kynar has ample stiffness yet stays in place when harness is bent to shape. □ Write for our brochure and the names of leading manufacturers who supply wire insulated with Kynar. Plastics Department, PENNSALT CHEMICALS CORPORATION, 3 Penn Center, Philadelphia 2, Pa.

***Kynar...a fluoroplastic that's tough!***

*Kynar is a Registered Trademark of Pennsalt Chemicals Corp.*





# ONLY NEW GEN-PRO 700 SERIES INDUSTRIAL TERMINAL BOARDS **ARE** **PRE-PACKED IN EVERY POSSIBLE** **SIZE AND VARIATION...**

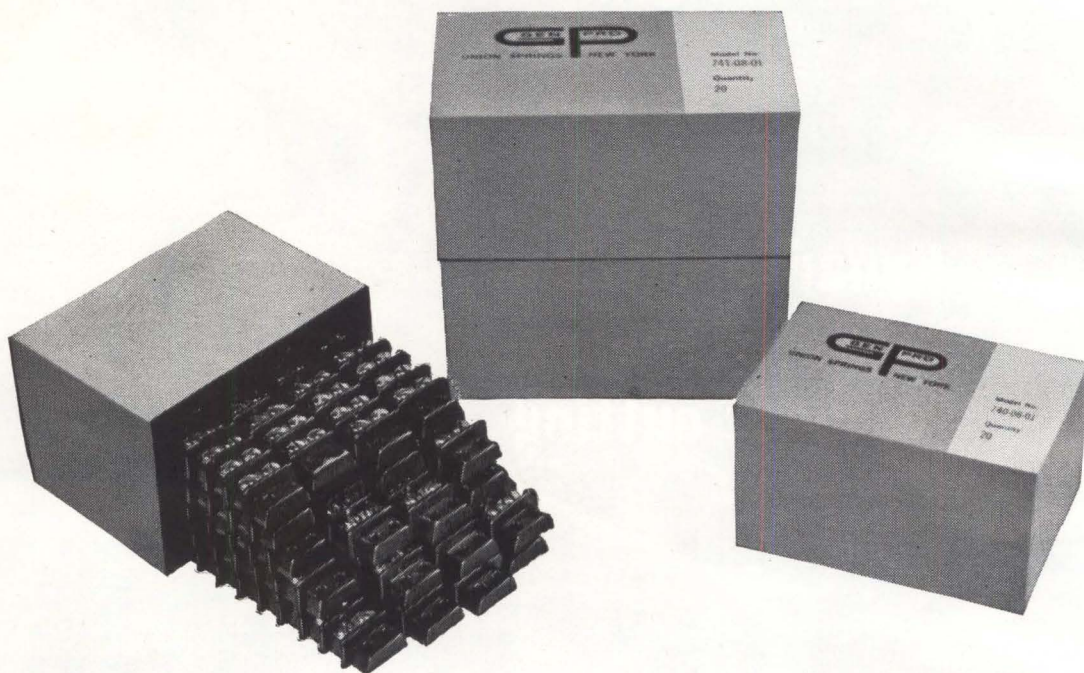

## **YOU GET EXACTLY WHAT YOU WANT** **... WHEN YOU WANT IT**

You can count on Gen-Pro's new 700 terminal boards for the reliability you want for any application—and on Gen-Pro's unique pre-packaging and "timed" delivery program to keep production humming. All sizes—all variations in number of

stations—are packaged in lots of 5, 10 and 20. The boards of your choice are shipped from stock in the quantities you require—when you need them. Back orders are virtually non-existent. Write to Dept. SMMD today for illustrated literature.

### 700 SERIES TERMINAL BOARDS

Model No.	Voltage, RMS	Terminals
740	1200	1-46
741	1600	1-39
742	2500	1-30
764*	1600	1-46

\*6/32 screws



**GENERAL PRODUCTS CORPORATION ■ UNION SPRINGS, N.Y.**

Phone: (area code 315) TT9-7367 • TWX: 315-999-1455



# Burroughs Corporation

ELECTRONIC COMPONENTS DIVISION

# ANNOUNCES

THE FORMATION OF A NEW

# DISPLAY SYSTEMS GROUP

We're ready to design and build the readout system that will solve your display problems.

With the introduction of the new Alpha-Numeric Nixie® Tube, Burroughs has established a design group to provide complete alpha-numeric display systems utilizing this unique product. Examples of electronic information readout systems which we are prepared to produce for you include: • military tactical situation displays • airline arrival and departure boards • industrial control displays. The new group includes readout designers, circuit and systems designers and packaging specialists. They are prepared to help you now.

Write or phone Jack Murphy, Plainfield 7-5000 (area code 201).



ANOTHER ELECTRONIC CONTRIBUTION BY  
**Burroughs Corporation**  
ELECTRONIC COMPONENTS DIVISION  
PLAINFIELD, NEW JERSEY





# Six More Computers

Five sharpen competition  
for the usual markets;  
sixth gathers data, too

By **STEPHEN B. GRAY**  
Assistant Editor

**NEW YORK**—Competition in the computer business has been sharpened by a flurry of new computer introductions:

- Honeywell brought out its H-200, the company's first compact, low-cost business system, intended to compete with IBM's 1400 series in the small computer market.

- General Electric announced a family of four business and scientific computers, the 400 series, aimed at the other half of the computer market.

- IBM came up with a new type of system, the 7700, which acquires test or process data and analyzes the data as acquired.

Honeywell said small computers are the fastest-growing segment of the computer market, and estimated potential sales at \$1.6 billion for replacement of the 7,500 now installed.

GE also reported that it may add a small computer to the 400 series and that it plans to broaden its peripheral equipment line. GE figures peripheral equipment now averages about 60 percent of hardware value.

To quiet rumors that it would introduce two new large-scale scientific computers this month, GE said they would not announce them this year. These are the 625 and 635, known inside GE as the Q-2.

**Small Computer**—The H-200 will be marketed to new users, or as a satellite computer, or as a replacement for current small machines.

Initial production models will go on tour in March, into new Honeywell service centers at New York and Los Angeles in April, and to customers starting next July. A minimum system will rent for \$3,160 a month and sell for \$140,000.

A 3-pass conversion routine,

boldly named "Liberator," converts programs written for the IBM 1401, 1440 and 1460 computers into H-200 programs. Honeywell claims these programs will run as fast, or faster, in the H-200 as in the original.

The H-200 main memory is expandable to 32,768 characters and has a 2- $\mu$ sec cycle time. The control or "scratch-pad" memory, with a 500-nsec cycle time, contains up to 16 storage registers. A traffic-control unit permits simultaneous operation of data processing, printing, punching and tape-data transfer.

**Family of Four**—GE's 425, 435, 455 and 465 are medium and large systems. The last two have floating-point capability for scientific applications.

The family is upward-compatible, with each successive computer providing 80-percent-greater processor performance. The central processors are directly interchangeable, so one system can be converted to another "over the weekend." The 400's are not compatible with GE's 200's, except by magnetic-tape; communication between the two will be possible with Datanet equipment.

The GE-425 has a memory cycle of 5.1  $\mu$ sec; the 435, 2.7  $\mu$ sec. Memory access time of the 455 is 2  $\mu$ sec per word; the 465 halves that. A thin-film memory, operating at 0.5  $\mu$ sec per word, is optional on the 455 and 465. All four computers have conventional core memories ranging up to 131,072 characters.

One of the first 400 systems will be delivered to Western Pacific Railroad, for real-time maintenance of files on rolling stock, manpower and waybills.

Rental rates range from \$5,800 to over \$30,000 monthly; sales prices, from \$270,000 to over \$1.5 million. Orders are being taken on the 425 (7 months delivery) and 435 (11 months); the two larger systems will be available in mid-1965.

**Data Analyzer**—The IBM 7700 data acquisition system, with a 2- $\mu$ sec memory cycle time, can collect

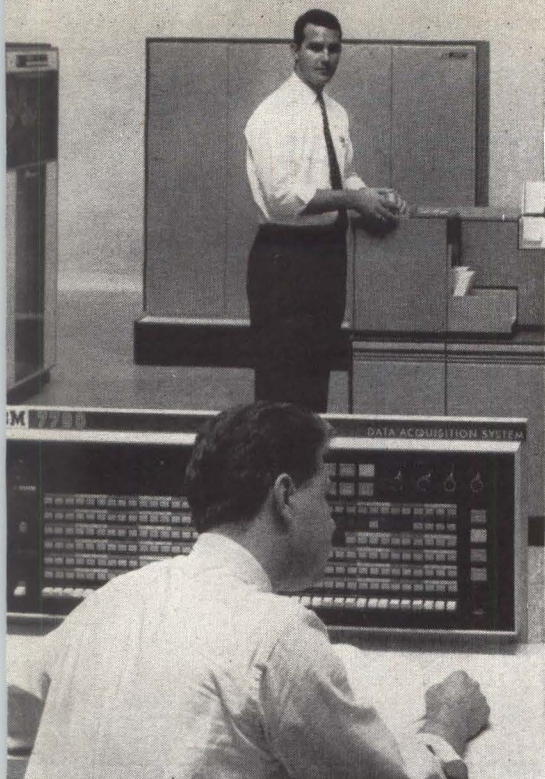

**MAKING THEIR DEBUT.** IBM 7700 (top) gathers data from up to 32 sources. Honeywell H-200 (center) provides working space on top of 42-inch main frame. X and Y shapes of GE series (425 is shown, bottom) shorten wire lengths and thus increase speed





# Announced

data from 32 sources simultaneously, process them and transmit results to as many as 16 remote printers, display units or plot boards. It was designed to handle the flood of data from operations such as space flight, jet-engine testing, and industrial process monitoring.

Within its central processor, which combines an arithmetic and control unit, the 7700 has a 48-subchannel multiplexer to control the receiving and transfer of data between the processor and all remote devices. The 48 subchannels together can handle up to 9 million bits a second.

The basic 7700 system, including 16,384 words of core storage, rents for \$6,700 a month, sells for \$269,000. Deliveries are scheduled for the third quarter of 1964.

## Subroc Passes Test



NAVY is building 25 nuclear attack submarines to carry the new Subroc nuclear depth bomb, shown here being loaded aboard the **USS Permit**. Ship's sonar feeds target data to fire-control system. Subroc is launched underwater from torpedo tubes, surfaces and becomes airborne, then drops warhead near enemy submarine. Goodyear Aerospace is prime contractor. General Precision supplies fire control and most of the guidance

## "THIS BETTER BE GOOD!"....

... I wouldn't have taken the time, if Standards hadn't sent you. As I understand it, you sold them an oscillator, which they think can help *me!* Did they fill you in?

*Yes — they tell me the final test on your new line of amplifiers seems to be chewing up a lot more time than you'd like.*

Time? Please! Every time the brass walks through here and sees those unshipped instruments, I get visions of my merit file being stuffed with nasty little notes! Big problem's been in checking for frequency response and harmonic distortion. Just too bloody long on each instrument!

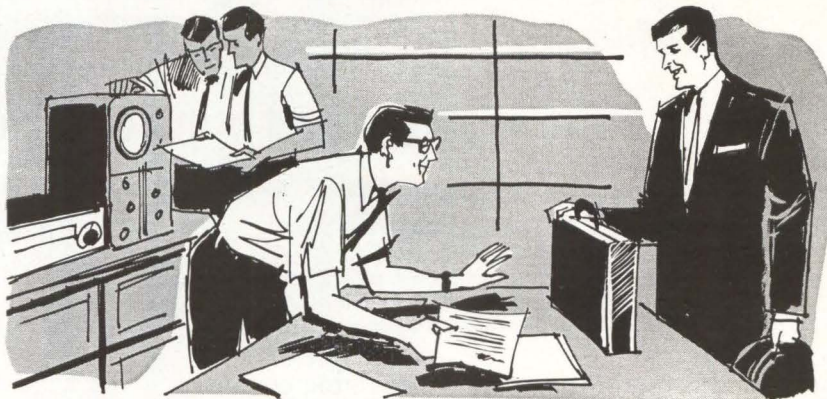

*Take the tests one at a time. Frequency response. Been feeding preset amplitudes at frequency steps, reading amplifier output and comparing? Have to go back to the signal source each time to check and reset its output amplitude at every frequency?*

Sure! Otherwise, I've got oscillator amplitude error in my gain figure.

*OK. You don't have to. The frequency response of the Krohn-Hite 446 oscillator is within 0.01 db up to 20 kc, within 0.05 db all the way from 10 cps to 100 kc. And short-term amplitude stability of 0.01%! So, forget about resetting voltage every time you change frequency.*

Beautiful! Eliminating rechecking the source and re-setting will *really* speed things up.

*Now — what are you doing to the input signal when you measure harmonic distortion of the amplifier? Have to purify the oscillator output?*

Naturally!

*Not at all . . . use the 446 as your source and forget about harmonic distortion — it's less than 0.02% from 400 cps to 5 kc, and only 0.2% at 20 cps and 20 kc. Another thing — the 446 is available fully programmable for automatic check-out — including self-checking, "enable" and "completed" circuits.*

Brother — you've just saved me 8 hours an instrument! I'm going upstairs right now and pinch a 446. We can ship some amplifiers tonight!

*Hold it! They're right in the middle of DVM calibrations with their 446's. But I'll let you buy your own from me.*

Dammit, progress always costs!



**KROHN-HITE  
CORPORATION**

580 Massachusetts Avenue, Cambridge 39, Mass.  
Area Code 617 491-3211

*Pioneering in Quality Electronic Instruments*



# MAXIMUM RELIABILITY



Provided by photochopper in this completely solid state  
**DC AMPLIFIER**  
for only \$395!

**Photoconductive chopper, all-transistor circuitry permit reliable low-level measurements with the wide-band, high-gain DY-2460A.**

Here's a completely solid state high-gain DC amplifier for only \$395. Exceptional reliability is achieved on low-level measurements with a specially designed photoconductive chopper and all-transistor circuitry.

The DY-2460A will supply an output of  $\pm 10$  v peak at 10 ma. Zero drift is less than  $1 \mu\text{v}$  per week, noise less than  $4 \mu\text{v}$  peak to peak. Fast settling time (as little as  $25 \mu\text{s}$  to 0.01%) and rapid overload recovery (only  $20 \mu\text{s}$ , plus settling time) make the amplifier ideal for systems use.

Long life is assured for the DY-2460A because of advanced solid state design. The photo chopper is unaffected by external vibration and is inherently a long-life device. Power consumption is only 4 watts, so that heat problems are non-existent.

Plug-in versatility is offered in the DY-2460A, with interchangeable plug-ins available for systems use (5 fixed gains, 10 to 1000); bench use (fixed gain in decade steps 1 through 1000); for special individual situations (patch panel brings input, output, summing point and feedback circuit to the front panel), and plus-one amplifier uses (input resistance greater than  $10^{10}$  ohm, high gain accuracy).

**PRICE:** DY-2460A Amplifier, \$395.00. DY-2461A-M1 Data Systems Plug-in, \$85.00. DY-2461A-M2 Bench-use Plug-in, \$125.00. DY-2461A-M3 Patch Unit Plug-in, \$75.00. DY-2461A-M4 Plus-one Gain Plug-in, \$35.00.

Write or call today for complete details and specifications.  
*Data subject to change without notice. Prices f.o.b. factory.*

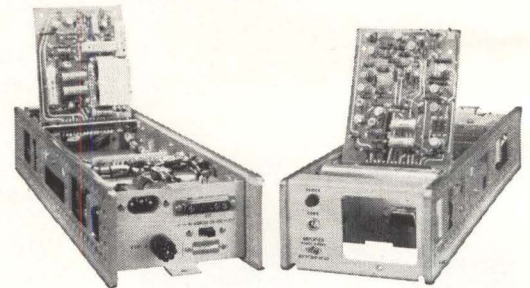

Major circuits of the DY-2460A are mounted on three plug-in etched circuit boards, which swing out for easy access. Sides, top and bottom are easily removed for servicing.

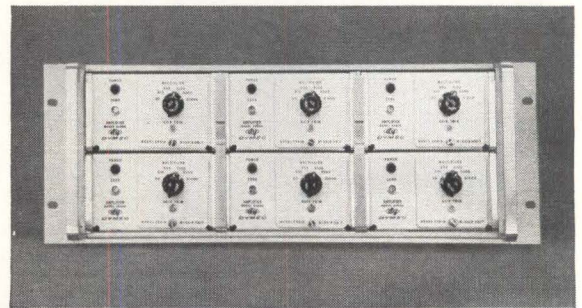

A combining case accommodates up to six amplifiers, can be used on the bench or mounted in standard rack with adapters furnished. Combining case C-146B-2, \$200.00.

## DYMEC

A Division of Hewlett-Packard Company

Dept. E-12, 395 Page Mill Road, Palo Alto, Calif. Tel. (415) 326-1755 • TWX, 415-492-9363





NUMBER ONE IN ELECTRICAL CONNECTORS...



What is your  
Coax problem?

ELECTRICAL  
ENVIRONMENTAL  
MECHANICAL

ASK  
CANNON®  
FOR  
THE  
ANSWER

**ELECTRICAL?** VSWR, Hi Voltage, RFI, Signal to Noise Ratio, Insertion Loss, Broadband Performance, Matched Phasing, Impedance Transformation. **ENVIRONMENTAL?** Weatherproof, Altitude, Hermetic, Radiation Resistant, Pressurized, Salt Spray, Hi Temperature, Direct Burial, Waterproof. **MECHANICAL?** Lightweight, Blind Coupling,

Push-On, Bayonet, Screw Coupling, Rack & Panel, Non-Standard Cables, Cable Retention, Captive Contacts. We have solved problems in all of these areas plus many more! If you have a Coax problem, or any other connector problem, consult CANNON, the world's largest and most experienced manufacturer of electrical connectors. Write:

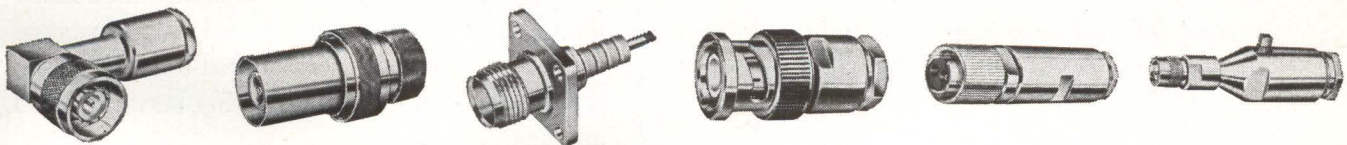

® "CANNON" IS A TRADEMARK REGISTERED IN U.S. PAT. OFF. AND IN OTHER COUNTRIES BY CANNON ELECTRIC COMPANY



CANNON ELECTRIC INC.

3208 Humboldt Street, Los Angeles 31, California



A SUBSIDIARY OF INTERNATIONAL TELEPHONE AND TELEGRAPH CORPORATION

©1963 CANNON ELECTRIC COMPANY



# Business Aid To Education: Let's Broaden The Base

The total amount of financial support that American business corporations are giving to our colleges and universities is increasing rather impressively. But the number of companies contributing to this expansion is woefully small. If business support of higher education is to attain the proportions it clearly should attain, there must be a large increase in the number of companies participating — and soon.

The Council for Financial Aid to Education estimates that business firms contributed about \$200 million to education last year. This was up from a total of about \$178 million in 1960; and preliminary indications are that business-giving will exceed \$200 million this year. As a total, this is a relatively impressive figure. It becomes more impressive when viewed against the fact that it will be about two and one half times as much as business firms were giving to education ten years ago.

## A Flaw In The Picture

But there is a grave flaw in this picture of business-giving to higher education. The giving is concentrated in relatively few business firms that provide large sums, while hundreds of thousands of firms do little or nothing at all. Of the \$200 million contributed to education by business in 1962, the Council for Financial Aid to Education found that about \$70 million, or more than a third of the total, came from only 150 companies, each of which contributed more than \$100,000. In fact, increased giving by large corporate contributors accounted for most of the total increase in corporate giving between 1960 and 1962.

There are no figures comprehensive enough to determine precisely how many business firms contribute to the support of higher education in the United States. But studies indicate that virtually all of this aid comes from less than one per cent of U.S. business establishments.



## Unused Capacity For Business Giving

At the present time, there are more than four and three quarters million business establishments in the U.S. A great many of them, of course, are one-man establishments which are not able to help higher education financially. But there are tens of thousands of others which have unused capacity to help.

Inquiries by the Council for Financial Aid to Education indicate that almost half of the nation's 500 largest industrial corporations have no programs to help our colleges and universities financially. With combined profits after taxes of almost \$2 billion in 1961, these firms represent an imposing, untapped potential for help. And so do tens of thousands of smaller companies. Their gifts would be smaller, but their numbers would compensate for necessarily smaller amounts by coming in much larger numbers.

The Council for Financial Aid to Education has set a goal of \$500 million for annual corporate aid to our colleges and universities by 1970. Very conservatively estimated, the total expenditure for higher education at that time promises to be \$9 billion to \$11 billion a year. This makes \$500 million a relatively modest share in the support of educational operations so vital to the welfare of the nation and the business community.

## Needed— A Much Broader Base

But if this goal is to be reached, the base of corporate support must be broadened. This means more and more effective work by the colleges and universities in seeking support from smaller companies. It means more readiness by more firms to listen with understanding and sympathy, and then to use their capacity to give financial support accordingly.

Viewed narrowly, it is in the selfish interest of business firms to help our colleges and universities financially. By doing so, they give essential

support to basic research, centered in the universities, upon which the business system depends heavily for the opening of new scientific frontiers. Financial support for higher education also helps to insure a continuing supply of well trained graduates which business firms must have to insure their own continuing success.

By making it tax exempt, the federal government, in effect, assumes half of the cost of financial aid for higher education by business. But this fiscal fact does not detract from both gratitude and respect which business firms can win for themselves by providing such aid. And in the last analysis, if financial aid is not provided voluntarily, it can confidently be expected that business will ultimately provide much of it involuntarily, through taxation.

Viewed in terms of the broad public interest, the business community has an opportunity to play a key role in providing our colleges and universities with the financial strength essential to assurance of their successful development which, in turn, is basic to the success of the nation.

**There are few, if any, financial operations that can pay larger returns in advancing the national interest, as well as the more immediate interest of the business community, than that of seeing our colleges and universities receive steadily increasing financial support from more and more business firms.**

This message was prepared by my staff associates as part of our company-wide effort to report on major new developments in American business and industry. Permission is freely extended to newspapers, groups or individuals to quote or reprint all or part of the text.

*Donald C. McGraw*

PRESIDENT

**McGraw-Hill Publishing Company**



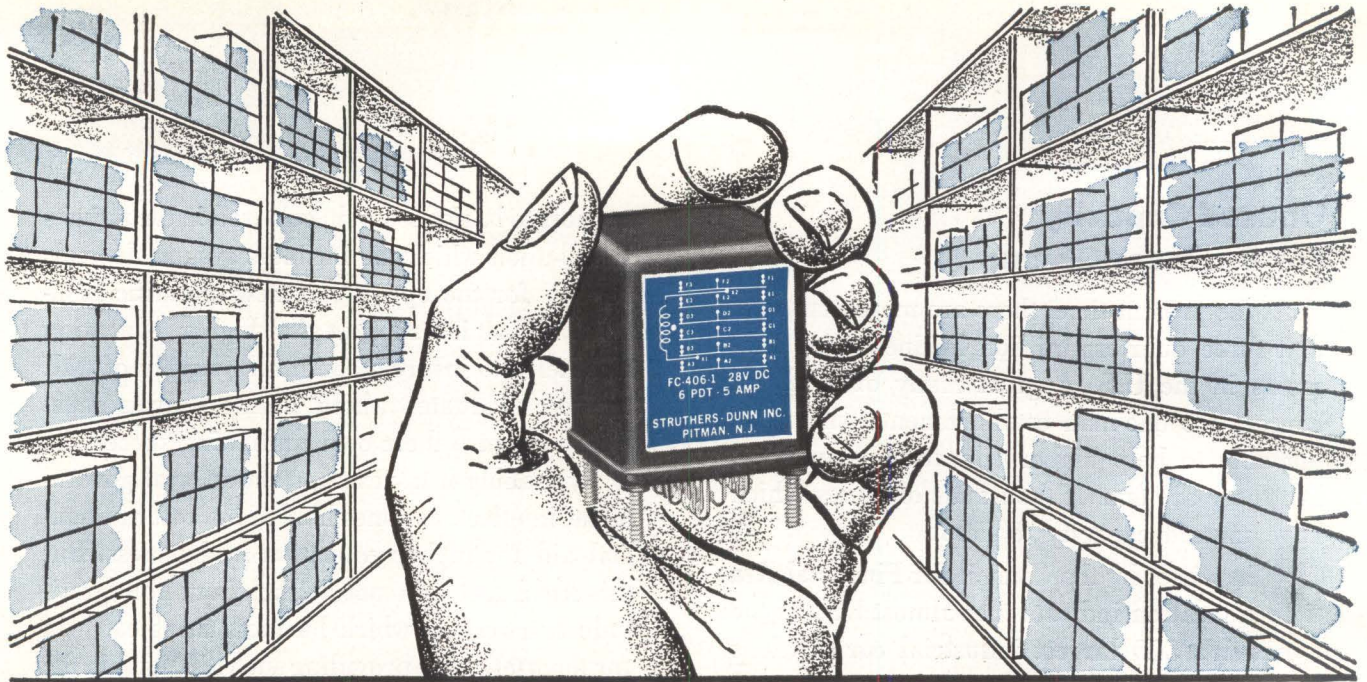

# IN STOCK at Your Distributor's

Dunco 4 & 6 pole  
balanced armature  
**Air Frame Relays**  
...to MIL-R-6106C

No waiting.

Your Struthers-Dunn stocking distributor has a complete stock of these Dunco Air Frame Relays.

The FC-400 — a 10-ampere, 4-pole double throw relay.

And the FC-406 — a 5-ampere, 6-pole double throw relay.

He has them both in 28 volt d-c, or 115 volt 400 cycle a-c models. And with plug-in or hook-type solder terminals.

For long life and exceptional reliability, we manufacture with non-gassing materials, clean often as assembly progresses, then hermetically seal each relay before it's permitted to leave the white room.

Standard models — to MS-25269-A1 and -D1; MS-25271-A1 and -D1; MS-25327-A1 and -D1; and MS-25329-A1 and -D1 — are available now.

For relays, see your distributor. For specifications and name of your nearest distributor, write Struthers-Dunn, Inc., Pitman, New Jersey.

## STRUTHERS-DUNN, Inc.

PIONEERS IN SPACE AGE RELAY RELIABILITY

*Member, National Association of Relay Manufacturers*



SALES ENGINEERING OFFICES IN: Atlanta • Boston • Buffalo • Charlotte • Cincinnati • Cleveland • Dallas • Dayton • Encino • Englewood • Houston • Kansas City • Las Vegas • Memphis • Newark • New York • Orlando • Pittsburgh • St. Louis • Salt Lake City • San Antonio • San Diego • San Mateo • Scottsdale • Seattle • Southfield • Wichita • Wilmette. Canadian Licensee: Renfrew Electric Co., Ltd., Toronto. Export Department: 1505 Race St., Philadelphia 2, Pa., U.S.A.



# NASA Orders Laser-Link Hardware

HOUSTON—NASA's Manned Spacecraft Center has given IBM a \$83,515 contract to build a "highly simplified" experimental injection-laser communications system. NASA says it is "possible" that the system will be used on Gemini (p 52, June 14), but that it doesn't foresee this now.

The contract calls for testing of basic optical communications technology and atmospheric effects on coherent beams for evaluation for future deep-space missions. Point-to-point ground communications will be tested first, then aircraft-to-ground. The work is being carried out at Washington Systems Center in Bethesda, Md.

In the airborne transmitter, IBM will employ a gallium-arsenide injection laser that can function near room temperatures.

The operator will manually aim the transmitter at a pulse-laser beacon source located at the ground receiver and speak into a helmet microphone. The ground receiver will detect the narrow, voice-modulated beam and demodulate it.

IBM has been working on communications applications for injection lasers for some time (see detailed articles p 61, Dec. 6, and p 34, this week's issue).

## Apollo Slowdown

WASHINGTON — NASA has ordered a hold-down on spending. The agency has told contractors for Apollo, which accounts for 75 percent of NASA's fiscal 1964 budget, to stop all hirings for the time being. NASA is afraid it will exceed the \$5.1 billion that Congress finally approved. NASA had requested a budget of \$5.7 billion. Contractors and their major subcontractors will be sharply held down on expenditures until NASA has reprogrammed its work to fit the \$5.1 billion budget. Hopefully, the agency says, this should be accomplished by the end of the year.

## McNamara Kills Dynasoar

WASHINGTON—Secretary of Defense McNamara has cancelled the Air Force's one-man Dynasoar manned space program. But, the service has been given the okay to develop a near-earth Manned Orbiting Laboratory. The change in programs will save about \$100 million over the next 18 months.

Dynasoar has cost close to \$400 million so far, and would have run close to \$1 billion to finally develop. Although McNamara would not say at this time just how much the new MOL program will cost, he put it at "hundreds of millions."

The new MOL program will use a modified Gemini spacecraft—Gemini-X—to ferry a pressurized station into orbit. Astronauts will transfer into the station for periods up to a month, then reenter the Gemini-X for return to earth.

A tentative schedule calls for launching the first unmanned Gemini-X in the first half of 1966; a manned launch in the second half of 1966; first unmanned lab launch in late 1967 with a manned lab flight in the first half of 1968.

## Chemically Pumped Lasers Pass Feasibility Tests

ARMY's Picatinny Arsenal has successfully completed a feasibility study of chemically pumped lasers using pyrotechnic reactions. Laser action was achieved with neodymium-doped-glass lasers, calcium tungstate and ruby crystal, with ruby showing the highest temperature threshold. Present research is aimed at optimizing the formulation to trigger the laser without damaging it by pressure wave.

Chemically pumped laser action is also reported by the Los Angeles Division of North American Aviation. Working under an ONR contract, North American has shown laser output in the 5,000 to 9,000 Å range. Stanford Research Institute last summer triggered lasers with high explosives. Aeronutronics, division of Ford Motor Co., is also carrying out research in this area.

Chemically pumped lasers, which need no bulky electronic power supply and capacitor bank, would have a weight advantage over conven-

tional lasers. North American says one weighing 40 pounds may put out more power than a 1,000-lb conventional device. The capacitor charging interval may also be eliminated. Eventually, says the Army, chemically pumped lasers may be operated at a rate analogous to "machine-gun action."

## Superconducting Device Has High Storage Capacity

SUPERCONDUCTING inductive energy storage system, potentially able to store 100 kilojoules of energy in a 50-liter volume, has been developed by Ion Physics Corp. In its first demonstration last week, a 375-joule prototype fired a laser flash tube, the firm said. The device consists of two joined cylinders immersed in liquid helium—one the inductive energy storage device itself, the other, a high-speed superconducting power switch for stored energy release in high-power millisecond pulses. Besides its compactness, the system can hold energy for



hours with virtually no power loss, the firm says, and requires unusually small low-voltage power sources for charging. Aerospace applications are foreseen.

## Wide-Angle CRT Shrinks Japanese Color-Tv Set

TOKYO—Matsushita has started selling a 16-inch color-tv set with 90-degree picture tube, the first production color-tv set in Japan to have such a wide-deflection angle. Short length of picture tube, 402 mm, enables set depth to be held to only 425 mm. The \$368 set also features a loudspeaker-driving circuit with no output transformer, for improved fidelity. Picture tube has smaller dot spacing than any previous Japanese color picture tubes, for improved resolution.

## Stacked Servo System Studied for Large Radars

LONDON—Royal Radar Establishment, Malvern, is developing a stacked servo system that would al-

low large radar dishes to track and slew more effectively. One system will drive the main dish turntable with the best gear ratio for slewing, while another, a high performance hydraulic servo operating a rotary jack, will actuate the tracker motion. The radar error will drive the antenna servo, and the turntable servo will be driven from a signal proportional to the angular misalignment between the position of the radar beam in space and a datum mark on the turntable.

## Airborne Radio Transmitter Covers the Continent

SYLVANIA has developed a solid-state airborne radio system capable of transmitting to most of North America. The system, which sends out digital waveforms instead of voice, might be used if conventional contact between defense installations fails. Sylvania developed it for Boeing in less than two months, on a quick-reaction basis. Program is part of the Air Force's Project Power Box. System was tested in a KC-135 jet tanker trailing a two-mile wire antenna.

## Reentry Vehicles— How Vulnerable?

WILMINGTON, MASS.—Avco is developing a series of highly instrumented, advance-design vehicles to help determine vulnerability of reentry missiles to nuclear attack. The work is being done under a \$32,635,000 contract from the AF Ballistic Systems Division. The program, designated Sleigh Ride, calls for modifying and reinstrumenting Minuteman-type vehicles. Sleigh Ride, which has gone through several stages, began prior to the nuclear test ban treaty and originally called for flight-testing in a nuclear environment. Presumably, this will now be simulated for the test stages of the program.

### Laser Advance

CONTINUOUS OPERATION of indium-antimonide diode lasers at liquid helium temperatures and high magnetic fields is scheduled to be reported by R. J. Phelan, Jr. and R. H. Rediker, of MIT Lincoln Labs, to the American Physical Society winter meeting in Pasadena Dec. 21. The device uses a higher-purity n-type InSb than the pulsed magneto-optical laser previously reported (p 19, Nov. 1)

## MEETINGS AHEAD

NON-LINEAR PROCESSES IN THE IONOSPHERE MEETING, NBS; Central Radio Propagation Laboratory, Boulder, Colo., Dec. 16-17.

AMERICAN ASSOCIATION FOR THE ADVANCEMENT OF SCIENCE MEETING, AAAS; Cleveland, Ohio, Dec. 26-30.

RELIABILITY-QUALITY CONTROL NATIONAL SYMPOSIUM, IEEE, ASQC, ASME, EIA; Statler Hilton Hotel, Washington, D. C., Jan. 7-9.

INTEGRATED CIRCUITS SEMINAR, IEEE New York Chapter; Stevens Institute of Technology, Hoboken, New Jersey, Jan. 15.

CHARGE TRANSFER COMPLEX SYMPOSIUM, USAF Scientific Research Labs; Denver, Colo., Jan. 19-24.

ANTENNA RESEARCH APPLICATIONS FORUM, Midwest Electronics Research Center; University of Illinois, Urbana, Ill., Jan. 27-30.

INSTRUMENTATION SYMPOSIUM, ISA North Central Area; New Sheraton-Ritz Hotel, Minneapolis, Minn., Jan. 30-31.

MILITARY ELECTRONICS WINTER CONVENTION, IEEE-PTGMIL; Ambassador Hotel, Los Angeles, Calif., Feb. 5-7.

ELECTRONIC COMPONENTS INTERNATIONAL EXHIBITION, FNIE, SDSA; Paris Exhibition Park, Paris, France, Feb. 7-12.

PHYSICAL METALLURGY OF SUPERCONDUCTORS MEETING, AIMMPE Metallurgical Society; Hotel Astor, New York, N. Y., Feb. 18.

INTERNATIONAL SOLID STATE CIRCUITS CONFERENCE, IEEE, University of Pennsylvania; Sheraton Hotel and University of Pennsylvania, Philadelphia, Pa., Feb. 19-21.

### ADVANCE REPORT

ELECTROMAGNETIC COMPATIBILITY NATIONAL SYMPOSIUM, IEEE-PTGEC; Los Angeles, Calif., June 23-25, 1964; Feb. 15 is deadline for submitting completed papers to Mr. John A. Eckert, Technical Program Chairman, Dept. 3441/32, Northrop-Norair, 3901 W. Broadway, Hawthorne, Calif. Some topics include Emc and instrumentation-measurement techniques, microminiaturization, logic technology, program management, space environment, semantic problems, nuclear environment, preventive techniques and design concepts.

## Analog Computer Helps Load Cargo Vessels

LONDON—A built-in analog loading computer to determine trim, shear stress and bending moment of cargo ships has been developed by the Norwegian Industrial and Engineering Research Foundation. Now being manufactured by Sperry Gyroscope of Brentford, the computer consists of an outline plan of the vessel with input knobs to set in the loadings in each fuel or cargo compartment. These are then nulled. The ship's trim and depth can be read off directly from the controls.



## Plant Spending Forecast—Rosy

WASHINGTON—The steady rise in business investment in new plant and equipment will continue at least through mid-1964, says the Commerce Department's Office of Business Economics.

Third-quarter 1963 capital spending hit a record annual rate of \$40 billion, up from \$38.05 billion in the second quarter and \$36.95 billion in the first quarter. The fourth quarter of 1963 and the first quarter of 1964 are expected to level off at \$40.75 billion prior to a rise to \$41.7 billion in second-quarter 1964.

The annual McGraw-Hill survey of capital spending plans (p 19, Nov. 8) found that industry would spend some 4 percent more next year than in 1963. Many economists feel this estimate is conservative, particularly if Congress approves an \$11-billion tax cut.

Capital spending by the communications industry shows an annual rate of \$3.55 billion in the first quarter of this year, \$3.65 billion in the second quarter, and \$3.85 in the third quarter.

### Army to Require Equipment Blueprints

WASHINGTON—Army Electronics Command has revised its procurement regulations to require that complete and accurate drawings be bought from the manufacturer at initial procurement. In subsequent invitations to bid, complete manufacturing data will be made available all prospective bidders. Object is more competitive bidding.

The rules were changed because of complaints by Rep. Earl Wilson, (R-Ind.) about sole-source procurement of pulse transformers and gyrocompass test sets. Army, it was reported, contended it resorted to noncompetitive buying because drawings were not available.

### First Nudets System Rings Washington, D. C.

BOSTON—Air Force Systems Command this week revealed that a prototype of the Nuclear Detonation Detection and Reporting System

(Nudets) has been installed around the Washington, D.C. area. Sensor sites are located in Virginia, West Virginia, Pennsylvania, and Maryland. The computer is at the Pennsylvania site. Sensors are remote from theoretical major target areas to increase survivability. Each site is equipped with optical, seismic and electromagnetic blast-effect sensors. GE is building the prototype system under technical direction from the Mitre Corp. AF Electronic Systems Divisions 477L office manages the program.

### Electron-Beam Welding Outside Vacuum Claimed

AIR FORCE has awarded Hamilton Standard a \$160,000 contract to perfect electron-beam welding outside a vacuum. The firm says it has solved the electron-scatter problem by generating 150 kv or more from a 3-kw electron-beam machine. In so doing, it performed butt welds on a 280-inch stainless steel, with the workpiece placed from  $\frac{1}{4}$  to  $\frac{1}{2}$  inch from the electron orifice, and has achieved a 4:1 depth-width ratio.

### Land-Mobile Study Nears Completion

DALLAS—Results of a comprehensive computer study of land-mobile radio frequency congestion problems will be presented to the FCC about Feb. 1, according to William J. Weisz, of Motorola. He spoke last week at a conference here of the IEEE's Professional Technical Group on Vehicular Communications. [Last year Weisz, as head of EIA's Land Mobile Communications Section, asked the FCC to reevaluate overall spectrum use (p 18, Nov. 30, 1962).]

## IN BRIEF

**RCA and GRUMMAN** have negotiated a \$23.5-million contract under which RCA will supply radar for the Apollo Lunar Excursion Module. This is the first of five contracts expected by RCA.

**DOD** has ordered ten special converters from Westinghouse for the National Emergency Alarm Repeater (NEAR) program. Rated from 5 to 100 kva, the units will transmit a 210 or 270-cycle signal over utility lines, setting off warning devices.

**LITTON** has purchased Clifton Precision. Acquisition had been held up by an IUE strike at Clifton.

**MOTOROLA** president Robert W. Galvin says production of its 90-deg 23-inch color-tv tube—being made by National Video—has been resumed. Yields have been improved, after work on arcing and phosphorous diffusion problems. Motorola hopes to start selling sets early in 1964. Galvin predicted a million-set color-tv market next year, estimated 1963 sales at 600,000.

**AEC SAYS** the nation's second satellite wholly powered by nuclear energy has been successfully launched from Vandenberg AFB, Calif. Transmitter gets its power from a Snap-9A radioisotope generator developed by Martin.

**SEPARATION** of the first and second stages of the Saturn booster scheduled for launch Dec. 18 (p 10, Dec. 6) may be shown live on network tv. On-board camera, operating at 30 frames per second, will televise from before lift-off until impact of the S-1 stage.

**ARGONNE** National Lab's new \$50-million high-intensity proton accelerator, the Zero Gradient Synchrotron (ZGS), could double the world's high-energy physics research capacity, according to an Argonne spokesman.

**HONEYWELL** says it has developed self-healing electronics during a one-year Air Force feasibility study. One approach uses metallic "whiskers" across circuit breaks; another, a remeltable alloy (p 96, Jan. 4).

**MILLETRON** claims success for its subcritical reactivity meter (p 30, Dec. 6), demonstrated last week.

**SHELL** International reports a new linear-programming technique will enable the firm to program the integrated operation of 12 refineries during a five-year period. The system handles problems with 1,500 equations and unlimited numbers of variables.



## **Pentagon Will Put More Into Basic Research**

**Defense spending for basic research** will be increased, according to Deputy Secretary of Defense Roswell L. Gilpatric. Just how much of an increase and in what areas won't be revealed until the new budget is presented to Congress next year. Reason for the increase, Gilpatric said, is the current strength of the U. S. weaponry. This allows more effort to be channeled into pure scientific research, unattached to specific weapon systems. In the current fiscal year, some \$362 million out of a total of \$7.2 billion in military research, development, test and evaluation money goes for basic research.

## **Cost-Cutting Drive Starts Moving Fast**

**Letters that President Johnson** and Defense Secretary McNamara have fired at defense contractors, telling them to cut costs (ELECTRONICS, p 20, Dec. 6), may just be the warning shots. There's indications that contractors who don't cut costs will find it harder and harder to win contracts. Competitive bidding will be emphasized. The swing away from cost-plus to fixed-price and incentive contracts will be accelerated. Cost effectiveness and value engineering—that's the theme in Washington.

The pressure is being placed, too, on the civilian and military personnel who handle contracts. Their attention to cost-cutting will show up on their efficiency ratings.

Net result is certain to be an increasing drive to cut defense costs, with real teeth showing in punitive actions. McNamara claims savings of \$1 billion in fiscal 1963, wants to save another \$1.5 billion in fiscal 1964 and \$4 billion a year by 1967.

## **Nitze's an A-Carrier Man**

**Navy Secretary Paul H. Nitze** will back the admirals in their rift with Secretary of Defense McNamara over a nuclear surface Navy and a force of 15 attack aircraft carriers. McNamara has questioned the value of both. In a Washington press conference, Nitze said "I have discussed my conclusions with Secretary McNamara, and I am very optimistic about the outcome." It will be another year before the issue is tested, however. The forthcoming fiscal 1965 budget carries no request for additional nuclear-powered surface ships.

## **Europeans Seek U.S. Space Aid**

**NASA officials** and representatives of the European Space Research Organization met last week for unofficial discussions. ESRO is a plan for Europeans to pool development of scientific satellites, spending some \$300 million over the next eight years. It was indicated that ESRO wants to launch a satellite in three years with U. S. cooperation, and have at least 10 projects going within 5 years. Besides scientific goals, the organization is to provide European industry with space-age technology. Countries will share technology. ESRO headquarters are in Paris, a technical center will be in Holland, data-processing in Germany, a rocket range in Sweden and a technical institute in Italy.

## **NASA Budget To Rise Again?**

**White House sources indicate** that President Johnson may request a supplemental budget for space next spring. It would, they say, establish the importance he places on the space program and recapture some of its lost urgency. NASA officials say they need to get back most of the \$600 million that Congress trimmed from this year's \$5.7-billion budget to get a team of astronauts on the moon this decade. It would mean a total budget of about \$6 billion in fiscal 1965. The budget, already largely prepared, falls short of that.





A "slightly exaggerated" portrayal of Technical Director Robert V. Higdon on his way to customer counseling in the Electronics Industry

## Nothing stops Chase Manhattan men from reaching you with the key to your financial planning



Any conveyance will do.

Resourceful and imaginative specialists of The Chase Manhattan Bank's United States Department will any day travel anywhere to counsel with good customers. And, wherever they go, they have a hard-headed slogan:

*"We try not to tell good customers why it can't be done. We do our level best to tell them how they can do it."*

This adds considerably to the versatility of the big key the Chase men carry.

Backing each officer of the Bank is a line and staff organization of 16,000 skilled and experienced people. At a word from a customer, they go into action. Then into the field goes every resource, every ounce of lore and knowledge stored up in the nation's number-one bank lender to business and industry.

In brief, if you become a customer of The Chase Manhattan Bank, you'll get continuous, cooperative counseling—the true key to your financial planning.

**THE CHASE MANHATTAN BANK**

1 Chase Manhattan Plaza, New York, N. Y. 10015

Member Federal Deposit Insurance Corporation





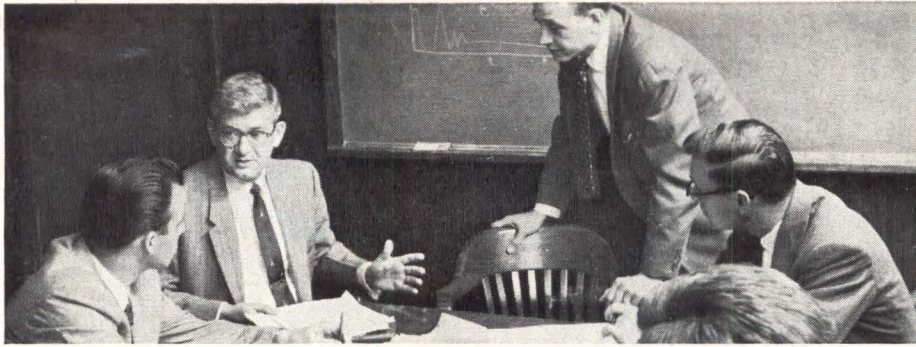

In January, 1963 a dynamic new dimension was added to Lockheed Missiles & Space Company in Huntsville, Alabama.

LMSC's now well-established Research & Engineering Center was created to lend close support to the George C. Marshall Space Flight Center, founded by NASA to furnish vehicles for space programs; and the Army Missile Command, home of the Army's missile programs.

The Huntsville Research & Engineering Center, adjacent to the University of Alabama's new Research Center, is largely self-sufficient, capable of carrying out a wide variety of programs. Its capabilities include: Advanced engineering; analytical studies; hardware design, development, manufacturing, testing and evaluation. Specific studies, such as analyzing

guidance systems, trajectory computation, optimization of payload and accuracy, post-flight analysis, and thrust vector control through secondary injection, are already being accomplished.

Living in the Huntsville area is delightful. The city, a metropolis of 120,000, is modern and bustling—the fastest growing city in the Southeast. Nearby lakes and rivers provide excellent fishing and water sports. Its scenic countryside offers a wide variety of game to the hunter. New housing is plentiful. Schools have kept pace with the rapid population growth, as have the churches and civic organizations.

In all, you will enjoy living in Huntsville. And you'll appreciate the rare challenge of growing with a new, ambitious organization.

**LOOK AT LOCKHEED...AS A CAREER**

Consider Lockheed's leadership in space technology. Evaluate its accomplishments—such as the Polaris missile and the Agena vehicle's superb performance records. Examine its outstanding advantages—location, advancement policies, creative climate, and opportunity.

Then write for a brochure that gives you a more complete Look at Lockheed in Huntsville. Address: Lockheed Missiles & Space Company, Huntsville Research & Engineering Center, P.O. Box 1103, West Station, Huntsville, Alabama.

**SCIENTISTS & ENGINEERS:** Current positions available in Huntsville include work in the following areas: Guidance analysis • Electronics • Stability & control • Astrodynamics • Dynamics performance evaluation • Aerodynamics • Gas dynamics • Control systems analysis • Thermodynamics • Structural dynamics • Computer programming • Propulsion • Flight Mechanics • Optimization techniques in mathematics.

**LOCKHEED**  
**MISSILES & SPACE COMPANY**  
A GROUP DIVISION OF LOCKHEED AIRCRAFT CORPORATION  
AN EQUAL OPPORTUNITY EMPLOYER

**LOOK AT LOCKHEED...IN HUNTSVILLE**

*Introducing Lockheed's new Research & Engineering Center*

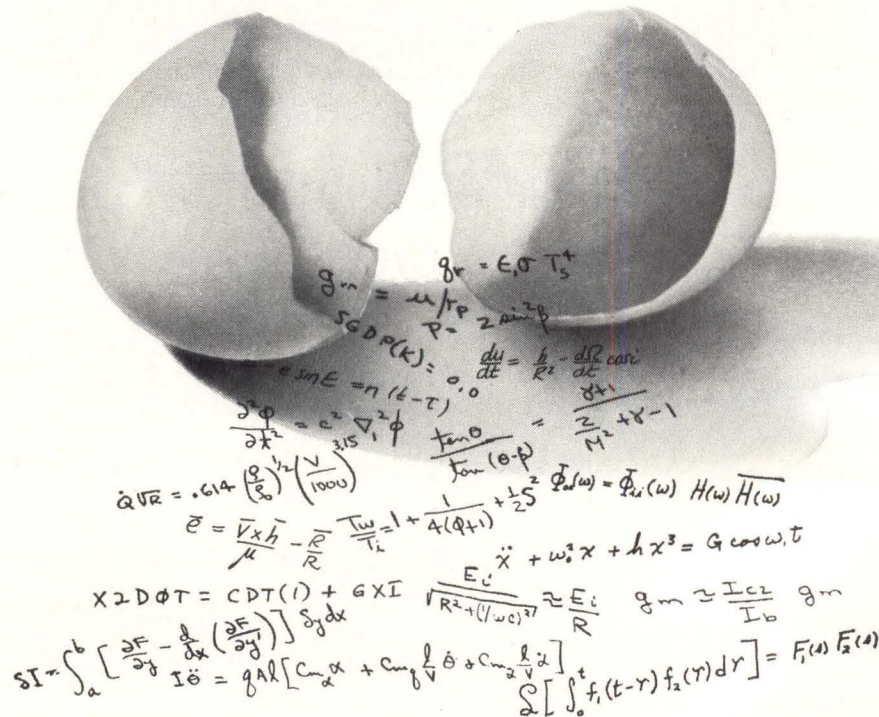





## RUB A DUB DUB ONE IN THREE SCRUB

When we make a relay, every third production step is a cleaning operation. But cleaning in Filtors' Total Contamination Control Program involves more than just soap and water; it's a carefully researched effort to extract what may be harmful and to prevent the introduction of other contamination. The last, and most vital, step in the TCC Program is sealing the relay. We use an electron-beam process. The relay is sealed in a near-perfect vacuum without flux and with a minimum of thermal distortion. There are more details in our facilities brochure. May we send you a copy?

Write Dept. D.

# FILTORS, INC./RELAYS

EAST NORTHPORT, L.I., NEW YORK. 516-AN 6-1600

A Division of General Battery & Ceramic Corp.



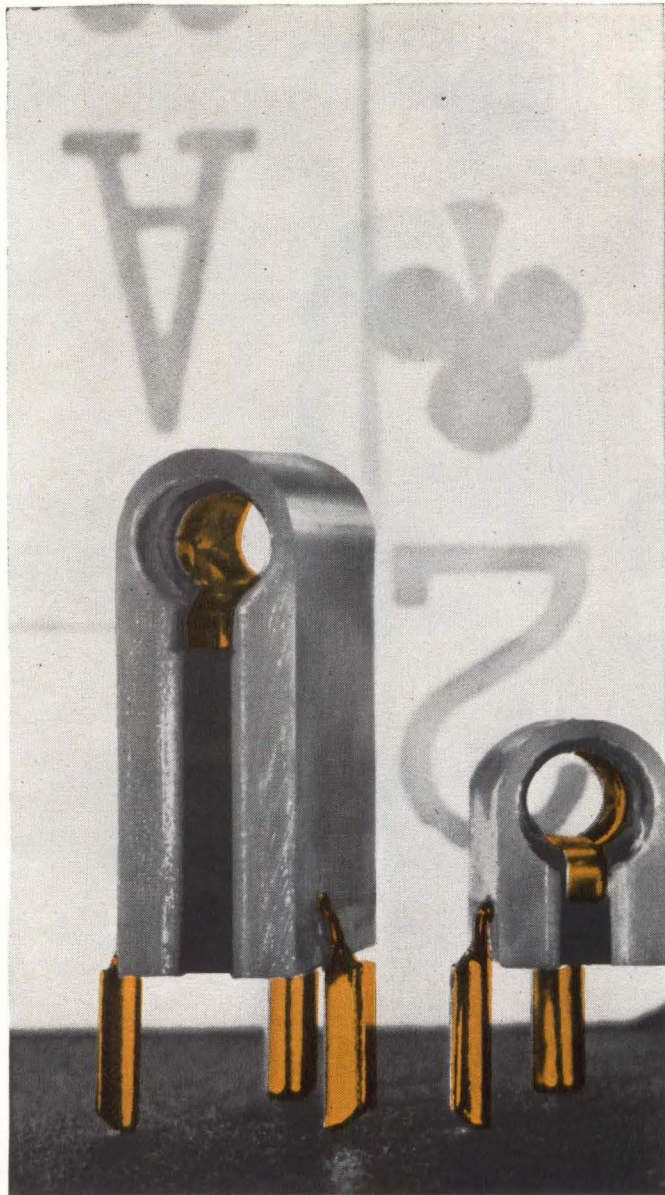

## High . . . low . . . and jack!

Now, you've got pat-hand testing of printed circuitry that's hard to beat! Two and three-legged probe receptacles, high and low types, for testing circuit continuity. A reusable Matrix Jack for "burn-in" testing of components. Both very uncomplicated and both very good.

For instance, our reusable Matrix Jack is a natural for saving potfuls of money. It lets you test components without soldering with repeated use of the same board and . . . it can be used over and over again. No more burned components. No more wasted boards. Ever! It's so simple a solution to the problem, we're glad we thought of it first. Just a drawn brass cup with a built-in spring receptacle that accepts component leads of varying diameter and holds them steady and snug for maximum conductivity and true readings. Components can be hand inserted and removed.

The test probe receptacles can be mounted on board edge or in the middle of the board and their "V" shaped legs promote controlled solder wicking to hold them steady and straight and give you sure contact for reliable testing. Take just a few seconds now to get the run down of AMP features that take the element of chance out of printed circuit testing:

### TEST PROBE RECEPTACLES

- 10 nylon housing colors for easy identification and location
- Recessed inserts—gold or silver plate
- Either end entry for probe
- Accepts standard .080 probe

### REUSABLE MATRIX JACK

- Fits one hole size—.089
- Accepts wire leads—.018—.040
- Two ounce extraction force
- Eliminates solder and heat damage to boards and components

Want to see a sample or two? We'll send it along with detailed information immediately upon your request.



AMP products and engineering assistance are available through subsidiary companies in: Australia • Canada • England • France • Holland • Italy • Japan • Mexico • West Germany



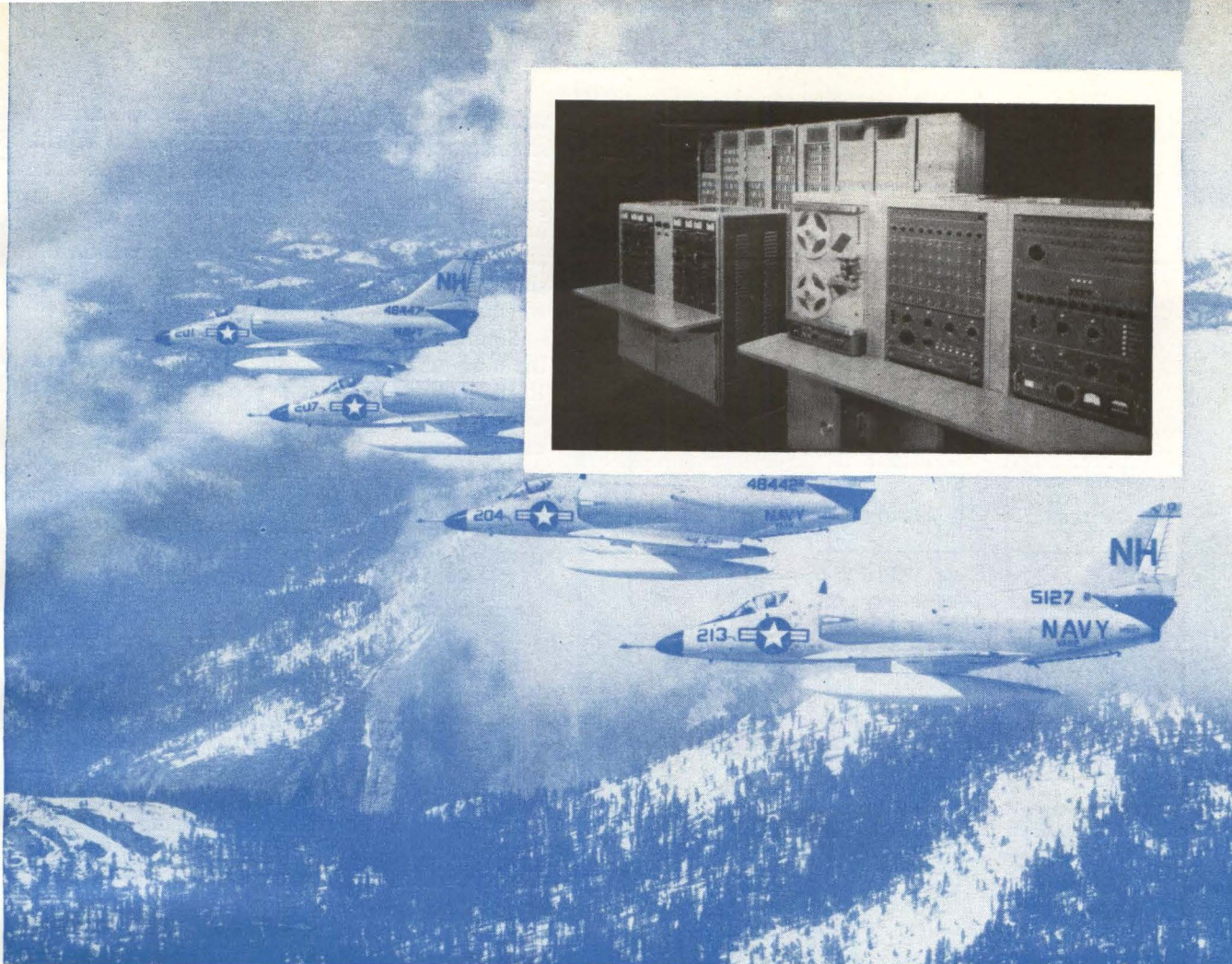

HYBRID RADAR SIMULATOR includes analog target control unit (left foreground of inset) where instructor "flies" target plane. Tape handler plays prerecorded tapes carrying additional target planes. Computing equipment in rear racks generates aircraft tracks and coincidences between radar beams and aircraft. Teaches by proceeding from simple to complex problems

## SIMULATING TACTICAL RADAR AND SONAR

Time compression, beam forming, and analog and digital computing techniques are but some of the areas involved in realistically simulating conditions to fully test machines and train men

By **R. G. HUNDLEY**, Supervisor,  
General Applied Science Laboratories, Inc.,  
Westbury, N. Y.

**TRAINING AND TESTING** modern day weapons systems, where system consists of man and machine, can be done by electronically generating realistic inputs to stimulate the system and also to measure the system's response. Traditionally weapons systems were tested by staging actual war games. Electronics has been, and is, taking over. Such a simulated war game, with a remarkable degree of realism, is usually controlled by an independent observer, who can manipulate the targets in order to test and evaluate the system's strong and/or weak points. Besides giving a big picture, the simulator teaches by proceeding from the simple, one loud target in a noiseless ocean, for example, to the complex, many loud and quiet targets in a noisy ocean.

Until recently, if the attitude of expense be damned



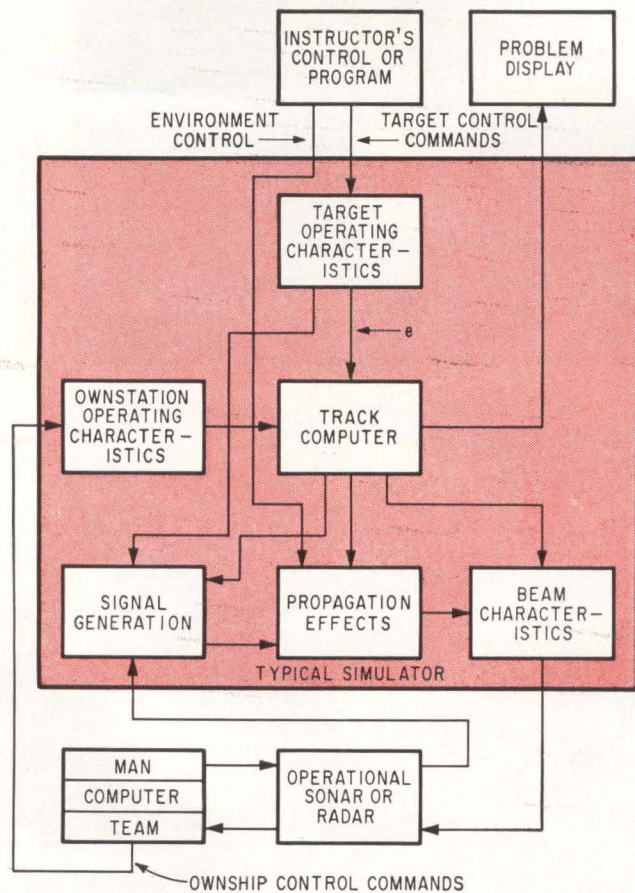

TYPICAL SIMULATOR tied into a complete trainer system shows the underlying unity of radar and sonar simulation problems and parallel-paths to their solutions—Fig. 1

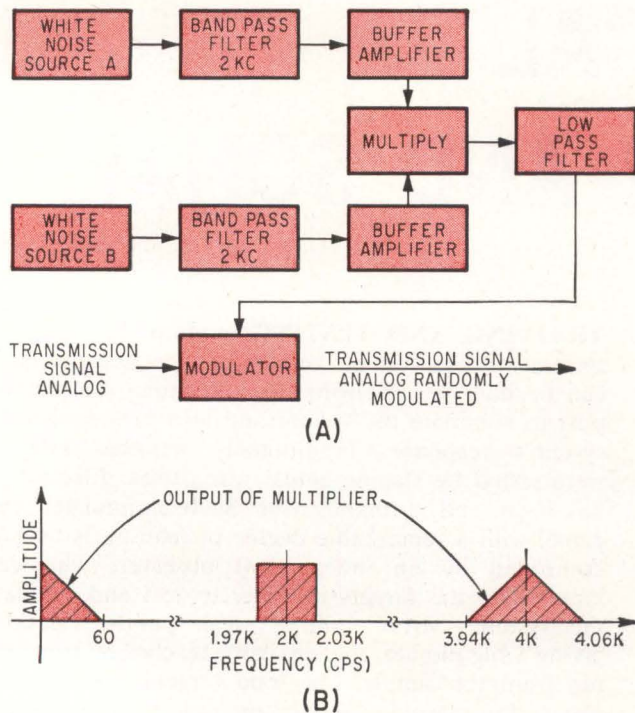

RANDOM NOISE generation system (A) is a requirement of realism; idealized spectrum (B) of system—Fig. 2

were taken, any realistic war game problem that was simulated could also be staged in the real world. For example, it is possible to have maneuvers at sea by placing a number of friendly ships, to serve as targets, in the ocean relative to ownship, have them maneuver according to plan and observe the reaction of ownship's equipment and crew. But this is no longer true when Apollo mission simulation is considered.

Simulation can provide realistic inputs to exercise the man-machine organism known as Sonar or Radar. If the emphasis is on the machine, exercise in the sense of test is implied; if emphasis is on the man, exercise in the sense of training is implied. The word tactical describes the fact that the simulator represents a controlled, dynamic, tactical situation of ownstation (submarine, surface ship, aircraft, missile or fixed site) targets, and environment.

Since the propagation of sound energy and of electromagnetic energy are governed by an analogous set of physical laws, the simulation requirements for sonar and radar are quite similar in principle and may be discussed in a parallel manner. Indeed, the actual implementation of the simulation has been similar and in some cases nearly identical.

**Typical Simulator**—Figure 1 shows a block diagram of a typical simulator and how it ties-in with a complete trainer system. This general diagram describes either a sonar or a radar trainer and illustrates the underlying unity of sonar and radar simulation. The instructor's control or program, in effect, gives the commands that sail the ships or fly the planes. But independent of the program commands, ownstation and the targets are constrained to obey these commands realistically.

**Track Computer**—Based on the actual three dimensional velocity of a target,  $e$ , the track computer integrates in real time and yields the present position,  $e$ , of target relative to the problem frame of reference. In some cases, past stored tracks are required where ship's wakes, ionized missile trails, or sub-snorkel smoke trails are being simulated.

Ownship is typically controlled either singularly or in combination by man, computer, or a team block. The word team is best explained by an example. In a modern sub, the sonar operator provides one of many possible inputs for the decision making process. Aided by a complex network of data processing, the captain ultimately decides on the ship's course of action. Once his decision is made, another man-machine organism must implement his decision, such as the crew and diving apparatus.

Based on the relative position and velocity of ownship and target inputs from the track computer, the propagation effects block modifies the electrical analog of the sound (or electromagnetic radar echo) signal for amplitude and frequency content. The originating signal, in general, is generated on the basis of target type, target dynamic condition, and target orientation; and for active systems, the timing of the echo return is based on ping or main bang time established at the operational sonar or radar, relative position, and propagation parameters.

The output from the propagation effects block, rep-



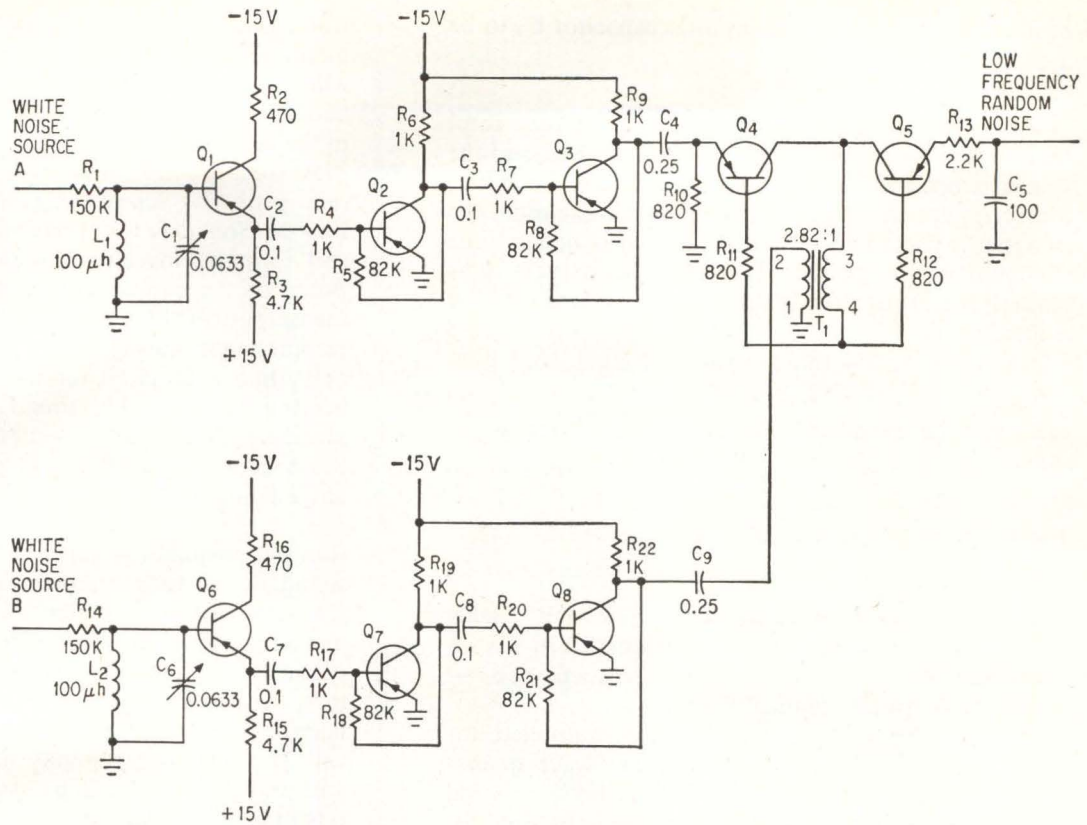

LOW FREQUENCY noise generator—Fig. 3

resents the signal as it would be presented to the antenna or transducer array. These arrays generally have directional characteristics in azimuth and elevation. Based on the present time geometry of the problem, the track computer feeds the relative azimuth and elevation angle to the beam characteristics block. This block feeds the properly phased signals to the front of the operational sonar or radar.

The track computer controls the problem display block by which the instructor evaluates the overall tactical situation and the response to the situation made by the man-machine organism being exercised.

**Engineering Disciplines**—Successful simulation draws on a broad spectrum of engineering discipline. A narrow approach, such as electronic analog, applied to every problem may yield some sort of a workable solution but never consistently the best (best being defined as the optimum combination of realism, reliability, maintainability and economy). Some specific problems and their solutions follow.

**Random Fading**—Random fading of received signal is experienced for electromagnetic transmission through space as well as for sound transmission through the sea. A cause in both cases is the instability of the transmitting medium which may specifically be described as a non-stationary complex interaction of direct path, reflected path, refracted path, and scattered transmission.

Realism requires the generation of a random low frequency signal. A random noise generation system is shown in Fig. 2A. White noise from source A is narrow-band filtered at center frequency 2-kc, and applied through a buffer to the multiplier. The multiplier output is routed to the low-pass filter. The out-

put of the multiplier has a frequency spectrum content as indicated by Fig. 2B, which is an idealized picture of the spectrum of significant signals. The 3 parts of the spectrum are the sum frequency component extending from 3.94 to 4.06-kc, the input frequency component extending from 1.97 to 2.03-kc, and the low frequency component extending from zero to 60-cps.

Figure 3 shows the 1-f random noise generator circuit used in Fig. 2A. All transistors are type 2N1377. The output (Fig. 2A) of white noise source A is filtered by a parallel resonant circuit at the input of the emitter follower formed by  $Q_1$ . The signal is amplified through two grounded emitter stages formed by  $Q_2$  and  $Q_3$  and applied through capacitor  $C_4$  to a symmetrical switching circuit consisting of  $Q_4$ ,  $Q_5$  and  $T_1$ . The white noise from source B is filtered and amplified in the exact same manner through  $Q_6$ ,  $Q_7$  and  $Q_8$ . The amplified output is applied through capacitor  $C_9$  and transformer  $T_1$ .

When the instantaneous polarity of the secondary of transformer  $T_1$  is such that terminal 3 is negative with respect to terminal 4, the collector-to-base diodes of both  $Q_4$  and  $Q_5$  are back-biased, and the filtered and amplified white noise (source A), coupled through  $C_4$  and  $R_{10}$  to  $Q_4$ , is not passed. When the instantaneous polarity of the secondary of transformer  $T_1$  has terminal 3 positive to terminal 4, both collector-to-base diodes of  $Q_4$  and  $Q_5$  are forward-biased and the signal applied through  $C_4$  is passed. The secondary of  $T_1$  is not referenced to ground to prevent the switching voltage from appearing as part of the output, which is referenced to ground. The low pass filter, composed of  $R_{13}$  and  $C_5$ , filters out unwanted high-frequency components. Multiplication is by the on-off switching of  $Q_4$  and  $Q_5$ . For purposes



of illustration, consider the input at capacitor  $C_4$  to be a sinusoid

$$A = V \sin \omega_1 t \quad (1)$$

Consider the switching voltage to be of such form that the switch is closed for  $t = 0$  to  $t = T/2$  and the switch is open for  $t = T/2$  to  $t = T$  and thereafter, the cycle repeats itself. When the switch is closed, the  $A$  signal is passed and when the switch is opened, the  $A$  signal is not passed. This may be expressed as multiplying  $A$  by the function  $\mu(t)$ , where  $\mu(t)$  is defined as

$$\mu(t) = 1 \text{ for } t = 0 \text{ to } t = T/2 \quad (2)$$

$$\mu(t) = 0 \text{ for } t = T/2 \text{ to } t = T \quad (3)$$

$\mu(t)$  may be expanded into an infinite series as

$$\mu(t) = 1/2 + 2/\pi (\sin \omega_2 t + 1/3 \sin 3 \omega_2 t + 1/5 \sin 5 \omega_2 t) \quad (4)$$

where,  $\omega_2 = 2\pi/T$

The product  $A \times \mu(t)$  may be expressed as

$$V \sin \omega_1 t [1/2 + 2/\pi (\sin \omega_2 t + 1/3 \sin 3 \omega_2 t + 1/5 \sin 5 \omega_2 t)] \quad (5)$$

Performing the indicated multiplication yields cosinusoidal terms involving the argument  $\omega_1 t$ ,  $(\omega_1 + \omega_2)t$  and  $(\omega_1 - \omega_2)t$ . The difference frequency  $(\omega_1 - \omega_2)$  can be 0-cps for identical  $\omega_1$  and  $\omega_2$ .

Actually, the two signals that are multiplied together are not a sinusoid and a square wave of discrete frequencies, but two noise bands both centered about the same frequency. But as indicated by Fig. 2B, a band of different frequencies and a band of similar frequencies are generated as well as the original input band. The difference frequency band peaks at 0-cps because each band is centered at 2-kc and any frequency in one band can be matched against an identical frequency in the other band for the entire bandwidth. But for 60-cps difference, only the top of one band, say at 2,030-cps, and the bottom of the other band at 1,970-cps, can yield 60-cps difference.

**Beam Forming**—Many modern day sonars have multielement hydrophone arrays which yield highly directional beam characteristics. The same statement holds for radars. In a 10-hydrophone array the ray path line of an impinging wave front divides the array symmetrically and travels down the array at the speed of sound in water. The wave front meets hydrophone 1 Left and 1 Right at time  $t_1$ , at some time later,  $t_2$ , the wave front passes 2L and 2R and so on through 5L and 5R. If these hydrophones are connected to delay lines, where the electrical delay is equal to the acoustic delays in the water, two reinforced signals, labeled left signal and right signal, of equal amplitude are obtained. Symmetry can be precisely tested for by measuring the difference between left signal and right signal. Within system noise and inaccuracies, this difference approaches 0 for the symmetrical case.

To make the array steerable, that is, obtain reinforcement along any angle of impinging ray path, a switching system, (compensating switch) shown by Fig. 4A, is interposed between the hydrophones and the delay lines. The brush switching system forms a model of the array in the water (where the brush position is scaled to the hydrophone locations in the water) and the delay along the bars is equivalent to the acoustic delay through the water. The brushes are

trained along the brush locus for maximum reinforcement. Each brush touches the static switch plate which consists of alternating parallel conducting bars and insulation. The bars are connected through taps to the delay line.

A sophisticated simulation technique, used to obtain properly delayed signals for front end entry into the Sonar, is to reverse the signal flow (Fig. 4A) and form an inverse compensating switch, Fig. 4B. Based on the explanation of the compensating switch, the outputs of the inverse switch will have delays corresponding to the signal in the water. Only one tapped delay line is required for the inverse switch. Relative bearing of the target sound source, which is computed by the central computer, is required to turn the brush array on the brush locus, simulating the target at the computed bearing.

**Range Attenuator**—Range attenuation of underwater sound is due to a number of effects. In all cases, a spreading loss is experienced. In an ideal boundless medium, spherical spreading is the rule. Since the ocean is roughly bound at the surface and at the bottom, which for certain conditions act as good reflectors, the spreading for long range can be cylindrical. This loss is essentially non-frequency dependent and may be simulated by positioning a transmission potentiometer slider arm as a function of range.

In a similar manner, refractive effects through the water can cause either a divergence yielding an additional loss (shadow zone effect) on top of the spreading loss; or conversely, a convergence yielding a gain (convergence zone) off-setting to some degree, the spreading loss. This loss, essentially non-frequency dependent, is a function of depth, sound velocity versus depth profile, and range. It is simulated in the same manner as spreading loss.

Absorption loss, due to non-ideal dissipative effects of friction of the ocean transmitting medium, is both range and frequency dependent. This behavior is shown in Fig. 5A. The electrical analog of the ocean can be built up by a group of cascaded low pass filters. As the frequency is increased for a fixed range, the response drops off. Figure 5B is a range attenuation potentiometer which combines both spreading and absorption loss simulation. A linear potentiometer of resistance  $R$ , is tapped at 5 points to form resistive sections of resistance,  $R_1, R_2, R_3, R_4, R_5$ . At very low frequencies, the shunting effect of  $C_1, C_2, C_3$ , etc., is negligible and the target sound, voltage analog, divides resistively across the precision potentiometer. For spherical spreading

$$\frac{I_1}{I_2} = \frac{V_1^2}{V_2^2} = \frac{R_1^2}{R_2^2}$$

where:  $I_1$  = intensity of sound at transmitter;  $I_2$  = intensity of sound at receiver;  $V_1$  = voltage analog of sound pressure at transmitter;  $V_2$  = voltage analog of sound pressure at receiver;  $R_1$  = reference range of transmitter =  $K$ ; and  $R_2$  = range receiver. The slider arm of the pot is positioned to an angle proportional to  $K/R_2$  to simulate spreading loss.

As the frequency is increased the attenuation increases more and more above the spreading loss. Consider the 10,000 yards range curve (Fig. 5A) where the response at 5-kc is down 3-db from the



response at 0.1-kc. The tap point for  $C_1$  is chosen at that position which the pick-off rests for range equal to 10-kyds.

As a first approximation, capacitor  $C_1$  is chosen in conjunction with  $R_1 - R_6$  to yield a low frequency break at 5-kc (break frequency is that point at which amplitude versus frequency response of a low pass filter is down by 3-db). If the shunting effect of  $C_2 - C_6$  is neglected, the equation

$$T = R' C = 1/2 \pi 5 \times 10^3$$

determines  $C$ , where

$$R' = \frac{R_1 (R_2 + R_3 + R_4 + R_5)}{R_1 + R_2 + R_3 + R_4 + R_5}$$

**Plasma Wakes**—Missiles entering the atmosphere at hypersonic speeds ionize the air about their bodies, leaving an ionized wake or trail in their track path. The plasma, characterized by a density of free electrons, has reflective characteristics for radar signals. In so far as simulation is required, two significant phenomena are that the radar cross section increases around the body of the missile; and that the reflective trail stretches behind the body many thousands of feet.

Essentially, the simulation of a wake requires the

storing of the missile tracking information. Simulation design must be based on estimated maximum length of missile wake decay time. As an example, take a decay time of 2 seconds, with the least significant bit in the track computer specified as 60 feet. With 20 bits the largest positional parameter required and using a 5-Mc clock rate in serial form, 4  $\mu$ sec. of time are needed to describe the largest positional parameter.

Maximum speed of an impinging missile is set at 20,000 feet per second. In 2 seconds, a maximum translation of 40,000 feet is possible. The track information is stored in a circulating delay line with an access time of 1 millisecond, the circulate time of the delay line shown in Fig. 6. This permits 250 words of 20 bits each to be stored in the circulating delay line in serial form. For a maximum translation of 40,000 feet, this yields a maximum granularity in the stored track of 40,000 divided by 250 equal to 160 feet. To delineate 160 feet at a maximum speed of 20,000 fps, it is necessary to sample the track at a rate of at least once every 160 feet divided by 20,000 fps, which equals 8 milliseconds.

In Fig. 6, the entry gate,  $EG$ , is generated once every 8 milliseconds less 20 bits or 4  $\mu$ sec.  $EG$  gates the  $X$  coordinate of the generated track into the delay

STEERABLE sonar array switching system (A) can be sophisticated by use of inverse compensating switch (B) for properly simulated signal delays in water—Fig. 4

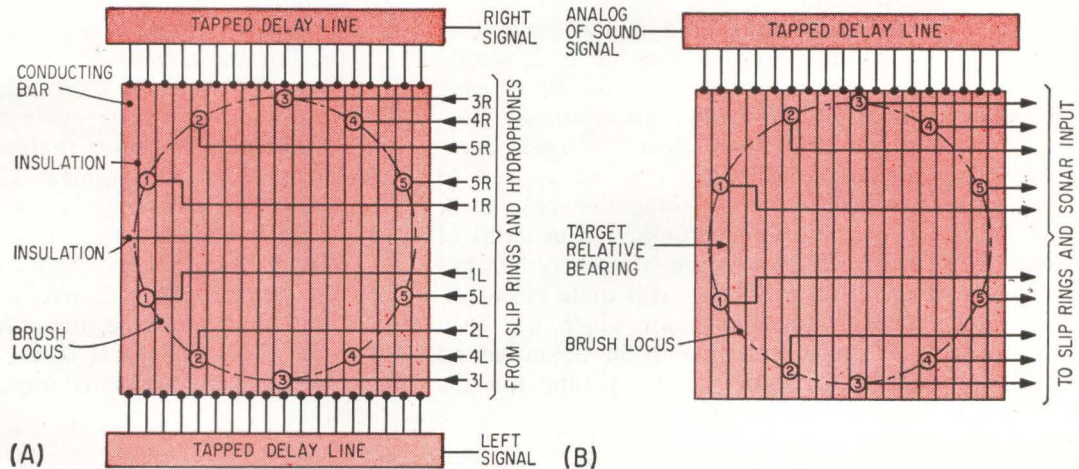

UNDERWATER SOUND in a nominal direct path propagation loss as a function of frequency (A). Range attenuation potentiometer (B) combines both spreading and absorption loss in a single unit—Fig. 5

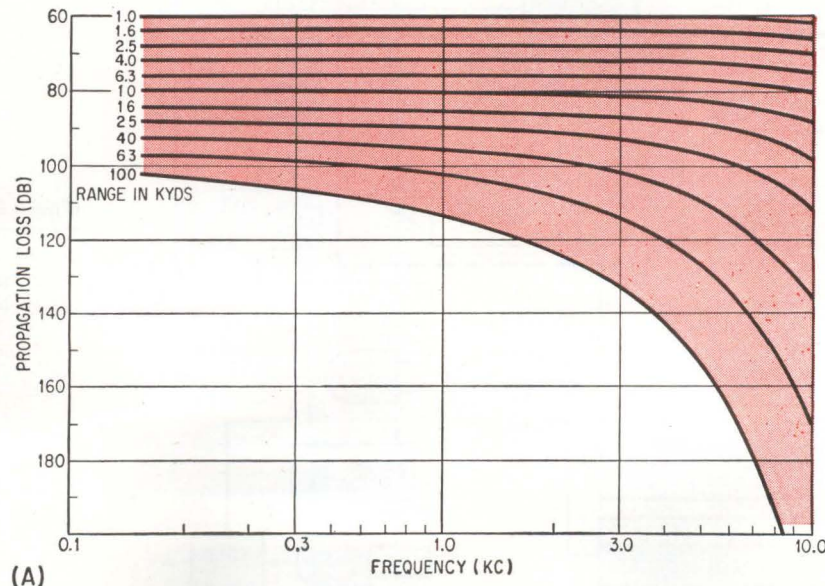



line. The timing of *EG* places the words in adjacent slots in the circulating delay line. The erase-gate, *ERG*, generated in synchronism with *EG*, clears the delay line of old track information, which for this storage scheme is 2 seconds old. The 5-Mc clock pulse maintains line synchronism. The comparator gate compares the *X* coordinate of the search radar in serial form with the latest 2 seconds (real time) of the stored track of the missile. The same process is carried on simultaneously for the *Y* coordinate and the height parameter (*H*).

Simultaneous coincidence of *X*, *Y* and *H* during any part of the review of the stored coordinate information indicates a radar coincidence with the latest 2 seconds of the missile track and a possible radar reflection. The hold circuit maintains a coincidence until the next review of the delay lines indicates whether or not a coincidence occurred for the new condition. The weighting of the return based on decay time and radar type is implemented by a synchronized sawtooth generator and shaping network. The weighting AND gate transmits the shaped sawtooth level to the hold circuit corresponding to the reflected echo strength. Different radars operating at different r-f frequencies will have a characteristic shaping network to modify the strength of the echo return from the wake.

Wake simulation consists of a digital method of storing the past track information for a 2 second period. This is a dynamic storage and stores only the most recent track information, automatically erasing track information of more than 2 seconds duration. This simulation technique may be applied to any problem which requires storage of past track information. For the example considered in terms of time, the stored track information is not very old, but of course, in terms of translation, it is quite extensive.

Another type of wake simulator which has been constructed is for turbulent wake in the ocean behind a moving vessel. The order of decay time for this

wake is minutes but, since the motion of the ship is a couple of orders of magnitude slower than an entering missile, the total length of the ocean wake is comparable to the plasma wake. The storage of the wake in both cases is really a time compression technique, enabling a review in present time to be made of past track information.

**Target Control Simulation**—Figure 7 is a representation of part of a target control system used in a radar simulator. This target control section is essentially analog in principle. The *X* velocity and *Y* velocity components of the aircraft, (the output of this analog portion) are realistically generated based on pilot control of the aircraft. The track in this particular machine is maintained by a very accurate digital computer. The analog system, of course, is not nearly as accurate as the digital track part, but is realistic since the manner in which a pilot actually controls his aircraft is analog proportional in principle. The way in which a pilot flies a precise course is by means of periodic navigational fixes at which point the pilot corrects for any accumulated error. In a very similar manner the digital track computer keeps track of the plane's exact position, the instructor playing the part of the pilot and looking to the digital computer to give him a navigational fix.

Figure 7 shows some of the methods used for controlling the target. The percent-power-desired, which is a pilot control in most aircraft, is cranked in by the instructor.

The percent-power shaft turns the split stator segment. When this segment is turned from the position shown, the pointer (which is geared to percent-power-actual) touches the stator segment and completes the circuit from the servo amp to the servo motor. Where the percent-power-desired is increased, the acceleration crank would be turned to some positive acceleration. This voltage is servoed by the velocity servo. The velocity servo is implemented by a feedback

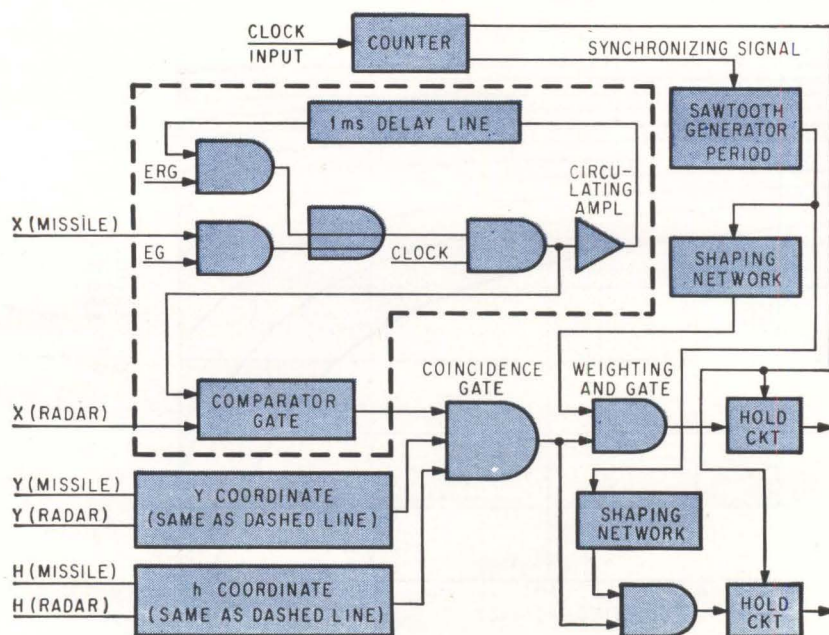

MISSILE WAKE radar return simulator is based on the estimated maximum length of the wake decay time—Fig. 6







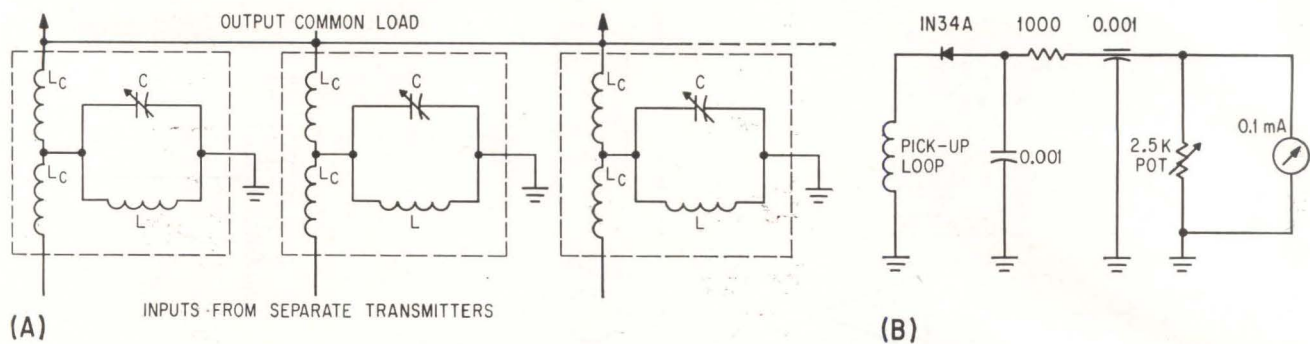

SYMMETRICAL circuit maintains unity impedance transformation independent of frequency (A). Tuning indicator (B)—Fig. 1

# Multicoupler Puts Five Transmitters

Placing a separate and independent network—a symmetrical, tuned L-C circuit—between each transmitter and the common load results in only one additional tuning adjustment for each transmitter

**ATTRACTIVE** and straightforward approach to transmitting-multicoupler design is to interpose a separate and independent network between each transmitter and the common load. The technique was suggested by Robert Tanner of TRG West.

Each network acts as a direct connection at transmitter frequency, but presents, at other frequencies, a high impedance to the common load. A series-resonant L-C combination between each transmitter and the load illustrates the principle. Considerations of convenience and realizability make a simple series-resonant connection impractical; the necessary degree of circuit complexity is a sensitive function of the minimum frequency spacing between transmissions and degree of isolation required.

As the starting point, in a Radio-

science Laboratory research project, it was arbitrarily decided that the transmitting-station operator could tolerate no more than a single additional tuning adjustment per transmitter, and that adjustment of any one of the networks must not affect operation of the remainder of the multicoupler or of the other transmitters sharing the antenna.<sup>1</sup>

A single tuned-circuit is thus specified, with the additional requirement of single-ended, 50-ohm input and output. The filter-circuit presents a high, off-frequency impedance to the common load and, on-frequency, connects a resistive common load directly to the transmitter.

**Symmetrical Circuits**—The symmetrical circuits of the multicoupler (Fig. 1A) also have the desirable property of maintaining a unity im-

pedance transformation independent of frequency, plus capacitor tuning for mechanical simplicity. The circuit results in loaded  $Q$  linearly proportional to frequency  $f$ , and with inductive coupling has an octave frequency range.

Component values of multicoupler circuit Fig. 1A are determined by the desired frequency range, load impedance, and tradeoffs between isolation, load reactance, number of transmitters, freedom from interaction, and insertion loss.

**Five Transmitters**—For this application, it was desired to couple as many as five transmitters into a common h-f antenna useful over an octave frequency range. The transmitters (600-w, c-w) were to operate as close as 1-Mc in the 1 to 16-Mc band without generating cross-products stronger than 40-db below the carriers. For simplicity, all multicoupler sections were made identical and capable of covering the full octave.

The insertion loss was specified to be less than 1-db to minimize cooling problems. If some value for unloaded tuned-circuit  $Q$  is assumed (500, based on a preliminary experiment to determine a value easily obtainable without unusual care in

Typical Values for 50-Ohm Load Impedance

Frequency (Mc)	C (pf)	L ( $\mu$ h)	L <sub>c</sub> ( $\mu$ h)
5.5-11	25-500	2	14
8-16	25-500	0.8	6.8
13-26	25-500	0.3	3.3



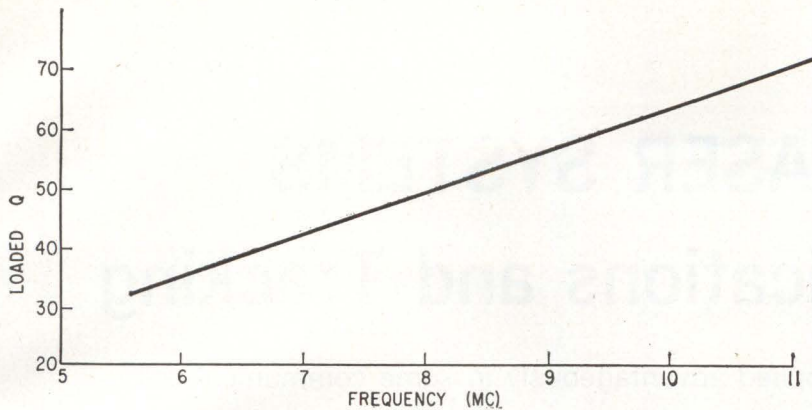

TYPICAL filter Q increases linearly with frequency—Fig. 2

## H-F JUXTAPOSITION

Point-to-point and broadcast stations do not usually transmit several h-f frequencies simultaneously over one antenna, as is done at receiving stations. Operators often lack the time, equipment, or ability to readjust a complicated multicoupling network for each frequency change or added transmission. The unit described below simplifies these operations

# on One Antenna

By G. H. BARRY and J. D. HAWKINS  
Radioscience Lab., Stanford Univ., Stanford, Calif.

design or construction) the loaded-filter Q is defined by

$$\text{Loss (db)} = 20 \log_{10} \frac{1}{1 - (Q_l/Q_u)}$$

where  $Q_l$  and  $Q_u$  are the loaded and unloaded Q's respectively. Loaded Q was designed to vary from 30 to 60 over each octave band, satisfying the loss requirement as well as providing adequate isolation between adjacent transmitters.

The off-frequency filter networks represent essentially shunt inductances in parallel with the common load and the value of coupling inductance  $L_c$  must be high enough so that these shunting reactances do not make the load unacceptable to the transmitter. Our transmitters (Collins 30S-1 linear amplifiers) have a 50-ohm output impedance and require a vswr of less than 2:1.

**Construction** — Three five-channel multicouplers were constructed and have been in daily use for nearly a year. The table gives the frequency ranges of the three, together with the component values.

The filters were constructed within separate sheetmetal boxes, each mounted on a 10½-in. rack-mounting panel and installed in enclosed racks. The interior of one of the filters is shown in the photograph. Cooling is provided by small fans attached to the side of each box.

As an aid in tuning the multicoupler, a pickup loop is installed near the ground connection of each

resonant coil. Energy from this loop is detected by a simple diode circuit. (Fig. 1B) whose output operates a 0 to 1-ma meter on the front panel. The operator may tune either for maximum meter reading or, if transmitter is provided with output power metering, for maximum, net, forward power.

**Operation**—The multicouplers operate very much as expected. The filter Q increases linearly with the frequency (Fig. 2). The measured insertion loss implies an unloaded Q of approximately 700 at 8-Mc.

An appreciable improvement (a factor of 2) on this value could be made within overall package size by more careful mechanical design. The advantage of higher Q could be taken in the form of lower insertion loss, greater isolation, or closer frequency spacing, depending on choice of circuit-element values.

Impedance seen by a transmitter is plotted as a function of operating frequency (returning filter at each frequency and keeping other filters at least 0.7-Mc away) on the Smith chart, Fig. 3. Interior of the heavy circle (vswr = 2) is the region acceptable to the transmitter.

The units described were designed for approximately 600-w per transmitter and would operate conservatively up to perhaps 1,500-w.

## REFERENCE

(1) Multicouplers developed at the Stanford Radioscience Laboratory for use on an ionospheric research project sponsored by ARPA through the Office of Naval Research, Contract Nonr 225(64).

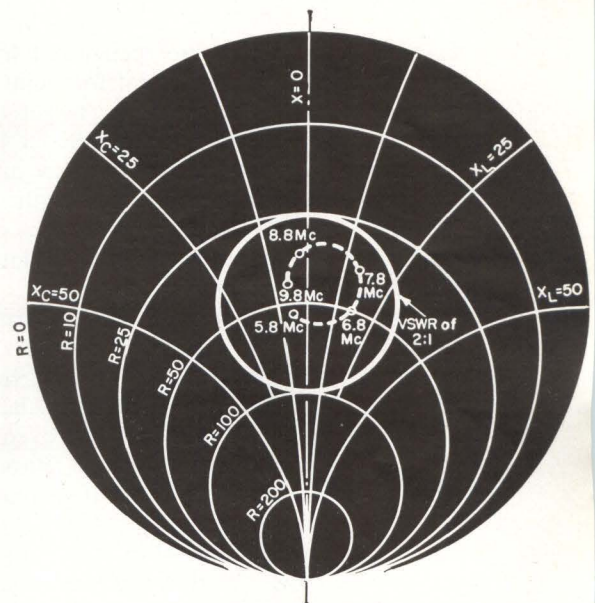

MEASURED input impedance of 5.5 to 11-Mc filter, multicoupler terminated in 50-ohm resistive load, remaining filters are detuned at least 0.7-Mc—Fig. 3

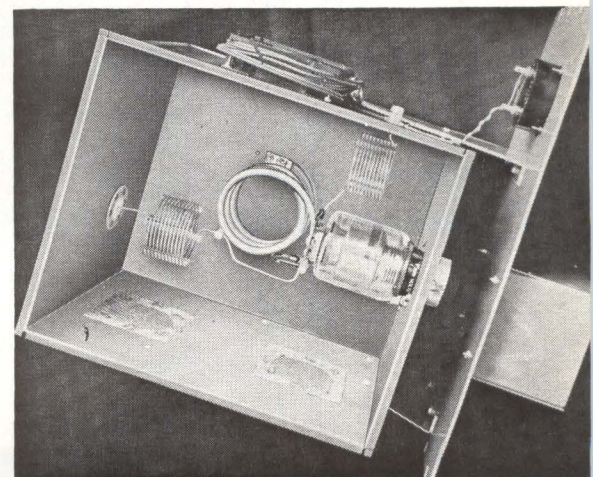

SINGLE multicoupler filter handles one 600-w transmitter over an octave



# INJECTION-LASER SYSTEMS for Communications and Tracking

Injection lasers can now be applied advantageously in some communications problems and may well be the system of choice for space missions. Possibilities for high precision radar tracking are also excellent but more work is needed in this area

By C. M. JOHNSON, IBM Federal Systems Division, Bethesda, Md.

**LASER SYSTEMS** were recognized from the beginning as having high potential for point-to-point communications and for precision target tracking. The injection laser, being essentially a semiconductor diode, is at present the simplest way of realizing such systems. Between the concept and the actual system, however, lie the engineering problems of power level, bandwidth, modulation and demodulation, frequency stability, signal acquisition and noise.

After a year of research on materials and fundamental properties of injection lasers, some useful coherent light sources are now being tested in experimental communications links. Other applications are awaiting further device improvements, such as increased output power at room temperature, operation at visible wavelengths, and increased coherence.

**Laser Communications**—For point-to-point communications systems at ultra-high information rates or where extreme privacy (or noninterference) is demanded, lasers offer significant advantages over radio systems. Injection lasers, because of their high efficiency, direct electrical stimulation, and ease of modulation, presently appear better suited to communications applications than other types.

Point-to-point communications should be emphasized since laser systems are at a prohibitive disadvan-

tage to radio systems for wide angle or omnidirectional coverage. Transmitter power required for a communications link where the receiver is quantum noise limited and the antennas are diffraction limited is

$$P_T = \frac{16 R^2 hcB \rho \lambda}{\pi^2 D_T^2 D_R^2 \eta L_a L_r} \quad (1)$$

[where  $P_T$  is peak transmitter power,  $R$  is range to target in meters,  $h$  is Planck's constant,  $c$  is speed of light meters/sec,  $\lambda$  is radiation wavelength in meters,  $\eta$  is the quantum efficiency of the detector,  $B$  is twice the video bandwidth of the receiver in cps or  $B = 1/\tau$  (where  $\tau$  is the observation time),  $D_T$  and  $D_R$  are diameters of the transmit and receive antennas respectively in meters,  $\rho$  is the signal to noise ratio or number of signal photo electrons for a quantum limited detector,  $L_r$  is transmission factor of the optical system, and  $L_a$  is transmission factor of the atmosphere.]

Required transmitter power increases linearly with wavelength for constant diameter antennas, or correspondingly, the attainable range increases as  $\sqrt{1/\lambda}$ . Thus, for a quantum noise limited receiver, an optical system will have more than one hundred times the range of a microwave system for the same transmitter power. For the same antenna diameter, the beamwidth

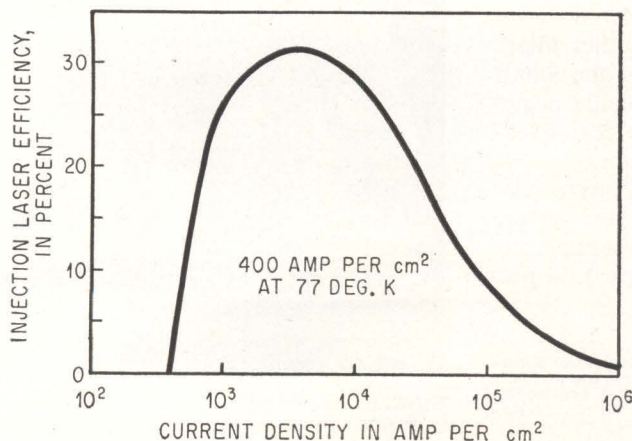

## PUTTING LASERS TO WORK

Lasers are beginning to look as if they belonged. Lasers, now five years old, are beginning to be applied to all kinds of problems. They are being tested for curing cancer, they are being applied in delicate surgery, and they may yet be used as a wireless technique for supplying power at long distance. But the first workhorse job for lasers is apparently going to be communications and precision target tracking. When atmospheric conditions are favorable, lasers can supply bandwidth and resolution to make old-line radar-radio engineers envious

▲ CALCULATED EFFICIENCY of GaAs injection lasers for typical operating conditions is maximum from 10³ to 10⁴ amps per cm²—Fig. 1



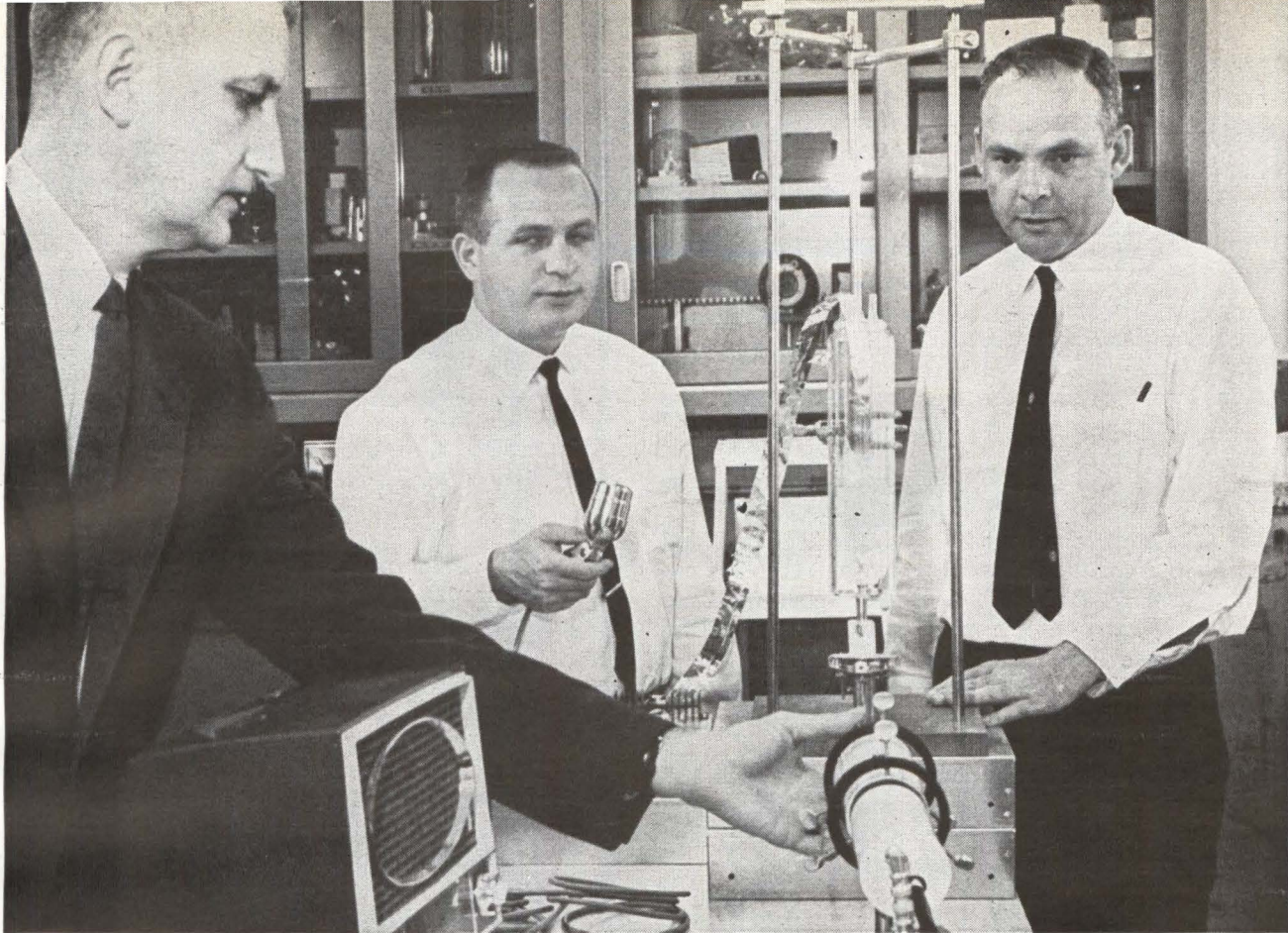

FROM LEFT to right, C. M. Johnson, K. E. Niebuhr and R. C. Green experiment with injection laser system for transmitting audio signals. Optical receiver is being aligned with laser transmitter

of an antenna at optical frequencies is orders of magnitude less than at microwave frequencies. Consequently the price for increased range is increased difficulty in signal acquisition and tracking. In many cases, however, acquisition and tracking can be done either visually or with an image converter system, thereby largely overcoming the narrow-beam difficulty.

**Bandwidths**—If transmit and receive beamwidths,  $\phi_T$  and  $\phi_R$ , are held constant

$$P_T = \frac{\pi^2 hc \rho R^2 (\phi_T)^2 (\phi_R)^2}{16 \lambda^3 \eta L_a L_r} \quad (2)$$

where  $D^2 = (16/\pi^2) (\lambda^2/\phi^2)$  has been substituted in Eq. 1.

Under this constraint the required transmitter power for an optical system is much greater than for a microwave system:  $P_T \approx 1/\lambda^3$ . Thus, unless effective use can be made of narrow beamwidths—that is, unless the system is aperture limited rather than beamwidth limited—an optical system is prohibitively expensive in transmitter power compared to a microwave system.

Generally, transmitter beamwidth and diameter of the receiving dish are the controlling parameters in an optical communications system. Consequently, for a quantum noise limited receiver, it is more convenient to use Eq. 1 rewritten as

$$P_T = \frac{P_R R^2 (\phi_T)^2}{D^2 L_a L_r} \quad (3)$$

where

$$P_R = \frac{hc \rho B}{\lambda \eta} \quad (4)$$

It should be emphasized that for minimum transmitter power the transmitter beam's angular coverage should be kept as small as compatibility with platform stability and diffraction limit of the available aperture (antenna) will allow. The angular coverage (field-of-view) of the receiving antenna can be made larger than the diffraction limit of the aperture without loss of antenna gain (that is, without increasing required transmitter power). The increase in noise background because of this greater angular coverage, however, places a limit on the receiver field-of-view.

**Usable Signal**—Superheterodyne optical receivers are not at this time suitable for a communications system because of the stringent stability requirements on the optical local oscillator. In addition, by using coded modulation techniques, an optical envelope detector can approach the quantum limit in sensitivity.

Minimum detectable signal of an optical receiver of the envelope type (multiplier phototube) is<sup>16</sup>

$$P_R = \frac{h\nu\rho B}{\eta} \left[ 1 + \left\{ 1 + \frac{4KT_0(F_v - 1 + t_e) + 2\epsilon i_D R_L}{\epsilon^2 R_L \rho B} \right\}^{1/2} \right] \quad (5)$$

[where  $K$  is Boltzmann's constant,  $F_v$  is the noise figure of the video amplifier following the photodetector,  $T_0$  is the standard reference temperature,  $t_e$  is the normalized equivalent noise temperature of the resistive output of the detector,  $\epsilon$  is the charge of an electron,  $i_D$  is dark current of the detector,  $R_L$  is output resistance of the detector, and  $\eta$  is the signal frequency ( $\eta = c/\lambda$ ).]

When system bandwidth is relatively small or back-



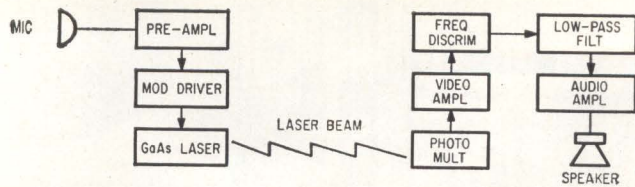

VOICE CHANNEL of 4-kc was transmitted with this system, using pulse frequency modulation—Fig. 2

ground noise or detector dark current is high, the minimum signal is

$$P_R = \frac{h\nu}{\epsilon \eta} \left[ 2eI_D \rho B \right]^{1/2} \quad (6)$$

In this case quantum noise has been neglected and also noise from the following video amplifier.

If system bandwidth is increased, quantum noise increases relative to the shot noise level given by Eq. 6. Then, from Eq. 5, a bandwidth exists where all except quantum noise can be neglected, and in this limit  $P_R$  is defined by Eq. 4.

**Pulse System**—Thus noise characteristics are such that a pulse system can be used to minimize average transmitter power for a given information channel. This advantage results from the fact that

$$P_{avg} = P_T \tau f_R = \frac{P_T f_R}{B} \quad (7)$$

where  $\tau$  is pulse length and  $f_R$  is pulse repetition rate. If Eq. 6 is substituted for  $P_R$  in Eq. 3, the required transmitter power for a given signal to noise ratio is found to be proportional to  $\sqrt{B}$ , and if the system is operated pulsed this corresponds to the peak pulse power required. If this proportionality is then substituted into Eq. 7

$$P_{avg} \approx 1/\sqrt{B} \approx \sqrt{\tau}$$

Consequently, for a constant information rate, determined by  $f_R$ , the average power decreases as the pulsewidth decreases until the receiver becomes quantum noise limited—that is, until the minimum required power is limited by a minimum number of photons per pulse, rather than by other system noise. At this point the average power becomes independent of system bandwidth.

## INJECTION LASERS TODAY

By far the most fully developed injection laser is the gallium arsenide (GaAs) type,<sup>1,2,3</sup> which operates at wavelength of 8400 Å when cooled to 77 degrees K. However, at this time five other semiconductor materials, namely indium arsenide<sup>4,5</sup> (InAs), indium phosphide<sup>6</sup> (InP), gallium phosphide arsenide<sup>7</sup> (GaPAs), gallium indium arsenide<sup>8</sup> (GalnAs), and indium antimonide<sup>9</sup> (InSb) have been successfully operated as injection lasers, and a silicon carbide device has been announced. Of course, many other semi-conductors of the III-V and II-VI groups give off incoherent recombination radiation. (At this time evidence indicates that the narrow band emission observed from silicon carbide is not due to stimulated emission.) The wavelength coverage of available injection lasers now extends from 6,500 Å to 5.2 microns. Although lasers could be constructed from alloys such as Ga(P<sub>x</sub>As<sub>1-x</sub>), where x is the percentage of phosphorous, to give continuous coverage over

**Transmitter Power**—With all the above factors considered, and on the basis of a background noise limited system, the average transmitter power required for an optical communications system is

$$P_{avg} = \frac{f_r \phi T^2 R^2}{L_a} \times \sqrt{\frac{4 \rho h \nu b \omega \Delta \lambda}{\pi \eta D_R^2 L_r B}} \quad (8)$$

where  $b$  is the background radiance (watts/m<sup>2</sup>-sterad- $\mu$ ),  $\omega$  is the optical receiver field-of-view (sterad.), and  $\Delta \lambda$  is the optical bandwidth (microns).

When all noise sources except quantum noise can be neglected, the average transmitter power is

$$P_{avg} = \frac{f_r \phi T^2 h \nu}{D_R^2 L_a L_r} \ln \left( \frac{1}{1-p} \right) \quad (9)$$

where  $p$  is the probability of detection, which is related through a Poisson distribution function to the number of signal photoelectrons  $\rho$

$$p = 1 - e^{-\rho} \quad (10)$$

$$\text{or} \quad \rho = \ln \left( \frac{1}{1-p} \right)$$

Thus pulsed operation brings an envelope detection system to the quantum sensitivity limit. In addition, pulse operation permits use of efficient modulation techniques such as pfm (pulse frequency modulation) or pcm (pulse code modulation), for additional noise suppression in the demodulation system. Also, constant amplitude pulse modulation makes it possible to operate an injection laser at its most efficient current level at all times. Although pulsed modulation offers the foregoing advantages, the injection laser is also well suited to analog amplitude modulation since light output is a linear function of current input.

**Efficiency**—For optimum efficiency, current  $I$  through the injection laser should exceed the threshold current  $I_t$  (where lasing action begins) by a large factor but should not cause excessive  $I^2 R_d$  losses in the diode, where  $R_d$  is the series resistance of the diode. Specifically, the efficiency of an injection laser is

$$e = \frac{\eta \beta (I - I_t)}{I + I^2 R} = \frac{\eta \beta (J - J_t)}{\beta J + \rho I J^2} \quad (11)$$

where  $\eta$  is the external efficiency for light generation,  $\beta$  is a conversion factor which depends on the band

a wide spectral region, in actual fact only a few spot wavelengths have been reported in the literature; GaAs at 8400 Å (77 K) and 9,000 Å (room temperature), InAs at 3.1 microns (77 K), InP at 9,000 Å (77 K), GaPAs at 7,100 Å (77 K), GalnAs at 207 and 1.77 microns (1.9K), and InSb at 5.7 microns (1.7K). Although both GaAs and InAs lasers have been operated c-w at liquid helium temperature (4.2 K), only the GaAs type has been operated c-w at liquid nitrogen (77 K), and none except GaAs has been operated at room temperature. However, there is no fundamental reason why lasers such as the InP and InAs types cannot be operated similarly. At present, however, their lasing thresholds (required current density) are much higher than the threshold for GaAs. It is probable that these higher thresholds only indicate that more materials research has gone into GaAs. Present lasing thresholds for Fabry-Perot type GaAs injection lasers are typically 1,000 to 2,000 amps per cm<sup>2</sup> at 77K, although values as low as 400 amps per cm<sup>2</sup> have been realized.<sup>10</sup> Thresholds are even lower for the non-directional, total internal reflection



gap of the material (approximately 1.5 w per amp for GaAs),  $J$  is current density,  $\rho$  is resistivity of the material, and  $L$  is the thickness of the wafer. Figure 1 shows a calculated efficiency function for present typical injection lasers, assuming  $\eta = 0.4$ ,  $\rho = 10^{-2}$  ohm-cm,  $L = 0.5 \times 10^{-2}$  cm, and  $J_t = 400$  amp per  $\text{cm}^2$ . Current densities between  $10^3$  and  $10^4$  amps per  $\text{cm}^2$  give close to maximum efficiency.

**Injection Laser System**—An experimental injection laser communications system, Fig. 2, was developed and tested at the IBM Communications Laboratory by K. E. Niebuhr and R. C. Green with pulse frequency modulation to transmit a 4-kc voice channel.

The modulation circuit, Fig. 3, consists basically of a delay line whose charge time can be controlled. When the voltage of the delay line reaches a pre-set level a four-layer diode at the end of the line breaks down, discharging a 0.1-microsecond, 5-amp pulse through the laser. Charge time of the delay line, and therefore the frequency of the laser pulse train, is controlled through a variable resistance element by the amplitude of the information signal. In this experiment the laser transmitter emitted 0.2-watt pulses at an average repetition rate of 12 kc. The principal problem involved in the modulator was to match the half-ohm (or less) impedance of the laser.

The optical receiver consists of a small receiving telescope, with a 4-cm objective and an adjustable field-of-view, illuminating the photocathode of an RCA 7102 multiplier phototube. Output of the multiplier phototube is fed into a 5-Mc bandwidth video amplifier, and the output pulses from the video amplifier are fed into a single shot multivibrator, which generates pulses of standard amplitude and width and sends them to a low-pass filter. Output of the low-pass filter is an audio signal whose amplitude is proportional to the pulse repetition rate.

The laser in the above system, shown in the photographs, was operated in a liquid nitrogen bath with considerable bubbling around the laser. No modulation distortion was detected from the bubbling even though the amplitude of the output signal pulses varied by at least 100 to 1. The natural  $1 \times 15$  degree beam (nominal) of the laser was used without any additional beam shaping optics and both transmitter



FOIL LEAD from modulation equipment is being attached to injection laser. Top of dewar for liquid nitrogen cooling is at bottom

and receiver were battery powered.

Without bubbling and without atmospheric attenuation, the system has a range of about one mile. (Bubbling can be eliminated by mounting the laser on a heat sink outside the coolant). If the transmitter beam were reduced to  $10^{-3} \times 10^{-3}$  radians and a 2-ft collector dish were used at the receiver, the range would be about 600 miles.

**Satellite Link**—To illustrate the requirements on a GaAs injection laser in an operational system, consider a hypothetical 5-Mc bandwidth link between a satellite and a ground station. Here the maximum slant range would be about 1,500 miles at low eleva-

types.

Power output and efficiencies of injection lasers are strongly dependent on temperature. In liquid hydrogen (20 K) more than a watt c-w has been reported.<sup>11</sup> At liquid nitrogen (77 K) milliwatt level c-w operation has been reported,<sup>12</sup> and peak pulse power (low duty cycle) of about 100 watts<sup>13</sup> has been obtained. At room temperature, c-w operation has not been obtained but peak pulse power of at least 6 watts has been realized.<sup>14</sup> In the pulse mode of operation rise times of a few nanoseconds have been observed on GaAs injection lasers.

At 77 K external quantum efficiencies (photon output versus electron input) of 60 percent have been measured for the best diodes with run of the mill values being around 40 percent. At room temperature external quantum efficiencies of 15 percent have been measured. The total overall efficiency (d-c to light output) is reduced from the above values by the ohmic losses in the diodes; however, values greater than 10 percent at 77 K are readily obtainable.

Efficiency is one of the principal advantages of a lasing GaAs diode over a nonlasing diode. Due to the relatively high index of refraction of GaAs, the total internal reflection angle is small (about 14 degrees) and most of the radiative recombination energy generated is dissipated by multiple reflections in the diode itself. On the other hand, in a lasing diode most of the light propagates normal to the laser end faces, and consequently escapes from the device without being totally internally reflected. The maximum external quantum efficiency obtainable from a nonlasing diode at 77 K is about 11 percent, and this value is only obtainable with specially shaped surfaces.

Reliable linewidth measurements have not yet been made on GaAs. In all cases reported in the literature, the values are spectrometer limited. A realistic measurement will have to await development of a suitable heterodyne technique. From the highest resolution measurements<sup>15</sup> and from theoretical considerations it appears that linewidths of the order of kilocycles are realizable at stimulation levels well above threshold



tion angles. Expected atmospheric transmission at 0.9 micron is about 25 percent for such a path, and minimum transmitter beamwidth with automatic tracking is about  $2 \times 10^{-4}$  radian. For convenient acquisition and tracking the ground receiver should have a minimum field of view of about  $10^{-6}$  steradian. An optical filter bandpass of about 10 Å ( $10^{-3}$  micron) is a reasonable practical assumption, giving an overall optical transmission factor for the receiver of about 25 percent. At 0.9 microns the photon energy  $h\nu$  is  $2.2 \times 10^{-19}$  joule, and the quantum efficiency of an S1 photocathode at this wavelength is  $3 \times 10^{-3}$ . A reasonable value for daytime sky radiance is about 10 w per  $m^2$ -steradian-micron. The receiving dish could be as large as 5-ft in diameter (1.5 meters) since astronomical precision is not required; that is, the dish is principally a signal collector rather than a precision signal resolver. For a 5-Mc information channel the pulse repetition frequency for a pfm system must be at least 10 Mc to assure adequate Nyquist sampling. A pulse width of 2-ns will be assumed.

If the above numbers are substituted into Eq. 8, required average transmitter power is 8-mw. Since the duty cycle is  $2 \times 10^{-2}$  the peak transmitter power must be 0.4 watt.

If the numbers are substituted into Eq. 9 instead of into Eq. 8, and 0.999 probability of detection is assumed, the required average transmitter power becomes 9-mw or 0.9 watts peak. Since this transmitter power is greater than that calculated on the basis of background noise, the system is quantum noise limited by a small factor.

**Readout**—Fast readout to a ground station of picture information collected by a satellite is an application well matched to the characteristics of the link described above.

Such a system might require an information bandwidth of a few hundred megacycles, and digital modulation appears most suitable because of the large available bandwidth in the optical region. To be compatible with extremely short pulses required to achieve this information capacity the receiver would be of quantum noise limited even for a relatively wide field of view. Consequently, a large, moderately precise receiving dish can be used at the ground station.

Tracking from the satellite can be accomplished with a laser beacon mounted on the ground receiver tracking pedestal. In addition to its narrow spectral width the ground beacon could also be modulated or coded to provide additional discrimination and security. If this communications system requires a 200-Mc bandwidth, and other systems parameters are the same as for the 5-Mc bandwidth example given above, required average transmitter power is 0.3 watt. Such a wide bandwidth would require a more complex modulation scheme than for the 5-Mc channel.

At 1,500 miles the  $2 \times 10^{-4}$  radian transmitter beam would subtend an arc of only 1,500 ft; thus the system has a high degree of privacy. Dense cloud cover or comparable atmospheric disturbances would interfere with transmission, but ground stations can be located where the cloud cover is minimum and occurs during the year at predictable times. Also,

multiple ground stations can be provided.

**Astronaut Link**—Another promising application is a link between astronauts and a space station. In this use an injection laser operating in the visible spectrum would make an extremely compact, efficient transmitter, while acquisition and tracking could be done visually. A small photodiode, a centimeter diameter lens and demodulation circuits would make an adequate receiver.

A third application is communicating between different parts of a space station, useful if the station consists of several parts loosely coupled. In addition to small size and low power drain, such a system would not interfere with radio and microwave links nor with space station radars.

All the above applications are presently realizable with available injection lasers and optical devices. However, it is not possible to use a laser operating at room temperature for the large bandwidth cases illustrated. Although the required peak powers can be realized at this time at room temperature, the required duty cycles are too great.

**Laser Tracking**—Advantages of laser tracking systems over radar systems are better angular and velocity resolution. But acquisition is more difficult except where human eyes can be used.

Optical and radar systems can be compared by tailoring the radar equation to include optical systems. To a large measure the comparisons made on communications systems also hold for radar systems. Peak transmitter power for an optical radar system with a quantum noise limited receiver is

$$P_T = \frac{\pi^3}{4} \cdot \frac{\rho \phi T^2 \phi_R^2 R^4 h c B}{\sigma \lambda^3 \eta} = \frac{64}{\pi} \cdot \frac{R^4 h c B \lambda}{\sigma D_T^2 D_R^2} \quad (12)$$

where  $\sigma$  is the backscattering cross section of the target; other quantities are as defined for Eq. 1.

From Eq. 12, for equal beamwidths, required transmitter power for equal signal detecting probabilities and constant scattering cross section is proportional to  $1/\lambda^3$ . This result implies receivers with equal quantum efficiencies in the wavelength regions being compared, such as, for example, a microwave maser and a cooled multiplier phototube.

An optical radar compares much more favorably with a microwave radar if antenna diameter rather than beamwidth is the limiting factor. Then  $P_T \approx \lambda$ .

**Scanning**—If optical and microwave beam scanning systems with equal antenna diameters are compared, according to Eq. 12, it can be shown that the average transmitter power,  $P_{avg} = P_T \tau f_R$ , required for equal solid angle coverage with equal detectivity in equal time is proportional to  $1/\lambda$ . This result assumes that pulse repetition rate  $f_R$  is increased for the optical system, according to

$$\frac{f_{R_o}}{f_{R_m}} = \frac{\lambda_m^2}{\lambda_o^2} \approx 10^{10} \quad (13)$$

where  $f_{R_o}$  and  $f_{R_m}$  are the pulse repetition rates for the optical and microwave systems, respectively, and  $\lambda_o$  and  $\lambda_m$  are the respective wavelengths. The solid angle resolution of the optical system is  $10^{10}$  better, but



such an increase in repetition rate is impossible.

More realistically the repetition rate is determined by the range to the target and is constant for either system. In this case the time to scan a given solid angle is proportional to  $\lambda_0^2/\lambda_m^2 \approx 10^{10}$ . For such a condition the optical system would only require  $10^{-5}$  times the power of the microwave system and would give  $10^{10}$  times the solid angle resolution, but the scan time is prohibitively long.

**Antennas**—Generally, for communications systems, transmitter beamwidth and the diameter of the receiving dish are the controlling parameters. Consequently, it is more convenient to use Eq. 12 rewritten as

$$P_T = \frac{4\pi P_R R^4 \phi_T^2}{\sigma D_R^2 L_a L_r} \quad (13)$$

where  $P_R = hc\rho B/\lambda\eta$  for a quantum noise limited receiver. When the system is background noise limited, an expression similar to Eq. 8 can be written for the radar case

$$P_T = \frac{4\pi R^4 \phi_T^2}{\sigma L_a} \sqrt{\frac{4\rho h\nu b \omega \Delta \lambda B}{\pi \eta D_R L_r}} \quad (14)$$

To illustrate the requirements on an injection laser in optical tracking, consider one space vehicle tracking another at 50 miles. Assume the target has an optical scattering cross section of  $100 \text{ m}^2$  ( $3 \text{ mm}^2$  specular reflector), transmitter beamwidth is  $10^{-4}$  radian and receiving dish is 2-ft. in diameter with a  $10 \text{ \AA}$  optical filter;  $L_R$  will be taken as 25 percent. With an S1 multiplier phototube detector and with  $\rho = 10$ , the required peak power at 0.9 micron is about 1 kw.

Transmitter power for the above system could be reduced considerably if a coherent receiver with its higher quantum efficiency were used instead of the photomultiplier detector. For example, coherent detection could be realized if a c-w laser oscillator signal were used as the local oscillator signal on a photomixer detector, as indicated in Fig. 4.

**Resolution**—One possible use of a high resolution scanning system would be to paint a picture of the target vehicle. In addition, if a coherent doppler detection system is used, a high resolution optical system could give rotational velocities. Range, range rate and precise angle to the entire target vehicle can also be measured.

Principal advantages of a doppler measurement system at optical frequencies are precision and speed. At the present time only gas lasers have sufficiently high monochromaticity to give precise doppler measurements. Although most lasers will give orders of magnitude more precise angle measurements than microwaves they lack sufficient monochromaticity for precision doppler measurements. At  $8,400 \text{ \AA}$  a target velocity of 1 ft per sec produces a doppler frequency of 0.8 Mc. It is reasonable to expect that such line width can be realized with GaAs lasers.

Doppler measurement time is also important, and must be long enough to detect the minimum desired increment. For example, if one foot per second velocity increments are to be measured, the optical doppler frequency is about 1 Mc, whereas the microwave doppler frequency is about 100 cps. Thus, the measurement can be made in  $10^{-6}$  second optically,

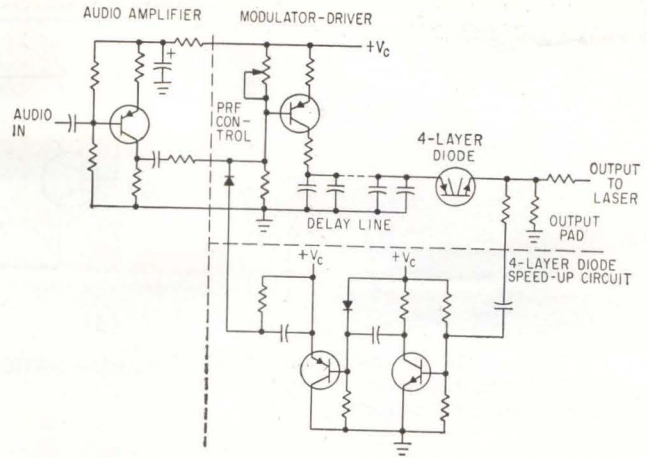

WHEN THE four-layer diode in the modulator-driver breaks down, a 5 amp,  $0.1 \mu\text{sec}$  pulse is delivered to the injection laser. Frequency of the resulting laser pulse train is controlled by the amplitude of the audio input—Fig. 3

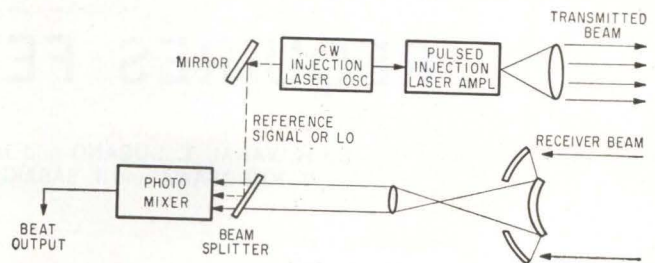

COHERENT OPTICAL radar system has high sensitivity but a limited field of view. Variations of this system might provide actual target outlines or pictures—Fig. 4

but it takes  $10^{-2}$  second with microwaves.

Injection lasers can also be used with ground tracking radars as navigational aids for satellites. A GaAs laser emitting 0.1 joule pulses in a  $10^{-6}$  steradian beam is sufficiently bright for an astronaut using a standard image converter to distinguish from Earth background in full daylight.

At the present time injection lasers have reached the stage of development where they can be used with significant advantage for some communications applications. For radar type applications further development is required on injection lasers, beam scanning techniques, and on photomixing before optical systems can effectively compete with microwave systems.

## REFERENCES

- (1) M. I. Nathan, et al., *Appl Phys Letters* 1, p 64, 1962.
- (2) R. N. Hall, et al., *Phys Rev Letter* 9, p 366, 1962.
- (3) T. M. Quist, et al., *Appl Phys Letters* 1, p 91, 1962.
- (4) I. Melngailis, *Appl Phys Letters* 2, p 176, 1963.
- (5) I. Melngailis and R. H. Rediker, *Appl Phys Letters* 2, p 202, 1963.
- (6) K. Weiser and R. S. Levitt, *Appl Phys Letters* 2, p 178, 1963.
- (7) Nick Holonyak, Jr., and S. F. Bevaqua, *Appl Phys Letters* 1, p 82, 1962.
- (8) I. Melngailis, A. S. Strauss, R. H. Rediker, *Proc IEEE (Correspondence)* 51, p 54, 1963.
- (9) R. J. Phelan, et al., *Appl Phys Letters* 3, p 143, 1963.
- (10) M. Pilkuhn, H. Rupprecht, and J. Woodall, Continuous Emission From GaAs Diode at 77 K, *IBM Research Note* NC-261.
- (11) W. E. Engler, M. Farfinkel, *Solid State Devices*, E. Lansing, Mich., June 1963.
- (12) G. Burns, et al., The Effect of Temperature on the Properties of GaAs Laser, *Proc IEEE (Correspondence)* 51, p 947, 1963.
- (13) T. M. Quist, et al., *Appl Phys Letters* 1, p 91, 1962.
- (14) Recently obtained at IBM.
- (15) P. F. Sorokin, et al., *J Appl Phys* 34, p 2553, 1963.
- (16) C. T. McCoy, Space Communications, *Philco Report* No. 279, Nov. 1958.



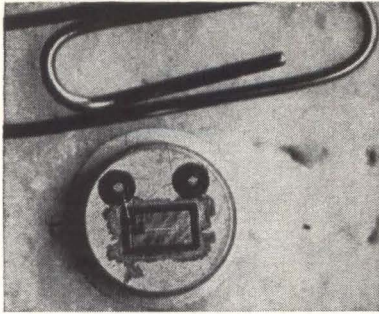

RC OSCILLATOR is constructed with integrated circuit techniques and mounts on a standard TO-5 header

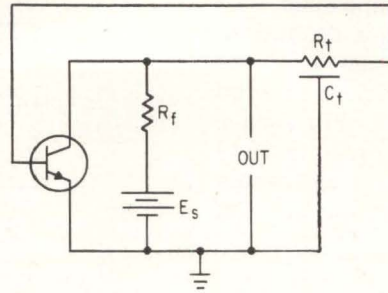

(A)

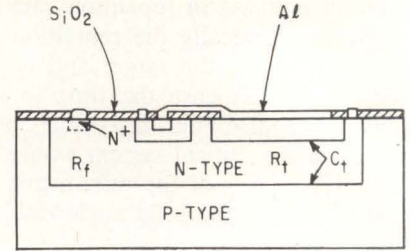

(B)

SCHEMATIC of the oscillator (A), and sectional view of the integrated circuit (B)

# Integrated-Circuit Oscillator REQUIRES FEW COMPONENTS

By H. YANAI, T. SUGANO and M. YOSHIDA, Tokyo University, and  
T. KUROSAWA and I. SASAKI, Nippon Electric Company, Tokyo, Japan

OSCILLATOR shown in drawing A utilizes a distributed resistance-capacitance transmission line as a phase shifter and a transistor as an amplifier. Stable oscillation can be obtained when the sum of the phase shift due to the transistor and that from the RC line is an integral multiple of  $2\pi$ . Oscillation is maintained as long as sufficient energy is supplied through the feed resistance.

**Design**—The monolithic integrated circuit of the oscillator is useful from viewpoints of size reduction, economy, and reliability. A sectional view of the integrated circuit appears in diagram B. This circuit is simple and requires a minimum number of components.

Resistors  $R_t$  and  $R_f$  are formed using the bulk resistance common to the transistor collector body, rather than by using a conventional  $p$ -type diffused layer. These resistors are convenient to use because they require no interconnection. If a spreading resistance is available for  $R_f$ , construction may be even simpler. However, it is difficult to use this resistance because of the resistivity of the wafer. Capacitor  $C_t$

is formed by  $pn$  junctions surrounding resistor  $R_t$ . Transistor characteristics are similar to those 2SC31. Ohmic contacts can be attached to the  $n$ -type region by evaporating aluminum after diffusing phosphorus into the contact areas.

**Construction**—Seven ohms-cm  $n$ -type silicon is employed as a starting material. After polishing and oxidation, windows are selectively etched on the top surface and boron is diffused in from both the upper and lower surfaces. This process yields  $n$ -type islands that form the transistor collector and resistors  $R_t$  and  $R_f$ . The depth of the  $n$ -region is  $55 \mu$ . Two boron diffused  $p$ -type layers are produced in the  $n$ -region; one serves as the transistor base and the other as the anode of capacitor  $C_t$  together with  $p$ -type bottom. The  $n$ -region between the upper and lower  $p$ -regions forms  $R_t$ .

After phosphorus diffusion for the emitter and contacts to the  $n$ -region, aluminum is evaporated and selectively etched to give a pattern for interconnections and other contacts.

**Performance**—The peak-to-peak oscillation voltage has a maximum value at  $E_s = 14$  volts or  $T = 25$  degrees. This is true because increasing either the supply voltage or temperature shifts the transistor bias point to saturation. Oscillation frequency varies linearly with temperature; it depends upon both the transistor and the transmission line.

The frequency distribution of the circuits fabricated was  $\pm 20$  percent. Another experiment indicated that the oscillation frequency can be varied by applying reverse voltage to junction capacitor  $C_t$ . This suggests that the circuit is suitable for f-m use.

## TRULY SIMPLE DEVICE

This oscillator represents an ultra-simple circuit that achieves small size through use of integrated-circuit techniques. It is versatile and offers economy and reliability at both high and low frequencies. Moreover, it is suitable for f-m applications if designed in a somewhat different form. This redesigning is necessary because the frequency-determining line and the collector portion of the transistor overlap so that a change in voltage on the line changes the collector voltage. For f-m use, the frequency determining line must be set off by diffusion isolation



# Microwave Associates at Ka-BAND

a  
complete  
capability

## **Semiconductors**

Microwave Silicon Mixer  
and Video Detector diodes.  
Varactor Diodes.

## **Waveguide Components**

Attenuators. Loads. Waveguide  
Switches. Pressure Windows.  
Waveguide Accessories. Power  
Dividers — many types.  
Detector Mounts. Antenna  
Components. Circular Waveguide  
Components. Waveguide Castings.  
Standard Mixers. Microwave  
Shutters.

## **Tubes and Duplexers**

TR Tubes for all power and  
environmental conditions.  
CW and pulsed  
Beacon Magnetrons.  
Ferrite Duplexers.

## **Solid State**

Semiconductor  
SPST Waveguide Switches.  
Ferrite Duplexers.  
Low Power narrow band  
Power Sources. Broadband  
frequency amplifier/multiplier  
Harmonic Generators.  
High & Low Power  
Ferrite Isolators,  
Circulators & Circulator Switches.

## **Instruments & Assemblies**

Waveguide Assemblies and  
Subsystems fully proven in our  
own high power test facilities.  
Microwave Test Equipment.  
Research & Development.

Products available at VHF, UHF,  
L, S, C, X, Ku and Ke Bands.



**MICROWAVE  
ASSOCIATES, INC.**

BURLINGTON, MASS. • WESTERN UNION FAX  
TWX: 617-272-1492 • TEL: 617-272-3000

Oversas Sales: Microwave Associates International, Inc.  
Burlington, Massachusetts

United Kingdom Sales: Microwave Associates, Ltd.  
Cradock Road, Luton, Beds, England





## avoid guesswork

... when you're specifying important high-vacuum components. Put two decades of VEECO experience and reputation to work for you; discover the advantages of the highly successful VEECO value formula:

- **QUALITY** — specify VEECO for components which are thoroughly checked in the plant before being shipped to you.
- **RELIABILITY** — specify VEECO for components which have been engineered by high vacuum specialists, and used in proven systems for years.
- **DURABILITY** — specify VEECO for components designed for long use.
- **REPUTATION** — specify VEECO for components whose workmanship is backed by one of the most trusted names in high vacuum technology.

Send for our Condensed Catalog and learn more about VEECO's complete line of systems and components including our new TC-DG-9 High Vacuum Controller, our Ionization Gauge and Tubes, our new line of Forged Brass Valves, our Diffusion Pumps, Low-Loss Cold Traps, and BAF Baffles... components which will make your systems work better and longer. Write for your copy today and see for yourself how the guesswork disappears.

**VACUUM-  
ELECTRONICS  
CORP.** 

TERMINAL DRIVE,  
PLAINVIEW,  
LONG ISLAND, N. Y.

May we  
send  
you our  
catalog?

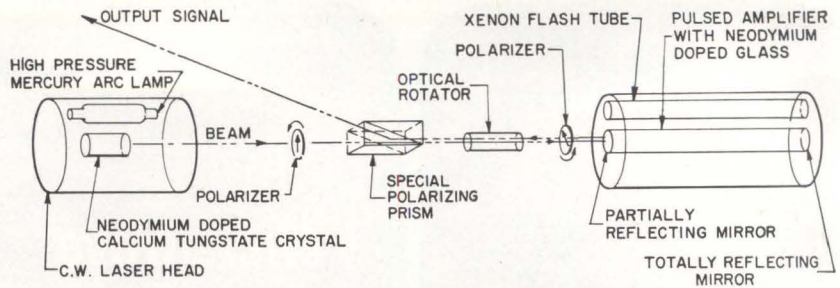

FEEDBACK AMPLIFYING SYSTEM under development would contain and amplify c-w laser's beam, then release it

## Feedback Boosts Laser Beam

Neodymium-doped laser amplifier requires only few watts input power

**LASER AMPLIFIER** that operates on an input signal as low as a few watts was reported last week by Electro-Optical Systems. The company believes the amplifier can lead to development of military surveillance systems.

The amplifier is similar to the ruby-laser amplifiers reported during the past few years (*ELECTRONICS* p 11, Aug. 25, 1961). The coherent beam from one optically pumped laser passes through and is amplified by a second optically pumped rod

with ends that are not silvered.

But, it was reported, the ruby amplifiers required kilowatts of power. Electro-Optical uses neodymium-doped glass, which has a low threshold, for both rods. Gain of the amplifying laser is 7 db. Wavelength of the oscillating laser is 1.06 microns. The laser oscillator can also be a neodymium-doped calcium-tungstate crystal.

**Feedback Amplifier**—The straight-through amplifier is part of a more advanced system that would ultimately use amplifier feedback, the company said. It is believed the feedback configuration (see diagram) will allow greater beam buildup than straight-through meth-

## Baby Laser Is Frequency Tunable

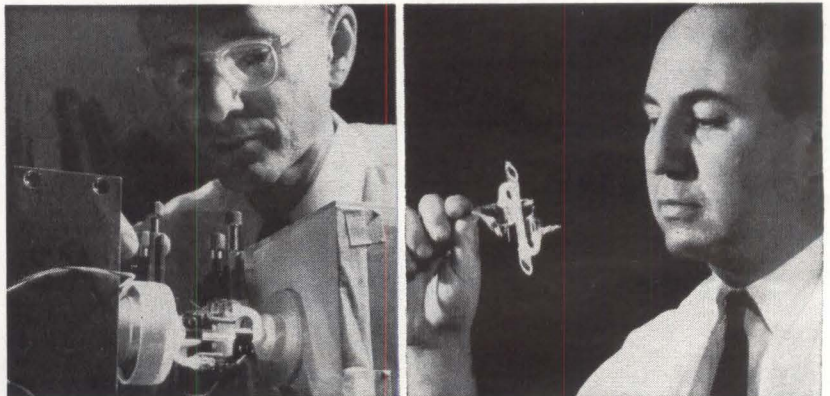

BY REDUCING discharge-tube length to about 2 inches and using an active medium of 7 parts He<sup>3</sup> to 1 part Ne, Bell Telephone Labs has developed room-temperature, c-w, gas lasers that oscillate at single frequencies (*ELECTRONICS*, p 19, Dec. 6). Frequency can be tuned or swept by using piezoelectric crystal to change position of left-hand end mirror (mirrors are in plastic cases). Pump power is 5 ma at 470 v, about 2 w d-c discharge; output totals 0.5 mw; wavelength is 6,238 Å; frequency range is 1.5 Gc centered at 473 Tc. Laser shown has been used as swept-frequency local oscillator. Applications in precision measuring instruments are expected. Developers are A. D. White, left, and E. I. Gordon



ods and provide an output in the order of kilowatts. Pump power seems the only practical limitation, the company said.

The straight-through system employs a pulsed laser oscillator to drive the amplifier. The feedback system employs a c-w oscillator with a neodymium-doped calcium-tungstate crystal operating at a power level of several milliwatts. The arrangement isolates the oscillator from random amplifier-beam reflection. In actual use, it is expected that the neodymium rod will contain and continually reflect oscillator light through an impedance-matching, partially reflecting mirror at the entrance, and a 100 percent reflecting surface at the opposite end. The partially reflecting surface allows the input light to enter the neodymium rod but then traps it to give heavy beam buildup before permitting it to emerge.

In combination with a laser phase shifter and power divider, Electro-Optical believes the amplifier could eventually be used as part of a rapid-scan surveillance system with a single laser oscillator. It could also be used in the power source of laser systems for deep-space tracking and detection.

The amplifiers are being developed under contract to the Air Force Systems Command, Rome Air Development Center.

## Nuclear Instruments Near Picosecond Working Speed

PARIS—Nuclear research instrumentation is at the threshold of picosecond speed, the International Symposium on Nuclear Electronics at Paris, Nov. 25 to 27, revealed.

No one actually announced picosecond hardware, but several papers described time-of-flight analyzers with 1-nanosecond channel width.

That marks a factor-of-10 improvement in the three years since the last meeting.

And as they race for higher circuit speeds, nuclear instrumentation manufacturers can count on a steadily expanding market. French nuclear electronics business amounted to \$20 million last year, including \$3 million in exports.

To turn the corner to picosecond circuits, the tendency is toward in-

# LAPP HEAVY-DUTY ANTENNA INSULATORS

...in all these standard sizes to save you time and money

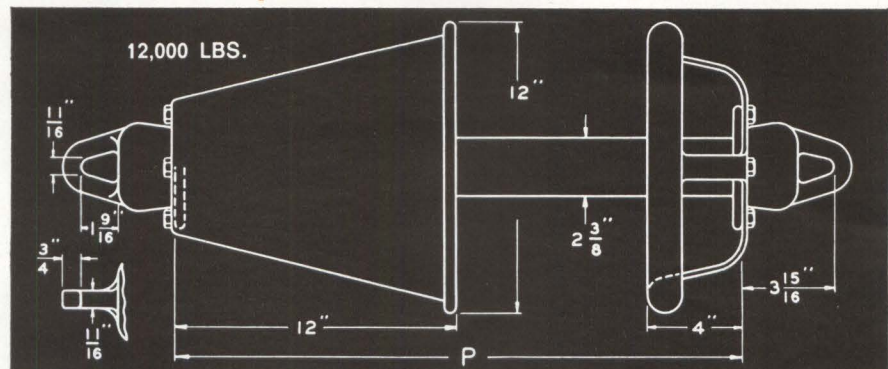

No. 9171, without ring or shield, for most high-strength applications. Standard "P" dimensions: 12, 16, 20, 24, 30 inches.

No. 9172, with two grading rings to raise voltage at which corona starts, and to distribute voltage to reduce heating of porcelain. Standard "P" dimensions: 20, 24, 30 inches.

No. 9173, with corona ring and rain shield, preferred for vertical installations. Standard "P" dimensions: 24 and 30 inches.

9,000 and 10,500 LBS.

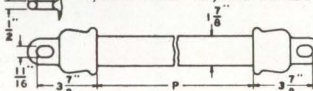

No. 43812 in porcelain (rated at 9,000 lb. average ultimate strength) or No. 43813 in steatite (10,500 lbs.), in standard "P" dimensions of 12, 14, 16, 20 inches.

6,000 and 7,000 LBS.

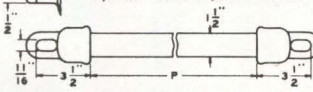

No. 43810 in porcelain (rated at 6,000 lb. average ultimate strength) or No. 43811 in steatite (7,000 lbs.), in standard "P" dimensions of 10, 12, 14, 16 inches.

4,000 and 5,000 LBS.

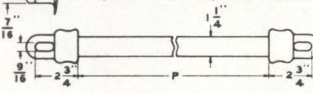

No. 43808 in porcelain (rated at 4,000 lb. average ultimate strength) or No. 43809 in steatite (5,000 lbs.), in standard "P" dimensions of 8, 10, 12, 14 inches.

## FLASHOVER AND RADIO RATINGS

"P" Inches	WET FLASHOVER 60 KV eff.			RADIO RATING KV eff.		
	All except No. 9172 No. 9173	No. 9172	No. 9173	All except No. 9172 No. 9173	No. 9172	No. 9173
8	45			21		
10	54			22		
12	62			23		
14	70			24		
16	77			24		
20	88	88		25	34	
24	96	96	60	27	37	34
30	108	108	108	28	40	38

Steatite Insulators will have the same Flashover but twice the Radio Rating.

# Lapp

WRITE for Bulletin 301-R.  
Lapp Insulator Co., Inc.,  
212 Sumner Street, LeRoy, N. Y.



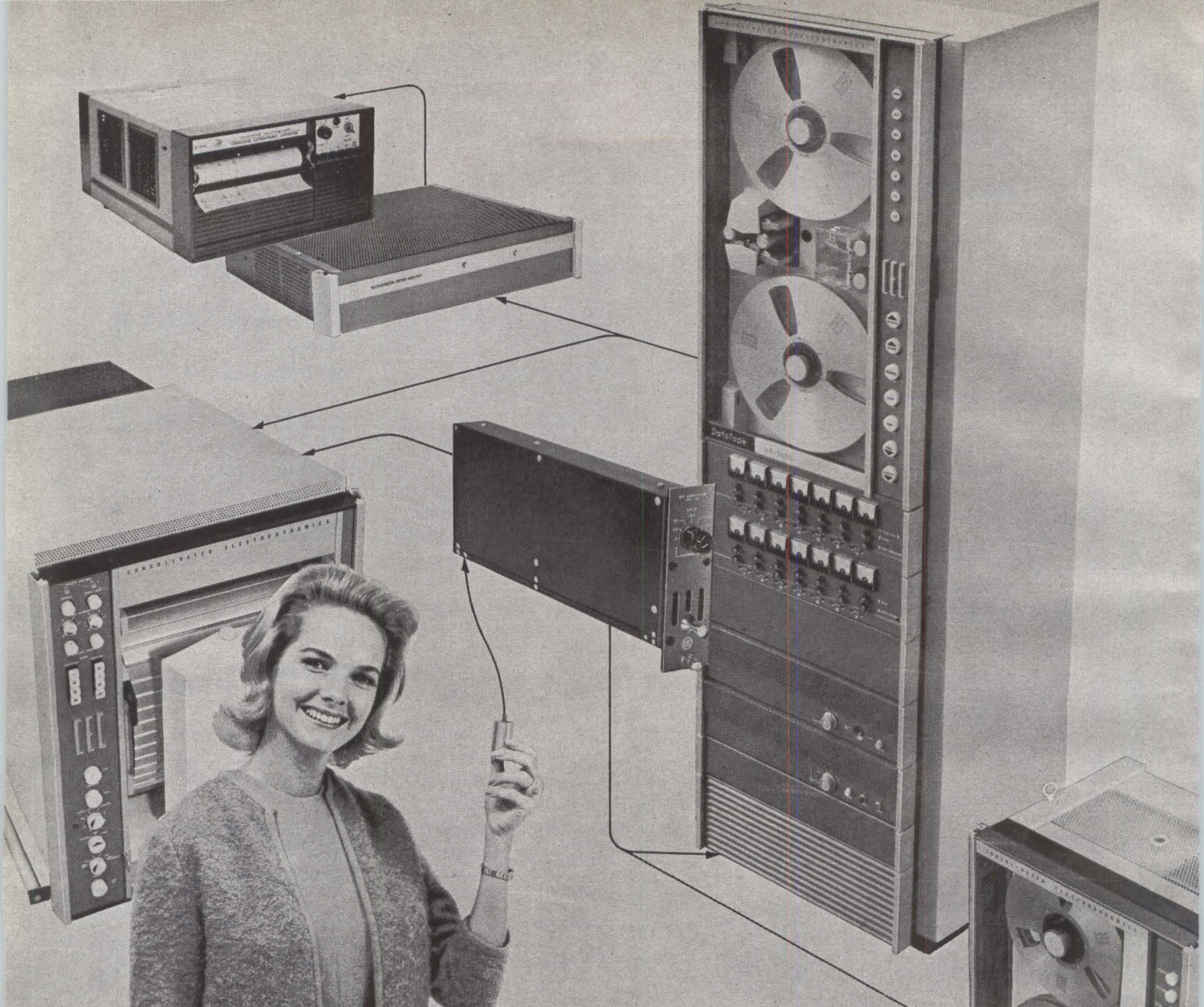

**C**omplete *Instrumentation* in the dynamic data recording field is a CEC exclusive. It covers the state of the art from sensing devices to final readout equipment. The few instruments shown demonstrate a unique understanding of all steps in the art of dynamic recording/reproducing.

**E**ngineering *Excellence* is what goes into complete instrumentation. It shows in the way we design the case for a transducer and in the way the recording heads on the VR-2600 stay aligned. We've worked this way for 27 years. We have learned through experience.

**C**ustomer *Support* from CEC is total support. Service, training, installation, design assistance, you name it. CEC will back you up when and where it counts.

**CEC**

**CONSOLIDATED ELECTRODYNAMICS**  
A Subsidiary of Bell & Howell • Pasadena, Calif. 91109



## New chart to help you



This 21" x 27" wall chart should prove most valuable to anyone concerned with the analysis of static, cyclic or transient phenomena from event to readout.

Each instrument in the four categories shown below is described in detail with basic specifications. There are also cross-reference tables to aid in selecting instrumentation, and information on how to use combinations of the various instruments to meet specific needs. In addition, you will find the finest support equipment for dynamic measuring and recording in industrial and military applications.

### Sensors and Pickups



Chart shows 43 transducers available for pressure, vibration, and acceleration.

### Signal Conditioners

Chart shows 11 basic types and where they may be required.

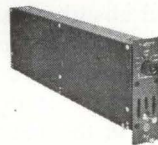

### Magnetic Tape

Chart shows 8 analog and digital recorder/reproducers with support equipment.

### Direct Readout

Chart shows 5 recording oscillographs and 33 galvanometers and where they can be used; also support equipment. Write for your chart today. Request CEC Chart DM-37-X5.



# CEC

**CONSOLIDATED ELECTRODYNAMICS**

A Subsidiary of Bell & Howell • Pasadena, California 91109

CIRCLE 45 ON READER SERVICE CARD  
← CIRCLE 44 ON READER SERVICE CARD

ternational teamwork. At the Paris meeting, for example, the French company Intertechnique and researchers from the German atom research center at Karlsruhe described their jointly developed coder. The minimum channel width is 1 nsec and the maximum number of channels runs up to 17 binary digits. Dead time for analysis is 2 to 300 nsec. The coder obtains an accuracy equivalent to 1 Gc clock time (jitter of 0.5 nsec) by double coding, first to 10 nsec and then by interpolation to 1 nsec. Time and neutron count signals are handled in the same fashion.

**Push to Solid-State**—Nuclear instrumentation makers also are pushing to solid-state hardware. The Intertechnique-Karlsruhe coder uses transistors. A nanosecond coder developed at Euratom's Geel (Belgium) Central Bureau for Nuclear Measurements has tunnel diodes and transistors as its active elements. Tunnel diodes also turn up in a time-of-flight analyzer built at Britain's Harwell establishment.

A researcher from the Chalk River labs of Atomic Energy Limited of Canada reported five standard configurations of Fairchild's direct-coupled-transistor logic had been incorporated into a family of counting circuits. Fastest circuit developed is a binary-coded decimal scale of 10, using 18 elements with 0.15  $\mu$ sec resolution.

Another strong trend underlined at the meeting was automation of physics research. Researchers from CERN reported a crt device to digitize data on spark-chamber film for on-line input to an IBM 7090 computer. Italians, Russians, Germans and Canadians also reported use of computers in experiments.

**Fast Photomultipliers**—An ultra-rapid multiplier photo-tube developed by the French Phillips subsidiary, Laboratoires d'Electronique et de Physique Applique, stirred a mild ripple of interest. With supply voltage of 3 kv, the tube has gain of  $10^8$ . With rise time of 1.5 nsec and electron transit time of  $10^{-10}$ , the tube can detect phenomena with repetition rates faster than 1 nsec. The tube's coaxial cathode pin simplifies the problem of impedance matching to associated measuring instruments.

## OPPORTUNITIES IN MELPAR'S RAPIDLY EXPANDING ELECTRONICS DIVISION

Melpar's Electronics Division has an immediate need for Engineers to fill these important positions:

### MICROWAVE RECEIVER DESIGN

Specific problems include parametric amplifiers, varactor techniques, microwave filters, ultra-stable programmable oscillators, and dual and triple channel balanced receivers for monopulse and guard antenna gating.

### DATA PROCESSING SYSTEMS DESIGN

Perform the logic design of digital equipment to process real time flight data. Problems include specifying necessary digital/analog interface equipment and the design of computer systems for a variety of applications.

### COMPUTER PROGRAMMING

Generate programs for fixed point real time computers to be used with special purpose digital and analog equipment.

### COMMUNICATIONS

Perform design studies of terminal equipments for time frequency dodging, matched filters, adaptive highly reliable communications throughout the electromagnetic spectrum. Techniques of interest include spread spectrum circuitry, error detection and correction coding, and privacy and security circuitry.

For Further Details,  
write in confidence to:

**John A. Haverfield**  
Manager—Professional Placement

**MELPAR INC.**

(A Subsidiary of Westinghouse  
Air Brake Co.)

3436 ARLINGTON BLVD.  
FALLS CHURCH, VA.

(A Suburb of Washington, D.C.)

an equal opportunity employer



# Chemicals Affect Oscillistor Output

Semiconductor research may lead to new ways of analyzing materials

By **DAVID C. T. SHANG**  
Kearfott Division,  
General Precision Aerospace,  
Little Falls, N. J.

**RESEARCH** at General Precision Aerospace Group laboratories has shown that an oscillistor changes its output waveform and frequency when exposed to various chemicals, the change being characteristic of the chemical involved. In addition to the theoretical value of this result, it provides the possibility of an application as a control device for gases such as oxygen, as a gas detector, and also as a chemical analyzer.

The oscillistor effect occurs in a germanium bar subjected to both a magnetic field and a d-c current; given the right conditions such a bar generates oscillations. This effect was discovered by V. I. Stafeev<sup>1</sup> and further investigated by Ivanov and Ryvkin<sup>2</sup>. The latter two authors indicate that an oscillistor changes amplitude and frequency if input current, field intensity, field orientation, illumination or temperature are changed. Several researchers have investigated this<sup>3, 4, 5, 6</sup>.

Certain conditions are mandatory for oscillistor operation<sup>7</sup>: (1) semiconductor material, e.g. germanium, with two contacts, ohmic and rectifying, so that injection of plasma is possible, (2) presence of magnetic field, and (3) direct current passing through the semiconductor.<sup>8</sup> Although one record has indicated oscillation without a magnetic field<sup>9</sup>, this has not been generally confirmed.

Proper orientation of the magnetic field is essential for oscillation; the field must be parallel to the di-

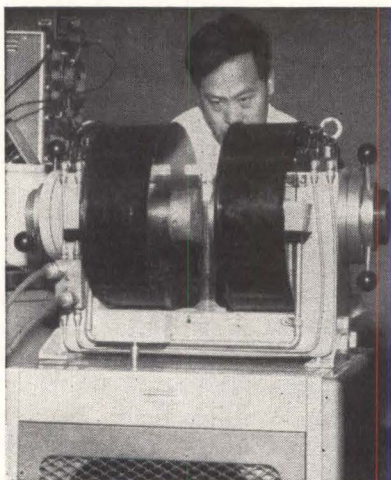

**OSCILLISTOR** in magnetizer, undergoing adjustments by author. Graduate contains chemical in which oscillistor is immersed

rection of current flow<sup>10, 11</sup>. The field must also be within a certain range of intensity; each sample appears to have a different range of magnetic threshold, at present obtainable only experimentally.

Two general theories of the oscillistor have been advanced: (1) Larabee hypothesized in 1960<sup>12</sup> that the oscillistor is a plasma-type device, whose oscillation is due to surface phenomena such as capacitance effect and surface recombination velocity. (2) Using gas-discharged plasma as a basis, Glicksman<sup>13</sup> published a theory in 1961 that oscillation is due to diffusion of ions toward the surface of the semiconductor as a result of the influence of the magnetic field.

**Effect of Chemicals**—The circuit in Fig. 1 was used in the General Precision experiments. The oscillistor sample was placed in a Varian magnetizer. The pulse generator was triggered by an audio oscillator to produce a pulse repetition rate of 7 pps. Pulse length was set to 1.5 ms and amplified to obtain a current up to 200 ma through the sample. Output impedance of the pulse amplifier

was set to 570 ohms. Of the current values tried, 150 ma produced the best results.

The d-c pulse was modulated by oscillations generated in the sample (15 to 40 kc) and picked up across a series resistance, then presented on an oscilloscope. Results were photographed for evaluation. A normal output waveform of the oscillistor in air is shown in Fig. 2A.

**Effect of Liquid Chemicals**—When liquid chemicals are brought into contact with the oscillistor, the resulting frequency differs with each chemical. A hypothesis of this phenomenon follows:

The oscillistor surface is in an excited state, due to diffusion of electrons and holes which are in constant motion from the center of the plasma to the semiconductor surface. If the surrounding environment is air, an exchange of the electrons takes place with air molecules. The exchange process with liquid chemicals should occur even more easily. Since each chemical differs in its rate and quantity of releasing and absorbing surface electrons, the frequency output varies accordingly. The dielectric constant of the chemical may also play a very important part in the reaction; when an oscillistor is immersed in the chemical, its capacitance effect is disturbed<sup>14</sup>.

The oscillistor was exposed to two

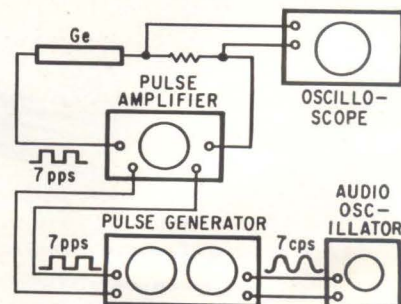

**TEST CIRCUIT** used for measuring effects of chemicals on oscillistor frequency and waveshape—Fig. 1



# KEPCO

REGULATED **WR** DC SUPPLIES



## POWER SUPPLIES WITH EXPERIENCE

Model 1520B



Model 605



Model 430D

The WR Group includes eleven time-proven models from Kepeco's current production of 230 standard models. Kepeco's representatives in your area can supply you with complete technical information, application ideas, and delivery.

### APPLICATIONS:

- ELECTROPHORESIS ■ RADAR
- ELECTROCHEMICAL PROCESSES
- MICROWAVES ■ PHOTOMULTIPLIERS
- COMMUNICATIONS-TELEVISION
- TELEPHONE SYSTEMS
- ELECTRO-MECHANICAL DEVICES

### GENERAL SPECIFICATIONS:

- Input: 105-125 VAC 50-65 cps single phase
- Operating Temperature: -20°C to +55°C
- Temperature Coefficient: <0.01% per °C
- Recovery Time: 50 microseconds
- Isolation: 400 volts (except HB 2050)
- Meters: Voltmeter and Ammeter
- Convection Cooling
- For Relay Rack or Bench Use
- Multiple output and high voltages
- Plate, Grid and Heater Voltages
- Continuously Variable, Zero to full output

See our Complete Catalog in

eem Sec. 4000

PAGES 321-352 eBG



MODEL	DC OUTPUT RANGE		REGULATION				RIPPLE RMS MV	AUX. OUTPUT 6.3VAC Unregulated	PRICE
	VOLTS	MA.	LOAD O-MAX %	LINE ΔV	LINE %	LINE ΔV			
2400 B - #1	0-150	0-5	*	*	*	*	1		\$540.00
#2	0-400	0-150	0.025	0.1	0.1	0.4	3	10 AMP	
#3	0-400	0-150	0.025	0.1	0.1	0.4	3	10 AMP	
400 B	0-400 0-150	0-150 0-5	0.025 *	0.1 *	0.1 *	0.4 *	3 1	10 AMP	270.00
430 D - #1	0-450	0-300	0.025	0.1	0.1	0.4	3	10 AMP	675.00
#2	0-450	0-300	0.025	0.1	0.1	0.4	3	10 AMP	
800 B - #1	0-600	0-200	0.02	0.1	0.1	0.4	3	10 AMP	575.00
#2	0-600	0-200	0.02	0.1	0.1	0.4	3	10 AMP	
605	0-600 0-150	0-500 0-5	0.02 *	0.1 *	0.1 *	0.4 *	3 1	20 AMP	425.00
615B	0-600 0-150	0-300 0-5	0.02 *	0.1 *	0.1 *	0.4 *	3 1	10 AMP	355.00
1250 B	0-1000	0-500	0.01	0.1	0.05	0.4	3		650.00
1220 C	0-1200	0-50	0.01	0.1	0.05	0.4	3	10 AMP	465.00
1520 B	0-1500	0-200	0.01	0.1	0.05	0.4	3		695.00
HB 2050	0-2000	0-500	0.005	0.1	0.02	0.4	3		1565.00
HB 2500	0-2500	0-50	0.005	0.1	0.02	0.4	5		975.00

\*0-150V bias - Regulation: 0.01% Line / 2% Load at 150V

For complete specifications on more than 230 standard model Power Supplies, send for NEW Catalog B-631.



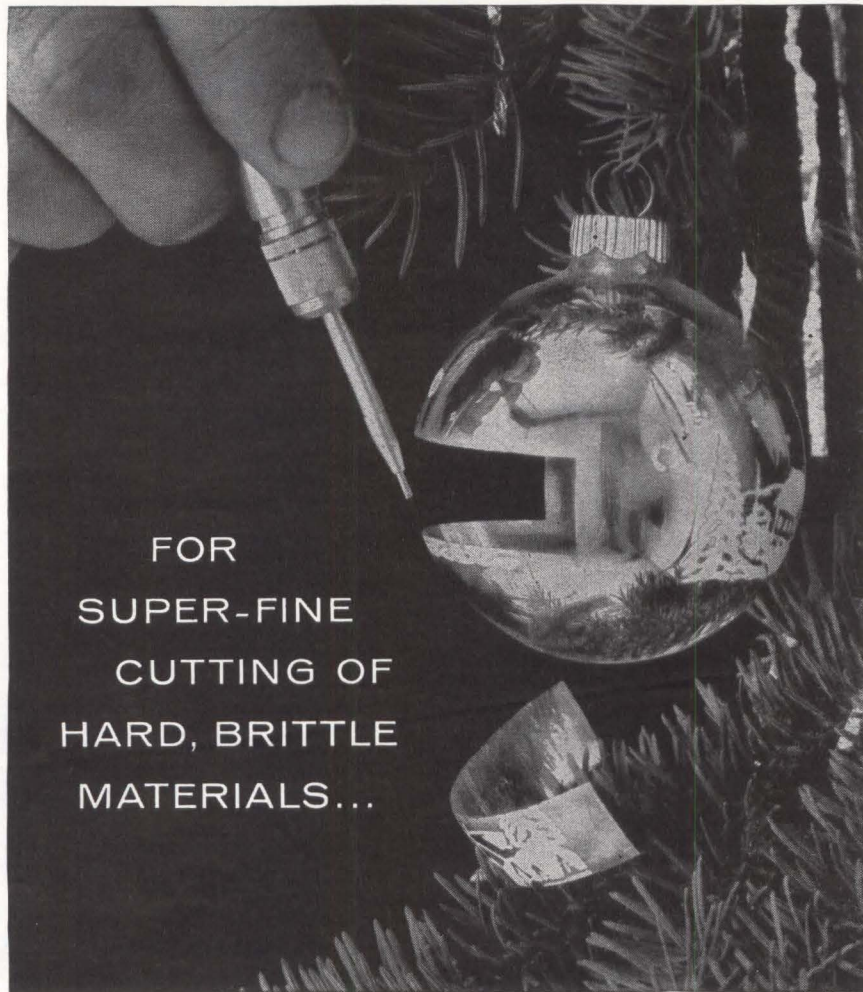

FOR  
SUPER-FINE  
CUTTING OF  
HARD, BRITTLE  
MATERIALS...

## THE *S.S. White* Airbrasive® Unit

It may seem a Scrooge-like trick to slice up this Christmas decoration, but we think you will agree that it is a good demonstration of the ability of the Industrial Airbrasive Unit to cut fragile, brittle materials.

This unique tool is doing jobs that were up to now thought impossible. A precise jet of abrasive particles, gas-propelled through a small, easy-to-use nozzle, cuts or abrades a wide variety of materials such as germanium, fragile crystals, glass, oxides, ceramics, and many others.

Use it to make cuts as fine as .005" . . . or remove surface coatings without affecting base material . . . wire-strip potentiometers . . . deburr precision parts . . . adjust printed circuits . . . in the laboratory or on an automated production line.

Important too: *the cost is low* . . . for under \$1,000 you can set up your own Airbrasive cutting unit!

Send us samples of your "impossible" jobs and let us test them for you at no cost.

WRITE FOR  
BULLETIN 6006.  
Complete information.



S. S. WHITE INDUSTRIAL DIVISION

Dept. EU, 10 East 40th St., New York 16, N. Y. • Telephone MU 3-3015 collect.



groups of liquid chemicals: an alcohol and a benzene group. The waveforms produced by the alcohols are more complex than those due to the benzenes, probably due to the electronic structure of the chemicals.

All chemicals are in a state of electronic resonance. Electrons move from the abundant to the deficient areas. Within an organic molecule, any atom with unshared electrons or a multiple linkage can serve as an electron sink. For example, the double bond of the benzene ring serves as an electron source and the multiple-linked carbon becomes electron deficient. A resonance state due to electron movement is thus created.

The electron moves back and forth from one atom to the other, thus forming its basic nature of stability and reactivity. The diffusion electron of the oscillistor enters the resonance interchange, which in turn affects its oscillation and frequency output.

Mutual exchange of electrons can

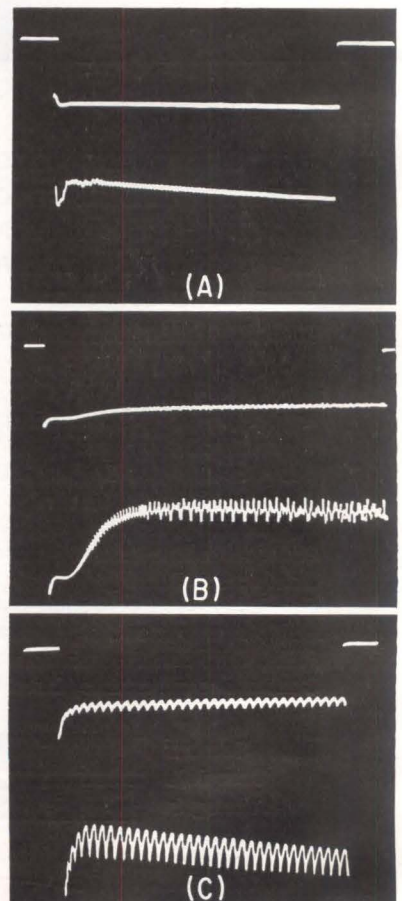

OUTPUT WAVESHAPES of oscillistor in air, (A); in methanol, (B); in hydrogen, (C)—Fig. 2



thus proceed through two basic mechanisms: the active center mechanism and the adsorptive mechanism of the semiconductor surface.

Active center mechanism is the term generally applied in catalysis. Only certain spots of the semiconductor surface are active; the electron exchange takes place through these spots (e.g. hydrogen-platinum).

Any solid substance immersed in liquid or gas will adsorb either. The strong bonding force between them may be expressed as electron sharing. To separate the monomolecular layer of the substance from the semiconductor surface is very difficult. This adsorption effect presumably leads to the disturbances of oscillation, thus generating different frequencies and waveforms.

The results show that an oscillistor operating at a higher frequency is more sensitive to chemicals than one operating at a lower frequency. To analyze chemical compounds, two oscillistors may have to be used, operating at different frequencies.

Paramagnetic substances, such as oxygen, show more change in the frequency output of an oscillistor than diamagnetic substances, such as helium. Thus the oscillistor may be especially useful as a detector for paramagnetic substances.

In tests with various gases, it was found that an electron unsaturated gas affects an oscillistor much more than an electron saturated gas. Such behavior follows the pattern of liquid chemicals in that electron saturation increases the frequency output and electron unsaturation deforms the waveshape of the frequencies.

The author wishes to thank Z. R. S. Ratajski for his encouragement in the work described.

**REFERENCES**

- (1) Ivanov and Ryvkin, *Soviet Phys Tech*, p 772 (1958)
- (2) Ivanov and Ryvkin, *ibid.*
- (3) Pak, J. and Veilax, *Comptes Rendue*, 248, 2,300 (1959)
- (4) Cardone, M. and Ruppel, W., *Phys Rev*, p 1826 (1960)
- (5) Hurwitz, C. E. and McWhorter, A. L., *Quarterly Report on Solid State Research*, Lincoln Laboratories, M I T, Jan. 15, 1961
- (6) Larabee, R. D. and Steele, M. C., *J Applied Physics*, 31, 1519 (1960)
- (7) Larabee, R. D. and Steele, M. C., *op. cit.*
- (8) Ivanov and Ryvkin, *op. cit.*
- (9) Cardone, M. and Ruppel, W., *op. cit.*
- (10) Larabee, R. D. and Steele, M. C., *op. cit.*
- (11) Ivanov and Ryvkin, *op. cit.*
- (12) Larabee and Steele, *op. cit.*
- (13) Glicksman, M., *Phys Rev*, 124, Dec 15, 1961
- (14) Larabee and Steele, *op. cit.*

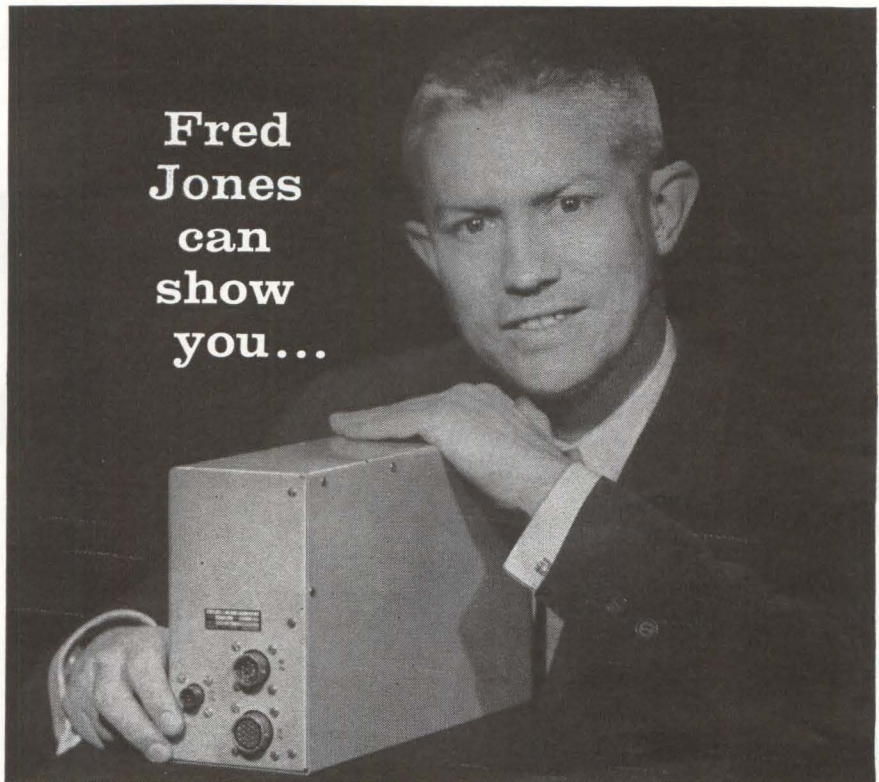

Sales Engineer, Tech-Ser, Inc.

## how to measure in-phase and quadrature with 0.1% accuracy—in milliseconds

Previously unobtainable accuracy and millisecond response are only two of the reasons why NAI's Phase Sensitive AC-to-DC Converters meet the most critical requirements in computer, recording, automatic test and digital display systems.

Unlike conventional converters, these all solid state modules measure not only total signal—but quadrature, in-phase and fundamental components as well. DC output is proportional to selected input component, yet unaffected by harmonics. A wide range of manual and relay-actuated models permits selection and programming of function, range and frequency to suit test or system requirements.

Specifications of relay-programmed models are given in the table. Data on manually switched models PSC-415 and -416 upon request.

	PSC-410/411	PSC-420/421
Voltage Range	(410 & 420)	1 v f.s. to 300 v f.s., 4 ranges
	(411 & 421)	10 mv f.s. to 300 v f.s., 6 ranges
Frequency Range	(phase sens.)	1 frequency*
	(total volts)	3 frequencies*
Linearity	60 cps—20 kc	60 cps—20 kc
Functions	0.1% f.s.	0.1% f.s.
Output Voltage	E <sub>t</sub> , E <sub>f</sub> , E <sub>in</sub> and E <sub>q</sub>	
Input Impedance	0-10 v dc, into 10 k load, for all functions	
Response Time	1 megohm	1 megohm
	0.1 sec	

\*any frequency between 60cps and 10kc.

The North Atlantic man in your area can quickly show you how the PSC-410 and -420 simplify AC measurement jobs from GSE to production test of transducers, networks and amplifiers. Call today for his name, or request Bulletin PSC-1.



**NORTH ATLANTIC industries, inc.**  
 TERMINAL DRIVE, PLAINVIEW, L. I., NEW YORK • Overbrook 1-8600



Your Only Source  
Worthy Of The Name . . .

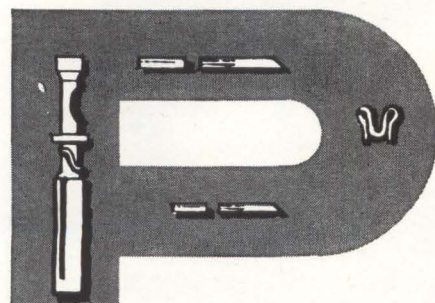

in PRECIOUS

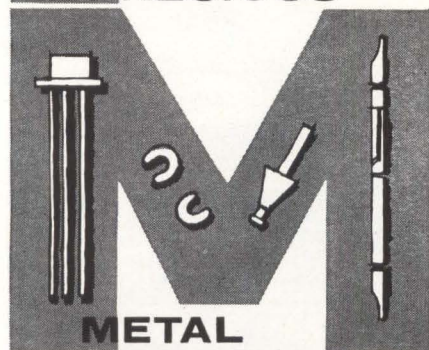

METAL

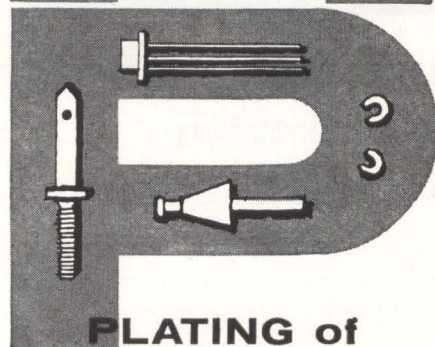

## PLATING of CRITICAL ELECTRONIC COMPONENTS

### ... DEMANDING:

- Purity of deposit
- Completeness of coverage
- Close tolerances
- Tight quality controls
- Rigid inspections

Our experienced staff specializes in high reliability, heat resistant plating with Gold, Silver, Rhodium and other precious metals. Prices on specific applications submitted promptly. Deliveries of completed assignments are on time, too. Write, wire or phone:



**PRECIOUS METAL PLATING**  
DIVISION OF CHEMICAL PLATING COMPANY  
120 Bruce Avenue, Stratford, Connecticut  
Phone: EDison 7-3376 TWX: 203-337-9713

50 CIRCLE 50 ON READER SERVICE CARD

## COMPONENTS AND MATERIALS

# Built-In Diodes Protect Nickel-Cadmium Cells

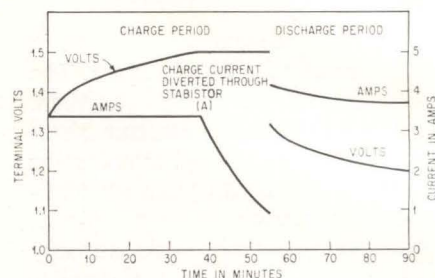
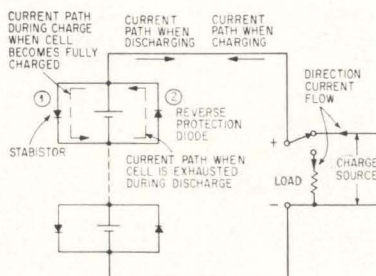

RECHARGEABLE cell uses dual-diode protective circuit (left). System allows series-connected cells to be rapidly charged and safely discharged under all load conditions. Typical duty cycle for a low-altitude space orbit (right) shows stabistor diode diverting excess charge current—Fig. 1

Solve rapid charge  
and discharge problem  
without redesigning cell

**ELMSFORD, N. Y.**—Sonotone Corporation now incorporates two special diodes into their 1.25-v nickel-cadmium cells for fast recharging and deep discharging. Using the system diagrammed in Fig 1 (left), the new cells can be discharged to 70 percent of their capacity and recharged to a usable level in about an hour. Incorporation of the diodes is accomplished without modification of the cell configuration, which was developed jointly by Sonotone and P. R. Mallory and Company, Inc. under a program launched by the U. S. Air Force.

Figure 1 (right) shows a typical duty cycle for a low altitude space orbit. Stabistor diode diverts excess charge current from nickel-cadmium cell at A on the curve.

The rechargeable cells have immediate application in space programs and will be tested to prove stability over much wider temperature ranges.

**Charging**—One diode, a silicon device, prevents current from flowing into a single cell while the battery is

being charged, after the cell terminal voltage has reached a prescribed level. Gas involvement is eliminated with consequent reduction in internal cell pressure and temperature rise. This diode has a well-ordered forward conduction curve and low dynamic impedance.

In addition, another diode prevents the nickel-cadmium cell from going into deep reverse charge (reverse polarity). Figure 2 shows protection provided by this diode. When the cell power is exhausted, the reverse protection diode becomes conductive and diverts current away from the nickel-cadmium cell. This is a germanium diode with the lowest possible forward breakover voltage connected across the cell. Polarity is arranged so that the diode is biased off when the cell terminal voltage is normal. The diode conducts current around the cell when

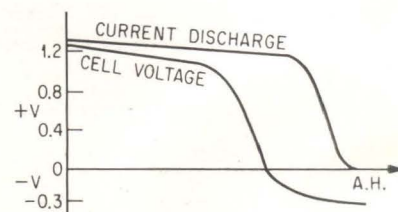

CURVE shows protection provided by reverse protective diode—Fig. 2



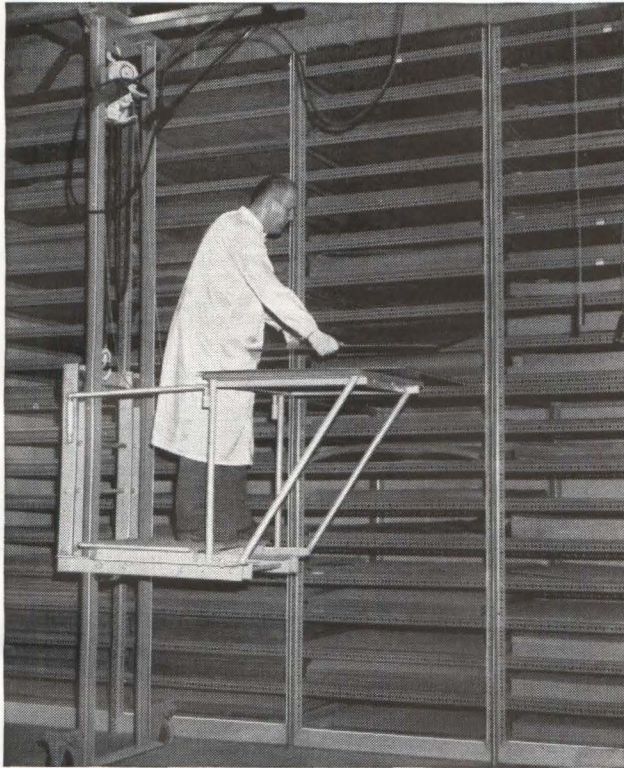

## 20,000 pounds of COPPER-CLAD Laminates NOW in STOCK

We have systematically increased our stock of Synthane copper-clad laminated plastics. We now have 20,000 lbs. of copper-clad sheets, made under clean room conditions, ready to ship or fabricate immediately.

Our stock includes both paper phenolic and glass epoxy grades in a wide variety of laminate and foil thicknesses.

Standard sheet sizes stocked are 36" x 36", 36" x 42" and 36" x 48". Panels cut to your size are available.

Write for complete information about Synthane metal-clad laminates, using the coupon below.

# SYNTHANE

CORPORATION **S** OAKS, PENNA.

GLendale 2-2211 (Area Code 215) TWX 215-666-0589

Synthane-Pacific, 518 W. Garfield Ave., Glendale 4, Calif. TWX 213-240-2104U

Synthane Corporation, 36 River Rd., Oaks, Pa.

Gentlemen:

Please send me information about Synthane metal-clad laminates.

Name \_\_\_\_\_

Address \_\_\_\_\_

City \_\_\_\_\_ Zone \_\_\_\_\_ State \_\_\_\_\_

CIRCLE 201 ON READER SERVICE CARD

electronics December 13, 1963

## 1/4% ACCURACY UNIVERSAL BRIDGE

\*HI-RESOLUTION  
5000 DIVS/RANGE

**\$590**



Readout  
System

Model  
1313

### MEASURES

INDUCTANCE ..... 1 $\mu$ H to 100H

CAPACITANCE ..... 1pF to 110 $\mu$ F

RESISTANCE ..... 0.01 $\Omega$  to 110M $\Omega$

DIRECT READOUT ..... NO FACTORS

BUILT-IN 1kc and 10kc OSCILLATORS

100 cps to 20kc WITH EXT. OSCILLATOR

\*Reads  
69.36 $\mu$ F

Write  
for detailed  
catalog sheet.

# MARCONI INSTRUMENTS

DIVISION OF ENGLISH ELECTRIC CORPORATION  
111 CEDAR LANE • ENGLEWOOD, NEW JERSEY

CIRCLE 51 ON READER SERVICE CARD 51



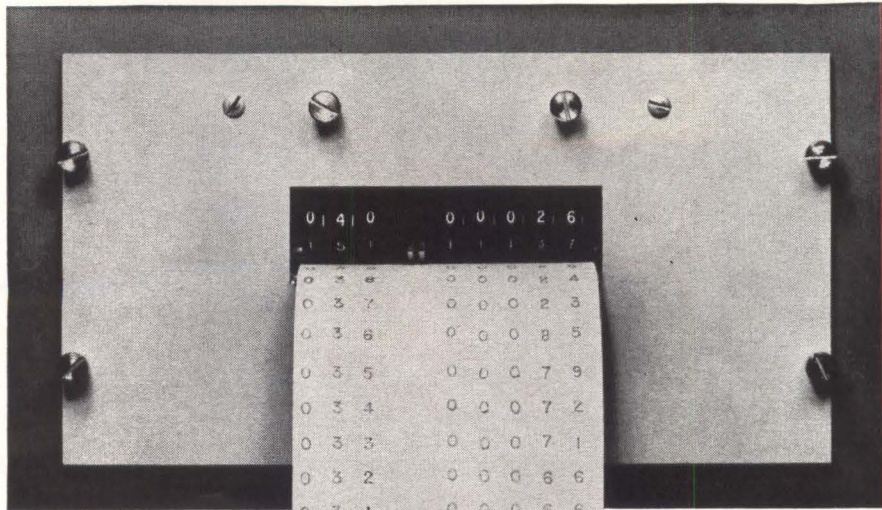

## A Count Printer for as little as \$258

Designed for custom use, the Texas Instruments Count Printer is a simple, low cost instrument capable of accumulating sequential input pulses at 600/minute. The accumulated total can be printed up to 60 times/minute on ordinary 3-inch adding machine tape . . . both dial total and last printed total are immediately vis-

ible. Compactly assembled on a 4 $\frac{3}{8}$ " by 7 $\frac{1}{8}$ " panel, the Count Printer is less than 7" deep and weighs only 3 $\frac{1}{2}$  pounds. It is available with either one or two in-line count channels for a-c or d-c operation. Each channel has independent count and reset functions. Prices start at \$258 list. Write for full information.

INDUSTRIAL  
PRODUCTS  
GROUP



**TEXAS INSTRUMENTS**  
INCORPORATED  
P. O. BOX 66027 HOUSTON, TEXAS 77006

SENSING • RECORDING • TESTING • DIGITIZING INSTRUMENTS  
THE INSTRUMENTS OF TEXAS INSTRUMENTS <sup>564</sup>

CIRCLE 52 ON READER SERVICE CARD

## NIMS

NATIONWIDE IMPROVED MAIL SERVICE PROGRAM

For Better Service  
Your Post Office  
Suggests

That You Mail Early In The Day!

the voltage of the cell goes to  $-0.3$  volts.

Sonotone is incorporating this system into a line of rechargeable cells to fit commercial needs where multicelled nickel-cadmium batteries are required such as: portable tv sets, drills, toothbrushes, and a host of consumer products calling for "cordless" power.

## Microwave Tubes Get Cheaper, Less Noisy

LONDON—Less expensive millimeter tubes, lower noise temperatures, and simpler design techniques for diode parametric amplifiers, highlighted the conference on Design and Use of Microwave tubes, held here October 16-18.

The assertion that millimetric sources should cost only slightly more than conventional centimetric tubes came from the Standard Telecommunications Laboratories in a paper by J. Froom and T. M. Jackson. By using novel machining techniques and high-precision gaging methods, they have developed an 8-mm reflex klystron with a life expectancy of over 10,000 hours.

One tube has already achieved 2,000 hours with no observable change in output.

Main component in this one-watt klystron is a copper block into which a precision ground hob is driven. This simultaneously forms both the cavity shape and the locating bore for the reflector. The cathode locating bore is formed while the block is still on the hob. The output transition and beam tunnel are inserted by spark machining and the cavity completed by pressure welding. The cavity frequency is monitored throughout the whole of the pressure welding operation. With this technique each tube has identical electron optical systems and differs only in cavity size and output couplings.

Output powers available vary from 2.7 watts at 13.6 mm down to 0.01 watt at 2.7. Mechanical tuning to provide a 5-percent tuning range on an 8-mm tube is obtained by attaching a tunable cavity outside the vacuum envelope.

An alternative but more expensive source under development is a backward-wave oscillator using a planar stub-supported meander line. The line is formed by spark ma-



chining a molybdenum film to produce 0.005-in.-wide bars and gaps. The whole circuit including the output transition is machined simultaneously. The tube uses a non-convergent gun and oscillates over the range 50-75 Gc.

**Less Noise** — In the search for lower and lower noise temperatures in microwave tubes, quadrupole amplifiers up to 1 Gc show a clear lead. Experimental models developed by the M-O Valve Company Ltd. operating between 400 and 1,000 Mc provide power gains of 20db over a 10-percent bandwidth about the center frequency with only a 1.5 db noise figure.

In the amplifier a uniform axial magnetic field is applied to pass a beam of electrons through three sets of r-f couplers to a collector. The field is adjusted so that the cyclotron frequency of the electrons is equal to the frequency to be amplified.

At the first coupler, the r-f field spirals the electrons into helical paths of increasing radii. The beam emerges cylindrically to pass through the quadrupole electrodes to the final coupler from which the output is obtained. The quadrupole electrodes produce a rotating electric field at the cyclotron frequency. When operating in the degenerate mode with the pump frequency twice the signal frequency a gain in kinetic energy occurs.

The amplifier will also operate in a non-degenerate mode where the pump and signal frequencies are unequal, adding three db to the noise factor. Typical experimental applications are in radio astronomy, and ground approach radars where a non-degenerate mode application gave a 5-db improvement over existing amplifiers.

A new, simple design procedure for diode parametric amplifiers developed by A. B. McNaughton and J. G. West of the General Electric Company of England uses modified Smith charts to derive design parameters. Normal Smith charts cannot be applied when reflection coefficients become greater than unity as happens when the load contains negative immittance. Using a mirror image of the normal chart overcomes this and allows a plot to be made of the negative immittance variations against frequency.

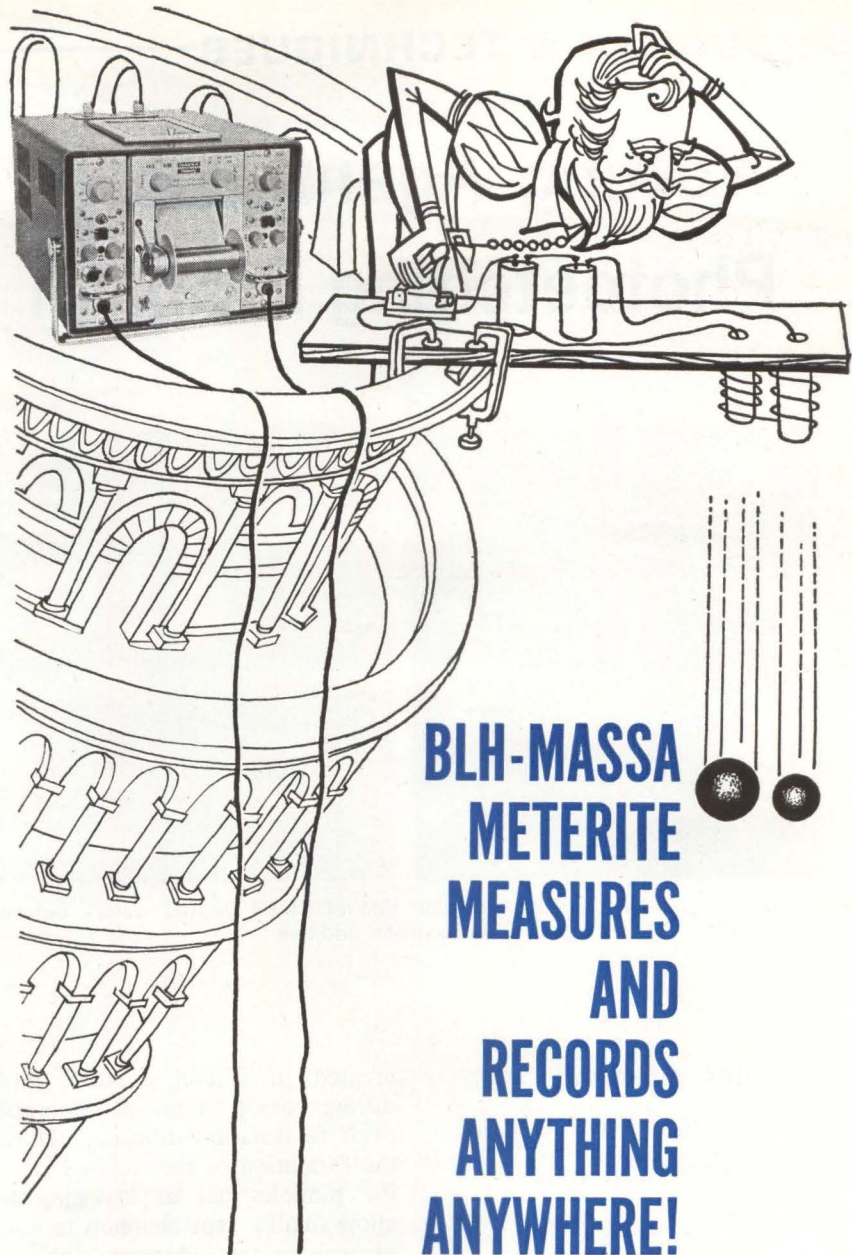

## BLH-MASSA METERITE MEASURES AND RECORDS ANYTHING ANYWHERE!

If Galileo had a Massa Meterite Strip Chart Recorder he would have had little difficulty timing the "free fall" of two different masses. The transducer signals, recorded in clear undistorted ink or electric traces on the two-channel rectangular co-ordinate chart, would be written proof of the common effect of gravity on falling bodies. The convenient two-channel Meterite can be hand carried and operated anywhere there is a signal to be recorded.

While you may not be proving a fundamental physical law, your own strip chart recording may be just as critical to you. Regardless of your signal source, there is a Massa plug-in preamplifier suited to the job. The Meterite uses any two of the six available Massa preamplifiers. Other Massa recording systems, with groups of four to twelve channels, are packaged in cabinet and standard rack mounting configurations.



**BALDWIN · LIMA ·  
HAMILTON**

Write for Meterite booklet  
"Pitfalls to Avoid  
when Purchasing  
Strip Chart Recorders"



ELECTRONICS DIVISION Waltham, Mass. 02154 Tel. (617) 894-6700  
Note: On Oct. 1, BLH Electronics Division acquired the Massa line of high speed strip chart recorders and oscillographs from Cohu Electronics, Inc.



# Wetting Agent Solves Photoetching Problem

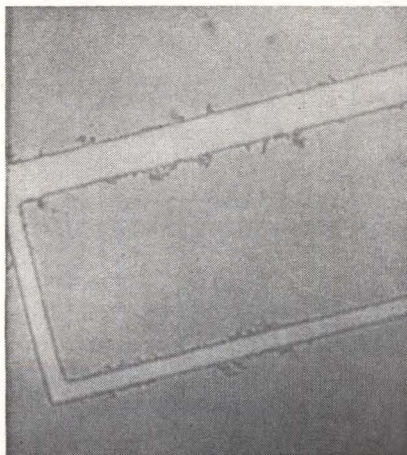

RESIST PATTERNS on silicon dioxide film of KMER treated wafers before (right) and after (left) use of fluorocarbon additive

Eliminates pinholing in oxide masking and reduces isolation loss

By I. F. Barditch  
C. Z. Leinkram  
Westinghouse Electric Corp.,  
Baltimore, Md.

**LACK OF ISOLATION** between individual components is an important cause of low yields in the production of single functional electronic blocks. This loss is mainly due to pinholing during the photoengraving operation. The addition of a surfactant in certain proportions to Kodak Metal Etch Resist (KMER) improves its wetting action and its ability to completely resist the following etching operations so that more complete isolation is provided to components.

**Problem**—A major cause of loss of isolation is the creation of pinholes, described as minute oxide-free areas

created in silicon dioxide masks during oxide removal operation prior to isolation diffusion. During the formation of the isolated region the pinholes act as leakages and allow small *p*-type channels to reach through to the substrate. Diffusing the resistor pattern over these pinholes enables direct contact from the resistor to the substrate. Under these conditions only the forward and reverse characteristics of the *p*-type substrate *n*-epitaxial region diode are observed.

Pinholes are due to uncoated areas in the photoresist during the formation of isolated regions. They are caused by either a non-wet area or occlusion of some foreign particle that drags across the wafer during spinning of the resist.

**Solution**—The solution to the problem is based on the inclusion of a fluorocarbon surfactant such as No. 1199 of Minnesota Mining and Manufacturing Company to increase the wicking action of the surface. With No. 1199, a low energy interface is formed to prevent levitation

## WESTON DISTRICT OFFICES & REPRESENTATIVES

- ALABAMA**—See Georgia  
**ARIZONA**—Runyon Co., 7140 E. Earl Dr., P.O. 1567, Scottsdale, 85252 (602) 946-8851  
**ARKANSAS**—See Texas  
**CALIFORNIA (Northern)**—Weston, 1125 Marshall St., Redwood City, 94063 (415) 369-4871  
**CALIFORNIA (Southern)**—Black & Strong, 3840 Crenshaw Blvd., Los Angeles, 90008 (213) 295-7751  
**COLORADO**—Parrish Electronics, 2130 So. Albion, Denver, 80222 (303) 756-9455  
**CONNECTICUT**—Weston, 221 Broad St., Milford (203) 776-6900  
**DELAWARE**—See Pennsylvania (Eastern)  
**DISTRICT OF COLUMBIA**—See Maryland  
**FLORIDA**—Weston, 1224 E. Colonial Dr., Orlando, 32803 (305) 423-6461  
**GEORGIA**—Weston, 3272 Peachtree Road, N.E. Atlanta, 30305 (404) 231-4431  
**IDAHO**—See Utah  
**ILLINOIS**—R. C. Whitmore & Assoc., 520 N. Michigan Ave., Chicago, 60611 (312) 664-1904  
**INDIANA**—See Illinois  
**IOWA**—See Illinois  
**KANSAS**—See Missouri  
**KENTUCKY**—See Ohio  
**LOUISIANA**—See Texas  
**MAINE**—See Massachusetts  
**MARYLAND**—QED Electronics, Inc., 10111 Colesville Rd., Silver Spring, 20901 (301) 588-8134  
**MASSACHUSETTS**—Weston, 591 North Ave., Wakefield, 01881 (617) 245-6600  
**MICHIGAN**—Weston, 17700 W. McNichols Rd., Detroit, 48235 (313) 532-5546  
**MINNESOTA**—R. G. Ragon, Inc., 1136 W. Larpenteur Ave., St. Paul 55113 (612) 488-6634  
**MISSISSIPPI**—See Texas  
**MISSOURI**—R. R. Burton Sales Co., 7546 Troast Ave., Room 20, Kansas City, 64131 (913) 523-7865, R. R. Burton Sales Co., 2050 Woodson Rd., Suite 201, St. Louis, (314) 426-2026  
**MONTANA**—See Colorado  
**NEBRASKA**—See Missouri  
**NEVADA**—See California (Northern)  
**NEW HAMPSHIRE**—See Massachusetts  
**NEW JERSEY (Northern)**—QED Electronics, Inc., 965 Nepperhan Ave., Yonkers, N. Y., 10703 (914) 968-2200  
**NEW JERSEY (Southern)**—QED Electronics, Inc., 2916 Federal St., Camden, 08105 (215) 925-8711  
**NEW MEXICO**—E. G. Miller, Jr., Co., 1900 Washington NE, Albuquerque, 87110 (505) 256-1585  
**NEW YORK (Metropolitan)**—QED Electronics, Inc., 965 Nepperhan Ave., Yonkers, 10703 (914) 968-2200  
**NEW YORK (Upstate)**—Reagan Electronics, Inc., 419 Central Ave., Albany, (518) 436-9649  
**NORTH CAROLINA**—Systems Service, 3748 Monroe Rd., Charlotte, (704) 377-3407  
**NORTH DAKOTA**—See Minnesota  
**OHIO**—Weston, 3951 Lee Road, Cleveland, (216) 752-3030, Weston, 3300 S. Dixie Drive, Dayton,, 45439 (513) 298-7511  
**OKLAHOMA**—See Texas  
**OREGON**—See Washington  
**PENNSYLVANIA (Eastern)**—QED Electronics, Inc., 2916 Federal St., Camden, N.J. 08105 (215) 925-8711  
**PENNSYLVANIA (Western)**—Weston, 875 Greentree Rd., Pittsburgh, (412) 922-4545  
**RHODE ISLAND**—See Massachusetts  
**SOUTH CAROLINA**—See North Carolina  
**SOUTH DAKOTA**—See Minnesota  
**TENNESSEE**—See Georgia  
**TEXAS**—Vista Engineering, 5531 Dyer St., Room 209, Dallas, 75206 (214) 363-6216  
**UTAH**—Parrish Electronics, 12 E. Stratford Ave., Salt Lake City, 84155 (801) 487-7847  
**VERMONT**—See Massachusetts  
**VIRGINIA**—See Maryland  
**WASHINGTON**—William R. Lamphear Co., Inc., 159 Western Ave., W. Seattle 98119 (206) 284-8150  
**WEST VIRGINIA (Western)**—See Pennsylvania  
**WISCONSIN (North)**—See Minnesota  
**WISCONSIN (South)**—See Illinois  
**WYOMING**—See Colorado  
**CANADA**—Daystrom Ltd., 1480 Dundas Highway East, Cooksville, Ontario, (416) 277-3191—5430 Ferrier St., Montreal, Quebec (514) 731-3476

CIRCLE 54 ON READER SERVICE CARD

December 13, 1963 electronics





Got a big  
job to do in  
small space?

...these  $\frac{3}{8}$ " Squaretrim<sup>®</sup> potentiometers  
are designed for large-scale performance  
in compact circuits

■ **Thinnest in the industry**—0.140 in. ■ **Lowest standard resistance value**—10 ohms ■ **Wire-in-groove for locked-in linearity** ■ **All standard configurations** When the job is big and the 'office' is small, the Daystrom  $\frac{3}{8}$ " Squaretrim subminiature potentiometers are the powerful choice. They weigh less than 1 gram, yet are rated one full watt *in still air* at 50° C, and permit much greater circuit density. Each series offers resistance values from 10Ω to 50 K, with tolerances of ± 5%. All are available with or without stops and can be humidity proofed. Operating range of Series 200 (6 in. Teflon leads), 201 (back pins) and 215 (side pins) is -55° C to +150° C. Corresponding Series 210, 218 and 255 are hi-temp. units, -55° C to +175° C.

The square trimming potentiometer was developed by Daystrom. Our unique wire-in-groove method of winding

the resistance element makes certain that each turn of the wire remains permanently separate from adjoining turns, thus assuring precise pick-off values...even under severest shock and vibration conditions. Other *standard* characteristics of the Squaretrim pot include: Longer winding for higher resolution, antibacklash worm gear construction; aluminum housing for greatest heat dissipation. These and other specifications are application-proved in the field. The  $\frac{3}{8}$ " Squaretrim pots are only a small part of a large family of Daystrom pots. Call your Weston salesman. He'll tell you about the whole family and supply samples for evaluation.

DAYSTROM POTENTIOMETERS ARE ANOTHER PRODUCT OF  
 **WESTON**  
INSTRUMENTS & ELECTRONICS  
614 Frelinghuysen Ave  
Newark 14, New Jersey  
Division of  
Daystrom, Incorporated



## PERFECTIONIST with an angle

When mode selection and setting of mirror angles is important, the perfectionist can depend on the LSI CW Gas Laser. This precision laboratory tool, designed by perfectionists for perfectionists, is equipped with both fine and coarse controls for setting and resetting mirror angles . . . accurate within 0.06 second of arc.

The GS-1 Continuous-Wave Gas Laser, a product of the LSI Laser Systems Center, is engineered and built to meet the most demanding specifications for broad-range CW laser experimentation. You can have it as a complete gas laser laboratory including thermopile, r-f wattmeter, image converter, a variety of plane and confocal mirrors, and a vacuum system . . . or you can start with the basic laser unit and add the accessories when you need them. Write or call for the GS-1 CW Gas Laser Bulletin.

*Note: If the GS-1 Laser does not fill all your requirements, Laser Systems Center's skilled technical staff will give you complete assistance in development of a CW laser specifically oriented to your needs.*

**LSI GS-1 CW Laser**  
Micrometer controls. Wavelength outputs of 6328 angstroms, 1.15 microns, 3.39 microns. Stable optical bench.

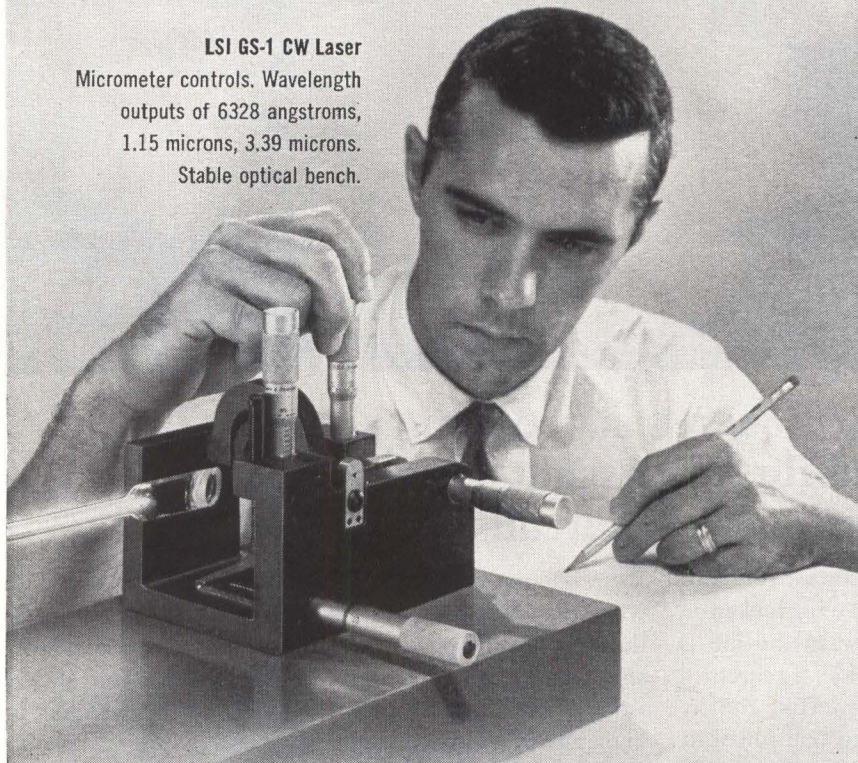

LEAR SIEGLER, INC.



**LASER SYSTEMS CENTER**  
FORMERLY TRION INSTRUMENTS, INC.

2320 WASHTEAW AVENUE  
ANN ARBOR, MICHIGAN  
TELEPHONE 313-665-8844

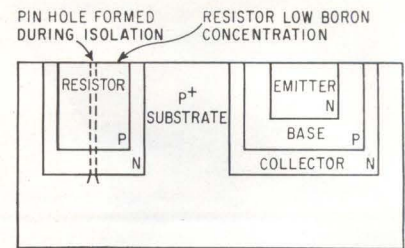

**LOSS OF ISOLATION** due to pinholing provides leakage path between resistor and collector. Poor wetting action during isolation diffusion is the main reason but a surfactant added to KMER solves the problem

of the resist film by the etchant. In essence, better coupling between resist and silicon oxide is achieved by formation of adsorption bonds between the silicon-dioxide surface and the photoresist polymer. Also, better flow of the resist occurs because the wetting action by the surfactant traps in place any small foreign particles that may have been occluded.

Two side effects are provided by addition of the surfactant. Resist removal is facilitated because the intersurface bond is more susceptible to attack by the cleaning agents, and resolution or acuteness of the patterns are noticeably improved.

The additive No. 1199 is useful only in the range of about 0.1 percent of the KMER. The addition of too much is as bad as too little.

Determination of an ideal concentration of surfactant to KMER is made by experiment. Various concentrations are applied to nearly perfect oxide-coated wafers at constant spinning speeds. Exposed in a 200 watt arc light beam for 2 minutes and then developed, the wafers are baked at 130 C for one hour. They are then covered with a buffered fluoride oxide etch for 20 minutes. After this etching step the wafers are stripped and observed in a metallurgical microscope.

The density of etch pits on the wafers indicate the lack of effectiveness of the photo resist material. Mixtures producing minimum densities are selected. Pit counts of sample wafers taken at random indicate a maximum of 3 or 4-fold improvement with a concentration of 0.1-percent additive to a given batch of KMER. This ideal concentration varies with the viscosity and polymerization of the KMER as supplied.



# DUROTHERM\* Non-freezing Soldering Tips

PATENT PENDING



**POSITIVELY CANNOT FREEZE OR STICK IN ANY IRON BECAUSE OF PROTECTIVE ANTI-CORROSIVE ALLOY!**

**AT LAST! MAXIMUM LIFE AND PERFORMANCE FROM BOTH ENDS OF COATED SOLDERING TIPS!**

**\*Inserted Section**— Inserted portion of tip protected by long-wearing 100% scale-resistant DURTHERM coating, bonded to base copper so securely that they become one integral part, to insure maximum heat transfer. Because there are no air spaces or looseness between coating and base copper, tip cannot become dented or out of round, or move or slide out of place. This means faster and more constant delivery of heat with no tip maintenance.

A—Heavy Iron Coating  
C—Pretinned Section  
D—Multi-coated and immunized

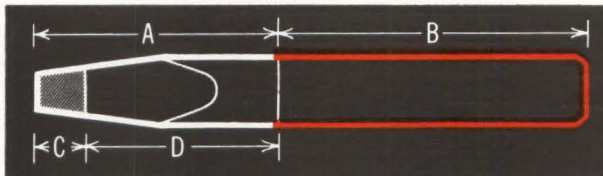

B—Scale-Resistant  
**DURTHERM COATING**  
Bonded to base copper

**\*Exposed Section**— Factory pretinning by exclusive process insures best performance and minimum maintenance. Exposed section is also multi-coated for extra long wear. This multi-coating immunizes shank of tip from solder, thus preventing solder from creeping into tip hole and spilling on components.

**\*Resulting In**— The longest wearing and best performing tip ever produced!

**\*Both Features Exclusive Hexacon Developments**

**HEXACON ELECTRIC COMPANY, 130 West Clay Ave., Roselle Park, N. J.**

SERVING INDUSTRY FOR MORE THAN THIRTY YEARS—PIONEER DESIGNER OF INDUSTRIAL SOLDERING IRONS AND COATED TIPS

CIRCLE 202 ON READER SERVICE CARD

**Eisler**

**A NAME TO REMEMBER IN MACHINERY FOR ELECTRONICS**

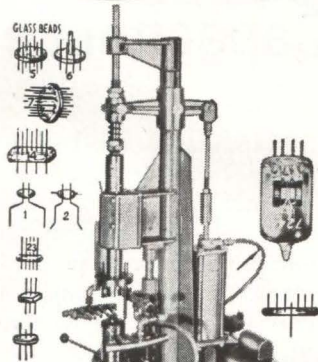

At left: No. 105-BST1 single position Button Stem and Wafer making machine—Fully automatic. Designed for small production runs or for laboratory use. Produces button stems up to 1 1/4" diameter. Machine can be supplied with up to 24 positions.

Illustrated below: An Eisler precision Vertical Spot Welder designed exclusively for welding of electronic components. Available in sizes from 1/2 to 7 1/2 KVA.



Write us today for full particulars!

**EISLER ENGINEERING CO., INC.**

Charles Eisler Jr., President

751 So. 13th St., Newark 3, N. J.

CIRCLE 203 ON READER SERVICE CARD

electronics December 13, 1963

**NEW RF BRIDGE MEASURES H.F. IMPEDANCES WHILE OPERATING AT POWERS UP TO 1000 WATTS**

Model OIB-2

\$695.00



Operating Impedance Bridge

- Frequency Range 2—30 Mc.
- Built-in null detector for measuring antennas and other loads under power.
- Simple to use—tune R & X dials for null—no initial balance required.
- Measure antenna impedance and VSWR while transmitters and antennas are operating.
- Measure actual operating impedance of individual elements in complex arrays—very low insertion effect.
- Can also be used with generator and external detector as normal RF Bridge.

**DELTA ELECTRONICS**

DELTA ELECTRONICS, INC. 4206 WHEELER AVENUE  
ALEXANDRIA, VIRGINIA



CIRCLE 57 ON READER SERVICE CARD

57



# Tape Punch Has Electronic Keyboard

Mechanical linkages replaced by solid-state logic

**SERIES 1010** Tapewriter electronically encodes magnetic key closures of up to 48 alphanumeric and symbols, punches the appropriate code holes on paper or Mylar tape and

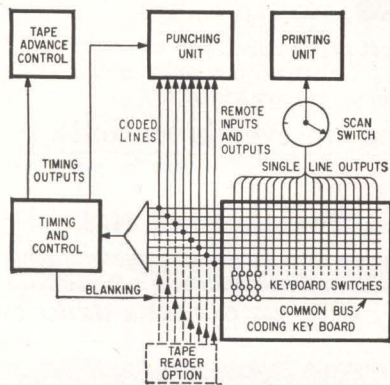

simultaneously prints the character at the bottom edge of the tape for immediate visual verification.

Although it must perform mechanically oriented functions, the device accomplishes these with solid-state electronic elements and a minimum of mechanical parts, as more than 75 percent of the system consists of electronic components. Series 1010 Tapewriter encodes key closures into tape-hole codes, provides timing from key closures for system control, generates electronic blanking to prevent keyboard jamming, controls tape advance and punches encoded characters onto the tape.

The all-electronic keyboard consists of a single gold-plated, etched-circuit board for the mounting of precious-metal wiping contacts that are activated by magnetic keys and a programmable diode matrix that encodes key closures into codes required by the punch and memory



elements for the printing system. Code modification or the insertion of new codes requires only the rearrangement of the matrix or replacement of the p-c board with standard code variations.

Linking the unit with any logic system requires no elaborate interface isolation buffering or filtering. Navigation Computer Corp., Valley Forge Industrial Park, Norristown, Pa.

CIRCLE 301, READER SERVICE CARD

## Field Effect Transistors Show Low Capacitance

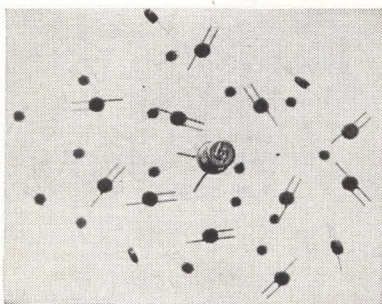

**TWO** field effect transistors, models 2N3112 and 2N3113, provide 50 picoamp maximum gate current and extremely low capacitance. The 2N3113 is packaged in a micro-miniature alumina/glass sandwich only 100 mils in diameter and 35 mils thick. The 2N3112 is packaged in the standard TO-18 configuration.

When the low-capacitance 2N-

3113 is used,  $C_{is}$  is less than 2.0 pf. This value rises to 3.5 pf for the 2N3112. Both Unifets have a pinch-off voltage range from 1.0 to 4.0 volts with transconductance limits between 50  $\mu$ mhos and 115  $\mu$ mhos. Low input current and capacitance make these voltage-controlled devices ideal for high input impedance a-c or d-c amplifiers, storage circuits, choppers and electrometers. Siliconix, Inc., 1140 West Evelyn Ave., Sunnyvale, Calif. (302)

### A-D Converters Achieve High Bit Rate

**FAMILY** of analog to digital and digital to analog converters operate at conversion rates to  $10^6$  bits per second. Designated models 1042

through 1046, these solid-state units accommodate word lengths from 4 to 8 bits including parity, employ a sampling aperture of only 300 nsec and require input power as low as 1 watt. Other features include unrestricted format flexibility and both serial and parallel output for A-to-D conversions.

Present future applications are expected to include high-speed telemetry, high-speed data acquisition and processing and digitized voice communications. Units weigh less





Opportunities for

## Design & Development Engineers in Electronic Signal Processing

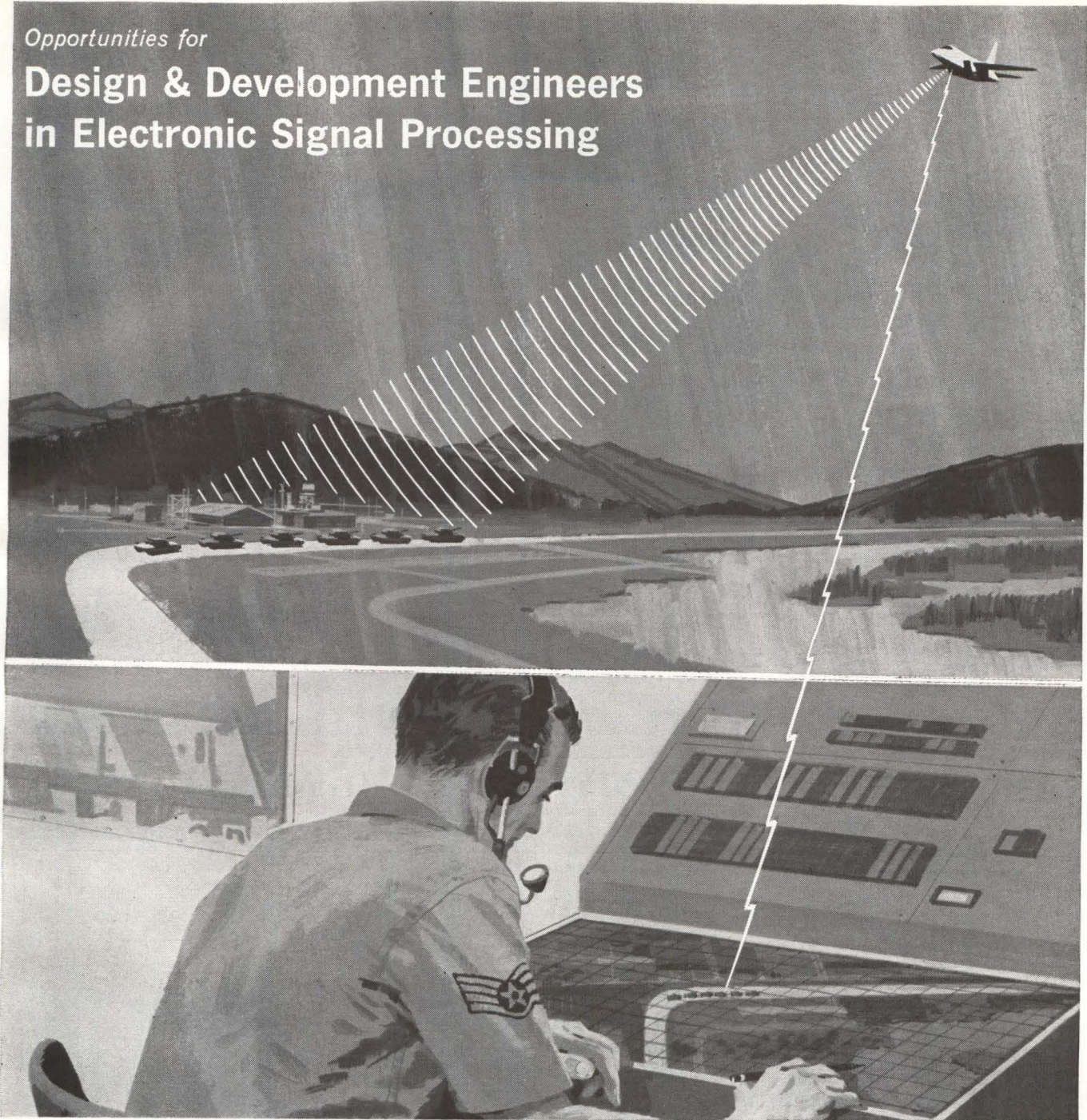

Design and development activities in the field of Electronic Signal Processing are rapidly expanding today at HUGHES Aerospace Divisions.

Development of systems utilizing advanced correlation and matched filter techniques for *High-Resolution Radar*, *Acoustic Detection & Classification* and *Pulse Doppler Radar* is being accelerated.

Specialists in Signal Processing, Circuit Design, Mechanical Design, Packaging Design, Performance Analysis and Project Engineering will be interested in the outstanding assignments now available.

Graduate engineers with experience in wide-band video amplifiers; high-resolution cathode ray tube circuits and applications (including ultra-linear sweep, gamma correction and dynamic focus); high-voltage power supplies; low-jitter timing circuitry; high-speed analog sampling circuitry; precision film transports; ultra-high speed film development; scan conversion systems; synthetic array radar systems; imagery recording, or similar fields—are invited to submit resumes.

For immediate consideration  
please write:

**Mr. Robert A. Martin**  
Head of Employment  
HUGHES Aerospace Divisions  
11940 W. Jefferson Blvd.  
Culver City 59, Calif.

*Creating a new world with electronics*

**HUGHES**

HUGHES AIRCRAFT COMPANY  
AEROSPACE DIVISIONS

An equal opportunity employer

U. S. CITIZENSHIP REQUIRED



## BUSS quick-acting fuses

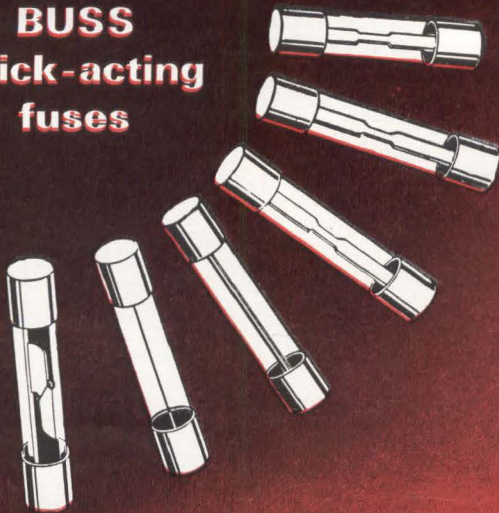

"Fast Acting" fuses for protection of sensitive instruments or delicate apparatus;—or normal acting fuses for protection where circuit is not subject to starting currents or surges.

# BUSS

Write for BUSS  
Bulletin SFB.

BUSSMANN MFG. DIVISION, McGraw-Edison Co., St. Louis 7, Mo.

## FUSETRON dual-element fuses time-delay type

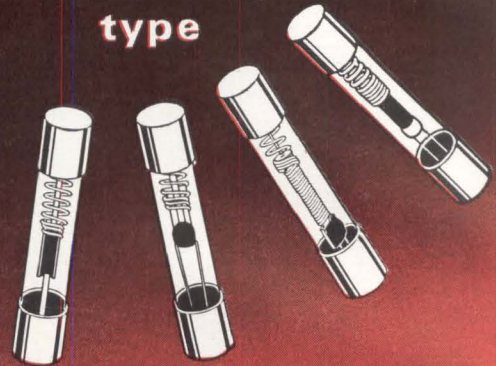

"Slow blowing" fuses for circuits where harmless surges occur. These fuses prevent needless outages by safely holding starting currents or surges,—yet they provide safe, positive protection against short-circuits or continued overloads.

# BUSS

Write for BUSS  
Bulletin SFB.

BUSSMANN MFG. DIVISION, McGraw-Edison Co., St. Louis 7, Mo.

## BUSS : the complete line of fuses

CIRCLE 61 ON READER SERVICE CARD

CIRCLE 61 ON READER SERVICE CARD

than three pounds and require minimal d-c power. Operation is based upon the logical approximation method that entails the buildup of a comparison voltage in the A-to-D converters, or an analog voltage as the output of the D-to-A converters. Vector Manufacturing Company, Southampton, Pa.

CIRCLE 303, READER SERVICE CARD

### Modular Enclosures Offer RFI Shielding

Two Emcor rfi-shielded modular enclosure systems are available. The Emcor Special series is designed to meet both the electrical and mechanical rfi shielding requirements of NASA. It is designed primarily for use in aerospace and missile control. The Emcor III system is designed for broader application along

industrial lines. It meets the electrical requirement standards of NASA. Test results show that the Emcor Special series maintained adequate attenuation over a frequency range of 0.15 to 1,000 Mc. The Emcor III series also surpassed minimum attenuation requirements over the same megacycle scale. With the Emcor Special series, a choice of vertical rack, sloped front and low silhouette enclosure frame shapes in 19 and 24-in. panel widths are available. Ingersoll Products, Div. of Borg-Warner Corp., 1000 W 120th St., Chicago 43, Ill. (304)

### High-Q Quartz Cavities Are Frequency Variable

EXPERIMENTS with liquid, solid, gaseous and plasma samples may be performed with these new X, K and

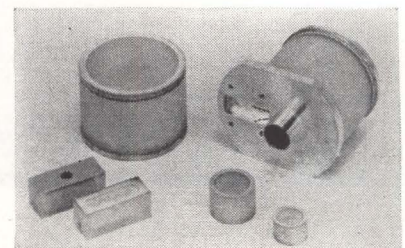

R-band quartz cavities. Approaching theoretical Q, cavities have a thin, integrally-bonded layer of silver and are frequency variable. They will operate at 9.5 Gc, 24.5 Gc and 35.5 Gc, at room or liquid helium temperature. Electromagnetic resonance cavities have variable coupling and are compatible with existing commercial EMR equipment. Cavities are priced from \$150 to \$500. Strand Labs, Inc., 143 Main St., Cambridge, Mass. (305)



3" dia. x 3¼" long, 16 ounces

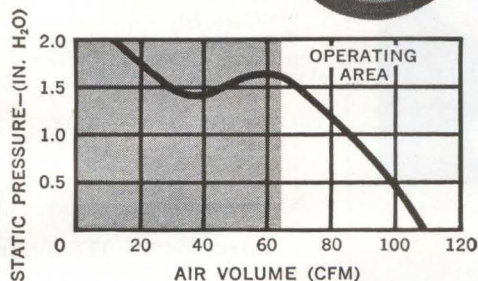

NEW VANEAXIAL

AC/DC

# UNIVERSAL BLOWER

Globe's VAX-3-GN Universal Blower gives you 110 cfm. free air, with a design point of 68 cfm. at 1.5" H<sub>2</sub>O—on either 115 v.d.c. or 115 v.a.c., 60 cycle power. Other voltages can be supplied. Nominal speed is 14,000 rpm.

You can standardize on this extremely versatile blower for ground support and commercial electronic cooling. It's designed to meet MIL specs, having passed shock and vibration per MIL-E-5272. Production tooling makes this blower economical. Prototypes can be in your hands tomorrow (telephone BA-2-3741 for part no. 19A908); production orders normally delivered in a short time.

Rugged mechanical protection is provided by the black anodized aluminum housing and propeller. Mount by clamping to servo ring at either end. Nominal life exceeds 1000 hours. Max. current is 0.47 amps at free air delivery. Request Bulletin GNB from Globe Industries, Inc., 1784 Stanley Avenue, Dayton 4, Ohio.

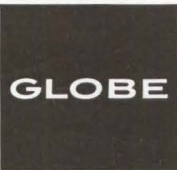

**GLOBE INDUSTRIES, INC.**



CIRCLE 204 ON READER SERVICE CARD

..... of unquestioned high quality

## BUSS FUSEHOLDERS

- LAMP INDICATING SERIES HK AND HJ FOR ¼ x 1 and ¼ x ¼ INCH FUSES

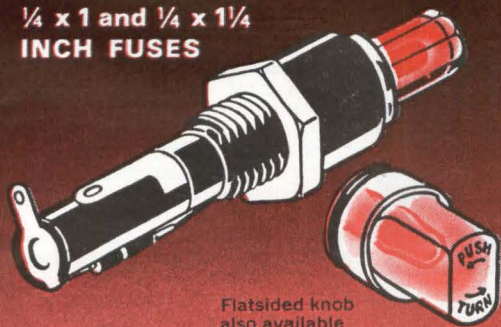

Flatsided knob also available

Provides quick, positive visual identification of faulted circuit. Transparent knob permits indicating light to be readily seen.

Bayonet type knob-molded body—strong, coil spring provides positive contact on ends of fuse.

Fuseholder designed to withstand vibration such as occurs in aircraft applications. Terminals held mechanically as well as by solder.

Holder can be used in panels up to 3/16 inches thick.

# BUSS

Write for BUSS Bulletin SFB.

BUSSMANN MFG. DIVISION, McGraw-Edison Co., St. Louis 7, Mo.

CIRCLE 61 ON READER SERVICE CARD



If you should have a special problem in electrical protection...

... we welcome your request either to quote or to help in selecting the type of fuse or fuse mounting best suited to your particular conditions.

Submit description or sketch, showing type of fuse to be used, number of circuits, type of terminal, etc. If your protection problem is still in the engineering state, tell us current, voltage, load characteristics, etc. Be sure to get the latest information BEFORE final design is crystallized.

At any time our staff of fuse engineers is at your service to help solve your problems in electrical protection and save you engineering time.

# BUSS

Just call or write:

BUSSMANN MFG. DIVISION, McGraw-Edison Co., St. Louis 7, Mo.

CIRCLE 61 ON READER SERVICE CARD



**CHRISTIE**

SINCE 1929®

# D-C POWER HORSE

## REGULATED "K" SERIES HI-CURRENT SUPPLIES

5½ to 135 volt d-c  
50 to 1500 amp  
0.25% Regulation

Ultra-Reliable  
High Overload Capacity  
Economical

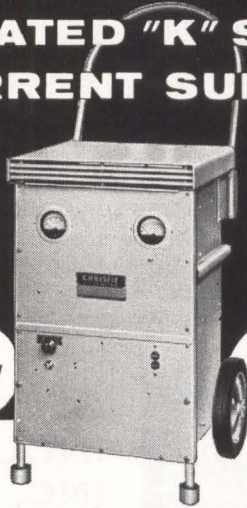

Silicon Rectifiers  
Military & RFI Specs  
55°C Ambient

100, 200 & 300 amp  
In Various Cabinet  
Styles from Stock

Also 200 other Models of Power Supplies & Battery Chargers • Write for Catalog  
**CHRISTIE ELECTRIC CORP.** 3400 West 67th Street, Los Angeles 43, Calif.

CIRCLE 205 ON READER SERVICE CARD

CEI Type  
970A & 770A  
RECEIVERS

for AM, FM, CW and  
**PULSE  
RECEPTION**



An outstanding feature of these receivers is the pulse AGC circuitry which has a charge time sufficiently short to permit pulse widths as narrow as permitted by the bandwidth selected and as wide as a square wave. Discharge time is sufficiently long to permit normal operation with pulse repetition rates as low as 50 pps. The loop gain of the AGC circuitry will hold the output pulse amplitude within narrow limits with large RF input level changes. The pulse handling capability and selectable IF bandwidths make these very versatile instruments.

**970A FREQUENCY RANGE**

30-300mc in two bands  
Band A: 30-90mc  
Band B: 60-300mc

**770A FREQUENCY RANGE**

235-1000 in 2 bands  
Band A: 235-500mc  
Band B: 490-1000mc

**Communication Electronics Incorporated**

4908 HAMPDEN LANE, BETHESDA 14, MARYLAND

62 CIRCLE 62 ON READER SERVICE CARD

## LITERATURE OF THE WEEK

**LABORATORY OVENS** Despatch Oven Co., 619 S.E. 8th St., Minneapolis, Minn. Bulletin describes V type laboratory and production ovens with Sensi-tronic In-po-trol control.

CIRCLE 360, READER SERVICE CARD

**ELECTRIC WAVE FILTERS** Pulse Control, a division of Jamieson Industries, Inc., 7900 Haskell Ave., Van Nuys, Calif. Bulletin PC-303 features a line of custom-built electric wave filters. (361)

**MAGNETIC LAMINATIONS** Howcor Laminations, a division of Howard Industries, Inc., 3912 West McLean Ave., Chicago, Ill. 60647, has published an illustrated folder describing its experience and facilities for serving users of magnetic laminations. (362)

**PERFORATED TAPE READER** Data-stor Division of Cook Electric Co., Skokie, Ill., offers a brochure containing features and specifications for the model 55 perforated tape reader. (363)

**MICROELECTRONICS** ITT Federal Laboratories, 500 Washington Ave., Nutley, N. J., has published a brochure describing its microelectronics capabilities. (364)

**ULTRASONIC CLEANING EQUIPMENT** Crest Ultrasonics Corp., Scotch Road, Mercer County Airport, Trenton, N. J., offers a quick-reference purchasing and engineering guide to its ultrasonic cleaning equipment. (365)

**L-F/VLF RECEIVER** Interstate Electronics Corp., 707 E. Vermont Ave., Anaheim, Calif. A 4-page technical brochure gives full information on the model LF-610 low-frequency timing receiver for WWVB signals. (366)

**SATELLITE TAPE RECORDERS** Leach Corp., 1123 Wilshire Blvd., Los Angeles 17, Calif. Bulletin STR-2000 deals with a line of miniature, hermetically-sealed satellite tape recorders. (367)

**PORTABLE OSCILLOSCOPE** Fairchild Camera and Instrument Corp., DuMont Laboratories, 750 Bloomfield Ave., Clifton, N. J. A mailing piece illustrates and describes the 765 MH Portoscope, a 13-kv crt. (368)

**ELECTRONIC PROGRAMMER TIMERS** B. F. Goodrich Aerospace and Defense Products, Akron, O. Bulletin 3-5926 illustrates and describes electronic programmer timers for use in missile, aircraft and ground installations. (369)

**SHIFT REGISTER APPLICATIONS** C. P. Clare & Co., 3101 Pratt Blvd., Chicago, Ill., 60645. New developments in shift register applications, using the Clared flip-flop control modules as the basic component are described in "Supplement to Manual 401." (370)

**ELECTRONIC CERAMICS** Diamonite Products Mfg. Co., Shreve, Ohio, announces a 16-page brochure presenting data on its specialized line of high-alumina electronic ceramics. (371)

December 13, 1963 electronics



**JUST PUBLISHED!**

**IMPACT  
OF  
MICROELECTRONICS**

Edited by George T. Jacobi,  
IIT Research Institute  
and Samuel Weber, electronics



The Proceedings of the Conference on the Impact of Microelectronics, co-sponsored by the Armour Research Foundation (now IIT Research Institute) and electronics, a McGraw-Hill Publication, has just been published by electronics. The Conference, held last June 26-27 at the Illinois Institute of Technology, was acclaimed by the attendees and the industry at large. Now, in book form, all the invited papers and talks presented at the conference are available to you.

To whet your appetite, here are some of the contents:

**The Electronics Components Industry and Microelectronics**  
by Robert C. Sprague, Chairman of the Board, Sprague Electric Company.

**Profit and Loss in Microelectronics**  
by Robert W. Galvin, President, Motorola Inc.

**Government Needs and Policies in the Age of Microelectronics**  
by James M. Bridges, Director of Communications and Electronics, Department of Defense.

**Management of Research and Engineering for Microelectronics Systems**  
by Dr. Peter B. Myers and Arthur P. Stern, Electronic Systems and Products Division, Martin Company.

**In House or Not: The Changing Buyer—Vendor Interface**  
by F. J. Van Poppelen, Jr., Vice President-Marketing, Signetics Corporation.

**Current Technical Status and Problems in Microelectronics**  
by Jack S. Kilby, Integrated Circuits Dept., Texas Instruments, Inc.

**Ultimate Limits of Microelectronics**  
by Dr. J. T. Wallmark, RCA Laboratories, David Sarnoff Research Center

**Reliability in Microelectronics**  
by Ernest R. Jervis, ARINC Research Corporation.

**Engineering Education in an Era of Changing Technology**  
by Dr. John Bardeen, University of Illinois.

**IMPACT OF MICROELECTRONICS** is must reading for men with a marketing and technical interest in this dynamic field of activity. Crammed with useful information, this neatly designed, 120 page volume keeps you up-to-date on this fast moving technology. Order today. Only \$3.50 per copy.

**ORDER FORM**

electronics Reprint Department  
McGraw-Hill Publishing Co., Inc.  
330 West 42nd Street  
New York, N.Y. 10036

Dear Sirs:

Send me \_\_\_\_\_ copies of **IMPACT OF MICROELECTRONICS**  
(\$3.50 per copy)

I am enclosing \_\_\_\_\_ (cash or check)

Bill me later \_\_\_\_\_ Bill my company \_\_\_\_\_

MY NAME \_\_\_\_\_ POSITION \_\_\_\_\_

COMPANY \_\_\_\_\_

ADDRESS \_\_\_\_\_

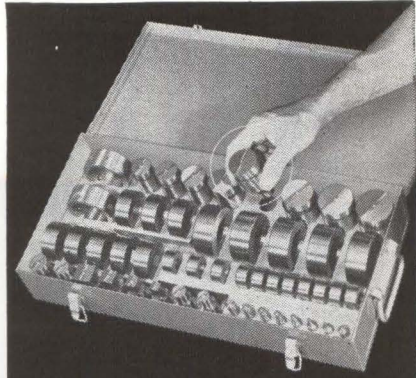

the right punch & die  
at your finger tips...  
**NEW DI-ACRO  
PUNCH PAKS**

**Punch Pak No. 1 - \$139.50**  
**Punch Pak No. 2 - \$259.50**

- Off the shelf delivery
- Adapters to fit any punch press

Di-Acro Punch-Paks save you money, cut production delays. No time lost looking for the right size or waiting for special orders. Cost is approximately 10 per cent less than individual punch and die sets—with the rugged, steel store-or-carry chest free. All Di-Acro Punches and Dies are precision made of quality tool steel.

**PUNCH-PAK NO. 1** contains 30 sizes of round punches and dies from 3/64" to 1/2" in increments of 1/64".

**PUNCH-PAK NO. 2** contains round punches and dies from 1/16" to 1/2" in 1/16" increments, round sizes from 1/2" to 2" in 1/8" increments, squares in 1/2", 5/8", 3/4" and 1" sizes, one die holder and two die adapters.

Die Adapter A-2 3/4" diameter—1 1/4" bore, Die Adapter B-2 3/4" diameter—2 1/8" bore.

**DIMENSION DATA**

All Di-Acro Punches to 1/2" have 1/2" diameter shanks, 2 13/32" length.  
All Di-Acro Punches from 1/2" to 2" have 1" diameter shanks, 3 1/8" length.  
All Di-Acro Dies to 3/4" are 1 1/4" diameter, 5/8" high.  
All Di-Acro Dies from 3/4" to 1 3/8" are 2 1/8" diameter, 7/8" high.  
All Di-Acro Dies from 1 1/2" to 2" are 2 3/4" diameter, 15/32" high.

**PUNCH AND DIE HOLDERS**

which adapt Di-Acro Punches and Dies to any punch press are listed in literature on single station punch and die program. Ask for it... also for literature on new Adjustable Punch and Die program.

For full information consult Yellow Pages of your phone book under Machinery-Machine Tools for the name of your Di-Acro distributor or write us.



Pronounced die-ack-ro  
**DI-ACRO CORPORATION**  
Formerly O'Neil Irwin Mfg. Co.

4312 Eighth Avenue  
Lake City, Minnesota • U.S.A.



WHY SETTLE FOR LESS?

**0.01%**  
**ACCURATE**

SIZE 23 RESOLVER

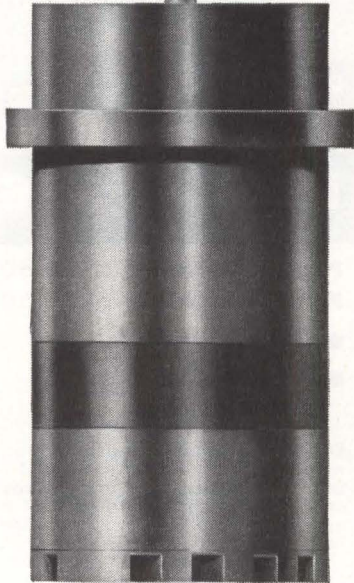

Type 23RV4al

**Here's a top rated resolver that's priced surprisingly low. So why settle for less than Ford Instrument's highly accurate Size 23 Resolver...the resolver that exceeds MIL-E-5272A.**

**SPECIFICATIONS:**

- Maximum Functional Error (over 360° of shaft rotation)...0.01% of input voltage at maximum coupling
  - Maximum Total Null Voltage... 1 mv/volt input maximum
  - Maximum Interaxis Error (rotor) ... 1.5 minutes
  - Maximum Interaxis Error (stator) ... 1.5 minutes
  - Maximum Variation of Transformation Ratio (with input voltage from 6-18 volts with 12 volts input as reference) ... 0.03%
  - Maximum Variation of Transformation Ratio (with input voltage from 0.3 to 6 volts) ... 0.02% of 6 volts
- 0.025% accuracy available in size 15  
Bulletin FR 62-1 gives full specifications. It's yours for the asking. Write:

**FORD INSTRUMENT CO.**

Division of Sperry Rand Corporation  
31-10 Thomson Ave., Long Island City 1, N. Y.

**PEOPLE AND PLANTS**

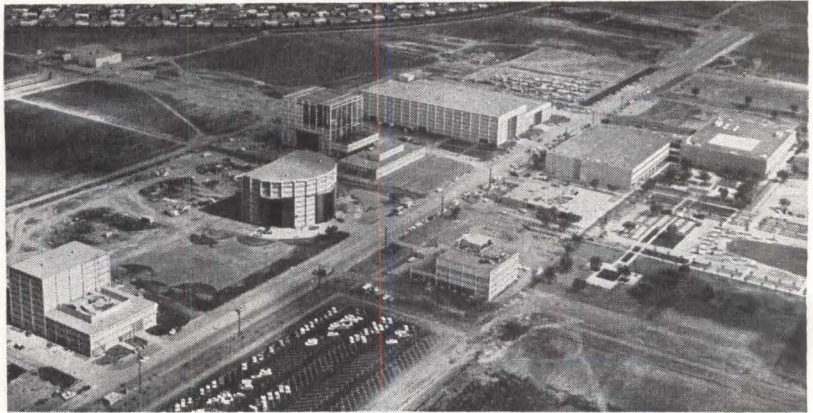

## Space Center Opens

**CULMINATING** a two-year effort to develop space research and development facilities, the \$25 million Douglas Aircraft Space Systems Center has been opened in Huntington Beach, Calif.

The center consists of nine buildings, totaling 700,000 sq ft, on a 245-acre site near the Pacific Ocean.

Included is a 3-story systems integration laboratory which duplicates control centers at the Atlantic Missile Range and the Douglas Sacramento static test facility, allowing engineers to evaluate complete ground support systems and their compatibility with the vehicle during a simulated count-down through use of vehicle components and computer-controlled vehicle simulators. This facility eliminates later testing of minor parts which would tie up an entire missile.

An engineering complex is made up of two 3-story buildings, one of which houses a circuit study laboratory containing test equipment and hand tools to enable engineers to design circuits for space applications, breadboard and then test them immediately at benches adjoining their desks.

A 5-story semicircular laboratory can accommodate five major space vehicle components at a time for evaluating launch support systems.

A space simulation laboratory simulates a 500-mile altitude for testing the reaction of life-size prototype space equipment and man as well as duplicating the sun in intensity and special content with a 4-ft-diameter beam of light.

Other buildings at the center are a production test laboratory, a tooling tower complex, a manufacturing and assembly building, a cafeteria and a central heating and power plant.

The 2,600 employees are currently working on the Saturn S-IVB, upper stage of the Saturn space vehicle. The Saturn was the primary reason for choosing the Huntington Beach site, according to Charles R. Able, Missiles and Space Systems vice-president/general manager. Because the S-IVB is 58 ft long and 2½ ft in diameter, it can only be transported by ocean barge.

### Basic Announces New Appointment

H. P. EELLS, JR., chairman and president of Basic Inc., Cleveland, O., announces the appointment of E. S. Willis as assistant to the president for electronics. In this capacity he

will be associated with Regulus Inc., in which company Basic holds the controlling position. Located in Mt. Gilead, O., Regulus is a designer and manufacturer of power supplies and related automatic control equipment for the computer and communications field.

Willis has been associated with



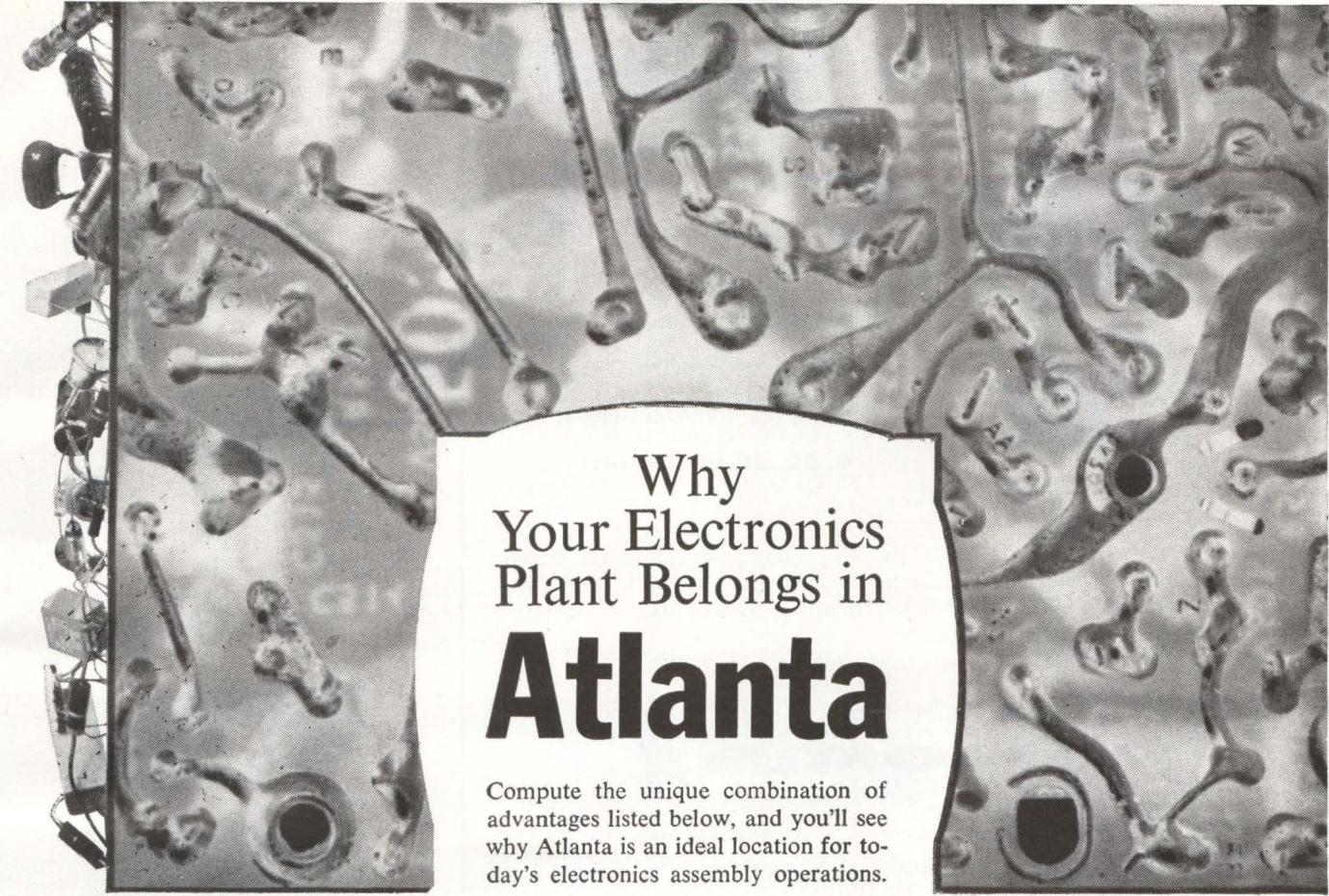

## Why Your Electronics Plant Belongs in **Atlanta**

Compute the unique combination of advantages listed below, and you'll see why Atlanta is an ideal location for today's electronics assembly operations.

**High productivity.** For every dollar of wages paid, an Atlanta manufacturer of electronic measuring instruments can expect \$3.76 in value added by manufacture. In Chicago he would gain only \$2.90; in New York-New Jersey, \$2.64 (U. S. Census figures). Atlanta's large labor pool also permits a high degree of selective hiring.

**Trained engineers and technicians.** In 1962 Atlanta's 19 colleges and universities granted over 1,000 Bachelor of Science degrees — more than 200 in electrical engineering and physics. Nearly 300 technicians graduate here yearly.

**Proximity to aerospace and atomic energy installations.** Atlanta is at the center of some 21 military, NASA, AEC, and airframe manufacturing installations, including Oak Ridge, Redstone Arsenal, Cape Canaveral.

**Transportation.** Close liaison between manufacturer and customer and rapid freight service are guaranteed by Atlanta's transportation facilities. Seven airlines offer non-stop service from Atlanta to more than 50 cities; 75 truck lines provide scheduled service to every major market in the nation; 7 railroads operate into and out of the city over 13 main lines.

**Independent research capabilities.** Georgia Tech's Engineering Experiment Station, Emory University, the University of Georgia, plus a number of private companies, offer a wide range of research capabilities on a contractual basis to business and industry.

Ask for an analysis of your company's probable success in Atlanta as prepared by Georgia Tech's 43-man Industrial Development Division. Check coupon; mail with your company letterhead. All inquiries confidential.

Please send me the following reports and other information as checked below.

1.  Calculators and Computers—A Manufacturing Opportunity in Atlanta
2.  Electronic Testing and Measuring Instruments—A Manufacturing Opportunity in Atlanta
3.  Electronics—A Manufacturing Opportunity in Georgia
4.  I would like information on the following aspect(s) of Atlanta's economic and general make-up (list) \_\_\_\_\_
5.  I want to know my company's prospects for success in Atlanta as analyzed by Georgia Tech's Industrial Development Division. We would be interested primarily in a new  plant  warehouse  sales office  other \_\_\_\_\_



"Forward Atlanta"  
Paul Miller, Industrial Manager  
Atlanta Chamber of Commerce  
1350 Commerce Building  
Atlanta 3, Ga. Phone: 521-0845

Name \_\_\_\_\_ Title \_\_\_\_\_

Company \_\_\_\_\_

Product \_\_\_\_\_

Street \_\_\_\_\_

City \_\_\_\_\_ Zone \_\_\_\_\_ State \_\_\_\_\_



# THERMOCOUPLE AMPLIFIER



MODEL 190

for

- RECORDER PREAMPLIFIERS
- OVEN CONTROLS
- GLASS FURNACES
- BEARING MONITORS
- METER PREAMPLIFIERS
- DC SHUNT AMPLIFIER

A new concept in solid-state DC amplifiers; no tubes, no transistors, no choppers. Typical gains 4000,  $\pm 5 \mu\text{v}$  null stability; ten-year life. Price only \$84.00; quantity discounts, immediate delivery.

Request Technical Bulletin No. 19

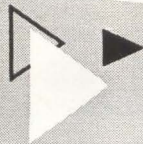

**acromag**<sup>®</sup>  
INCORPORATED

15360 TELEGRAPH RD.

DETROIT 39, MICH.

TELETYPE:  
313-  
538-4536

Phone: 538-4242, Area Code 313

CIRCLE 207 ON READER SERVICE CARD

# DYNAMICS

## VARIABLE ELECTRONIC FILTERS

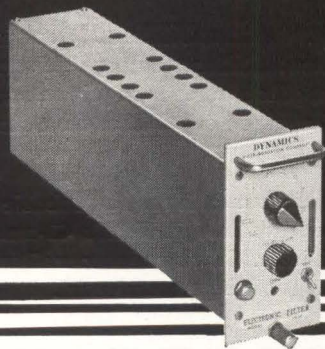

— 3rd to 6th order  
Tchebysheff  
Butterworth  
Linear Phase

- Up to 36 db/octave slope
- Low-pass or high-pass
- Low dc drift
- Source or load independent
- Drive long lines
- No insertion loss
- Variable frequency — 4-decade range

Noise and ripple: below 1 millivolt peak-to-peak, at the output  
Linearity: 0.1%  
Output voltage and current:  $\pm 10$  volts;  $\pm 100$  ma

Drift:  $\pm 2$  millivolts at output  
Output impedance: below 1 ohm  
Input resistance: 10 megohms  
10th decade steps over a 4-decade range

Model 6370-L6 (illustrated) is a linear phase, low-pass, 6th order filter. Phase is linear in the range dc to  $2\frac{1}{2}$  times the cut-off frequency. All Dynamics filters are compatible with other Dynamics signal conditioning equipment. Write for literature on this model, or on the entire line of electronic filters.

**DYNAMICS** INSTRUMENTATION COMPANY  
583 Monterey Pass Rd., Monterey Park, Calif. • Phone: CU. 3-7773

66 CIRCLE 66 ON READER SERVICE CARD

Erie Resistor Corp. for 13 years, and for the past 5 years has been general manager of its Elgin Laboratories division.

## Oak Expanding Elkhorn Plant

OAK MANUFACTURING CO., Crystal Lake, Ill., has announced an expansion program for its Elkhorn, Wisc., television tuner facility which will increase employment by 300 to 400 workers in early 1964.

Construction has started on a new plant which will increase Elkhorn's manufacturing space by 35 percent. Currently, the company employs about 900 workers in its 50,000-sq-ft plant there.



## IBM Announces Executive Changes

INTERNATIONAL BUSINESS MACHINES Corporation has announced the following executive changes:

J. A. Haddad (picture) has been named director of technology and engineering for the corporation. He was vice president of the Data Processing division.

C. R. DeCarlo, formerly director of education, has been named director of the systems research and development department.

G. H. Rathe Jr. succeeds DeCarlo as director of education for the corporation. He was director of executive development.

## Belock Instrument Appoints Humbert

BELOCK INSTRUMENT Corporation, College Point, N. Y., has announced the appointment of John L. Hum-

December 13, 1963 electronics



**WANT  
TO DO  
BUSINESS  
WITH THE  
GOVERNMENT**

????????????

Then check the Military and Government Procurement Guide in the orange section of your **ELECTRONICS BUYERS' GUIDE**.

!!!!!!!!!!!!!!!!!!!!

**DIGI EC** NEW **LOW COST  
AC/DC DVM**



"Z-210" DC-DVM  
*.1% Accuracy*

**\$650<sup>00</sup>**  
COMPLETE AS SHOWN

"910" AC/DC  
CONVERTER  
*.3% Accuracy*

4 Ranges: 0-1,000, 10.00, 100.0 and 1000. Volts DC

Available separately in Portable or Panel Models

**Offering a complete facility for accurate measurements of either AC or DC voltage.**

**UNITED SYSTEMS CORPORATION**  
918 Woodley Road, Dayton 3, Ohio (213) 254-3567

*Stocking Representatives Throughout the United States, England and Canada*

CIRCLE 208 ON READER SERVICE CARD

**TO ORDER REPRINTS**

Fill in, cut out coupon below  
insert in envelope and mail to:

**electronics** Reprint Dept.  
330 W. 42nd Street, New York, N. Y. 10036

**REPRINT ORDER FORM**

(To help expedite mailing of your reprints please send cash, check or money order with your order.)

For Listing of Reprints Available see the Reader Service Card.

For Reprints of the latest Special Report:  
**What's New in Semiconductors**

Send me.....Reprints of Key No. **R-45** 1-10, copies 75¢ ea. 10-24, 60¢ ea. 25 or more 50¢ ea.

For Reprints of previous **Special Reports** or **Feature Articles** fill in below:

Send me.....Reprints of Key No.(s).....@.....¢ each.  
(For prices, see Reader Service Card.)

\*For orders of **Bulk Reprints** of other editorial articles in this issue or past issues:

Send me....Reprints of page No.(s)....of issue date....  
of article entitled.....

\*Minimum bulk order 100 copies. You will be advised of costs by return mail.

Name .....

Number of Street .....

City, Zone No., State .....

**From Aluminum  
to Alcohol**

Some folks solve aluminum plating problems by turning to alcohol. That's silly. Getting plastered is no substitute for getting plated.

Cork the bottle, fellows, and bring your aluminum plating problems to us. Our equipment and techniques have made possible dramatic breakthroughs in achieving specifications deposits that are capable of withstanding the most severe environmental, soldering and mechanical requirements.

We're solving difficult aluminum plating problems right now for people you know. This permits them to spend their time more efficiently . . . drinking toasts to victory.

You can too. Skol.

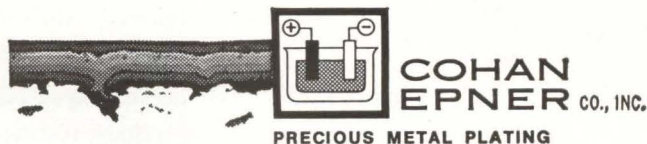

Dept. 4e, 142 West 14th Street, New York City 11, N.Y.



# FREE TO COMPANY OFFICIALS LOOKING FOR A NEW PLANT SITE

WE WILL PREPARE FOR YOU A  
**CONFIDENTIAL SURVEY**  
OF SELECTED LOCATIONS  
FOR YOUR NEW PLANT IN  
**NEW YORK STATE**

## TABLE OF CONTENTS

SUBJECT	PAGES
Introduction .....	1
Growth Trends .....	2-3
Climate .....	4-6
Public Utilities .....	7-22
Financial .....	23
Government Services.....	24-44
Taxes	
Protective Services	
Water Supply & Sewerage	
Community Facilities .....	45-73
Housing	
Education	
Recreation & Culture	
Industrial History .....	74-79
Labor .....	80-92
Natural Resources .....	93-94
Transportation & Markets..	95-104
Sites .....	105-133

**TAILOR-MADE.** This confidential report is not taken off the shelf. It will be prepared specifically for you, based on the requirements for your new plant as you give them to us. Send these requirements on your business letterhead to Commissioner Keith S. McHugh, N.Y. State Dept. of Commerce, Room 255R, 112 State St., Albany 7, N.Y.

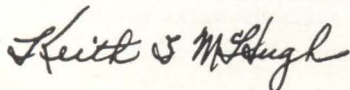

Keith S. McHugh, Commissioner  
New York State Department of Commerce

bert as director of manufacturing operations. He was formerly works manager of the integrated Industrial and Military division of Allen B. DuMont Laboratories, a division of Fairchild Camera and Instrument.

Belock produces electronic and electromechanical systems and components.

## PEOPLE IN BRIEF

**David J. Houck** promoted to v-p, mfg., of Electronic Modules Corp. **Richard S. Rothschild** advances to mgr. of electronic products at General Applied Science Laboratories, Inc. **Charles R. Toye**, formerly with Philco Corp., appointed mgr. of reliability at Transitron Electronic Corp. **Seymour Levine** moves up to mgr. of field engineering and project planning for Silicon Transistor Corp. **Lowell L. Wilkes** elevated to v-p, marketing, at Cambridge Thermionic Corp. **Walter P. Dyke**, president of Field Emission Corp., named a director of Tektronix, Inc. **Renzo Dallimonti** raised to mgr. of planning for the Philadelphia div. of Honeywell's Industrial Products Group. **Richard F. Tullius**, previously with GE, appointed engineering supervisor for Continental Electronics Products Co. **Herman Schkolnick** promoted to mgr. of the electro-visual products dept. of Fairchild's DuMont Laboratories. **Edward T. Connor**, v-p of marketing, takes added post of exec asst. to the president at Instrument Development Laboratories, Inc. **John Vetrano**, from Allied Control to Relaymatic Inc. as v-p of engineering. **Eugene D. Stirlen**, former v-p, elected chairman of the board of Laboratory For Electronics, Inc. **James N. Hills** moves up to director, organization and controls for ITT Corp. **Harry J. Dietrick** advances to mgr. of aerospace and industrial products research at B. F. Goodrich Co.'s Research Center. **Daumant "Del" Kusma** leaves Philco Corp. to join International Resistance Co. as director of operations.

## EMPLOYMENT OPPORTUNITIES



The advertisements in this section include all employment opportunities—executive, management technical, selling, office, skilled manual, etc. Look in the forward section of the magazine for additional Employment Opportunities advertising.

### — RATES —

**DISPLAYED:** The advertising rate is \$40.17 per inch for all advertising appearing on other than a contract basis. Contract rates quoted on request.

An advertising inch is measured 7/8" vertically on a column—3 columns—30 inches to a page.

Subject to Agency Commission.

**UNDISPLAYED:** \$2.70 per line, minimum 3 lines. To figure advance payment count 5 average words as a line.

**Box numbers**—count as 1 line.

**Discount of 10%** if full payment is made in advance for 4 consecutive insertions. Not subject to Agency Commission.

## ENGINEER

### Industrial Instrumentation & Control Devices

We are offering a growth opportunity for an outstanding engineer with B.S. or M.S. degree in electrical engineering and up to 5 years experience. Development and design of electromechanical and electronic equipment and circuitry from inception to production design.

Please send resume in confidence to F. Sheridan

## WALLACE & TIERNAN, INC.

25 Main Street, Belleville, N. J.

An equal opportunity employer



## E. E.'s

for FEE-PAID Positions  
**WRITE US FIRST!**

Use our confidential application for professional, individualized service . . . a complete national technical employment agency.

**ATOMIC PERSONNEL, INC.**  
Suite 1207L, 1518 Walnut St., Phila. 2, Pa.

## PROFESSIONAL SERVICES

### GIBBS & HILL, Inc.

Consulting Engineers

Systems Engineering

Operations Research • Development  
Field Studies • Design • Procurement  
Power • Transportation • Communications  
Water Supply • Waste Treatment

393 Seventh Avenue New York 1, N. Y.



## SEARCHLIGHT SECTION

(Classified Advertising)

BUSINESS OPPORTUNITIES  
EQUIPMENT - USED or RESALE

### DISPLAYED RATE

The advertising rate is \$27.25 per inch for all advertising appearing on other than a contract basis. Contract rates quoted on request. AN ADVERTISING INCH is measured  $\frac{1}{8}$  inch vertically on one column, 3 columns—30 inches—to a page. EQUIPMENT WANTED or FOR SALE ADVERTISEMENTS acceptable only in Displayed Style.

### UNDISPLAYED RATE

\$2.70 a line, minimum 3 lines. To figure advance payment count 5 average words as a line.

PROPOSALS, \$2.70 a line an insertion.

BOX NUMBERS count as one line additional in undisplayed ads.

DISCOUNT OF 10% if full payment is made in advance for four consecutive insertions of undisplayed ads (not including proposals).

## CAPACITORS

MFD	VOLTS	PRICE	MFD	VOLTS	PRICE
*.025	50KV	29.50	† 2	6000V	\$19.50
.028	40KV	29.50	† 2	16KV	69.95
*.2	50KV	64.50	3	20KV	125.00
†.25	15KV	17.95	5	10KV	70.50
†.25	32.5KV	44.50	9	10KV	115.00
† 1	7500V	8.00	† 10	5000V	40.00
† 1	15KV	44.50	† 15	5000V	35.00
† 2	25KV	45.00	75	6000	69.00
† 2	10KV	54.00			

— SPECIAL —

32 mfd—600V		\$3.50
1 mfd—300V CP08A1KD105K		.29
6 mfd—150V Bathub		.35
10 mfd—100V Bathub		.59
18 mfd—150V Bathub		.89

\* Case Common. † Large qua. available.  
Write for complete listing

### MONMOUTH RADIO LABS.

BOX 247 OAKHURST, N. J.  
CAPITOL 2-0121 ART HANKINS, Prop.

CIRCLE 955 ON READER SERVICE CARD

### SMALL AD but BIG STOCK

of choice test equipment  
and surplus electronics

Higher Quality—Lower Costs  
Get our advice on your problem

ENGINEERING ASSOCIATES

434 Patterson Road — Dayton 19, Ohio

CIRCLE 956 ON READER SERVICE CARD

## FREE...CATALOG BARRY ELECTRONICS

512 BROADWAY 212-WAlker 5-7000  
NEW YORK 12, N.Y. TWX-571-0484

CIRCLE 957 ON READER SERVICE CARD

### ELECTRON TUBES

KLYSTRONS • ATR & TR • MAGNETRONS  
SUBMINIATURES • C.R.T. • T.W.T. • 5000-  
6000 SERIES

• SEND FOR NEW CATALOG A2 •

A & A ELECTRONICS CORP.  
1063 PERRY ANNEX  
WHITTIER, CALIF.  
AN 92865 OR 943-2829

CIRCLE 958 ON READER SERVICE CARD

### Color DIAL TELEPHONES \$10.95

Factory rebuilt Western Electric  
in white, beige, ivory, pink, green,  
or blue. If 2 prong plug is re-  
quired add \$2.00. Fully guaranteed.  
Write for free list. All ship-  
ments FOB.

Complete



SURPLUS SAVING CENTER  
Waymart Dept. E-11863 Penna.

CIRCLE 959 ON READER SERVICE CARD

## WORRIED ABOUT RELAYS?



RELAX . . . we have  
2,000,000  
to choose from  
ALL TYPES • MOST MAKES  
order from  
**UNIVERSAL RELAY'S**  
Catalogue E  
FREE ON REQUEST  
IMMEDIATE SERVICE  
PRODUCTION QUANTITIES IN STOCK

**Universal RELAY CORP.**

42A White St., New York 13, N. Y., WA 5-6900

CIRCLE 952 ON READER SERVICE CARD

## No-Drip

### POTTING APPLICATORS

For encapsulating  
pottng and sealing  
of miniature and  
subminiature  
components

6 cc  
12 cc  
30 cc



FEATURES  
• Low Cost  
• Simple Operation  
• Absolutely Clean

**PHILIP FISHERMAN CO.**  
7 CAMERON ST., WELLESLEY 81, MASSACHUSETTS  
PHONE: 237-0133 AREA CODE: 617

CIRCLE 953 ON READER SERVICE CARD

## WANTED

Electronic Parts and Equipment.  
May be complete or incomplete.

Writing giving quantity  
and description.

### OLSON ELECTRONICS, INC.

Irving K. Olson Tel. JE 5-9191  
260 E. Forge St., Akron 8, Ohio

CIRCLE 954 ON READER SERVICE CARD

### WANTED

WHERE can I buy 400 Sylvania  
D2200 diodes?

Write S. B. GRAY,  
219 West 81 St., New York 24, N. Y.

CIRCLE 960 ON READER SERVICE CARD

## AUTOTRACK ANTENNA MOUNT

### TYPE SCR 584, MP 61B

360 degree azimuth, 210 degree elevation sweep  
with better than 1 mil. accuracy. Missile velocity  
acceleration and slewing rates. Amplidyne and servo  
control. Will handle up to 20 ft. dish. Supplied  
complete with control chassis. In stock—immediate  
delivery. Used world over by NASA, ABMA, USAF.

### AIRBORNE AUTOTRACK X-Y MOUNT

Gimbal mount, compl. w/all servos & drives for  
full sweep. \$475.

### SCR 584 RADARS AUTOMATIC TRACKING 3 CM & 10 CM

Our 584s in like new condition, ready to go, and in  
stock for immediate delivery. Ideal for telemetry  
research and development, missile tracking, satellite  
tracking, balloon tracking, weather forecasting, anti-  
aircraft defense tactical air support. Used  
on Atlantic Missile Range, Pacific Missile Range,  
N.A.S.A. Wallops Island, A.B.M.A. Desc. MIT Rad.  
Lab. Compl. inst. bk. available \$25.00 ea. Series,  
Vol. 1, pps. 207-210, 228, 284-286.

### PULSE MODULATORS

#### MIT MODEL 9 PULSER

##### 1 MEGAWATT—HARD TUBE

Output 25 kv 40 amp. Duty cycle, .002. Pulse lengths  
.25 to 2 microsec. Also .5 to 5 microsec. and .1 to .5  
msec. Uses 6C21. Input 115v 60 cycle AC. Mfr. GE.  
Complete with driver and high voltage power supply.  
Ref: MIT Rad. Lab. Series Vol. 5 pps. 152-160.

##### 500KW THYRATRON PULSER

Output 22kv at 28 amp. Rep. rates: 2.25 microsec.  
300 pps, 1.75 msec 550 pps, .4 msec 2500 pps. Uses  
5C22 hydrogen thyatron. Complete with driver and  
high voltage power supply. Input 115v 60 cy AC.

##### 2 MEGAWATT PULSER

Output 30 kv at 70 amp. Duty cycle .001. Rep rates:  
1 microsec 600 pps, 1 or 2 msec 300 pps. Uses 5948  
hydrogen thyatron. Input 120/208 VAC 60 cycle.  
Mfr. GE. Complete with high voltage power supply.

##### 15KW PULSER—DRIVER

Biased multivibrator type pulse generator using 3E29.  
Output 3kv at 5 amp. Pulse lgths .5 to 5 microsec,  
easily adj. to .1 to .5 msec. Input 115v 60 cy AC.  
\$475. Ref: MIT Rad. Lab. Series Vol. 5 pps. 157.

##### MIT MODEL 3 PULSER

Output: 144 kw (12 kv at 12 amp.) Duty ratio: 001  
max. Pulse duration: 5.1 and 2 microsec. Input:  
115 v 400 to 2000 cps and 24 vdc. \$325 ea. Full  
desc. Vol. 5 MIT Rad. Lab. series pg. 140.

### MICROWAVE SYSTEMS

#### 300 TO 2400MC RF PKG.

300 to 2400MC CW. Tuneable. Transmitter 10 to 30  
Watts. Output. As new \$475.

#### X BAND DOPPLER SYSTEM

AN/APN-102 G.P.L. ANT/RCYR/XMTR PKG. 4  
Beam Pulsed Janus Planar Array—New \$1600.

#### AN/TPS-ID RADAR

500 kw 1220-1359 mcs. 160 nautical mile search range  
P.P.I. and A Scopes. MTI. thyatron mod. 5J26  
magnetron. Complete system.

#### 10 CM. WEATHER RADAR SYSTEM

Raytheon, 275 KW output S Band. Rotating yoke  
P.P.I. Weather Band. 4, 20 and 80 mile range. 360  
degree azimuth scan. Supplied brand new complete  
with instruction books and installation drawings.  
Price \$975 complete.

#### AN/APS-15B 3 CM RADAR

Airborne radar. 40 kw output using 725A magnetron.  
Model 3 pulser. 30-in. parabola stabilized antenna.  
PPI scope. Complete system. \$1200 each. New.

#### 10KW 3 CM. X BAND RADAR

Complete RF head including transmitter, receiver,  
modulator. Uses 2J42 magnetron. Fully described in  
MIT Rad. Lab. Series Vol. I, pps 616-625 and Vol.  
II, pps. 171-185 \$375. Complete System. \$750.

#### AN/APS-27 X BAND RADAR

Complete 100 kw output airborne system with AMTI,  
5C22 thyr. mod, 4J52 magnetron, PPI, 360 deg az  
sweep, 60 deg. elev. sweep, gyro stabilizer, hi-gain  
revr. Complete with all plugs and cables \$2800.

#### M-33 AUTO-TRACK RADAR SYSTEM

X band with plotting board, automatic range track-  
ing, etc. Complete in 2 van complex incl. 1 mega-  
watt acquisition radar.

#### AN/APS-45 HEIGHT FINDER

Airborne system, 40,000 ft. altitude display on PPI  
& RHI. 9375 mcs. 400kw output using QK-172  
magnetron, 5622 thyatron.

#### L BAND RF PKG.

20 KW peak 990 to 1040 MC. Pulse width .7 to 1.2  
microsec. Rep rate 180 to 420 pps. Input 115 vac.  
Incl. Receiver \$1200.

#### 200MC RF PKG

175 to 225 mc. Output: 200 to 225 kw. 5 microsec 60  
pps. Input: 115v 60 cycle AC. \$750.

#### AN/UKR-5A TELEMETRY SET

Mfr. Raymond Rosen Eng'g Co. 215-235 mc re-  
ceiving terminal with recorders. \$2400.00

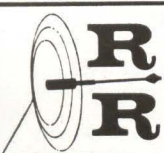

**Radio-Research  
Instrument Co.**

550 5th Ave. New York 36, N. Y.  
Tel. JUdson 6-4691

CIRCLE 951 ON READER SERVICE CARD



# INDEX TO ADVERTISERS

- AMP Incorporated ..... 24
- Acromag Inc. .... 66
- Atlanta Chamber of Commerce 65
  
- Baldwin-Lima-Hamilton, Elec-  
tronics Div. .... 53
- Burroughs Corporation  
Electronic Components Div. . . 9
- Bussmann Mfg. Co.  
Div. of McGraw Edison Co. . .  
60, 61
  
- Cannon Electric Inc.  
Sub. of ITT ..... 13
- Chase Manhattan Bank, The . . . 21
- Christie Electric Corp. .... 62
- Cohan Epner Co., Inc. .... 67
- Communication Electronics Inc. 62
- Consolidated Electrodynamics  
Corp. .... 44, 45
  
- Delta Electronics Inc. .... 57
- Di Acro Corp. .... 63
- Dymec,  
A Division of Hewlett-Packard  
Co. .... 12
- Dynamics Instrumentation Co. . 66
  
- Eisler Engineering Co., Inc. . . . 57
  
- Filters Inc. .... 23
- Flying Tiger Line ..... 5
- Ford Instrument Co. .... 64
- Div. of Sperry Rand Corp. . . .
  
- General Products Corp. .... 8
- Globe Industries Inc. .... 61
  
- Hamilton Standard  
Div. of United Aircraft Corp. . 4
- Hewlett-Packard Company  
inside front cover
- Hexacon Electric Co. .... 57
- Hughes Aircraft Co.  
Aerospace Divisions ..... 59

- Kepco, Inc. .... 47
- Kin Tel  
A Division of Cohu Electronics  
Inc. .... 3rd cover
- Krohn-Hite Corp. .... 11
  
- Lapp Insulator Co., Inc. .... 43
- Lear Siegler Inc. .... 56
- Lockheed Missiles & Space Co. 22
  
- Marconi Instruments ..... 51
- Melpar Inc. .... 45
- Microwave Associates Inc. .... 41
  
- New York State Dept.  
of Commerce ..... 68
- North Atlantic Industries, Inc. 49
  
- Pennsalt Chemicals Corp. .... 7
- Precious Metal Plating  
Div. of Chemical Plating Co. 50
  
- Radio Corporation of America  
4th cover
  
- Sprague Electric Co. .... 3, 6
- Struther-Dunn Inc. .... 16
- Synthane Corp. .... 51
  
- Texas Instruments Incorporated  
Industrial Products Group. .... 52
  
- United Systems Corp. .... 67
  
- Vacuum Electronics Corp. .... 42
  
- Weston Instruments & Electronics  
A Division of Daystrom  
Inc. .... 54, 55
- White S. S. .... 48

**CLASSIFIED ADVERTISING**  
F. J. Eberle, Business Mgr. (2557)

**PROFESSIONAL SERVICES** ..... 68

**EMPLOYMENT OPPORTUNITIES** . . 68

**EQUIPMENT**  
(Used or Surplus New)  
For Sale ..... 69

**WANTED**  
Equipment ..... 69

**CLASSIFIED ADVERTISERS INDEX**

- Atomic Personnel Inc. .... 68
- Barry Electronics ..... 69
- Engineering Associates ..... 69
- Fishman Co., Philip. .... 69
- Gray, S. B. .... 69
- Monmouth RadioLabs ..... 69
- Olson Electronics, Inc. .... 69
- Radio Research Instrument Co. 69
- Surplus Saving Center ..... 69
- Universal Relay Corp. .... 69
- Wallace & Tiernan Inc. .... 68

• See advertisement in the July 25, 1963 issue of electronics Buyers' Guide for complete line of products or services.

This Index and our Reader Service Numbers are published as a service. Every precaution is taken to make them accurate, but **electronics** assumes no responsibilities for errors or omissions.

## electronics



Audit Bureau  
of Circulation



Associated Business  
Publications

**AUDITED PAID CIRCULATION**

**JAMES T. HAUPTLI (2210)**  
Advertising Sales Manager

**HENRY M. SHAW (3485)**  
Market Research Manager

**DAVID M. TEMPEST (3139)**  
Promotion Manager

### electronics Buyers' Guide

**R. S. QUINT (2335)**  
General Manager

**RICHARD J. TOMLINSON (3191)**  
Business Manager

**THEODORE R. GEIPEL (2044)**  
Production Manager

**NEW YORK TELEPHONE: Dial Direct:**  
971 plus number in parenthesis,  
Area Code 212

### ADVERTISING REPRESENTATIVES

**ATLANTA, GA. 30309**  
Michael H. Miller, Robert C. Johnson  
1375 Peachtree St. N.E.,  
Trinity 5-0523 (area code 404)

**BOSTON, MASS. 02116**  
William S. Hodgkinson  
McGraw-Hill Building, Copley Square,  
Congress 2-1160 (area code 617)

**CHICAGO, ILL. 60611**  
Harvey W. Wernecke,  
Robert M. Denmead  
645 North Michigan Avenue,  
Mohawk 4-5800 (area code 312)

**CLEVELAND, OHIO 44113**  
Paul T. Fegley  
55 Public Square, Superior 1-7000  
(area code 216)

**DALLAS, TEXAS 75201**  
Frank Le Beau  
The Vaughn Bldg.,  
1712 Commerce St.  
Riverside 7-9721 (area code 214)

**DENVER, COLO. 80202**  
John W. Patten  
Tower Bldg., 1700 Broadway,  
Alpine 5-2981 (area code 303)

**HOUSTON, TEXAS 77025**  
Kenneth George  
Prudential Bldg., Halcombe Blvd.,  
Riverside 8-1280 (area code 713)

**LOS ANGELES, CALIF. 90017**  
Ashley P. Hartman, John G. Zisch,  
1125 W. 6th St., Huntley 2-5450  
(area code 213)

**NEW YORK, N. Y. 10036**  
Donald H. Miller (212) 971 3615  
George F. Werner (212) 971 3617  
Donald R. Furth (212) 971 3616  
500 Fifth Avenue

**PHILADELPHIA, PA. 19103**  
Warren H. Gardner, William J. Boyle  
6 Penn Center Plaza,  
LOcust 8-4330 (area code 215)

**SAN FRANCISCO, CALIF. 94111**  
Richard C. Alcorn  
255 California Street,  
Douglas 2-4600 (area code 415)

**LONDON W1:**  
Edwin S. Murphy Jr.  
34 Dover St.

**FRANKFURT/Main:**  
Mathee Herfurth  
85 Westendstrasse

**GENEVA:**  
Michael R. Zeynel  
2 Place du Port

**TOKYO:**  
George Olcott,  
1, Kotohiracho, Shiba, Minato-ku



**KIN TEL**

**world's  
largest  
DC amplifier  
manufacturer**

**has an  
amplifier  
to fit  
your**

**requirements**



### **Solid state, non inverting amplifier**

Model 121A/A. Response from DC to beyond 200 kc. Input impedance >10 megohms; output capability  $\pm 15$  volts, 100 ma; output impedance <0.2 ohm in series with 50 microhenries. Price: \$1000.

### **Floating, differential amplifier**

Model 114C. High common mode rejection, low effective input capacity. DC to 85 cps. Input impedance >40 megohms; output capability  $\pm 10$  volts, 10 ma; output impedance <0.25 ohm to 500 cps; <1 ohm to 2 kc. Price: \$995.

### **Floating, differential amplifier**

Model 114A. Effective input capacity less than  $1\mu\text{mfd}$ , high common mode rejection. 100 cycle bandwidth. Input impedance >5 megohms. Output capability  $\pm 10$  volts, 10 ma; output impedance <2 ohms, DC to 1 kc. Price: \$895.

### **Wideband amplifier**

Model 112A. Four different plug-in attenuator units. DC to 40 kc. Input impedance 100 K ohms; output capability  $\pm 35$  volts, 40 ma; output impedance <1 ohm in series with 25 microhenries. Prices: \$575 to \$680.

All KIN TEL DC data amplifiers: have drift less than  $2\mu\text{v}$  • accuracy of 0.01% for any single gain step • fit six to a standard 19-inch rack • are available in portable cabinets • have an integral power supply • are chopper-stabilized • have exceptional linearity and low output impedance.

All prices FOB, San Diego, California. (Additional export charge.)  
Write for detailed information. Representatives in all major cities.

CIRCLE 901 ON READER SERVICE CARD

5725 Kearny Villa Road  
San Diego, California 92112  
Phone (714) 277-6700







**7" Direct-View DST—RCA-C73983**—The ability to store information for many seconds at initial brightness levels makes the C73983 highly suitable for use in display systems employing very slow scanning speeds such as long-range radar, slow-scan TV, and sonar. A selective erasing feature permits the displayed information to be retained at full brightness until it is to be replaced by new information. The C73983 provides a 5¼-inch-diameter display having sufficient brightness to permit viewing in well-lighted areas.

**10" Direct-View DST—RCA-4412**—The ability to store information for many seconds while continuously presenting it in a large non-flickering display makes the 4412 a highly recommended tube for special electronic display systems. The range of possible applications in which the 4412 may be used is extended to the most sophisticated military-airborne equipment by an extremely rugged tube structure.

**5" Direct-View DST—RCA-7268**—High brightness and an adjustable rate of information decay make the 7268 highly useful for the display of information under daylight-viewing conditions in airborne fire-control radar systems. This tube provides a full 4-inch-diameter display having excellent uniformity and positional accuracy under the severe environmental conditions encountered in airborne military equipment.

## RCA DISPLAY STORAGE TUBES

### A Line Tailored to Your Application

Reliability, high resolution, and writing speeds tailored to your application make RCA Display Storage Tubes ideal for data readout, sonar, radar, or your special electronic display system. Offering a wide choice of levels of brightness and resolution in half-tone display, most of these tubes are ruggedly designed to withstand severe environmental conditions of altitude, temperature, humidity, vibration, and shock.

RCA's Display Storage Tube line offers you a choice of display area, single or multiple writing guns, and electrostatic or magnetic deflection. Ask about them locally at your authorized RCA Industrial Tube Distributor.

**RCA FIELD OFFICES—OEM SALES:** Newark 2, N. J., 32-36 Green St., (201) 485-3900 • Chicago 54, Ill., Suite 1154, Merchandise Mart Plaza, (312) 527-2900 • Los Angeles 22, Calif., 6801 E. Washington Blvd., (213) RA 3-8361 • **GOVERNMENT SALES:** Harrison, N. J., 415 South Fifth St., (201) 485-3900 • Dayton 2, Ohio, 224 N. Wilkinson St., (513) BA 6-2366 • Washington 6, D. C., 1725 "K" St., N.W., (202) FE 7-8500 • **INTERNATIONAL SALES:** RCA International Div., Clark, N. J., (201) 382-1000

**ALSO AVAILABLE FROM YOUR AUTHORIZED RCA INDUSTRIAL TUBE DISTRIBUTOR**

#### SEND FOR NEW RCA DISPLAY STORAGE TUBE BOOKLET, 1G1144

This booklet, 1G1144, contains information on RCA's Display Storage Tube line. It is available by writing: Commercial Engineering, Section I-19-Q-2, RCA Electronic Components and Devices, Harrison, N. J.

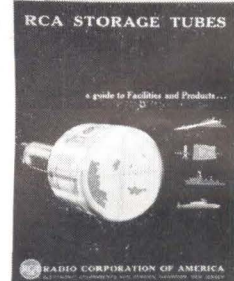

The Most Trusted Name in Electronics