

Model
800C
Logic Analyzer
VOLUME 1
Operator's Manual

 Nicolet

Nicolet Paratronics Corporation
201 Fourier Avenue
Fremont, California 94539 USA
415-490-8300

P/N 125-0052-0001

February, 1985

©1984 Nicolet Paratronics Inc., all rights reserved
Litho in U.S.A.

CERTIFICATE OF COMPLIANCE

Nicolet Paratronics Corporation certifies that this instrument complied with all published specifications at the time of shipment from the factory.

Nicolet reserves the right to enhance or modify this model with no obligation to provide these enhancements or modifications to previous buyers.

LIMITED WARRANTY

Nicolet Paratronics Corp. ("NPC") guarantees your analyzer instrument against all defects in materials and workmanship for a period of one (1) year from the date of delivery to the original user. All instruments returned to NPC FREIGHT PREPAID during the one year period will be replaced or restored to proper working condition and returned to the sender without charge. We neither assume nor authorize any representative or other person to assume of us any liability in connection with the sale on any shipment of our products.

NOTE

This warranty does not apply to damage caused by shipping, negligence, accident, unauthorized repair, abuse, misuse, or modification; or to inconveniences or consequential damages occasioned by the instrument, or by breach of any expressed or implied warranty in any way whatsoever will be binding upon NPC unless executed by a duly authorized officer of the company.

This warranty gives you specific legal rights, and you may also have other rights which depend on local jurisdiction.

We reserve the right to make changes and improvements in our products without incurring any obligation to similarly alter products previously purchased.

CAUTIONS

1. BEFORE APPLYING POWER to the NPC-800C, make certain that the Programmable AC Voltage Selector Card, which plugs into the power module at the rear of the unit, is inserted in the position corresponding to the line voltage being used.

Also make certain that the PROPER FUSE IS INSTALLED. The correct fuse value for each voltage is printed on the back of the instrument, near the fuse holder.

Otherwise, serious damage to the internal switching power supply may occur.

2. DO NOT OPERATE this instrument WITH THE TOP COVER REMOVED, as cooling is reduced and may cause component failure.

3. All service other than that detailed in Section 4 should only be performed by trained maintenance personnel.

TECHNICAL ASSISTANCE

Applications and service engineers are available should you need assistance with your instrument.

In Massachusetts, Maine, Connecticut, Rhode Island, and New Hampshire call 617-664-0355.

In California call 415-490-8300.

Elsewhere in the USA call 800-NICOLET (800-642-6538).

Outside the USA, call your nearest Nicolet Paratronics Sales office.

HOW TO USE THIS MANUAL

This manual has been organized to provide as much information as practical and to help you find any specific item of interest.

If this is the first time you have used a Nicolet Paratronics' logic analyzer, we suggest that you at least scan Sections 1 and 2, General Information and Preparation for Use. Then proceed to Section 3 which provides step-by-step instruction for using each feature of your NPC-800C.

If you are already a user of Nicolet Paratronics' logic analyzers and merely need guidance in the operation of this specific model, refer to Section 3.

If you suspect that you are having equipment failure problems, Section 4 contains preliminary service and troubleshooting hints. Detailed service information is contained in the Maintenance Manual.

Section 5 provides some assistance if you have purchased an option that was not installed at the factory.

Since there is not yet a "universal definition" for many of the terms related to logic analysis, Section 6, the Glossary, was created to help reduce confusion.

Sections 7 and 8 are for safe-keeping of information related to your logic analyzer: Application Notes and User Instructions for any dedicated probes that you may purchase.

SECTION	TITLE	PAGE
1	GENERAL INFORMATION	1-1
	1.1 INTRODUCTION	1-1
	1.2 SYSTEM DESCRIPTION	1-2
	1.2.1 Easy Operation	1-3
	1.2.2 Rapid Set-Up	1-3
	1.2.3 Logic State Analyzer	1-5
	1.2.3.1 Software Analysis	1-6
	1.2.3.2 Collection Clock Qualified Data	1-6
	1.2.3.3 Multiphase Clocking	1-8
	1.2.3.4 Triggering	1-8
	1.2.3.5 State Analysis — Only One Part Of The Electronic Workbench	1-9
	1.2.3.6 Additional Time-Saving Features	1-10
	1.2.4 Independent Timing Analyzer	1-10
	1.2.4.1 Powerful Hardware Analysis	1-11
	1.2.4.2 Advanced Triggering	1-11
	1.2.4.3 Complex Timing Measurements Made Easy	1-12
	1.2.4.4 Comparison Testing	1-13
	1.2.4.5 High Speed Collecting	1-13
	1.2.4.6 Timing Memory Reconfiguration	1-13
	1.2.4.7 Keyboard	1-13
	1.2.4.8 Alphabetic Keys	1-14
	1.2.4.9 Nonalphabetic Keys	1-14
	1.2.4.10 Nondisplayable Keys	1-15
	1.2.4.11 Special Keys (F1-F6, LABELS, RESET)	1-15
	1.3 ACCESSORIES SUPPLIED	1-16
	1.3.1 General Purpose Probes	1-16
	1.3.2 Basic Equipment	1-17
	1.4 OPTIONS DESCRIPTIONS	1-18
	1.4.1 Nonvolatile Memory	1-18
	1.4.2 Diskette	1-19
	1.4.3 Waveform Analyzer	1-19
	1.4.4 Powerful Analog Analysis	1-19
	1.4.5 Scope-Type Menu	1-19
	1.4.6 Easy Analog Measurements	1-20
	1.4.7 Cross-Domain Analysis	1-21
	1.4.8 Performance Monitoring	1-21
	1.4.9 Using Counter-Timer Plug-In	1-22
	1.4.10 Histograms	1-23
	1.4.11 Signature Analysis For Fault Isolation	1-25
	1.4.12 Model 70 For Bidirectional Serial Testing	1-27
	1.4.13 Eight-Bit and 16-Bit Dedicated Microprocessor Probes For Fast Software Debug	1-29
	1.4.14 Quick Connection	1-29
	1.4.15 Powerful Analysis Capabilities	1-30
	1.4.16 Advanced Analysis Capabilities	1-32
	1.4.17 NPC-800C — A General-Purpose Computer	1-32
	1.4.18 System Architecture	1-34
	1.4.19 CP/M Enhancement	1-34
	1.4.20 Post-Processing Analyzer Data	1-35
	1.4.21 The NPC-800C — A Low-Cost Development System	1-35

1.4.22	Automated Testing and Remote Control	1-36
1.4.23	Single I/O Menu Speeds GPIB and RS-232 Set-Ups	1-36
1.4.24	GPIB Controller/Device Applications	1-37
1.4.25	RS-232 Master/Slave Applications	1-37
1.4.26	The NPC-800C — An Electronic Workbench	1-38
1.5	Basic Logic Analysis System Specifications	1-38
2	PREPARATION FOR USE	2-1
2.1	INTRODUCTION	2-1
2.2	INITIAL INSPECTION	2-1
2.3	PRECAUTIONS	2-1
2.3.1	Equipment Handling	2-1
2.3.2	Programmable AC Voltage Selector Card	2-2
2.3.3	Handling of Diskettes	2-3
2.3.4	Write Protect Feature and Orientation	2-4
2.3.5	Technical Assistance	2-4
2.4	INITIAL SET-UP	2-4
2.4.1	Screen Adjustment	2-4
2.4.2	CRT Frame Rate Selection/50 Hz - 60 Hz	2-4
2.4.3	Frame Rate Select Switch	2-5
2.5	INTERCONNECTIONS	2-5
2.5.1	Input/Output Interface Ports	2-5
2.5.2	Probe Connections	2-5
2.5.3	External Video Out	2-6
2.5.4	RS-232C Serial Interface Port	2-6
2.6	PACKAGING FOR SHIPMENT	2-8
2.7	SHIPMENT	2-8
3	OPERATION	3-1
3.1	INTRODUCTION	3-1
3.1.1	Menus and Displays	3-1
3.1.2	Analysis Examples	3-2
3.1.3	Function Keys	3-3
3.1.4	Test Card Description	3-3
3.2	OPERATION MODES	3-4
3.2.1	Configuration Options	3-4
3.2.2	Configuration List Display	3-4
3.3	ON-LINE HELP	3-5
3.4	STATE ANALYSIS	3-7
3.4.1	State Probe Connections	3-7
3.4.2	State Logic Analysis Examples	3-7
3.4.3	48-Channel State Menu	3-7
3.4.4	To Call Menu	3-7
3.4.5	State Menu	3-8
3.4.6	Labels Key	3-8
3.4.7	Trigger (0040)	3-9
3.4.8	Display Formats	3-10
3.4.9	Mixed Display Format	3-11
3.4.10	Saving Data (S Key)	3-12
3.4.11	Signatures (SIG or Test Codes)	3-12
3.4.12	HOLD /= Mode (# Key)	3-12
3.4.13	Memsel (M Key)	3-13
3.4.14	Difference (/ Key)	3-13
3.4.15	LOCATE (F3)	3-13

3.4.16	Locate Difference (LOCATE D)	3-13
3.4.17	Locate End (LOCATE E)	3-15
3.4.18	Search Word (F4)	3-15
3.4.19	Configuration (F5)	3-16
3.4.20	Collect (F6)	3-16
3.4.21	Search Word	3-16
3.4.22	Pretrigger	3-18
3.4.23	Pretrigger Mechanism	3-20
3.4.24	Sequential Triggering	3-20
3.4.25	Collection Status	3-21
3.4.26	Force Display	3-22
3.4.27	Nonoccurrence Triggering	3-22
3.4.28	Auto-Restart	3-23
3.4.29	Force Trigger	3-23
3.4.30	Trigger Disable	3-23
3.4.31	Restart	3-23
3.4.32	Restart Example	3-24
3.4.33	Restart*	3-24
3.4.34	Collect	3-25
3.4.35	Restart	3-26
3.4.36	External Trigger Qualifiers	3-26
3.4.37	Trigger Qualifiers	3-26
3.4.38	Clock Qualification	3-27
3.4.39	First Clock Qualifier	3-27
3.4.40	Second Clock Qualifier	3-27
3.4.41	Clock Qualifier	3-27
3.4.42	Collect	3-28
3.4.43	Clock Select	3-29
3.4.44	Autocollect	3-29
3.5	TIMING ANALYSIS	3-29
3.5.1	Timing Analysis Examples	3-29
3.5.2	Setup	3-30
3.5.3	Initialize	3-30
3.5.4	16-Channel Timing Menu/1000 Words, 200 MHz Max.	3-30
3.5.5	Collection	3-31
3.5.6	Clock Speed	3-31
3.5.7	Timing Diagrams	3-32
3.5.8	User Prompts	3-32
3.5.9	Labels	3-32
3.5.10	Magnification	3-34
3.5.11	Trigger Location	3-34
3.5.12	-WINDOW, WINDOW- (F3, F4)	3-34
3.5.13	Expand (E)	3-35
3.5.14	Expansion Indicator (E)	3-36
3.5.15	-EXP, EXP- (F1, F2)	3-36
3.5.16	Cursor	3-36
3.5.17	Cursor Right, Cursor Left	3-36
3.5.18	Time Measurements Using Cursor and Origin (O)	3-37
3.5.19	Timing Display Manipulation	3-37
3.5.20	Display Order (0-7, X)	3-38
3.5.21	Display Polarity (+, -)	3-38
3.5.22	S2 4 (10X)	3-38
3.5.23	Names	3-39

3.5.24	Trigger	3-40
3.5.25	Arm and Trig	3-40
3.5.26	Triggering Modes	3-40
3.5.27	Pretrigger	3-41
3.5.28	Status Messages	3-41
3.5.29	Pretrigger Memory	3-42
3.5.30	Trigger Sequence	3-42
3.5.31	Correlation (K)	
	Change Clock Speed To 100 Milliseconds	3-43
3.5.32	Main/Aux Memory Compare (X)	3-44
3.5.33	Auto Collect	3-45
3.5.34	Edge Qualification	3-45
3.5.35	Using The Qualifier	3-46
3.5.36	Filter	3-48
3.5.37	Threshold	3-48
3.5.38	Input Mode	3-49
3.5.39	Sample	3-49
3.5.40	Latch	3-49
3.5.41	S1, S2	3-50
3.5.42	16-Channel State Display	3-50
3.5.43	Collect S1	3-50
3.5.44	Linkage	3-50
3.6	STATE AND TIMING ANALYSIS	3-51
3.6.1	Linking State to Timing	3-51
3.6.2	Collect	3-53
3.6.3	Linkage	3-53
3.6.4	Application	3-54
3.6.5	Disabling the L Bit	3-54
3.6.6	Linking Timing to State	3-54
3.6.7	Collect	3-55
3.7	GLITCH CAPTURE	3-55
3.7.1	Eight-Channel Glitch Memory Mode	3-55
3.7.2	Hardware	3-55
3.7.3	Setup	3-56
3.7.4	Connect	3-56
3.7.5	Collect S2	3-56
3.8	75MHz SYNCHRONOUS ANALYSIS	3-57
3.8.1	External Clock	3-57
3.9	FREQUENCY COUNTER/INTERVAL TIMER/SIGNATURE ANALYZER	3-59
3.9.1	CT/SA	3-59
3.9.2	Histograms	3-59
3.9.3	Basic Counter-Timer/(Optional CT/SA Board Must Be Installed)*	3-59
3.9.4	Counter-Timer Menus	3-60
3.9.5	To Call Up Menu	3-62
3.9.6	Explanation Of Menu	3-62
3.9.7	Basic Counter/Timer Example	3-63
3.9.8	Menu	3-63
3.9.9	Counter-Timer Display	3-64
3.9.10	Advanced Counter-Timer Example	3-64
3.9.11	State-Related Measurements	3-64
3.9.12	Frequency	3-65

3.9.13 Source: Data	3-65
3.9.14 Collect	3-65
3.9.15 Select	3-66
3.9.16 Interval Mode	3-66
3.9.17 Collect	3-66
3.9.18 Frequency	3-67
3.9.19 Period	3-67
3.9.20 Hold	3-68
3.9.21 Probe And Threshold	3-68
3.9.22 Basic Signature Analysis (Example)	3-68
3.9.23 Discussion	3-68
3.9.24 Signature Menu	3-69
3.9.25 To Call Up Menu	3-69
3.9.26 Explanation of Menu	3-70
3.9.27 To Setup Menu	3-70
3.9.28 Start/Stop	3-70
3.9.29 Signatures	3-71
3.9.30 Fault-Isolation	3-72
3.9.31 Advanced Signature Analysis (Example)	3-73
3.9.32 Software Signatures	3-73
3.10 ANALOG WAVEFORM RECORDER	3-73
3.10.1 Basic Waveform Analysis (Optional Waveform Analyzer Must Be Installed)*	3-74
3.10.2 Waveform Menu (1000 Words, 50 MHz)	3-74
3.10.3 To Call Up Menu	3-74
3.10.4 Explanation of Menu	3-75
3.10.5 Waveform (Example)	3-75
3.10.6 Clock (One Microsecond)	3-76
3.10.7 Collect	3-76
3.10.8 Waveform Display (1000 Words, 50 MHz)	3-77
3.10.9 Explanation of Waveform Display	3-77
3.10.10 Auto-Trigger	3-78
3.10.11 Advanced Waveform (Examples, Optional Waveform Board Must Be Installed)*	3-78
3.10.12 Waveform Mode	3-78
3.10.13 CLOCK (100 Nanoseconds)	3-79
3.10.14 Single-Shot Mode (W)	3-79
3.10.15 No Input Signal	3-80
3.10.16 Video Input	3-80
3.10.17 Expand	3-81
3.10.18 Waveform Display Magnification Concepts	3-82
3.10.19 Save (S)	3-83
3.10.20 Correlation (K) (Change Clock Speed to 100 Milliseconds)	3-84
3.10.21 Measurements	3-84
3.10.22 Aliasing	3-84
3.10.23 State Version Of Waveform Display	3-85
3.10.24 To Call Display	3-85
3.10.25 Explanation of State Version of Waveform Display	3-86
3.11 WAVEFORM AND STATE ANALYSIS	3-86
3.12 WAVEFORM AND TIMING ANALYSIS	3-93
3.13 WAVEFORM AND STATE AND TIMING ANALYSIS ..	3-95
3.14 NONVOLATILE MEMORY	3-98

3.15 PERFORMANCE ANALYSIS HISTOGRAMS	3-99
3.16 DOT MATRIX PRINTER	3-103
3.17 DEDICATED PROBES	3-104
3.17.1 Disassembly (Example)	3-104
3.17.2 "Disassembling" The Test Card	3-104
3.17.3 Collect	3-104
3.17.4 Loading Disassembly Software	3-105
3.17.5 Displaying In Disassembled Format	3-105
3.17.6 Unused State Channels	3-105
3.17.7 User Format (U)	3-106
3.17.8 Serial Analyzer	3-106
3.17.9 Available Dedicated Microprocessor Probes/Disassembly ..	3-107
3.17.10 Available Dedicated Bus Probes	3-107
3.17.11 General Purpose Interface Probe	3-107
3.17.12 Nicolet In-circuit Emulators (NICE)	3-107
3.18 COMPUTER/CONTROLLER	3-107
3.18.1 General-Purpose Computer	3-107
3.18.2 Hardware Display	3-107
3.18.3 Keyboard	3-108
3.18.4 Memory Subsystem	3-108
3.18.5 Disk Drive	3-108
3.18.6 I/O	3-108
3.18.7 Controller	3-108
3.18.8 Software	3-108
3.18.9 CP/M	3-109
3.18.10 CBASIC	3-109
3.18.11 CP/M Overview	3-109
3.18.12 Built-In Commands	3-109
3.18.13 Transient Commands	3-110
3.18.14 NPC Transient Commands CM2.COM	3-110
3.18.15 Secondary Configuration Menu	3-110
3.18.16 Files To Be Executed Using CBASIC Interpreter	3-112
3.18.17 CB-80, Compiled Basic	3-112
3.18.18 Files For Compilation By CB-80	3-112
3.18.19 Use of LASAVE and LARECALL From CBASIC Program	3-113
3.18.20 CP/M Examples	3-114
3.18.21 Power On	3-114
3.18.22 Header	3-114
3.18.23 STAT	3-114
3.18.24 ED	3-116
3.18.25 INSERT	3-117
3.18.26 TYPE	3-118
3.18.27 REN	3-118
3.18.28 ERA	3-118
3.18.29 FORMAT 1 AND FORMAT 2	3-118
3.18.30 ASM	3-119
3.18.31 .PRN FILE	3-120
3.18.32 .HEX FILE	3-121
3.18.33 EXECUTE	3-122
3.18.34 SUBMIT	3-122
3.18.35 Executing CP/M Commands	3-123
3.18.36 Executing Analyzer Tests	3-124
3.18.37 State Test	3-124

3.18.38	Timing Test	3-124
3.18.39	Waveform Test	
	(Optional Waveform Board Must Be Installed)*	3-125
3.18.40	Directory	3-125
3.18.41	Operator Prompts	3-125
3.18.42	Automatic Testing	3-125
3.18.43	PAUSE	3-125
3.18.44	AUTOTEST	3-126
3.19	IEEE-488 CONTROL	3-127
3.19.1	IEEE-488 Interface Controller	3-127
3.19.2	IEEE-488 Parallel Interface Port	3-128
3.19.3	Command Set Summary	3-128
3.19.4	ABORT GPIB	3-128
3.19.5	RESET	3-128
3.19.6	REMOTE	3-129
3.19.7	LOCAL	3-129
3.19.8	TRIGGER	3-129
3.19.9	REQUEST	3-129
3.19.10	OUTPUT	3-129
3.19.11	ENTER	3-129
3.19.12	STATUS	3-129
3.19.13	SET TIMEOUT	3-129
3.19.14	LOCAL LOCKOUT	3-129
3.19.15	CONFIGURE	3-129
3.19.16	EOI STATUS	3-129
3.19.17	SENBUS	3-130
3.19.18	TERM SEQ	3-130
3.19.19	Reference Documents	3-130
3.19.20	Abbreviations	3-130
3.19.21	General Discussion	3-131
3.19.22	Detailed GPIB Command Descriptions	3-131
3.19.23	I/O Configuration Menu	3-131
3.19.24	To Call Menu	3-131
3.19.25	Explanation Of Menu (GPIB Section)	3-132
3.19.26	Interface	3-132
3.19.27	Address	3-132
3.19.28	Mode	3-132
3.19.29	Termination Sequence	3-133
3.19.30	Talk Listen	3-133
3.19.31	Return Option	3-133
3.19.32	Transmission Inputs	3-133
3.19.33	Keyboard	3-133
3.19.34	GPIB	3-134
3.19.35	RS-232 and Memory	3-134
3.19.36	Transmission Outputs Section	3-134
3.19.37	CRT	3-134
3.19.38	GPIB	3-134
3.19.39	RS-232	3-134
3.19.40	Memory	3-135
3.19.41	GPIB Slave Address	3-135
3.19.42	Labels	3-135
3.19.43	Abort GPIB or INIT GPIB	3-135
3.19.44	Reset	3-136

3.19.45 Remote	3-136
3.19.46 Local	3-136
3.19.47 Trigger	3-137
3.19.48 Request	3-137
3.19.49 Output	3-137
3.19.50 Enter	3-138
3.19.51 Status	3-138
3.19.52 Set Timeout	3-139
3.19.53 Local Lockout	3-139
3.19.54 Configure	3-140
3.19.55 EOI Status	3-140
3.19.56 SENDBUS	3-140
3.19.57 TERM SEQ	3-140
3.19.58 GPIB Command Implementation Via CBASIC	3-141
3.19.59 ABORT GPIB Or INIT GPIB	3-141
3.19.60 RESET	3-141
3.19.61 REMOTE	3-142
3.19.62 LOCAL	3-143
3.19.63 TRIGGER	3-144
3.19.64 REQUEST	3-144
3.19.65 OUTPUT	3-145
3.19.66 ENTER	3-146
3.19.67 STATUS	3-147
3.19.68 SET TIMEOUT	3-148
3.19.69 LOCAL LOCKOUT	3-148
3.19.70 CONFIGURE	3-150
3.19.71 EOI STATUS	3-150
3.19.72 SENDBUS	3-151
3.19.73 TERMINATION SEQUENCE	3-152
3.19.74 Address/Data Formats For CBASIC	3-153
3.19.75 ADDRESS\$	3-153
3.19.76 ADDRESS.LIST\$	3-153
3.19.77 DATA\$	3-154
3.19.78 DATA.VARIABLE\$	3-154
3.19.79 STATUS.BYTE%	3-154
3.19.80 STATUS.VARIABLES	3-154
3.19.81 CBASIC Reserved Identifiers	3-155
3.19.82 Direct Use of GPIB Primitives	3-155
3.19.83 Address/Data Formats For Assembler Primitives	3-155
3.19.84 BIT	3-155
3.19.85 DATA (Bus Status)	3-156
3.19.86 Command Branch Index	3-156
3.19.87 Command Control Byte	3-156
3.19.88 Return Code	3-157
3.19.89 Level of GPIB Implementation	3-158
3.19.90 Command Formats	3-158
3.19.91 Commands That Return Data	3-158
3.19.92 Command Definitions	3-162
3.19.93 Transmission Examples (NPC-800C ONLY)	3-165
3.19.94 Analyzer Data Transmission	3-165
3.19.95 Controller (Master)	3-165
3.19.96 Device (Slave)	3-166
3.19.97 MORE I/O EXAMPLES	3-167

3.19.98	Source	3-167
3.19.99	GPIBEX	3-167
3.20	RS-232C REMOTE LOGIC ANALYSIS	3-172
3.20.1	Computer Control Via RS-232C	3-173
3.20.2	Interface Connections	3-173
3.20.3	RS-232C Pin Definitions	3-173
3.20.4	Interface Configuration	3-173
3.20.5	Control Register Command Register	3-173
3.20.6	RS-232C Setup	3-174
3.20.7	Default Baud Rate	3-176
3.20.8	Remote Control Example	3-176
3.20.9	Setup	3-176
3.20.10	I/O Configuration Menu	3-176
3.20.11	RS-232 Section Interface	3-177
3.20.12	Mode	3-177
3.20.13	Parity	3-178
3.20.14	Duplex	3-178
3.20.15	Word Length	3-178
3.20.16	Stop Bits	3-178
3.20.17	Transmission Inputs	3-178
3.20.18	Keyboard	3-178
3.20.19	GPIB	3-179
3.20.20	RS-232	3-179
3.20.21	Memory	3-179
3.20.22	Transmission Outputs Section	3-179
3.20.23	CRT	3-179
3.20.24	GPIB	3-179
3.20.25	RS-232	3-179
3.20.26	Memory	3-180
3.20.27	GPIB SLAVE ADDRESS*	3-180
3.20.28	LABELS	3-180
3.20.29	MENU Setup	3-180
3.20.30	TRANSMIT	3-181
3.20.31	RS-232	3-181
3.20.32	Commands That Return Data	3-182
3.20.33	Command Definitions	3-185
3.20.34	More I/O Examples	3-187
3.20.35	Source	3-187
3.20.36	RS232EX	3-187
3.20.37	Procedure Setup	3-188
4	SERVICE	4-1
4.1	INTRODUCTION	4-1
4.1.1	Air Filter Maintenance	4-1
4.2	PERFORMANCE VERIFICATION TESTS	4-1
4.2.1	Initialization	4-2
4.2.2	Basic State Analyzer Collection	4-2
4.2.3	Basic Timing Data Collection	4-3
4.2.4	Basic Waveform Collection (Option Must Be Installed)	4-4
4.2.5	Counter/Timer Collection	4-4
4.2.6	Signature Analyzer Collection	4-5
4.2.7	Disk Subsystem (NPC-800C)	4-5

4.2.8	Diskette Insertion	4-5
4.2.9	Diskette Removal	4-6
4.2.10	Adjustments	4-6
4.2.11	Operational Check of Disk Subsystem	4-6
4.3	SELF-TEST PROCEDURES	4-7
4.3.1	Introduction	4-7
4.3.2	Keyboard Test	4-7
4.3.3	Disk Test	4-8
4.3.4	RAM Test	4-9
4.3.5	Processor Self-Test	4-10
4.4	RETURNED MATERIAL AUTHORIZATION	4-11
4.4.1	Return of Equipment	4-11
4.4.2	Suggestions Concerning Return of Equipment	4-12
5	OPTION INSTALLATION	5-1
5.1	INTRODUCTION	5-1
6	GLOSSARY	6-1
7	APPLICATION NOTES	7-1
8	DEDICATED PROBES USER'S INSTRUCTIONS	8-1
	APPENDIX	A-1

LIST OF FIGURES AND TABLES

FIGURE		PAGE
Figure 1-1.	NPC-800 Series Electronic Workbench	1-1
Figure 1-2.	Basic NPC-800C Architecture	1-2
Figure 1-3.	NPC-800C Architecture With All Possible Internal Options	1-3
Figure 1-4.	Configuration Menu	1-4
Figure 1-5.	State Menu (Three of Sixteen Levels of Triggering are Shown)	1-5
Figure 1-6.	NPC-800C State Menu	1-6
Figure 1-7.	Clock Qualifier Field	1-7
Figure 1-8.	Trigger Qualifier Field	1-8
Figure 1-9.	NPC-800C Timing Menu	1-10
Figure 1-10.	Typical NPC-800 Timing Display at 20X Magnification	1-12
Figure 1-11.	Detachable, Folding Keyboard	1-14
Figure 1-12.	Standard Probes and Accessories	1-16
Figure 1-13.	Optional Model 87 Probe Set (Replaces Model 81)	1-17
Figure 1-14.	NPC-800C With Disk Drives Installed	1-18
Figure 1-15.	Typical NPC-800 Waveform Menu	1-20
Figure 1-16.	Typical Waveform Display	1-21
Figure 1-17.	Typical Counter-Timer Menu	1-22
Figure 1-18.	Measuring Interval Between Two State Events	1-23
Figure 1-19.	Event Histogram Bar Chart Display	1-24
Figure 1-20.	Time Interval Histogram Menu	1-25
Figure 1-21.	Simple One-Bit Signature Analyzer Menu	1-26
Figure 1-22.	Signature Analyzer Menu For Developing Software Signatures	1-27
Figure 1-23.	Model 70 Serial Transmit Menu	1-28
Figure 1-24.	The Model 70 Serial Probe	1-29
Figure 1-25.	Dedicated Probe for the 8086	1-30
Figure 1-26.	Typical Disassembly	1-31
Figure 1-27.	Simple Automated Test Program With Operator Prompts, Using Computer Option	1-33
Figure 1-28.	Typical CP/M Diskette Directory	1-34
Figure 1-29.	I/O Configuration Menu	1-36
Figure 2-1.	Programmable AC Voltage Selector	2-3
Figure 2-2.	CRT FRAME RATE SELECT Switch On Processor Board	2-5
Figure 2-3.	Probe Connections	2-6
Figure 2-4.	NPC-800C Rear Panel Connectors	2-7
Figure 3-1.	Configuration List	3-2
Figure 3-2.	Test Card Layout	3-4
Figure 3-3.	Configuration List	3-5
Figure 3-4.	HELP Prompt During State Menu Set-up	3-6
Figure 3-5.	NPC-800C's 48-Channel State Menu (Flashing prompting messages are not shown)	3-7
Figure 3-6.	State Menu with 0040 Selected as Trigger Word	3-10
Figure 3-7.	State Data Collection with 0040 as Trigger Word	3-11
Figure 3-8.	State Menu for Mixed Format Display	3-12
Figure 3-9.	First Difference Word Occurs at +700	3-14
Figure 3-10.	Word +704, First Word in Next Group of Data Words That are the "Same"	3-15
Figure 3-11.	Search Word Menu	3-16
Figure 3-12.	SEARCH WORD Menu with 009E as the Search Word	3-17
Figure 3-13.	Data Collection Showing 004E at Top of Display After Data Search is Completed	3-18

Figure 3-14.	State Menu Set for Pretrigger Data Collection	3-19
Figure 3-15.	Pretrigger Data	3-20
Figure 3-16.	Menu Used for Sequential Triggering	3-21
Figure 3-17.	Data Collection Corresponding to Sequential Triggering Example ..	3-22
Figure 3-18.	Using RESTART Feature to Ensure Program Path A-B-C-D is Followed	3-24
Figure 3-19.	State Menu with RESTART Word 0080	3-25
Figure 3-20.	Occurrence of 0080 (RESTART) Causes Trigger Stack to Reset to Level 0	3-26
Figure 3-21.	Setting Up Internal Clock Qualifier Field	3-28
Figure 3-22.	Qualified Data Collection Containing Addresses From 0040 Through 004F Only	3-29
Figure 3-23.	16-Channel Timing Menu	3-30
Figure 3-24.	Typical Timing Diagram Display	3-31
Figure 3-25.	Timing Diagram LABELS Function	3-32
Figure 3-26.	Magnified Data Display X20 (Locations 500 to 549)	3-35
Figure 3-27.	Timing Display with Expansion Symbol, E, At Location 500	3-36
Figure 3-28.	Measuring Relationship Between Timing Data Edges	3-37
Figure 3-29.	Menu showing NPC-800's Timing Display Flexibility	3-38
Figure 3-30.	NPC-800's Timing Diagram Display Flexibility	3-39
Figure 3-31.	Timing Diagram Assignment of Labels (NAMES)	3-40
Figure 3-32.	Menu Corresponding to This Example (Thus far)	3-41
Figure 3-33.	Timing Display At 1X Magnification	3-43
Figure 3-34.	A Correlation Factor of 1,000 Means That Data in a Main Memory Channel Precisely Matches Data in Corresponding Auxiliary Memory Channel	3-44
Figure 3-35.	MEMORY SELECT Key Used to Observe Effect of Short in Channel B5. (A) auxiliary memory. (B) main memory. Alternate between two by pressing X key.	3-45
Figure 3-36.	Position of Edge Qualification Field in Menu.	3-46
Figure 3-37.	Timing Diagram Showing Data Input From Test Card Channels A0-A7 and Input to Edge Qualifier Channel 33 on the A Probe (show as B0 above)	3-47
Figure 3-38.	Sample and Latch Mode Timing	3-49
Figure 3-39.	16-Channel State Display	3-50
Figure 3-40.	Linkage	3-51
Figure 3-41.	State menu for Linking State To Timing	3-52
Figure 3-42.	Timing Menu With Linkage Bit Set In ARM Linkage Field	3-53
Figure 3-43.	Linking State Analyzer's TRIGGER LEVEL 1 to Timing Analyzer	3-54
Figure 3-44.	Glitch Interspersed With Data	3-56
Figure 3-45.	Timing Display With Glitches	3-57
Figure 3-46.	Timing Diagram Using An External Clock	3-58
Figure 3-47.	High Speed Synchronous Data Displayed In State Format	3-59
Figure 3-48.	Frequency Mode With External As Source (Using Model 90 probe)	3-60
Figure 3-49.	Period Mode With External Source (Using State Probes; Total Mode is Similar)	3-61
Figure 3-50.	Interval Mode With State Data Probes As Source	3-62
Figure 3-51.	COUNTER-TIMER Menu	3-64
Figure 3-52.	Counter-Timer Display Indicating Frequency of Occurrence of Specified Data Word	3-65
Figure 3-53.	Counter-Timer Measurements of Interval Between START and STOP Data Words	3-66
Figure 3-54.	Frequency Measurement Using Counter-Timer	3-67

Figure 3-55.	Period Measurement Using Counter-Timer	3-68
Figure 3-56.	Use of Single Bit START and STOP Words	3-69
Figure 3-57.	Use of Single Bit START and STOP Words	3-71
Figure 3-58.	Display of Signature for Test Point DB0 of the B Channel	3-72
Figure 3-59.	New Signature For DB0 (B Counter)	3-73
Figure 3-60.	Waveform Menu	3-74
Figure 3-61.	Waveform Menu (See paragraph 3.10.5)	3-76
Figure 3-62.	Waveform Display at 1X Magnification	3-77
Figure 3-63.	Waveform Menu For Monitoring NPC-800C's Video Signal	3-79
Figure 3-64.	Timing Set-Up for Waveform (Example)	3-80
Figure 3-65.	Video Signal At 1X Magnification	3-81
Figure 3-66.	Examining Sync Pulse At X10 Magnification	3-82
Figure 3-67A.	Main Memory Displays	3-83
Figure 3-67B.	Auxiliary Memory Displays	3-84
Figure 3-68.	Aliasing High Frequency Waveform Displayed as a Low Frequency "Alias"	3-85
Figure 3-69.	Binary Values of Waveform Samples	3-86
Figure 3-70.	Waveform Menu	3-87
Figure 3-71.	Timing Menu	3-88
Figure 3-72.	State Menu	3-89
Figure 3-73.	State Data Collection	3-90
Figure 3-74.	Waveform Data Collection	3-91
Figure 3-75.	State Menu	3-92
Figure 3-76.	Timing Menu	3-93
Figure 3-77.	Timing Menu	3-94
Figure 3-78.	Waveform Menu	3-95
Figure 3-79.	Waveform Menu	3-96
Figure 3-80.	State Menu	3-97
Figure 3-81.	Timing Menu	3-98
Figure 3-82.	Secondary Configuration Menu	3-99
Figure 3-83.	Event Histogram Menu	3-100
Figure 3-84.	Event Histogram Display	3-101
Figure 3-85.	Time Interval Histogram Menu	3-102
Figure 3-86.	Time Interval Histogram Display	3-103
Figure 3-87.	Secondary Configuration Menu to Select Disassembly Software ...	3-104
Figure 3-88.	Disassembled Display of Arbitrary Test Card Data (Z80 Disassembler Used)	3-105
Figure 3-89.	Model 70 EDIT and TRANSMIT Menu	3-106
Figure 3-90.	Response To Request For Space Status On Disk	3-115
Figure 3-91.	Using "STAT" Command To Determine Size Of File	3-116
Figure 3-92.	FORMAT 2, Used To Format New NPC-800C Disk	3-119
Figure 3-93.	Sample Source File Created By ED	3-120
Figure 3-94.	Sample .PRN File Created By ASM	3-121
Figure 3-95.	Sample .HEX File Created By ASM	3-122
Figure 3-96.	Example of SUBMIT Utility	3-123
Figure 3-97.	PAUSE Program	3-126
Figure 3-98.	AUTOTEST Program	3-127
Figure 3-99.	I/O Menu	3-132
Figure 3-100.	I/O Menu For Transmitting Timing Menu To An NPC-800 (acting as DEVICE on GPIB bus)	3-166
Figure 3-101.	I/O Menu For Receiving Timing Menu from another NPC-800C ...	3-167
Figure 3-102.	Main Menu	3-168
Figure 3-103.	Logic Analyzer Command Menu	3-169

Figure 3-104.	Setting Up State Format Field	3-170
Figure 3-105.	State Menu Set-Up	3-171
Figure 3-106.	Corresponding State Display	3-172
Figure 3-107.	Dip Switch Location On Processor Board	3-174
Figure 3-108.	Processor Board DIP Switch Settings	3-175
Figure 3-109.	I/O Menu	3-177
Figure 3-110.	I/O Configuration Menu, Used To Transmit Keystrokes to Another Device Such as a Terminal	3-181
Figure 4-1.	Processor Self-Test	4-2
Figure 4-2.	Arbitrary State Data Collection For NPC-800C	4-3
Figure 4-3.	Arbitrary Timing Data Collection	4-4
Figure 4-4.	Waveform Display Without Input Signal	4-5
Figure 4-5.	Loading Diskette	4-6
Figure 4-6.	KYBDTEST	4-8
Figure 4-7.	DSK5TEST	4-9
Figure 4-8.	RAMTEST	4-10
Figure 4-9.	Processor Self-Test	4-11

TABLE

Table 1-1.	The Nicolet 800 Series Configuration Guide	1-38
Table 3-1.	Power Up/Reset I/O Initialization	3-133
Table 3-2.	Command Formats and Field Definitions	3-159
Table 3-3.	NPC-800C Command List (Other than Keyboard Commands)	3-160
Table 3-4.	Command Formats	3-161
Table 3-5.	Baud Rate Select	3-178
Table 3-6.	Command Formats and Field Definitions	3-182
Table 3-7.	NPC-800C Command List (Other than Keyboard Commands)	3-183
Table 3-8.	Command Formats	3-184

Section 1

GENERAL INFORMATION

1.1 INTRODUCTION

This manual provides all the information required to understand, operate and troubleshoot the NPC-800C, one of five logic analyzers in the NPC-800 Series Logic Analysis System. These instruments have been designed to provide the digital engineer or technician with all the tools necessary to solve software or hardware problems. Each analyzer in the NPC-800 Series contains a different set of basic logic analysis capabilities and allows a number of useful options to be added to augment the basic system capabilities, (see Figure 1-1).

	STATE ANALYZER	TIMING ANALYZER	SERIAL	WAVEFORM
INPUTS	NPC-800A—32 Data, 2 Clock, 6 Qual NPC-800B—48 Data, 3 Clock, 8 Qual NPC-800C—48 Data, 3 Clock, 8 Qual NPC-800D—48 Data, 3 Clock, 6 Qual NPC-800E	16 Data, Clock Qualifier	8 Data, 8 Control 8 Data, 8 Control 8 Data, 8 Control 8 Data, 8 Control	Single Channel 10µV/Division to 20V/Division
Maximum Data Rates	NPC-800A 20 MHz NPC-800B 20 MHz NPC-800C 20 MHz NPC-800D 25 MHz NPC-800E	100 MHz, 8 Channels 100 MHz, 8 Channels 200 MHz, 16 Channels 200 MHz, 16 Channels 200 MHz, 16 Channels	19.2K Baud Receive/Transmit	50 MHz 6 Bit A/D
Maximum Real-Time Memory Depth	1000 Words	2000 Words	1000 Characters	1000 Samples
Maximum Auxiliary Memory Depth	1000 Words	2000 Words	1000 Characters	1000 Samples
Trigger Levels (Steps)	NPC-800A 16 NPC-800B 16 NPC-800C 16 NPC-800D 8 NPC-800E	2 2 3 3 3	16	0%-100% Positive/Negative Slope
Delays	After N Clocks, Not on N Clocks, Before N Clocks, On N Clocks, Occurs N Times: 0 ≤ N ≤ 9,999			Uses Timing Analyzer Triggering/Delay Circuit
Maximum Pretrigger	999 Words	1800 Words	999 Characters	900 Samples
Display	Hex, Oct, Decimal Binary, ASCII — In Any Mix	16 Timing: Hex, Oct, Decimal, Binary, ASCII	Characters-ASCII; Control — Binary, Hex etc.	Analog Waveform (Software Smoothed or Unsmoothed)
Internal Linkages	State-To-Timing Waveform	Timing-To-State, Serial, Waveform	Serial-To-Timing, Waveform	Waveform-To-Timing Serial, State

Counter/Timer		Signature Analyzer	
Modes	Freq., Period, Total, Interval	Formats	STD, and Hex
Max. Input Freq.	100 MHz	Input	Scope Probe (1x/10x)
Input Sources	Scope Probe (1x/10x) or State Analyzer Word Recognizers	Gate	State Analyzer Word Recognizers

I/O and Computing Facilities		
IEEE-488	Device	Controller
RS-232	Slave	Master
CP/M	T & M Processing	General Purpose Computer
Histogram Facilities	Event	Time Interval

Figure 1-1. NPC-800 Series Electronic Workbench

Detailed specifications for the NPC-800C are found in Section 1.5.

1.2 SYSTEM DESCRIPTION

The NPC-800C consists of a 48-channel state analyzer and a 16-bit channel timing analyzer. Featuring a 9-inch CRT and a standard ASCII keyboard, (see Figure 1-2) it has provisions for internal and external options, (see Figure 1-3). The logic analyzer operating software has 48k bytes of ROM.



Figure 1-2. Basic NPC-800C Architecture

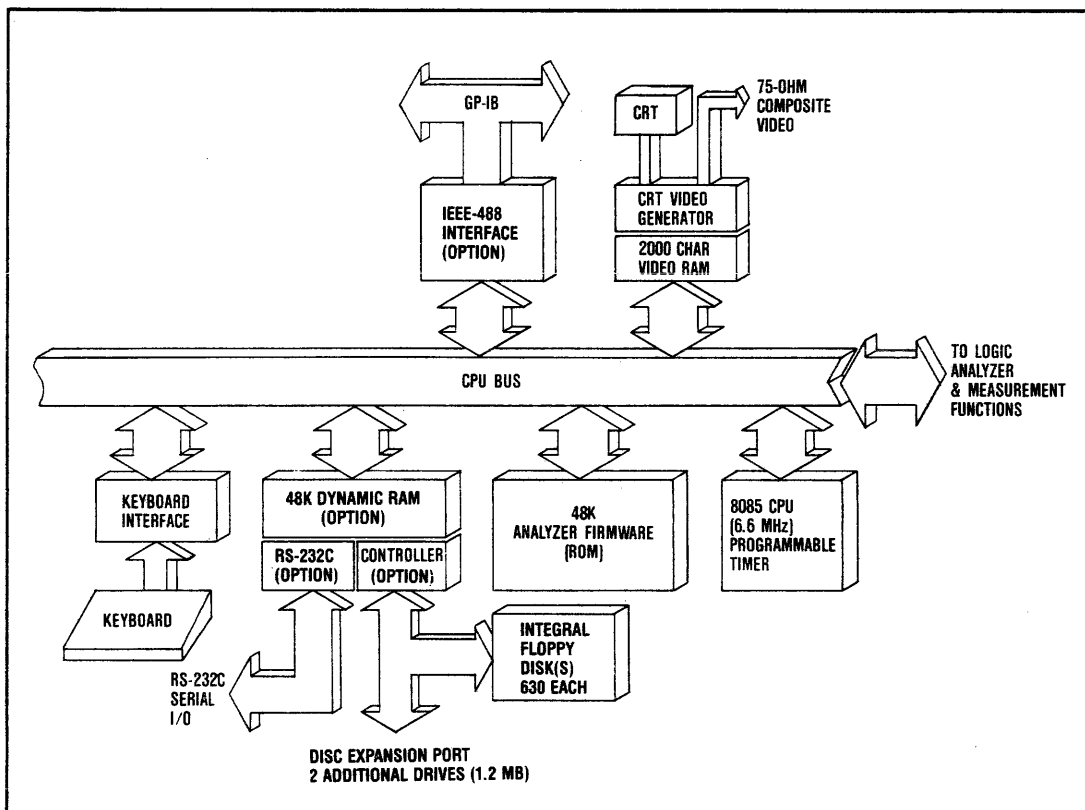

Figure 1-3. NPC-800C Architecture With All Possible Internal Options

1.2.1 Easy Operation

From start-up, all NPC-800 series instruments are easy-to-operate. Menus are organized in a natural and comfortable manner that take you quickly and simply through the desired test. Prompting messages, soft keys and labels minimize the need to refer to this manual.

Because all menus default to the most commonly used parameters, simple problem-solving and meaningful data collections can be performed without any special set-ups. For example, when monitoring a microprocessor operation, a single keystroke on the NPC-800 allows you to see if your ADDRESS, DATA and STATUS signals are functioning properly.

1.2.2 Rapid Set-Up

When power is applied to an NPC-800 series instrument, a Configuration List, (see Figure 1-4), containing all available test and measurement modes, appears on a 9-inch, 80-character by 25-line CRT display. At the bottom of the display are labels for six software-directed (or "soft") keys which allow you to select the mode best suited to your current application. The function of each "soft" key changes each time the display changes, but the current function of each "soft" key is always shown at the bottom of the screen.

```
NR  NICOLET PARATRONICS 800C CONFIGURATION  VER 3 REV A

  1 - 48 CHNL STATE
  2 - 16 CHNL TIMING
  3 - 48 CHNL STATE/16 CHNL TIMING
  4 - 8 CHNL TIMING GLITCH
  5 - 48 CHNL STATE/8 CHNL GLITCH
  6 - WAVEFORM RECORDER
  7 - 48 CHNL STATE/WAVEFORM
  8 - COUNTER/TIMER
  9 - SIGNATURE ANALYZER
 10 - PI 70 SERIAL PROBE TRANSMIT

ESC - DISK OPERATING SYSTEM

BREAK - PROCESSOR SELF-TEST

I - I/O CONFIGURATION MENU

F1      F2      F3      F4      F5      F6
STATE   STATE   STATE   SEL DOWN SEL UP   COLLECT
```

Figure 1-4. Configuration Menu

Once the desired mode is selected, the corresponding menu is displayed with its own set of soft-key labels. The soft keys allow you to access the menu fields so you can "enter in" test parameters from the ASCII keyboard. If an entry error occurs, a message appears on the CRT telling you which keys are valid for the current menu operation.

```

48 CHANNEL STATE MENU

FORMAT: ██████████ ██████████ ██████████ ██████████ ██████████ ██████████
        A ██████████
CLK SEL: A PRB: █ B PRB: █ C PRB: █ QUALIFIERS FORMAT: -AABBCC EL
CLK QUAL: ██████████
OR ██████████
PRE-TRIG MEMORY (0-999): ██████████ WORDS
RESTART: ██████████
TRIGGER:
0      0040XXXXXXXX -XXXXXX XX
1 THEN 0042XXXXXXXX -XXXXXX XX
2 THEN 0065XXXXXXXX -XXXXXX XX
█████████

                                AFTER 1000 CLOCKS
                                OCCURS 0003 TIMES

                                H - HEX
                                O - OCTAL
                                Z - DEC
                                N - BINARY
                                Y - ASCII
                                U - USER

S1 - DATA DISPLAY
F1    F2    F3    F4    F5    F6
PREVIOUS  NEXT  SELECT  DEFAULT  CONFIG  COLLECT

```

Figure 1-5. State Menu (Three of Sixteen Levels of Triggering are Shown)

Menu fields controlling advanced triggering modes can be turned off at any time, reducing your triggering set-up to a simpler form. In this manner, you can check that basic triggering conditions can be satisfied before activating the advanced set-up. This illustrates the time-saving, “start simple and build” philosophy behind the NPC-800 series. Advanced features do not obstruct simple problem-solving. They are available and readily accessible when you need them.

1.2.3 Logic State Analyzer

Readily accessed through the ASCII keyboard, each NPC-800 series analyzer incorporates a logic state section featuring some of the most powerful software debugging features available in the industry. Upon initial selection, the state menu defaults to the most commonly-used parameters so you can collect meaningful data immediately.

When more debugging power is needed, you can “build” on the basic state menu by calling up additional triggering levels, qualifiers, and other features. Operator prompts minimize your set-up time. A typical NPC-800C state menu is shown in Figure 1- 6.

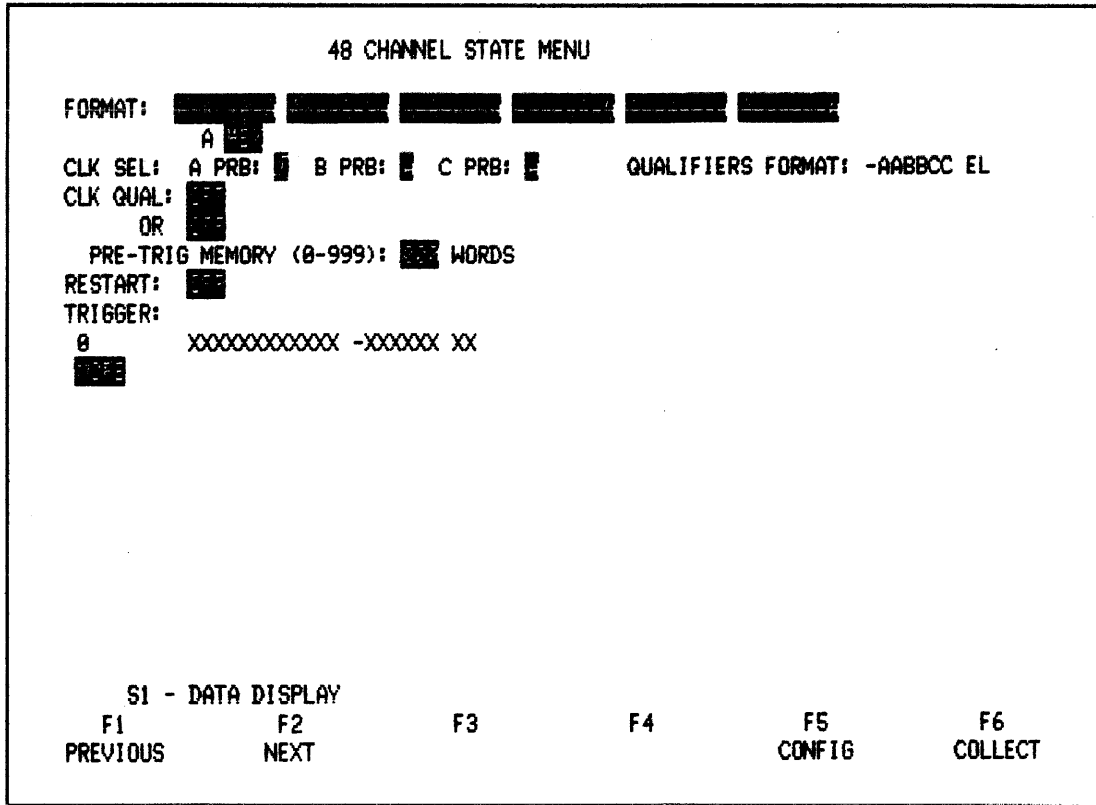

Figure 1-6. NPC-800C State Menu

1.2.3.1 Software Analysis

The state analyzer section for the NPC-800C is summarized below:

State Channels	Clock Qualifiers	Number of Clock Inputs	Main Memory Depth	Auxiliary Memory Depth	Trigger Levels	Pretrig-gering
48	Dual 55-Bit Wide	3	1000 Words	1000 Words	16	0-999 Words

The state analyzer allows you to collect ADDRESS, DATA, STATUS, or other synchronous occurrences from the digital portion of your system, at real-time rates up to 15 million events per second. And each instrument features menu-controlled linkage to internal or external test and measurement functions.

1.2.3.2 Collection Clock Qualified Data

NPC-800's Clock Qualification mode extends trace capabilities of each state analyzer's 1000-word memory by restricting the data collection to specific events of interest. The clock qualification field in the state menu is partitioned into two sections: an internal clock qualifier field and an external field (see Figure 1-7).

```

          48 CHANNEL STATE MENU

FORMAT:  [REDACTED] [REDACTED] [REDACTED] [REDACTED] [REDACTED] [REDACTED]
          A [REDACTED]
CLK SEL: A PRB: [REDACTED] B PRB: [REDACTED] C PRB: [REDACTED]   QUALIFIERS FORMAT: -AABBCC EL
CLK QUAL: XXXXXXXX XXXXXXXX XXXXXXXX XXXXXXXX XXXXXXXX XXXXXXXX -XXXXXX X
          OR [REDACTED]
PRE-TRIG MEMORY (0-999): [REDACTED] WORDS
RESTART: [REDACTED]
TRIGGER:
0         XXXXXXXXXXXX -XXXXXX XX
[REDACTED]

                                     H - HEX
                                     O - OCTAL
                                     Z - DEC
                                     N - BINARY
                                     Y - ASCII
                                     U - USER

          S1 - DATA DISPLAY
          F1      F2      F3      F4      F5      F6
PREVIOUS  NEXT    SELECT  DEFAULT  CONFIG  COLLECT
    
```

Figure 1-7. Clock Qualifier Field

The internal field is used to “self-qualify” data coming into the analyzer from the probes. If a match occurs between the pattern set into the internal field and an incoming data word, then that data word is clocked into memory. Since the internal clock qualifier field can be as wide as the maximum number of channels of the state analyzer, one application of this function is to collect data over a certain range of addresses or data words. This is accomplished by specifying, in the internal field, only the most significant address or data bits and leaving the remaining bits unspecified (don’t care).

To control the data collection, the external clock qualifier field uses separate lines (two per 16-channel state probe plus one BNC input at the rear of the analyzer). To clock data into the memory, if one or more of the bits in the external field are set, signals on corresponding probe qualifier lines must match. A typical application uses microprocessor status signals to restrict data collection to memory, I/O or other operations of interest.

Clock qualifier fields for each NPC-800C state analyzer are partitioned as follows:

Internal Field	External Field		Total State Clock Qualifier Field
Data Probe Inputs	Data Probe Qualifiers	EXT BNC Connector	
48	6	1	55

1.2.3.3 Multiphase Clocking

Multiphase clocking allows data from the 16-channel state probes to be strobed into the analyzer at different times but displayed as if all incoming data were present simultaneously. For example, to simplify program tracing, an ADDRESS/DATA bus can be demultiplexed so that address and corresponding data words are displayed side-by-side.

1.2.3.4 Triggering

For branch and subroutine analysis, all NPC-800C state analyzers offer multilevel triggering with auto or manual restart capabilities. Using the state menu, you can build up to 16 levels of sequential triggering to trace deeply-nested sections of your code. Like the clock qualifier function, the NPC-800's state triggering levels are each divided into an internal field and an external field, (see Figure 1-8).

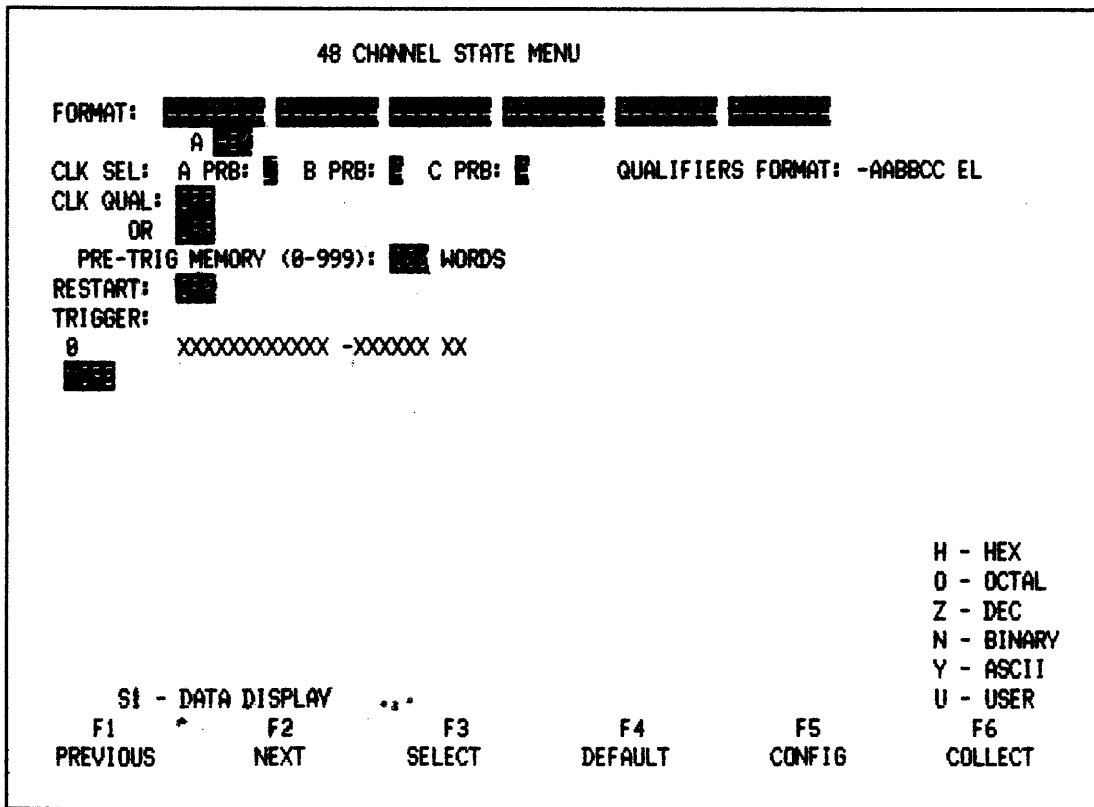

Figure 1-8. Trigger Qualifier Field

For triggering to occur, incoming data from the probes must match the pattern specified in the internal field at each trigger level. The trigger fields for each NPC-800 state analyzer are partitioned as follows:

Internal Field	External Field			Total State Trigger Field
Data Probe Inputs	Data Probe Qualifiers	EXT BNC Connector	Linkage Bit	
48	6	1	1	56

The external trigger qualifier field uses the same probe and rear panel BNC control lines as the external clock qualifier field, plus one linkage bit. Connecting the microprocessor's branch status signal to a trigger qualifier line to enable triggering only when a jump instruction is executed is a typical application. Using the linkage bit to trigger the state analyzer when commanded by the timing analyzer, the waveform analyzer, or any other test instrument (including another NPC logic analyzer model) is another typical and powerful application.

Further, at each trigger level, you can specify the time relationship of the current trigger word to the prior trigger word. For example, you can specify that the trigger word at the current level occur precisely *n* clocks after the word on the prior level. Other ways to characterize this time relationship include: after *n* clocks, before *n* clocks, not on *n* clocks. You can also specify that the current trigger word occur *n* times before the state analyzer advances to the next level.

Each NPC-800C state analyzer also incorporates an AUTO-RESTART feature which automatically resets the analyzer back to the first trigger level if a user-specified triggering sequence is not completely satisfied. This situation can occur, for example, when an unexpected branch occurs during the sequence, so that subsequent triggering conditions cannot be satisfied. There is also a user-controlled RESTART function which allows you to specify a pattern in the state menu that resets the analyzer's trigger stack when that pattern occurs in the incoming data.

In all, each NPC-800C state analyzer offers approximately 150 state triggering combinations which can handle virtually any software debugging requirement you're likely to encounter.

For additional time-savings, all NPC-800C state analyzers display test codes that provide a quick, short-hand method of uniquely identifying your data collection. For each block of collected data, 16 bits wide by 1000 words deep, a 4-digit hexadecimal test code is computed by the analyzer using a data compression algorithm. Thus, two data collections can be quickly compared by simply comparing the "test code".

To further save time, you can put your NPC-800 to work overnight to detect and isolate hard-to-find, intermittent failures. Using the state auxiliary memory and a special triggering mode called HOLD /, you can compare a known good reference collection to unknown, incoming data. If the two collections match, the test is automatically repeated. If a difference is detected, the NPC-800 displays the faulty collection with all differences highlighted, ready for inspection when you arrive at work the next morning.

1.2.3.5 State Analysis—Only One Part Of The Electronic Workbench

The state analyzer's debugging power is further enhanced when used with other test and measurement functions. For example, the state analyzer can be linked to the timing analyzer and analog waveform recorder for cross-domain analysis; with the counter-timer/signature analyzer for system performance measurements; with the serial analyzer for debugging RS-232 interfaces; and with other external instruments as part of a completely automatic test system.

1.2.3.6 Additional Time-Saving Features

To further save analysis time, data can be specified in the state menu for display in any combination of hexadecimal, octal, decimal, binary, or ASCII characters. Displayed information can be grouped into as many as six different fields, with each field one or more bits wide. You can also blank one or more bits anywhere in the data field. Using optional disassembly software, microprocessor ADDRESS, DATA, and STATUS words are disassembled into an easy-to-read, mnemonic format.

1.2.4 Independent Timing Analyzer

For hardware debugging, each NPC-800C analyzer incorporates an independent timing analyzer with advanced triggering, data collection, and display capabilities. Like the state analyzer section, these capabilities, when initially selected, default to the most commonly used parameters so you can collect meaningful data with a minimum of keystrokes. For more in-depth hardware analysis, simple ASCII keyboard commands, which are coupled with operator prompts, reduce the time needed in setting up complex tests. A typical NPC-800C timing menu is shown in Figure 1-9.

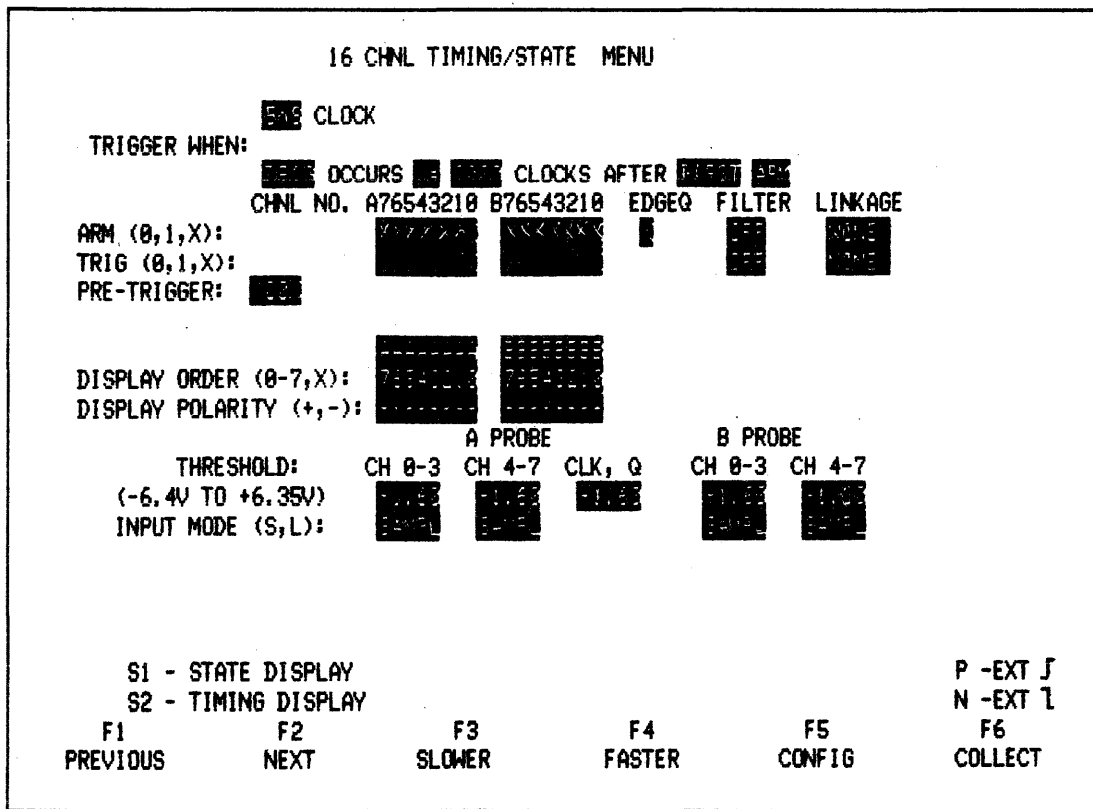

Figure 1-9. NPC-800C Timing Menu

1.2.4.1 Powerful Hardware Analysis

The timing analyzer section for the NPC-800C is summarized below.

Timing Channels	Max Sampling Rate	Main Memory Depth	Auxiliary Memory Depth	Glitch Capture	External Clock Input	External Clock Qualifier
16	16 ch; @ 200 MHZ	16 ch; @ 1000 words	16 ch; @ 1000 words	YES	1	1

Like the state section, the NPC-800's timing analyzer can be linked to other internal or external test and measurement functions to trace hardware and software interactions in your system.

1.2.4.2 Advanced Triggering

The optimum number of triggering levels for a timing analyzer is two because only one level makes relatively routine timing measurements difficult. More than two levels implies branch and subroutine tracing applications which are best performed by the state analyzer.

For this reason, NPC-800's timing analyzer includes two levels of word recognition: ARM and TRIG. A significant advantage is that the analyzer **trigger events are processed at up to 200 MHz, 16-channels wide.**

When you use both trigger levels, three conditions must be satisfied before the timing analyzer will collect data:

1. the ARM event must occur,
2. the specified delay between ARM and TRIG must be satisfied, and
3. the TRIG event must occur.

Because of the large number of interactive signals in today's digital systems, it is necessary for a timing analyzer to provide the user flexibility in specifying the time relationship between the ARM and TRIG events. The NPC-800's timing analyzer accomplishes this through the following powerful delay modes:

- TRIG occurs GREATER THAN nnnn clocks AFTER FIRST ARM
- TRIG occurs AFTER nnnn ARMS

In the above modes, GREATER THAN can be changed to LESS THAN or ON; AFTER can be changed to BEFORE; FIRST can be LAST; ARM can be substituted for ARM; and TRIG for TRIG. The bar symbol over the ARM and TRIG words identifies the nonoccurrence triggering mode.

Thus, for example, if an expected TRIG event was not occurring exactly nnnn clocks after the ARM event had ended, you would simply use the following triggering mode to see what was really happening:

TRIG occurs ON nnnn clocks AFTER LAST ARM

In all, there are approximately 50 timing triggering combinations which can satisfy virtually any hardware debugging requirement.

If your problem is broader in nature, involving hardware-software or even digital-analog interactions, you can readily link the triggering of the timing analyzer to various combinations of state, waveform, or other, external measurement resources. For example, by linking the timing and state sections, you can observe and measure the performance of both the hardware interrupts and the associated software routines.

1.2.4.3 Complex Timing Measurements Made Easy

Because timing information is generally more difficult to analyze than state or analog information, a good timing analyzer should have extensive, yet easy-to-use, display manipulation capabilities. The display facilities of the NPC-800's timing analyzer have evolved through four generations of analysis instruments and provide one of the most useable presentations of timing information on the market.

For instance, when timing information is displayed, a moveable, inverse video graticule gives you an overview of the position and amount of data being displayed relative to the entire contents of the timing memory, (see Figure 1-10).

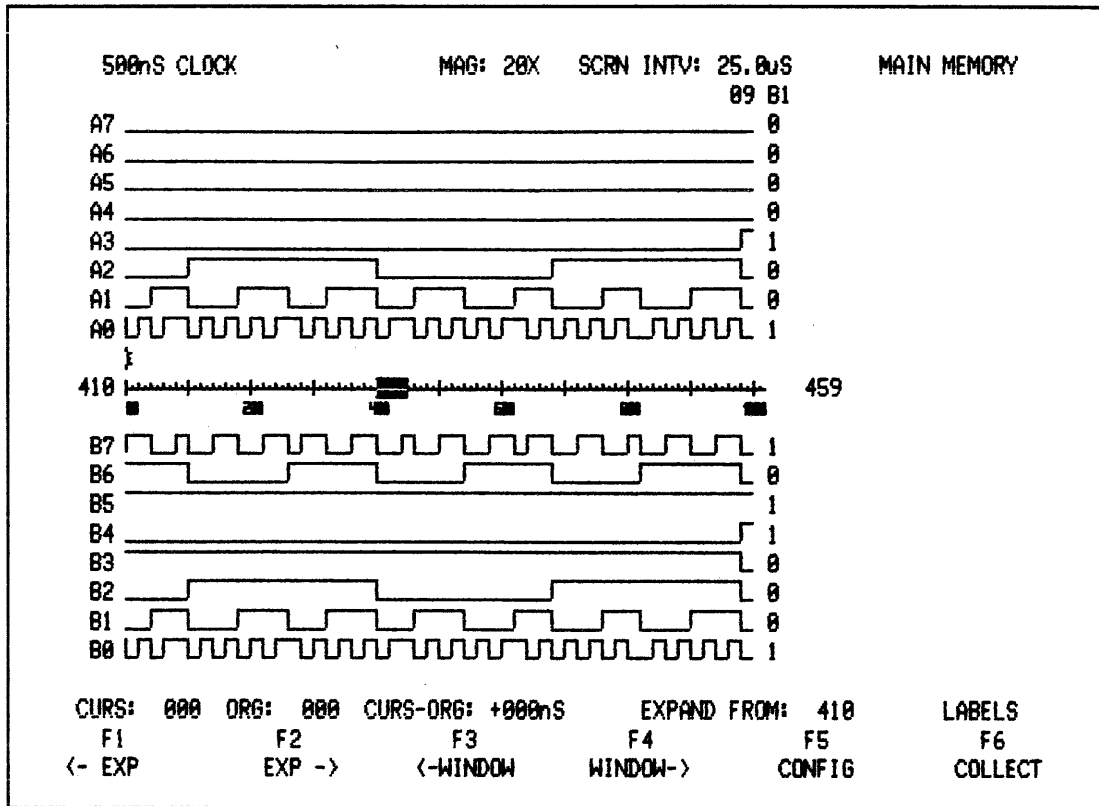

Figure 1-10. Typical NPC-800 Timing Display at 20X Magnification

Furthermore, all important timing parameters—sample rate, magnification factor (up to X20), screen interval, and cursor locations and origin—are all shown with displayed data so you don't have to go back to the parameters in the menu to make sense of your timing measurements.

To make the display more meaningful, you can name each channel with the 8-character label of your choice.

If you need to rearrange the display order and polarity you don't have to adjust the probes; simply make the necessary changes in the timing menu. Probe input comparator thresholds are also ASCII-keyboard selectable. A single keystroke gives you a state-equivalent display which can then be formatted in hexadecimal, octal, binary, decimal or ASCII.

1.2.4.4 Comparison Testing

Like the state analyzer, the timing section has a separate, matching, auxiliary memory for comparing current data collection with a known good reference. There is also a CORRELATION mode which tells you (mathematically on a channel-by-channel basis) how closely main and auxiliary data collections match.

For example, if pulses are intermittently missing in a hardware sequencer, data in the main and auxiliary memories differ. Thus, the correlation factor for that particular channel will be low. A single keystroke selects a main/auxiliary memory comparison mode to automatically highlight those missing pulses.

If you'd like to have a permanent record of this and any other tests, and the associated menu, simply save them on the optional diskette.

1.2.4.5 High Speed Collecting

For high-speed work, you can select the 200 MHz internal clock speed. The NPC-800C actually processes the ARM and TRIG events at up to 200 MHz. Thus, you can trigger and collect 1000 samples at five nanosecond intervals, increasing the probability of capturing and viewing those high-speed problems.

1.2.4.6 Timing Memory Reconfiguration

Another mode, the 8-CHANNEL GLITCH, partitions 16-channel timing memory into an 8-channel glitch memory and a corresponding 8-channel data memory. This mode is used to display glitches as they occur in relationship to actual data, superimposing the glitch data onto the timing data.

1.2.4.7 Keyboard

One of the most time-saving features of the NPC-800C is its standard ASCII keyboard, (see Figure 1-11). This keyboard allows the operator to send data to the computer and to make data entries or menu changes in the logic analyzer and other analysis sections of the instrument. Most keys are the same as they are on an ordinary terminal or typewriter; that is, they type the same alphanumeric characters. This familiar arrangement permits faster programming and menu set-ups without learning dedicated keys.

For their mutual protection during transport, the keyboard assembly folds up conveniently over the CRT and optional disk drives.



Figure 1-11. Detachable, Folding Keyboard

When you turn on the NPC-800C, allow 5 to 30 seconds for the CRT to warm up. The NPC-800C is in the Analyzer mode upon power up. The initial display is a list of analysis functions. To use the keyboard for computer operations, escape Analyzer mode by pressing ESC key. Then load a CP/M diskette as described in Section 2.3.3. After the CP/M version number appears, you should then see a line and a blinking reverse video block cursor in the upper left-hand corner (the home position) of the screen.

The cursor identifies where the next character can be written. The screen contains 2000 normal character positions or 25 lines of 80 characters each. Only one character can occupy a character position at any given time and will remain there until it is erased or replaced. Upon pressing ESC key, the processor clears the screen by placing spaces in all character positions.

The keyboard consists of single-pole/single-throw switches in a matrix which are scanned by keyboard-encoding hardware located in the keyboard. The hardware is periodically polled by the software.

1.2.4.8 Alphabetic Keys

The keyboard incorporates the standard 26 letters of the alphabet (in lower-case or upper-case as determined by the SHIFT key). Use the CAPS LOCK key to obtain upper-case letters only.

1.2.4.9 Nonalphabetic Keys

Nonalphabetic keys are those with double markings. These include the numbers 0 through 9, punctuation marks, and special characters. The lower marking is generated when the SHIFT key is released, while the upper marking is generated with the SHIFT key down. The CAPS LOCK key will not shift these keys.

1.2.4.10 Nondisplayable Keys

In addition to the standard typewriter keys, the following eleven function keys are included in the keyboard:

RETURN — Moves cursor to first character position. If cursor is already at first character position, it remains there. RETURN is also called “carriage return” (CR). An automatic line feed is included in the RETURN function.

LINE FEED — Moves cursor down one line. If cursor is at bottom line, a LINE FEED causes it to remain there, but all data on screen moves up one line. Data on top line are lost as they are scrolled up and off screen.

SPACE BAR — Causes cursor to move one character position to the right. If you depress SPACE BAR when cursor is at right end of a line, cursor remains there since neither a carriage return nor a line feed is generated.

BACK SPACE — Moves cursor one space to left. If cursor is at start (left end) of a line, it will not move when BACK SPACE key is depressed.

DELETE — Causes last character entered to be cancelled.

TAB — Moves cursor to next tab stop (eight character spaces) to the right. Using columns numbered from 1 through 80, tab stops are fixed at 9, 17, 25, 33, 41, 49, 57, 65, and 73. If cursor is at a character position 73 through 79, it only moves one character position to the right each time the TAB key is depressed. If cursor is at character position 80, it will not move.

ESC (Escape) — In a general sense, causes software to enter and exit special modes. Normally this key is only used when the computer option is installed.

REPEAT — When this key is held down, with another key, it repeats the function of the other key as long as both keys are held down. The repeat rate is approximately five-characters per second.

BREAK — When this key is selected, it generates a continuous space and is generally used to tell the computer that you wish to interrupt program execution. With the Configuration List displayed, break key initiates PROCESSOR SELF-TEST.

S1, S2 — These two keys are special keys that function according to prompts in the logic analyzer menus.

CTRL — To send control codes to the processor, hold down this key while one of the other keys is depressed.

1.2.4.11 Special Keys (F1-F6, LABELS, RESET)

F1-F6 — There are six software-directed (“soft”) keys below the CRT that are automatically labeled on the screen by software.

LABELS — Depressing LABELS key causes a prompting message to appear on right-hand side of CRT. Prompting message is dependent on analysis mode. It lists keys that can be selected to alter menus, change display formats, and save or recall data.

RESET — The red RESET key returns the NPC-800C to an initial power-on condition:

processor RAM is cleared and the CONFIGURATION LIST appears on the CRT. A beep indicates completion of RESET.

To avoid causing an accidental RESET, this key must be held down for approximately two seconds.

NOTE

RESET erases all menu parameters and auxiliary memory data.

1.3 ACCESSORIES SUPPLIED

1.3.1 General Purpose Probes

To simplify interconnections, each NPC-800C is supplied with a complete set of probes and terminators. Three probe types are available: the Model 51A, the Model 81 and the Model 87. Each Model 51A accommodates 16 state channels, two qualifiers and an external clock. Each Model 81 probe accommodates 8 timing channels, 1 qualifier and a clock. The Model 87, which is actually a set of 5 dual-channel probes, is offered as an alternative to the Model 81. Whereas the Model 81 is perfectly suitable for monitoring signals that are physically in the same general area of your system, the Model 87 is ideal for the analysis of large systems where monitoring points can be as far as eight feet apart, (see Figures 1-12 and 1-13).

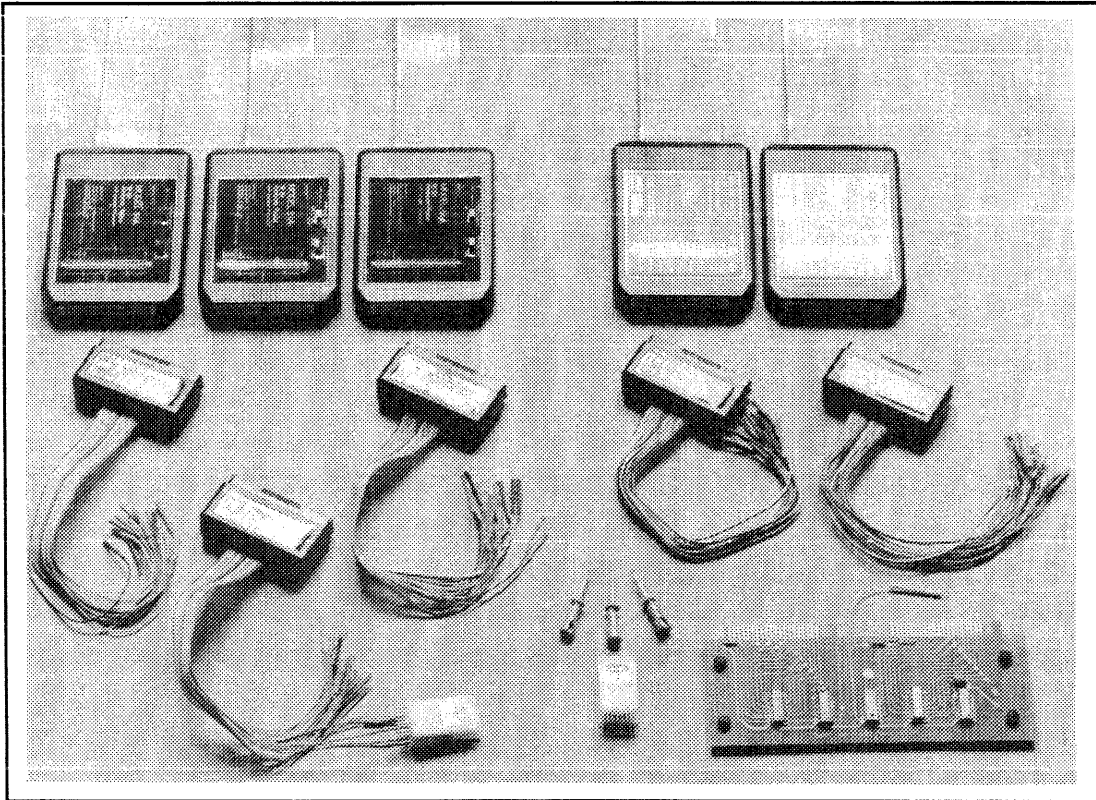

Figure 1-12. Standard Probes and Accessories

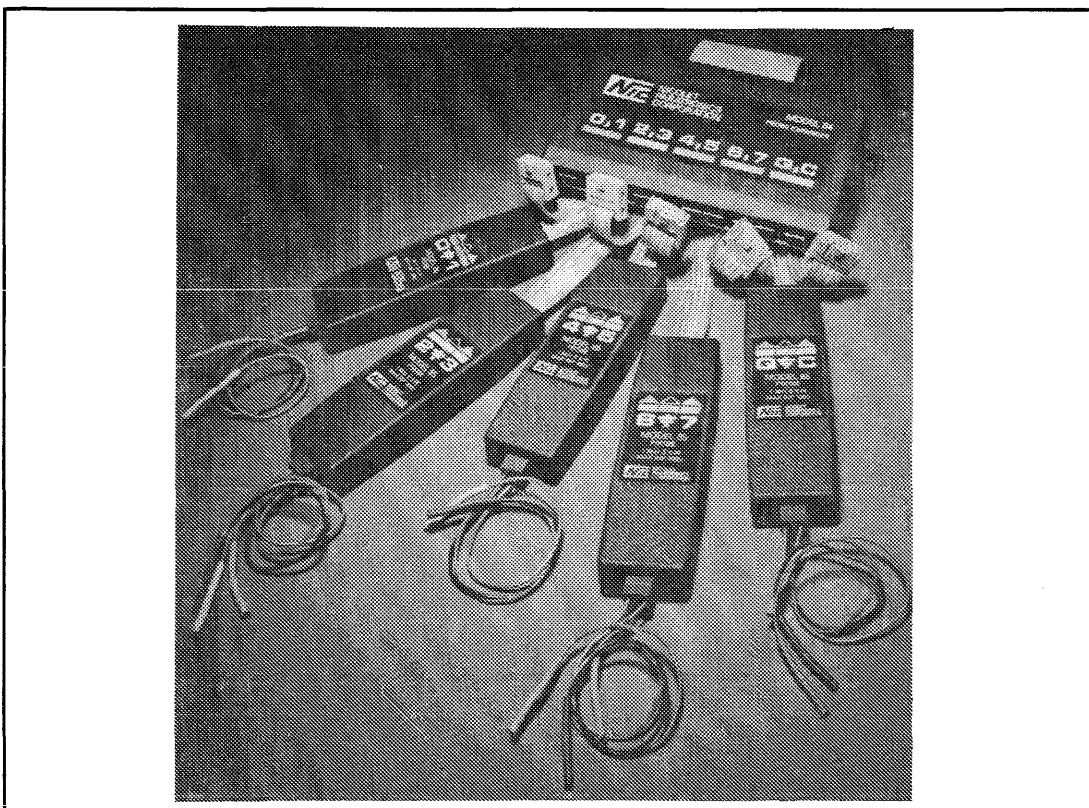

Figure 1-13. Optional Model 87 Probe Set (Replaces Model 81)

When optional test and measurement functions are installed, such as waveform or counter timer/signature analyzers, a Model 90 X1/X10 probe is provided.

For all probes, compatible terminators are included which are color-coded and labeled for easy identification. State and timing probe terminators interface with IC clips, wire-wrap pins, and spring-loaded miniature grabbers.

1.3.2 Basic Equipment

The following items form the basis of every shipment:

1. NPC-800C Logic Analysis System
2. Probes

Each state and timing analyzer has the following probes as standard:

- **State Analyzer:** Three Model 51A state probes, (16-channel variable threshold).
- **Timing Analyzer:** Two Model 81A timing/state probes (8-channel variable threshold timing).

3. Probe Terminators

For connection to the system-under-test. The following probe terminators are standard:

- **Model 52-1:** One provided with each Model 51A probe.
- **Model 82-1:** One provided with each Model 81A probe.
- **Model 83-1:** One provided with each Model 81A probe.

NOTE

A package of 30 "ball clips" is included with the terminators.

4. Miscellaneous Items

- Accessory case
- 3-wire line cord
- Logic analyzer test card
- Operator's manual

1.4 OPTIONS DESCRIPTIONS

1.4.1 Nonvolatile Memory

To further reduce test time, one or two integral 5½-inch floppy disk drives can be installed in the NPC-800C. Simple commands allow you to store menu set-ups and test results. Later, these tests can be recalled and executed. A blank diskette can accommodate approximately fifty individual tests.

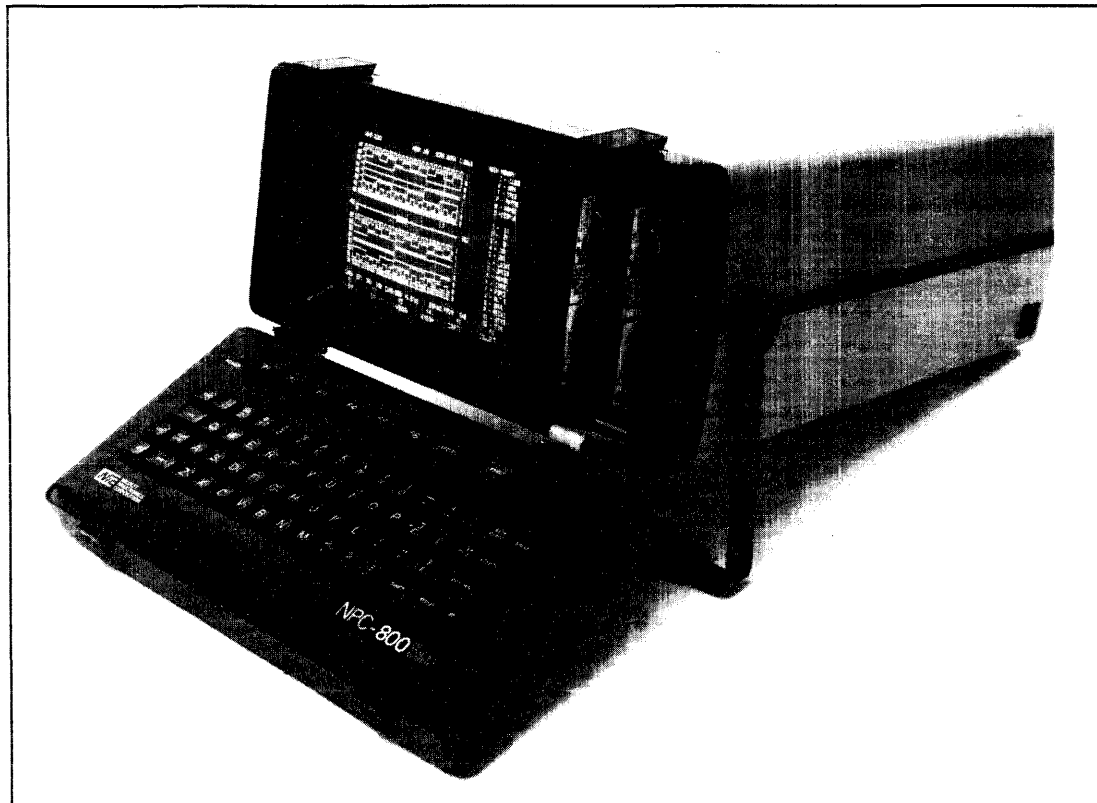

Figure 1-14. NPC-800C With Disk Drives Installed

1.4.2 Diskette

The NPC-800C uses a 5½-inch, double-sided, double-density flexible disk drive. When buying additional diskettes, specify certified double-density, two-sided operation diskettes. Nicolet Paratronics' P/N 112-0503-0002 is Dysan's model 204/2D, PN802067 soft-sector, double-sided, double-density, 96/100 tracks or an equivalent.

Each of the two integral floppy disk drives use a 5½-inch, double-sided, double-density, soft-sectored, 96 TPI diskettes, with 660k bytes of formatted capacity. There is a connector at the rear of the NPC-800C which, using an external, dual-drive expansion chassis, allows you to expand the disk memory system.

1.4.3 Waveform Analyzer

Though there are many digital systems, you still have to find problems caused by analog signals. That's why NPC offers a plug-in, waveform analyzer option for the NPC-800 series.

The waveform analyzer plug-in, which provides cost-effective, high-speed, analog waveform recording, can be used to uncover problems resulting from analog and digital interactions in your system. Using a 6-bit, a/d converter, analog signals are sampled at rates to 50 MHz, providing an effective 3 dB bandwidth of 10 MHz.

Each time a data collection is initiated, 1000 samples are stored. Displayed sample points are software-smoothed for readability.

1.4.4 Powerful Analog Analysis

The waveform analyzer section is summarized below:

No. Of Analog Channels	Max Sampling Rate	Main* Memory Depth	Auxiliary* Memory Depth	External Clock Input	Input Voltage Range	Pre-Trigger Data
1	50 MHz	1000 Samples	1000 Samples	1	5mV/DIV to 200 V/DIV	0-999 Samples

*The waveform analyzer uses the timing analyzer's main and auxiliary memories.

Like the state and timing analyzer sections, the waveform analyzer can be linked to other internal or external test and measurement functions.

1.4.5 Scope-Type Menu

Because it incorporates familiar, scope-like parameters, the waveform menu is easy to use. To record a waveform, select PROBE TYPE, (X1/X10), INPUT COUPLING, ATTENUATOR, DC OFFSET, TRIGGER LEVEL, and TRIGGER SLOPE. Next, select the Free Run or Single Shot mode and choose an appropriate sample rate, up to 50 MHz, (see Figure 1-15).

```

      WAVEFORM ANALYZER MENU

PROBE TYPE:  AC      INPUT COUPLING:  DC

VERTICAL ATTENUATION:  500mV /DIV

DYNAMIC RANGE:  -2.00V TO +2.00V

TRIGGER LEVEL (0-100% OF SCREEN):  50% = +0.00V

TRIGGER SLOPE:  

CLOCK: 500ns

USE TIMING MENU TO SELECT CLOCK, TRIGGER MODE & LINKAGE

SET ARM OR TRIGGER LINKAGE TO "W" FOR NON-AUTO-TRIGGER

TIMING CHANNEL A TRIGGER & ARM WILL BE SET TO DON'T CARE
IN COLLECTION

      F1          F2          F3          F4          F5          F6
PREVIOUS    NEXT        SELECT    DEFAULT    CONFIG    COLLECT
  
```

Figure 1-15. Typical NPC-800 Waveform Menu

When an incoming analog signal meets the threshold and slope requirements that you have set into the menu, the waveform analyzer triggers and collects 1000 samples. These samples are stored in the timing analyzer's memory and can be displayed in one of the following four formats: software-smoothed, raw sample points, software interpolated, or binary.

1.4.6 Easy Analog Measurements

Waveform display manipulation is similar to that used by the timing analyzer. A moveable, inverse video graticule at the bottom of the CRT indicates the position and amount of waveform being displayed relative to the entire 1000-sample data collection. For closer inspection, any waveform section can be magnified up to 20 times. Also, any point on the waveform can be selected as the origin so you can directly read instantaneous voltage and time value differences as you sweep the cursor across the screen, (see Figure 1-16).

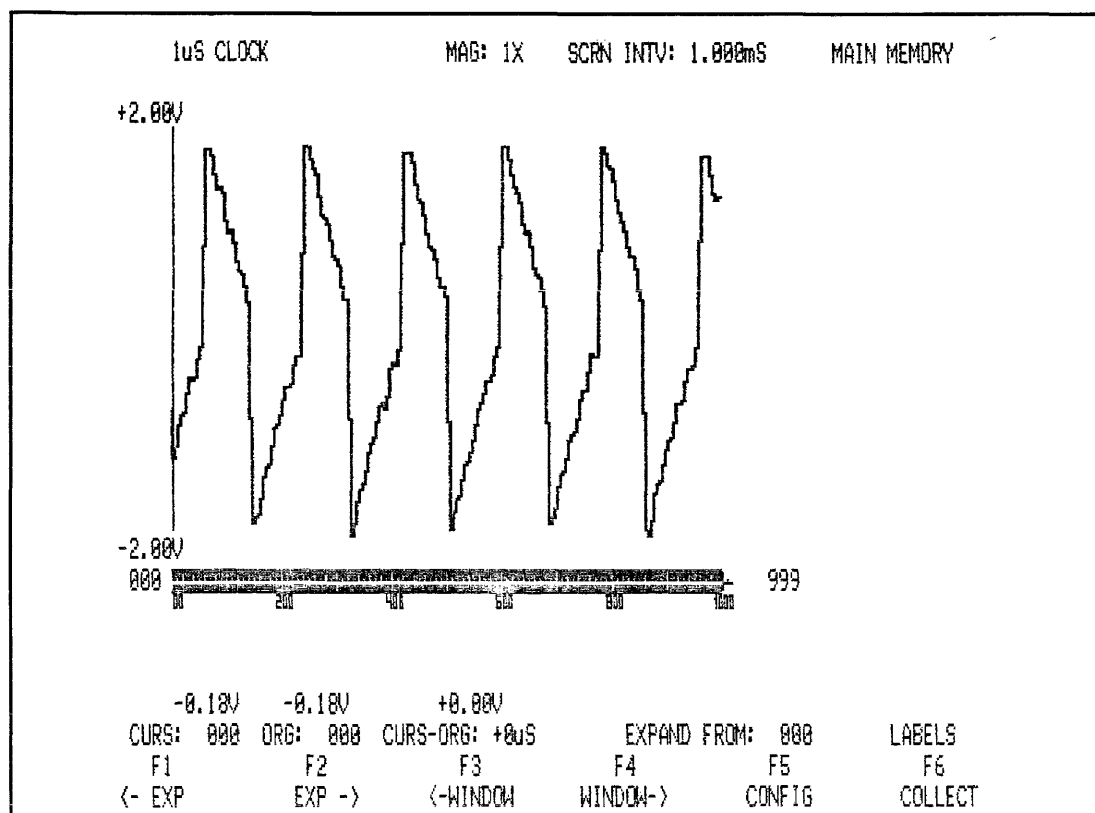

Figure 1-16. Typical Waveform Display

Similar to the state and timing analyzers, the waveform section allows you to store both the menu and a reference waveform for comparison testing. If you want permanent storage, the waveform and associated menu can be transferred to diskette. You can even label the waveform for easy identification when the test is later recalled.

1.4.7 Cross-Domain Analysis

Although the waveform analyzer is very useful as a stand-alone tool, its enormous debugging power becomes apparent when you link it to the state or timing sections of the NPC-800C. For example, when you need to examine closely the power-on characteristics of both the analog and digital portions of your system, you can set the waveform analyzer to trigger the state analyzer when the +5 volt power supply reaches a certain threshold. At this point, the NPC-800C simultaneously collects both the +5 volt signal and the associated power-up subroutine.

As a second example, you can use the state analyzer to trigger the waveform analyzer upon the occurrence of an I/O address. The waveform analyzer could then be used to monitor the output signal at a serial port, while the state analyzer is collecting the associated I/O subroutine.

1.4.8 Performance Monitoring

As hardware and software become more complex, the time your system takes to complete a given task becomes an important consideration. That's why the NPC-800's plug-in, counter-timer option is a useful performance monitoring tool during system test and integration.

1.4.9 Using Counter-Timer Plug-In

The counter-timer offers you a choice of four different modes of operation: FREQUENCY, PERIOD, INTERVAL, and TOTAL. For stand-alone operation, a single, scope-type probe allows you to make conventional counter-timer measurements at various points in your system, (see Figure 1-17).

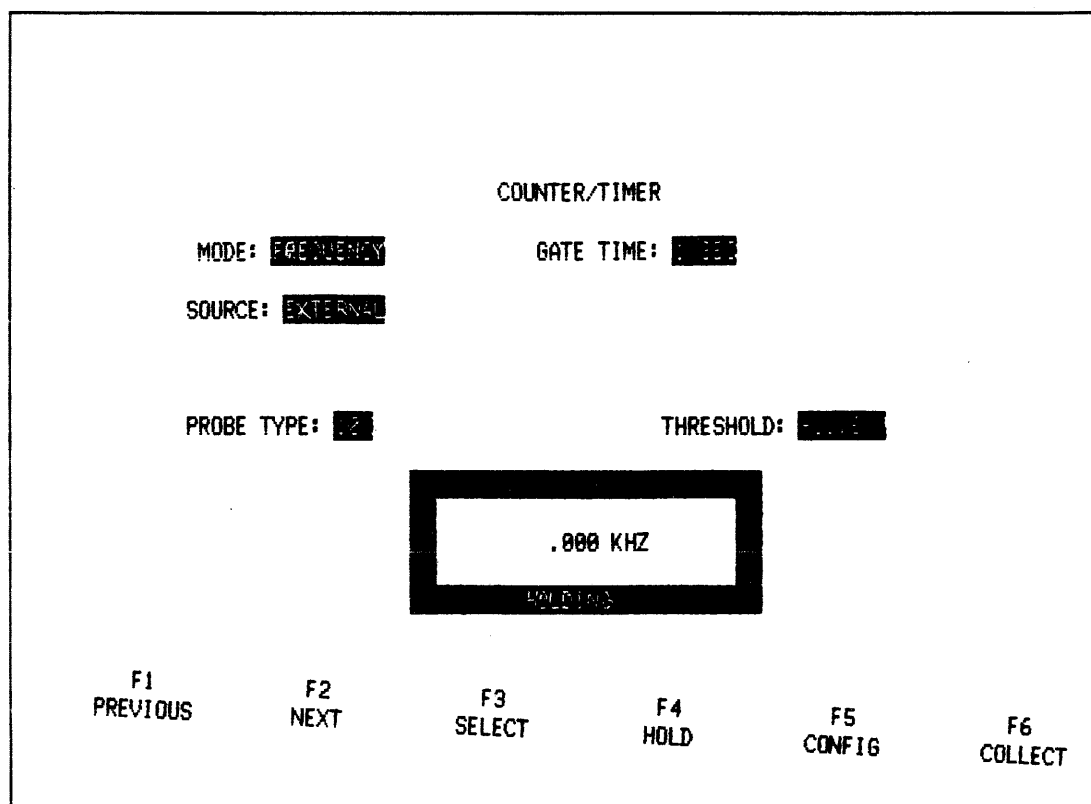

Figure 1-17. Typical Counter-Timer Menu

However, for more complex measurements, particularly those involving performance monitoring, the counter-timer can be linked to the state analyzer's word recognizers, allowing measurements to be made on the data coming into the three 16-channel state probes, (see Figure 1-18).

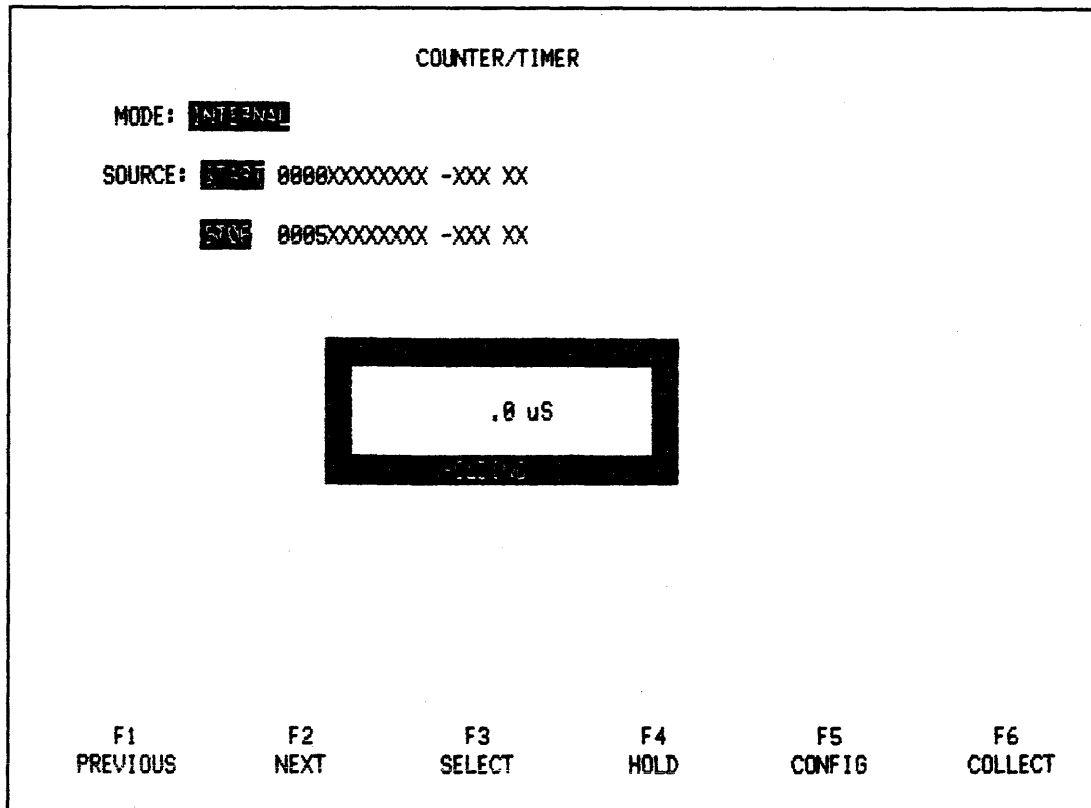

Figure 1-18. Measuring Interval Between Two State Events

Using this internal linkage mode, performance monitoring examples include measuring the frequency of occurrence or average period of a subroutine counting the total number of times a particular address or data word occurs during a program and determining the time elapsed during the execution of a particular segment of code.

1.4.10 Histograms

To be time and cost-effective analyzing system performance, NICOLET has provided software that gives a graphic presentation of statistical information collected from the target system under test. Using the state analyzer or the counter-timer hardware capabilities, this graphic display, in bar chart format, allows a broad overview of the target system.

The optional histogram feature allows use of the state analyzer in conjunction with the counter-timer hardware. This software operates in two modes, Event Histograms or Time Interval Histograms.

To monitor the relative time consumption in the target system, the Event Histogram mode allows you to select up to eight different events. These events are specified by the user as eight ranges, (such as address ranges). Then, when the logic analyzer is started, the state analyzer processes its clock qualifiers and trigger events while collecting data. Once the logic analyzer has filled its memory with data, the Event Histogram software examines the data to determine whether any of the data fits within any of the specified event boundaries and accumulates the quantity of data words within each event. Then the logic analyzer collects another set of data, repeating data examination and accumulation of occurrences of specified events, each time ending the examination with a bar chart display depicting the relative amount of time spent

within each event boundary by the target system. Because of an increasing statistical sample size, the longer the logic analyzer is allowed to monitor the target system the more accurate the histogram becomes, (see Figure 1-19).

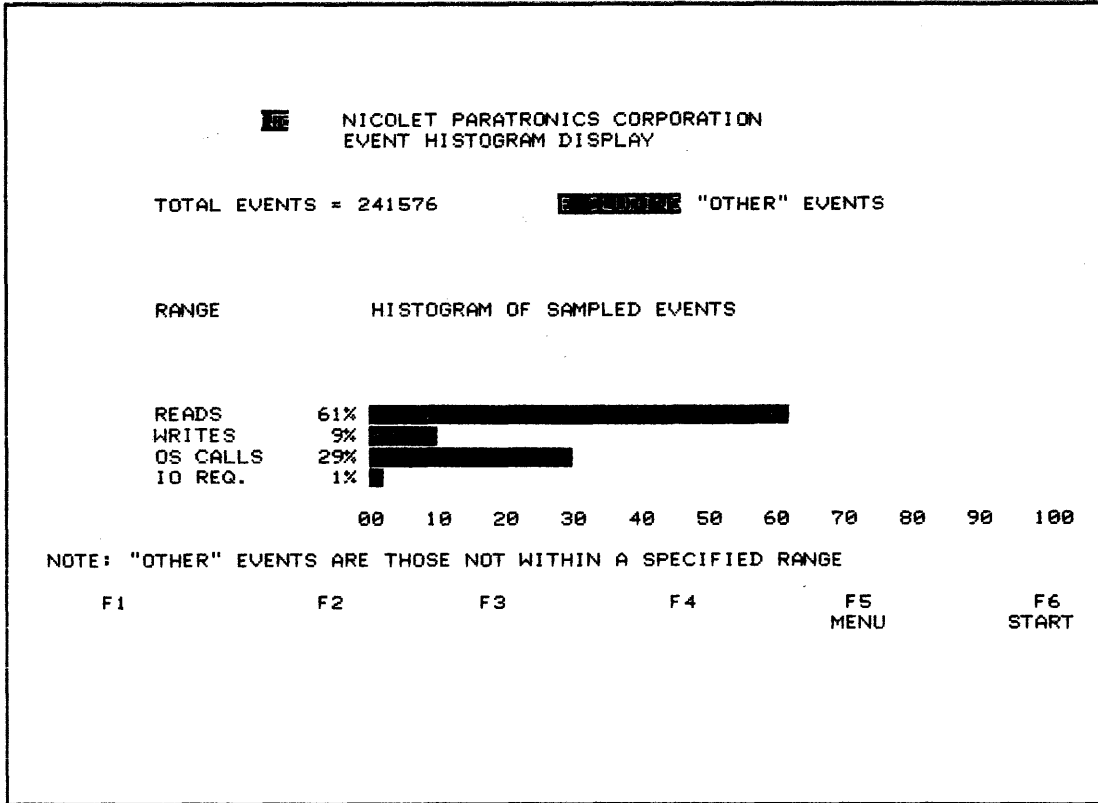

Figure 1-19. Event Histogram Bar Chart Display

The Time Interval Histogram software operates in a slightly different manner. The user specifies only one event, again a range with upper and lower boundaries. But this time the counter-timer measures the time interval between upper and lower boundary words. Therefore, the user also specifies up to eight ranges in time, (see Figure 1-20). Then, at each occurrence of the specified event, the counter-timer measurement is compared to each of the eight ranges in time. The quantity of occurrences within each range in time is accumulated and displayed in bar chart format.

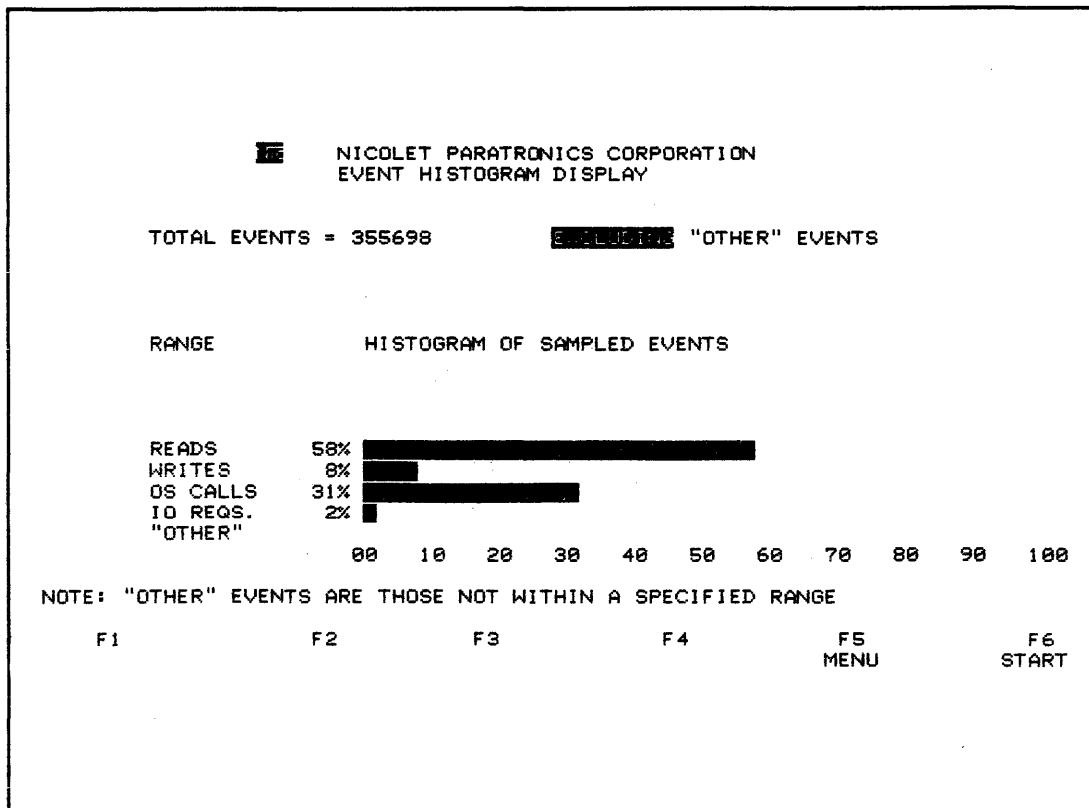

Figure 1-20. Time Interval Histogram Menu

Using the Event Histogram mode the NPC-800C provides an overview of the total performance of the target system. This mode also provides performance information on a single event within the target system, allowing the user to optimize software or hardware to achieve faster system operation.

1.4.11 Signature Analysis For Fault Isolation

The signature analyzer resides on the same plug-in board as the counter-timer. And like the counter timer, the signature analyzer can be linked to the state analyzer's word recognizers. This enables start and stop signals to be a minimum of one-bit wide, similar to conventional signature analyzers, or equal to the channel width of the state data probes.

With a one-bit start and stop signal, a single scope-type probe is used to monitor the serial data stream associated with each node in the circuit-under-test. This serial data stream, gated by the start and stop signal, is used to develop the four-digit signature, (see Figure 1-21).

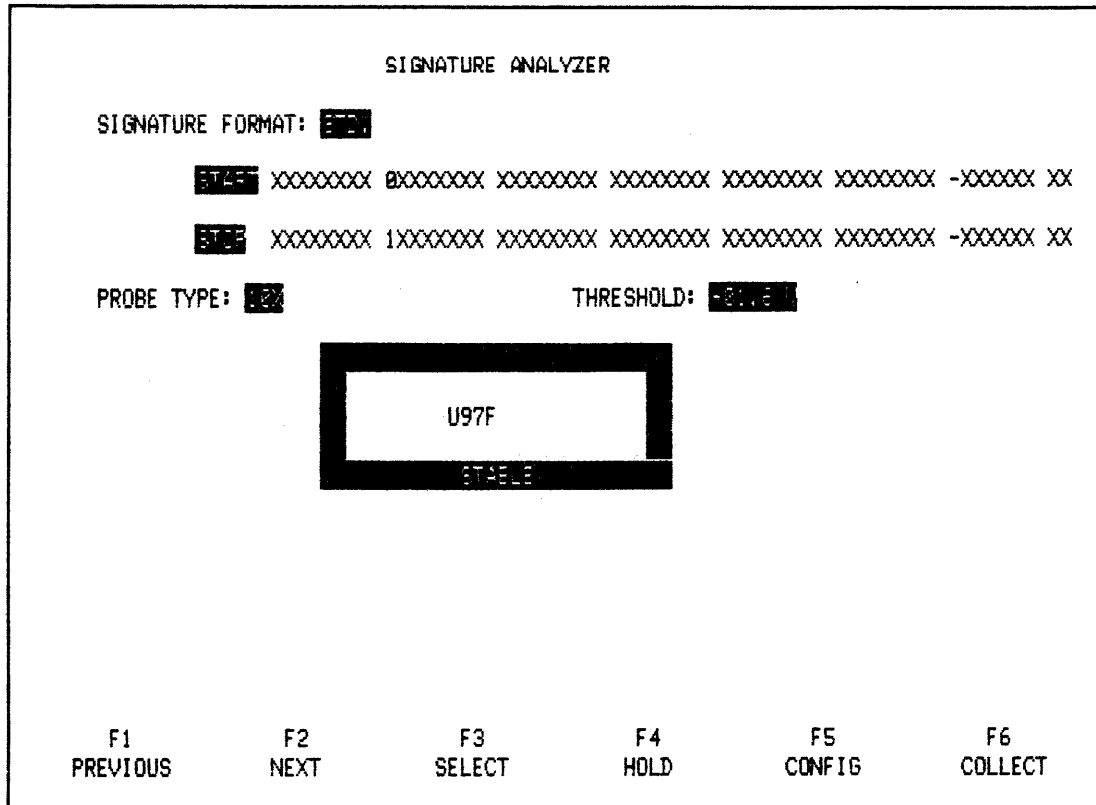

Figure 1-21. Simple One-Bit Signature Analyzer Menu

When the start and stop signal is more than one-bit wide, you can develop signatures of more complex events. For example, if the start word was a subroutine call address and the stop word was a subroutine exit address, a unique signature of that subroutine would be developed by using the LSB of the address as the input serial data stream. In this manner, software bugs or revisions can be readily identified, (see Figure 1-22).

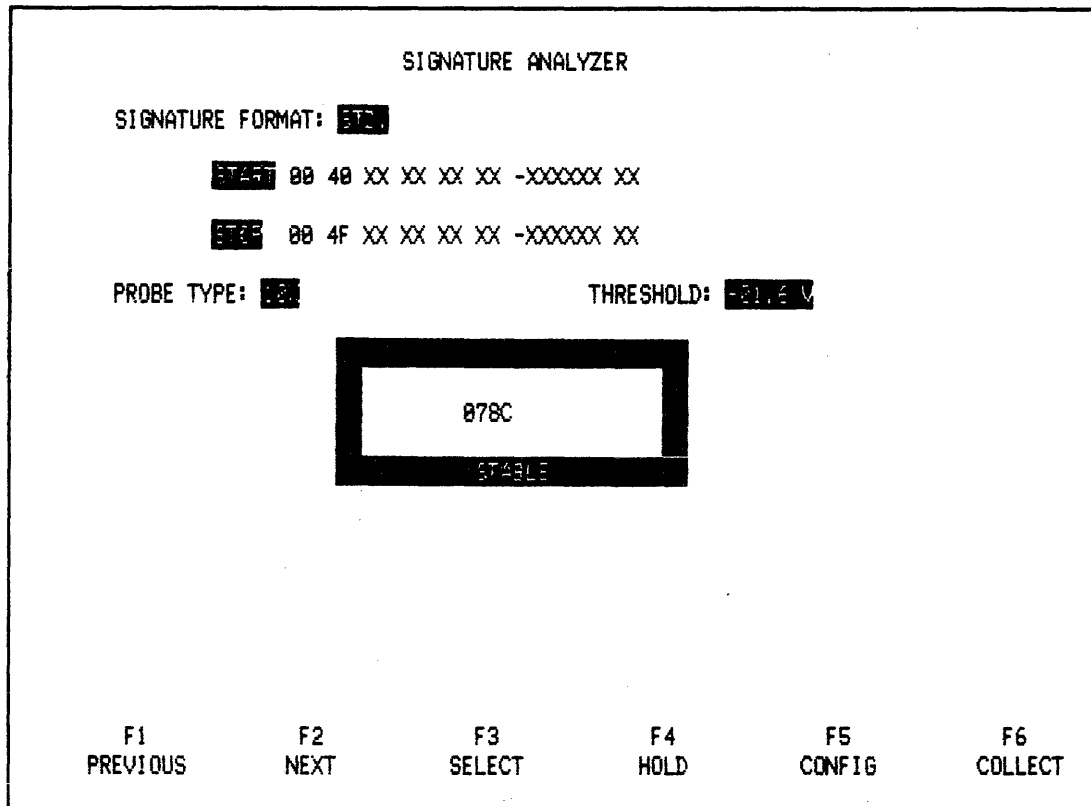

Figure 1-22. Signature Analyzer Menu For Developing Software Signatures

The algorithm that is used develops the same four-digit signature as other industry-standard signature analyzers.

1.4.12 Model 70 For Bidirectional Serial Testing

In many applications, the ability to troubleshoot an RS-232 interface is an essential part of the system testing task. The Model 70 Serial Communications Probe is a cost-effective way of adding bidirectional serial testing capability to your NPC-800C. Simply insert the Model 70's TEE connector between your computer and its peripheral and use the NPC-800's state analyzer and Model 70 transmit menu to capture, analyze, edit and transmit serial information, (see Figure 1-23).

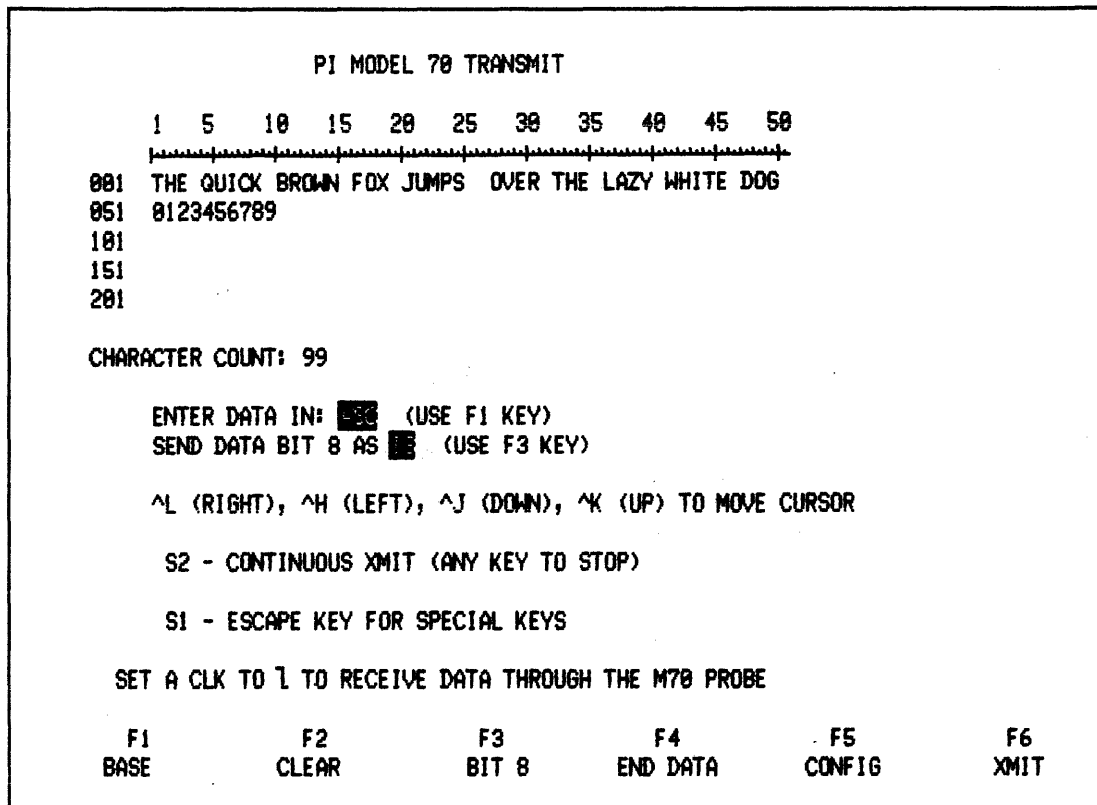

Figure 1-23. Model 70 Serial Transmit Menu

LED's on the Model 70 Serial Probe provide a real-time indication of the activity on the RECEIVE, TRANSMIT, and STATUS pins. Baud rates from 50 to 19.2K baud are switch-selectable on the probe. Other switches allow you to define pins 2 and 3 as RECEIVE or TRANSMIT, and to define the number of stop bits, parity, and word length (see Figure 1-24).

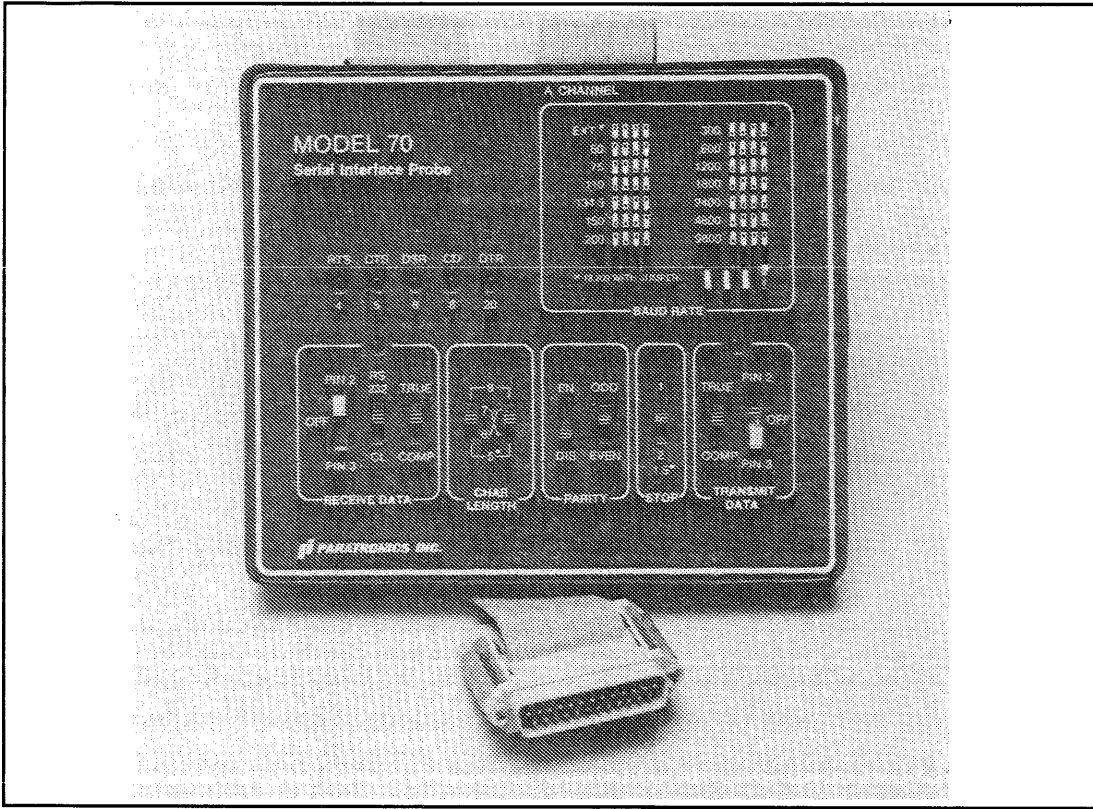

Figure 1-24. The Model 70 Serial Probe

The Model 70 Serial Probe only requires 16 state channels. Therefore, to support additional measurements in your system, there are 32 extra state channels, 16 timing channels, and other internal test functions.

As an example, assume you have a peripheral device that is not functioning properly. Is the problem in the computer, in the device, or in the interface itself? With the NPC-800C/Model 70 combination, you have all the resources you need to rapidly isolate the problem. Use the RECEIVE and TRANSMIT modes to identify the computer, the peripheral, or the interface as the source of the problem.

1.4.13 Eight-Bit and 16-Bit Dedicated Microprocessor Probes For Fast Software Debug

As the software used in system design grows, a logic analyzer and a dedicated probe with real-time disassembly capabilities become invaluable tools for analysis and debug. Real-time disassembly gives the user the ability to look at software execution at full system speeds. The data collected are then displayed in easy-to-read assembly language mnemonics.

1.4.14 Quick Connection

Using a pre-wired IC clip, each dedicated probe offers quick, Where space is a problem, a low-profile “piggy-back” socket is also available.

All necessary signals for clocking data into the NPC-800C are automatically generated by circuitry inside the probe. Data collection includes address, data, control and status lines. One example of a dedicated probe is shown in Figure 1-25.

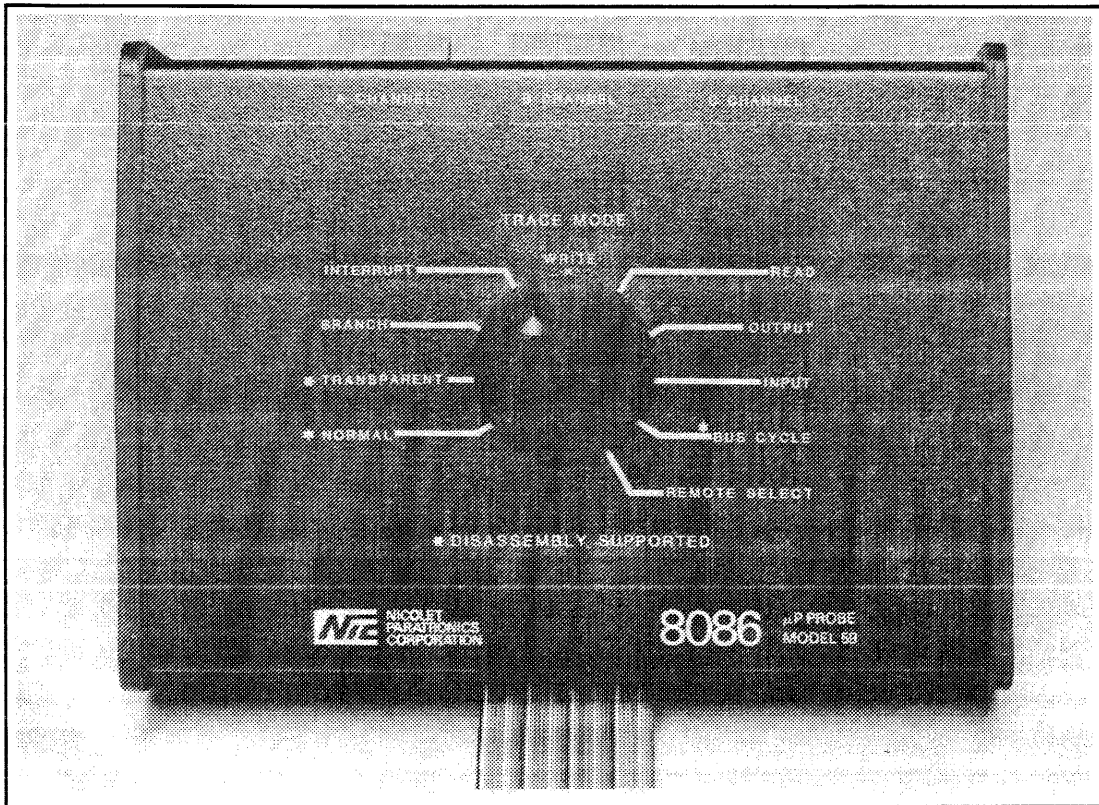

Figure 1-25. Dedicated Probe for the 8086

1.4.15 Powerful Analysis Capabilities

Used in conjunction with the dedicated probes, the NPC-800C's powerful clock and trigger qualifiers can simplify the analysis of your program's execution. With these qualifiers you can collect specific MPU operations or a combination of operations from among the following: MEMORY READ/WRITE, I/O, OPCODE FETCH, MPU STACK READ/WRITE, and BRANCHES, (see Figure 1-26).

MAIN	TRIG	0000		F3	OPCODE FETCH(TAIL)
		+001	0000	FF	REFRESH
LOC: TRIG		+002	0001	JP	0040H
		+003	0001	FF	REFRESH
SIG: E3D7		+004	0002	40	OPERAND FETCH
36E5		+005	0003	00	OPERAND FETCH
D8D3		+006	0040	LD	SP, 23FCH
		+007	0002	FF	REFRESH
		+008	0041	FC	OPERAND FETCH
		+009	0042	23	OPERAND FETCH
		+010	0043	LD	IY, 00A0H
		+011	0003	FF	REFRESH
		+012	0044	21	OPCODE FETCH(TAIL)
		+013	0004	FF	REFRESH
		+014	0045	A0	OPERAND FETCH
		+015	0046	00	OPERAND FETCH
		+016	0047	SET	7, (IY+55H)
		+017	0005	FF	REFRESH
		+018	0048	CB	OPCODE FETCH(INCOMPLETE)
		+019	0006	FF	REFRESH
		+020	0049	55	OPERAND FETCH
		+021	004A	FE	OPCODE FETCH(TAIL)
		+022	00F5	21	DATA READ

Figure 1-26. Typical Disassembly

Also, unwanted microprocessor activities, such as WAIT states and REFRESH cycles, can be purged from the data collection. Once set up, all modes are switch-selectable at the probe and require no further changes to the NPC-800C's menu. Additional software analysis capabilities include triggering on one operation, such as a BRANCH, and collecting a different operation, such as memory READS.

In relation to the actual operands and memory addresses being generated, all of the NPC-800C's 8-bit and 16-bit dedicated probes allow true, real-time disassembly of instructions being executed. Furthermore, NPC's dedicated probes do not interfere with real-time operation of the target MPU.

1.4.16 Advanced Analysis Capabilities

Depending on probe type, NPC's dedicated probes require 32 to 48 state channels. As shown below, this leaves the remaining channels and test functions for an in-depth analysis of events on or off the microprocessor bus:

Dedicated Probe Type*	Channels Required by Probe	Logic Analysis Channels Remaining
8080, 8085, Z80, 6809, 6809E, 6800, 6802	32 State	16 Timing plus 16 State
8086 8088 68000 General Purpose	48 State	16 Timing

For example, assume you are using the timing section to monitor a hardware interrupt subsystem and the state section to monitor the MPU. By linking the two sections, you can capture the interrupts while simultaneously disassembling the associated interrupt handling subroutine.

1.4.17 NPC-800C — A General-Purpose Computer

The NPC-800C departs from conventional test equipment by giving you full access to its internal microcomputer for automatic control, test storage, post-processing, and general-purpose computing applications.

The NPC-800C uses an 8085 CPU and two operating systems: one operating system is in ROM and supports all test and measurement functions; the other optional operating system, CP/M, resides on disk and supports all computer-related activities. These two operating systems are designed to interact during automatic testing, test storage, and post-processing of collected data.

Each stored test can incorporate comments, instructions, and other pertinent information. For example, in an engineering lab application, test comments could include date of test, name of engineer, test or probing procedures, and remarks. On the production line or in the field, step-by-step procedures can accompany stored tests to increase the productivity of test personnel.

*Contact Nicolet Paratronics Corporation for the availability of dedicated probes not listed.

```

A)ed autotest.sub
: #I
1: ;
2: ; TO THE OPERATOR: YOU'RE GOING TO PERFORM 3 TESTS.
3: ; IT'S IMPORTANT THAT YOU FOLLOW THE INSTRUCTIONS CAREFULLY.
4: ;
5: ; STATE TEST: AFTER READING THE INSTRUCTIONS BELOW, PRESS RETURN
6: ; WHEN THE CURSOR FLASHES. THIS WILL CALL THE STATE TEST
7: ;
8: ; A. CONNECT THE A STATE PROBE TO THE A SIDE OF THE TEST CARD.
9: ; B. WHEN THE CONFIGURATION LIST APPEARS, PRESS THE COLLECT KEY.
10: ; C. AFTER THE TEST IS COMPLETE, PRESS THE CONFIG KEY FOLLOWED BY THE
11: ; ESC KEY TO RECEIVE INSTRUCTIONS FOR THE NEXT TEST.
12: ;
13: ; REMEMBER, PRESS RETURN WHEN THE CURSOR FLASHES.
14: PAUSE
15: LARECALL STATE
16: ;
17: ; TIMING TEST
18: ;
19: ; A. CONNECT THE B TIMING PROBE TO THE B SIDE OF THE TEST CARD.
20: ; B. WHEN THE CONFIGURATION LIST APPEARS, PRESS THE COLLECT KEY.
21: ; C. AFTER THE TEST IS COMPLETE, PRESS THE CONFIG KEY FOLLOWED BY THE
22: ; ESC KEY TO RECEIVE INSTRUCTIONS FOR THE NEXT TEST.
23: ;
24: PAUSE
25: LARECALL TIMING
26: ;
27: ; WAVEFORM TEST (OPTIONAL)
28: ;
29: ; A. CONNECT THE SCOPE PROBE TO THE WF TESTPOINT ON THE TEST CARD.
30: ; B. AFTER THE CONFIGURATION LIST APPEARS, PRESS THE COLLECT KEY.
31: ; C. THIS COMPLETES THE TEST SERIES.
32: PAUSE
33: LARECALL WAVE
34: ;
35: ; #E
36: █

```

Figure 1-27. Simple Automated Test Program With Operator Prompts, Using Computer Option

```

DIR
A: PIP      COM : XSUB      COM : ED      COM : ASM      COM
A: DDT      COM : LOAD      COM : STAT      COM : DUMP      COM
A: SUBMIT   COM : PRINT      COM : KYBDTEST COM : FORMAT2   COM
A: CRUN23   COM : FORMAT1   COM : GPIBEX80 COM : LARECALL COM
A: UC2      COM : LASAVE      COM : LADISA    COM : CN2      COM
A: LA       COM : RANTEST    COM : SAVREC    COM : CRUN2     COM
A: CBAS     COM : XREF      COM : GPIBPS80 MAC : SAVREC80 MAC
A: GPIBPS80 REL : GPIBEX80 REL : SAVREC80 REL : SAVREC   ASM
A: GPIBEX   INT : GPIBEX80 BAS : LADISC80 BAS : GPIBEX   BAS
A: GPIB80   BAS : GPIB     BAS : LADISC   BAS : RS232EX  BAS
A: RS232EX  001 : PRIMARY   ONE : D6800    : D68000
A: D8085    : RS232EX  INT : D780    : D6809E
A: D488     : D8080     : D8086     : READ      ME
A: UC2      LST : PRIMARY    : SQ        BAS : 68000    DAT
A: SQ       INT : TERMINAL COM : EMMA     BAK : CTSA    BAS
A: 6809E    DAT : Z80      DAT : 8080    DAT : 8085    DAT
A: 8086     DAT : 6800    DAT : IEEE488 DAT : XFER     COM
A: INTRP    INT : INTRP    BAS
A>

```

Figure 1-28. Typical CP/M Diskette Directory (your listing may differ)

1.4.18 System Architecture

The NPC-800C incorporates a bus-oriented microcomputer architecture. Internal 8085 CPU, CRT, keyboard, memory and I/O subsystems, as well as the logic analyzer and other measurement functions, all interface to the CPU bus as shown in Figure 1-3.

Since the analyzer's control programs are contained in 48K of ROM, all test and measurement functions are totally independent of the CP/M operating system and the disk drive.

In contrast, all general-purpose computing tasks use the integral disk drive and the CP/M operating system as the primary interface. As shown in the figure, for execution, programs are downloaded into 48k of user RAM. It's important to note that this user RAM is separate from the real-time data acquisition memories associated with the state and timing analyzers.

The 9-inch CRT display is memory-mapped and uses an 80-character by 25-line format. A 256-character display generator provides full ASCII and graphics character sets.

1.4.19 CP/M Enhancement

Although there are hundreds of reasonably priced applications programs on the market offering higher level languages, engineering and scientific packages - even word processing, CP/M was chosen for the NPC-800C because it is the single most commonly used operating system.

Through CP/M, the user can also generate his or her own programs. These programs can be

written in assembly language or such high-level-languages as CBASIC*, FORTRAN, PASCAL, or PL/1.

A printer driver program is available that enables the NPC-800C to provide both text and graphics hardcopy on an Epson MX-80A printer. (Most of the illustrations in this manual were made using this program.)

In conjunction with its CP/M Operating System, the NPC-800C's computer option allows you to perform the following:

- Automatically execute a series of stored tests using simple CP/M commands or the built-in GPIB CONTROLLER. Standard IEEE-488 commands in CBASIC permit automation of internal test functions as well as control of external GPIB instruments.
- Execute commercially available CP/M application programs for solving engineering equations, circuit simulation, and report generation; even before hardware and software have been developed.
- Generate programs in CBASIC, FORTRAN, PASCAL, and other high-level languages to support your particular application. CBASIC is included at no cost with your computer option.
- Construct a low-cost, universal development system. Commercially available compilers and assemblers, and in-circuit emulators add software development capabilities to the NPC-800C.

1.4.20 Post-Processing Analyzer Data

Prior to the NPC-764 and NPC-800 Series, the logic analyzer user had to be satisfied with whatever data manipulation and display modes the manufacturer provided. However, through CP/M, post-processing programs can be written to support special applications. These programs can be generated in assembly language, CBASIC,* or other languages.

As a simple example, an applications program can be written to transfer previously collected data between the NPC-800C's state and timing sections. In this manner, you can display data collected by the state analyzer in a timing diagram format; or you can display state and timing data side-by-side on the same screen in the state format of your choice. Other post-processing examples include searching for certain patterns or sequences in the data collection, generating custom or nonstandard data displays such as histograms, and implementing special algorithms such as computing the Fourier transform of a previously-digitized analog waveform.

The commands that allow transferring of data between various analyzer memories and the 48k of user RAM are an integral part of the standard, NPC-800C I/O software described in the following pages. Besides allowing the manipulation of data within the NPC-800C, these commands also enable you to transfer normal or post-processed data to external GPIB or RS-232 devices.

1.4.21 The NPC-800C — A Low-Cost Development System

During the hardware and software integration phase of a project, a logic analyzer can be indispensable for uncovering subtle bugs. If the bugs are hardware-related, they can generally be fixed on the spot. However, if they are software-related, you may have to save up (and

*CBASIC is included with each computer option.

work around) enough bugs to make it worthwhile to halt the integration process and go back to the main development system to generate corrected code.

By adding a stand-alone emulator and a PROM programmer to your NPC-800C (equipped with the computer option), software bugs can be fixed as they occur. This can be a more efficient and effective way to perform software integration since the debugging process can proceed without the delays often associated with having to access the main development system. Both the emulator and the PROM programmer interface to the NPC-800C's RS-232 port.

With the above set-up, software changes can be quickly implemented and tested in your system. When the changes are successful, new PROMs can be programmed.

1.4.22 Automated Testing and Remote Control

A unique I/O software package, which allows the NPC-800C to be a central part of a powerful IEEE-488 automated test system, permits RS-232 MASTER/SLAVE operation in remote control applications. Additionally, the I/O software allows you to readily place the NPC-800C under the control of another computer.

1.4.23 Single I/O Menu Speeds GPIB and RS-232 Set-Ups

The I/O software, which is an integral part of the ROM-based test and measurement operating system, does not require the CP/M operating system during manual operation. The associated I/O CONFIGURATION MENU incorporates all of the fields necessary to manually set up the NPC-800C for GPIB and RS-232 operation. The menu consists of four quadrants: GPIB, RS-232, INPUTS, and OUTPUTS, (see Figure 1-29).

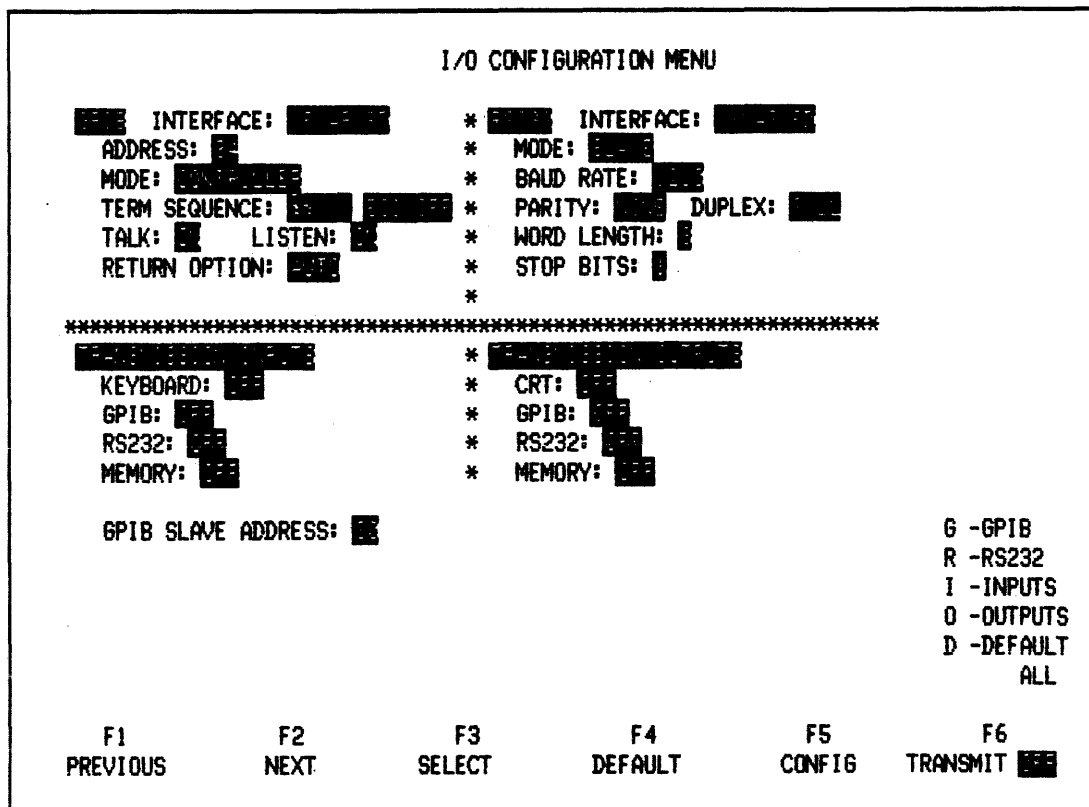

Figure 1-29. I/O Configuration Menu

On the GPIB quadrant of the I/O Configuration Menu, the NPC-800C can be set up as a CONTROLLER or a LISTENER/TALKER. On the RS-232 quadrant the instrument can be a MASTER or a SLAVE. In the TRANSMISSION INPUTS quadrant, data can come from the keyboard, from GPIB or RS-232 ports, or from various analyzer memories. Then, using the TRANSMISSION OUTPUTS quadrant, you can send data to the CRT, to various analyzer data memories, or out the GPIB or RS-232 ports. As a simple example of the use of the I/O CONFIGURATION MENU, consider an automatic test application that first required the manual to exercise an RS-232 or a GPIB device before running it under program control. By defining the NPC-800C's keyboard as the data input, and the NPC-800C's CRT as the output from the device under test, you can rapidly verify the integrity of your set-up.

1.4.24 GPIB Controller/Device Applications

When the NPC-800C is the central part of a GPIB-based, automated test system, the CP/M operating system, hosting CBASIC, is employed. These are typical GPIB commands:

ABORT	REQUEST	LOCAL LOCKOUT
GPIB	OUTPUT	CONFIGURE
RESET	ENTER	EOI STATUS
REMOTE	STATUS	SENBUS
LOCAL	SET TIMEOUT	TERM SEQ
TRIGGER		

When using these commands, it's important to note whether the NPC-800C's internal test and measurement functions respond as if they were external devices on the GPIB bus.

Thus, you can add a pattern generator, a DVM, a power supply, and other GPIB-compatible instruments to the NPC-800C and use the same command set for both internal and external functions.

If you already have an IEEE-488 controller, you can incorporate the NPC-800C into your GPIB test set-up as a powerful LISTENER/TALKER. In this configuration, the NPC-800C responds to standard GPIB commands from your controller, executes the required test, and transfers the results back again.

1.4.25 RS-232 Master/Slave Applications

Remote diagnosis is one new application area that is showing considerable promise. Using an ordinary terminal and a telephone line, a factory specialist can remotely control the entire operation of an NPC-800C. To avoid having to set up another communications link between the local and remote locations, any message typed at one location will appear on the CRT at the other location.

If the ordinary terminal is replaced by an intelligent terminal or a computer, then the NPC-800C's functions can be fully automated. In this application, a test can be downloaded to the NPC-800C and the results sent back to the intelligent terminal or computer for processing.

A third possible I/O configuration: use one NPC-800C as a MASTER and a second NPC-800C as a SLAVE. Here, the NPC-800C functioning as the MASTER can execute a test on System A while the SLAVE NPC-800C, following the commands of the MASTER, is running a test on System B. The MASTER can then command the SLAVE to report its test results. (One of the example programs provided with your NPC-800C Computer option actually performs this MASTER/SLAVE application.)

1.4.26 The NPC-800C — An Electronic Workbench

The table below summarizes how the NPC-800C performs test and measurement tasks previously requiring a bench full of sophisticated and expensive test gear.

Table 1-1. The Nicolet 800 Series Configuration Guide.

Function	NPC-800A	NPC-800B	NPC-800C	NPC-800D	NPC-800E
State Analyzer					
State Channels	32	48	48	48	
Clocking Speed	15MHz	15MHz	15MHz	25MHz	
Timing Analyzer					
Timing Channels	16	16	16	16	16
Max. Sampling Speed	100MHz	100MHz	200MHz	200MHz	200MHz
Options					
Non-Volatile Memory	Yes	Yes	Yes	Yes	Yes
Waveform Recorder	Yes	Yes	Yes	Yes	Yes
CT/SA	Yes	Yes	Yes	Yes	Yes
Second Disk Drive	Yes	Yes	Yes	Yes	Yes
Performance Analysis	Yes	Yes	Yes	Yes	Yes
Printer Software	Yes	Yes	Yes	Yes	Yes
Computer/Controller	Yes	Yes	Yes	Yes	Yes
Dot Matrix Printer	Yes	Yes	Yes	Yes	Yes

1.5 Basic Logic Analysis System Specifications

STATE ANALYZER

Channels: 48
Inputs: 48 data, 3 clocks, 6 qualifiers
Impedance: 44 Kohms/15 pF
Threshold Adj.: ± 6 V
Sense: TRUE OR COMP
Max. Input: ± 25 V
Min. Input Swing: 0.5 V
Synch. Clock Rate: DC to 15 MHz
Min. Clock Width: 20 nS
No. of Clocks: 3
Clock Qualifiers: 2 \times 55-bit words, logically OR'ed
Trigger Qualifiers: 8
Input Data:
 Set-up—20 nS
 Hold-time—0 nS
Main State Memory: 48 X 1000
Aux. State Memory: 48 X 1000
Pretrigger: 0 to 999 words
Triggering:
 No. of Levels—16

TRIGGER WORD—56 Bits wide
TRIGGER Sense—Choice of match or NOT match
Delay Value (n)—0 to 9999
Delay Modes—AFTER n clocks; NOT on n clocks; BEFORE n clocks; ON n clocks; OCCURS n times.
Hold / \neq —Displays data when main memory differs from aux memory
State Linkage:
 Internal—Link state to timing. Link state to waveform
 External—BNC Link to any other NPC logic analyzer or external equipment
Restart: 56-bit RESTART word
Trigger Status: State triggering progress displayed on CRT.
Test Codes (Sig): 3 four Digit Hex ID codes which represent data in memory using compression algorithm.
State Formats: Hex, octal, decimal, binary, ASCII, and mnemonics

Section 2

Preparation For Use

2.1 INTRODUCTION

This section provides precautions to observe during the initial installation of the NPC-800C. If you are a first time user of an NPC logic analyzer, it provides useful initial inspection, set-up, interconnections, packaging and shipment information (should it ever need to be returned for calibration or service).

2.2 INITIAL INSPECTION

BEFORE OPENING SHIPPING CONTAINER, inspect outside of container for damage. If container is damaged, keep it until a damage inspection of the logic analyzer and its accessories has been completed. This container was designed to ensure that your instrument would arrive in good condition. It is recommended that you store the container so that it can be used should the instrument require service or installation of other options.

If your logic analyzer is physically damaged, contact Nicolet Paratronics Corporation immediately to can arrange for repair or replacement. If container is also damaged, contact freight carrier.

Each NPC-800C receives a final inspection prior to shipment; a checklist identifies exactly what the shipment contains. Locate enclosed copy of checklist and confirm every item indicated on form has been received. If you cannot locate any of the items indicated, remember that some options are installed inside the analyzer; be sure to look inside pocket of accessory pouch.

To confirm that the NPC-800C is functioning properly, follow operating instructions (see Section 3).

2.3 PRECAUTIONS

2.3.1 Equipment Handling

The NPC-800C uses a modular construction in a rugged mechanical package. The operating environment temperature should be kept between 10° and 45°C (50° - 133°F). Also, do not use or store equipment in a dusty, smokey, or high static electricity areas. For the NPC-800C, as with other disk-based equipment, careful handling of diskettes and disk drive is recommended.

2.3.2 Programmable AC Voltage Selector Card

WARNING

1. BEFORE APPLYING POWER to the NPC-800C, make certain that programmable ac voltage selector card, which plugs into power module at rear of unit, is inserted in a position corresponding to the line voltage being used.

Also be sure PROPER FUSE IS INSTALLED. Correct fuse value for each voltage is printed on back of instrument, near fuse holder.

Otherwise, serious damage to internal switching power supply may occur.

2. DO NOT OPERATE this instrument WHEN THE TOP COVER IS REMOVED. Component failure may occur because of reduced cooling.

3. All service, other than that detailed in Section 2.3.5 should be performed only by trained maintenance personnel.

CAUTION

Failure to keep filter clean will result in excessive heat generation and equipment malfunction which may void your warranty.

Voltage selector card, shown in Figure 2-1, has three nominal voltage options: 100V, 115V, and 230V. The line voltage selected is visible without removing the card.

If it is necessary to change the line voltage, carefully grasp card edge with a pair of long-nose pliers and reorient it so that the proper voltage appears with card fully inserted.

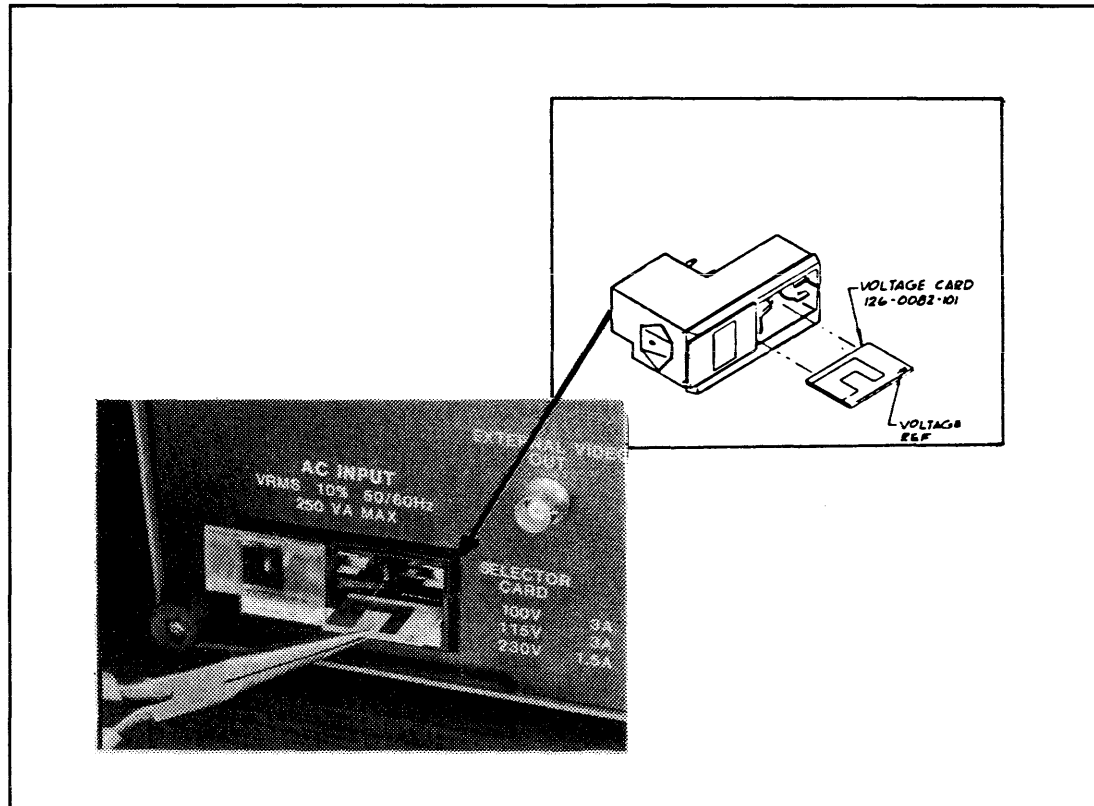

Figure 2-1. Programmable AC Voltage Selector

2.3.3 Handling of Diskettes

To protect the integrity of your data, menus, and programs, all diskettes should be handled with care. The following recommendations must be observed:

1. To avoid possible loss of information on the diskette, always dismount diskette from drive before NPC-800C power-up/down.
2. Return diskette to its storage envelope whenever it is removed from the disk drive.
3. Keep diskettes away from magnetic fields since exposure to such fields can affect data.
4. Do not write on plastic jacket with a lead pencil or ballpoint pen. Use a felt-tip pen or a stick-on label.
5. Smoke, heat and ashes from cigarettes can damage a disk.
6. Do not expose diskettes to heat or sunlight.
7. Never remove a diskette from its plastic jacket.
8. Do not touch or attempt to clean diskette surface because abrasions may cause loss of magnetized oxide and data.
9. Replace paper storage envelopes when they become worn, cracked, or distorted.

10. ALWAYS make a back-up copy of your diskette. ALWAYS buy good quality diskettes. They are worth the expense. Losing the only copy of a diskette, or losing a file because of accidental erasure, contamination, or poor quality media can be an expensive, and, possibly, an impossible situation to correct.

2.3.4 Write Protect Feature and Orientation

The WRITE PROTECT notch, when covered, protects the contents of the diskette from accidental alteration. A microswitch detects the presence or absence of a notch in the side of the diskette. When the open notch is sensed, writing is allowed. When the notch is not sensed (covered with a tab), writing is inhibited and a status signal informs the disk controller that a WRITE PROTECT condition exists.

2.3.5 Technical Assistance

Nicolet Paratronics' applications and service engineers are available should you need assistance with your instrument.

In Massachusetts, Maine, Connecticut, Rhode Island, and New Hampshire call 617-664-0355. In California call 415-490-8300.

Elsewhere in the USA call 800-NICOLET (800-642-6538)

Outside the USA, call your nearest Nicolet Paratronics Sales office.

2.4 INITIAL SET-UP

BEFORE APPLYING POWER to the NPC-800C, make certain that the Programmable AC Voltage Selector Card, which plugs into power module at rear of unit, is inserted in the position corresponding to the line voltage being used.

Also make certain that the PROPER FUSE IS INSTALLED. The correct fuse value for each voltage is printed on the back of the instrument, near the fuse holder. Otherwise, serious damage to the internal switching power supply may occur.

Install AC Power Card and turn on Power Switch, which is located on the side of the analyzer. Wait approximately 30 seconds for CRT to warm-up. A display of the Configuration List should appear on the CRT.

2.4.1 Screen Adjustment

To adjust CRT screen brightness and contrast, use the following procedure:

1. As an alternate way to obtain the CONFIGURATION LIST, press red RESET key for approximately two seconds. Then press F1 key labeled STATE to display state menu.
2. To accommodate ambient lighting conditions, adjust BRIGHTNESS and CONTRAST controls located at left of CRT. Make sure adjustments provide adequate contrast between half-intensity and full-intensity characters.

2.4.2 CRT Frame Rate Selection/50 Hz - 60 Hz

If CRT display appears shifted up or down, it is probably because setting of CRT FRAME RATE switch on Processor Board does not correspond to line frequency being used. Figure 2-2 shows location and settings of CRT FRAME RATE SELECT switch.

2.4.3 Frame Rate Select Switch

The dip switch is accessed by first switching off the ac power. Then remove top cover by loosening the two quarter-turn fasteners on rear of cover. Notice that card cage hold-down strap may have to be removed to change switch setting. Turn ac power on to check frame positioning. Reverse setting of S8, if necessary.

<u>CRT Frame Rate Select</u>	<u>S8</u>
50 Hz	OFF (Down)
60 Hz	ON (Up)

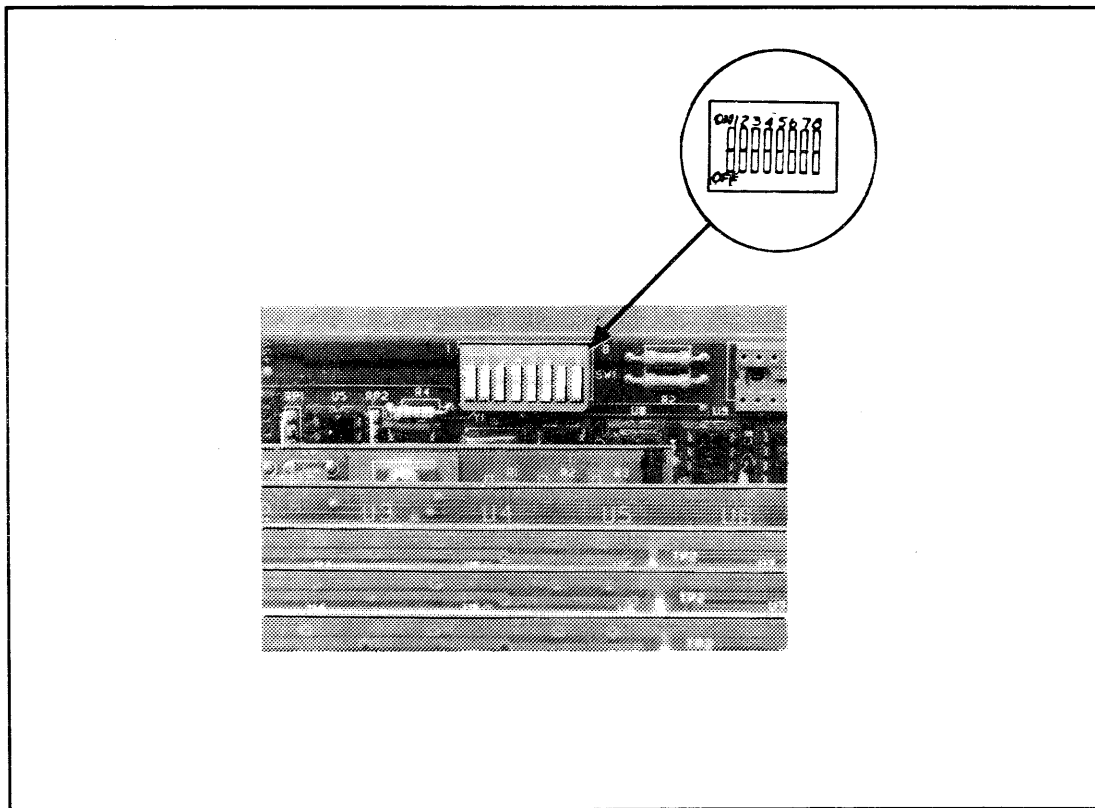

Figure 2-2. CRT FRAME RATE SELECT Switch On Processor Board

2.5 INTERCONNECTIONS

2.5.1 Input/Output Interface Ports

2.5.2 Probe Connections

The primary inputs to the logic analysis functions of the NPC-800C are the probe connectors located on left side of instrument, (see Figure 2-3). These ports are bidirectional, allowing the user to not only acquire data to be saved in the high-speed RAM of the analyzer, but also to output stimulus or data to his system under test via a user-supplied interface (probes are not bidirectional).

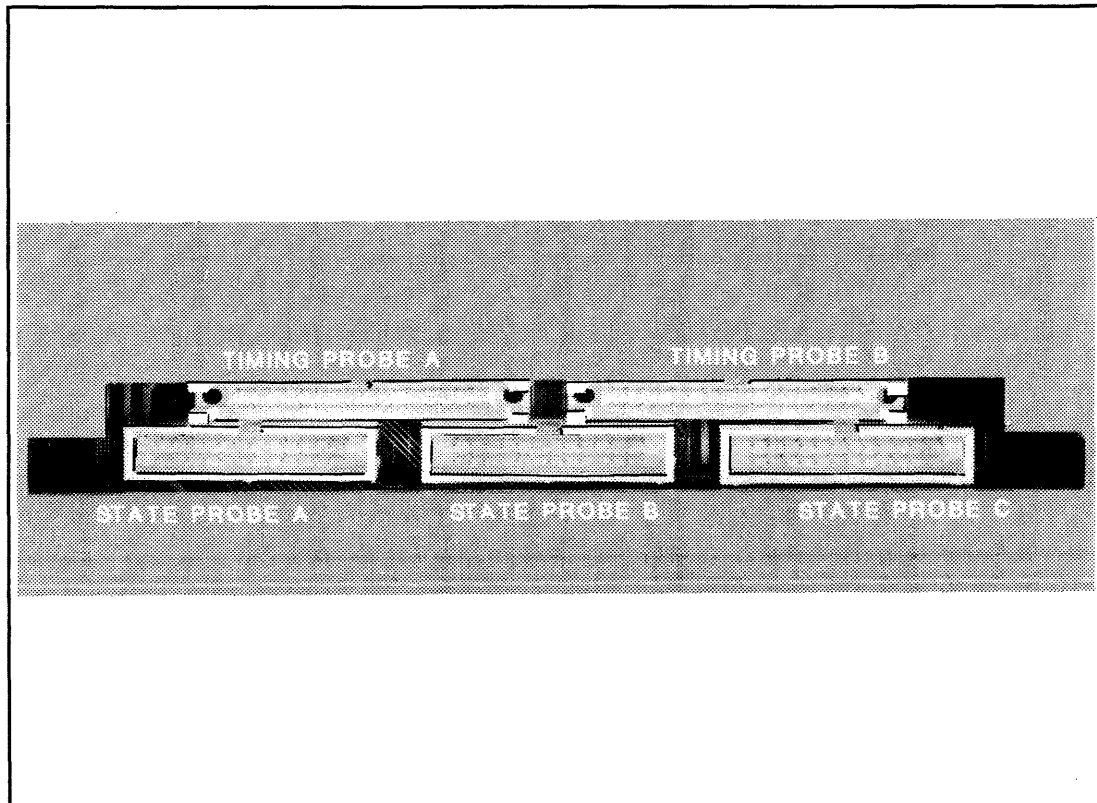

Figure 2-3. Probe Connections

2.5.3 External Video Out

This rear-panel BNC connector, shown in Figure 2-4, allows the NPC-800C user to display video information from the CRT on an external monitor. It can also be used to drive a video printer for hard copy documentation of menus and associated data. The output of this connector is a standard composite video. Its impedance is 75 ohms.

NOTE

The NPC-800C uses halflight reverse video in some menu fields. Certain video printers cannot reproduce these fields. To use these printers, short out 680-ohm voltage divider (R5) on top left portion of Processor Board (just below video connector). Use a shorting wire with miniature ball clips on both ends, or install a SPST switch. Remove short when printing displayed data.

2.5.4 RS-232C Serial Interface Port

As shown in Figure 2-4, the NPC-800C uses a standard EIA 25-pin connector to provide a bidirectional interface to RS-232C compatible devices (such as printers, PROM programmers, and emulators). Interface connection and internal switch settings are described in Section 3.20.6.

* RS-232C is included with the Nonvolatile Memory Option IEEE-488 CONNECTOR.

NOTE

An optional RS-232C software package for outputting text and graphics to an Epson printer is available. For details contact your local NPC sales office or the factory.

Included with each NPC-800C is a standard IEEE-488 (GPIB) interface. The NPC-800C is configured as a listener-talker device, unless the Computer/Controller option is also purchased. Paragraph 3.19.3 describes the operation of the NPC-800C on the bus.

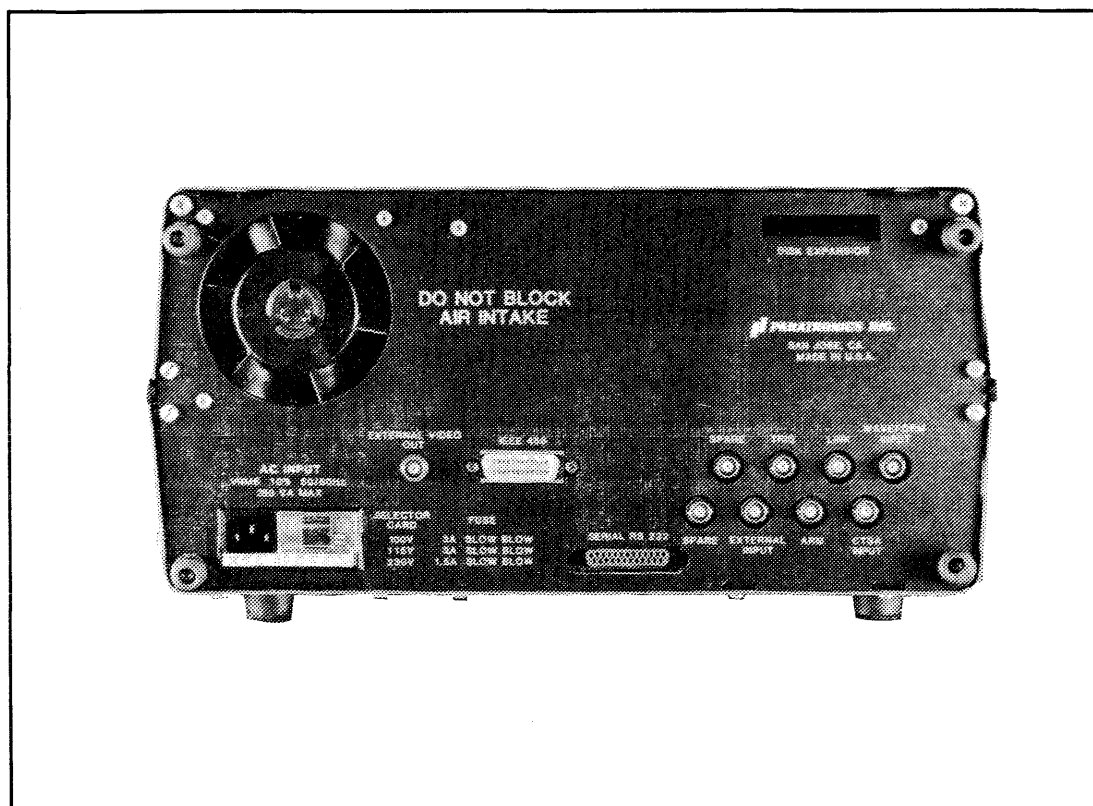

Figure 2-4. NPC-800C Rear Panel Connectors

There are several BNC connectors on the rear panel which provide inputs to various analysis functions or serve as outputs to external equipment such as an emulator or oscilloscope. They are as follows:

GND - Chassis ground terminal

WAVEFORM INPUT - Signal input to Analog Waveform Recorder option

CTSA INPUT - Signal input to Frequency Counter/Interval Timer/Signature Analyzer option

LINK - Bidirectional gate to send or receive a trigger signal to/from analyzer

ARM - Output from state logic analyzer trigger circuitry

TRIG - Output from timing logic analyzer trigger circuitry

EXTERNAL INPUT - Signal input to state and timing analyzer's trigger and clock qualification circuitry

SPARE - Two unused connectors

To allow up to two more external disk drives to be added to the system, there is also a DISK EXPANSION connector.

2.6 PACKAGING FOR SHIPMENT

YOU ARE RESPONSIBLE FOR DAMAGE TO THE NPC-800C WHILE IT IS BEING RETURNED TO NICOLET PARATRONICS CORPORATION. Therefore it is recommended that you use the original shipping container any time your instrument must be shipped. If you cannot locate original container, advise Nicolet Paratronics and another will be sent to you. If you cannot use the container supplied by Nicolet, you must use a strong carton with a shock absorbing material surrounding the instrument, approximately 3-inches thick on all sides.

Before shipping your instrument to Nicolet Paratronics Corporation, PLEASE RECORD THE FOLLOWING INFORMATION:

Company Name:
Address:
Technical Contact:
Phone Number:
Purchasing Contact:
Phone Number:
Purchase Order Number:

Model Number:
Serial Number:
Software Revision:
List of Accessories Returned:

Brief description of the failure (or work to be performed).

Then contact Nicolet to get authorization to return the instrument for service or other work. An example would be an option installation. Nicolet will provide you with a Return Material Authorization number. It will help expedite service to your instrument.

Nicolet can provide you with an estimate for repair charges prior to shipment to Nicolet. If you include a purchase order for that amount, it usually speeds up total repair time. If our estimate was too high, we invoice you only for actual charges. If our estimate was too low, we will contact you for permission to exceed the estimated charges.

2.7 SHIPMENT

Nicolet Paratronics has had good experiences with most of the popular freight carriers. HOWEVER, THE INSTRUMENT MUST BE PACKAGED PROPERLY.

If your instrument is still in warranty, you pay for shipment to Nicolet. Nicolet will pay the freight charges back to you.

If your instrument is out of warranty, Nicolet will pre-pay the freight charges, but will invoice you for that amount, along with the repair charges.

Section 3 Operation

3.1 INTRODUCTION

3.1.1 Menus and Displays

The power and ease-of-use of the NPC-800C Logic Analysis System results from the straightforward interaction of each menu with the keyboard. In fact, much of this section of the Operator's Manual is contained in the software which directs the user to the proper keystroke sequence. In general, keyboard entry of commands or data follows these basic guidelines:

1. The information displayed is always the current state of the analyzer.
2. Parameters that can be modified by the user are identified on the video display screen by a half-lit inverse video field.
3. Keyboard entries are placed into the menu at the position identified by a blinking cursor.
4. To move the cursor from one field to the next, use the PREVIOUS and NEXT keys.
5. To move the cursor within a field, use the SPACE BAR and BACKSPACE keys.
6. When some menus are displayed, F3 and F4 are labeled at the bottom of the CRT as SELECT and DEFAULT, respectively. Pressing SELECT causes each of the available options for that field to be selected. This simplifies the specification of some parameters and allows the user to scroll through all options to select the one most appropriate. Depending on the field, DEFAULT returns the field to the power-on condition or moves the cursor to the beginning of the field.
7. For immediate movement of the cursor to a nonadjacent field of interest in the menu, the DIRECT keys, C (CLK QUALIFIER), P (PRETRIG), and T (TRIG), can be used. In the Menu mode, pressing the S2 key followed by the LABELS key places a series of labels on the right side of the video display which define the function of each DIRECT key. Pressing one of the DIRECT keys calls the menu and steps the cursor directly to the corresponding field in the menu.
8. If an attempt is made to set up an illegal condition, an error message (in English) flashes on the CRT indicating which keys are appropriate for the current field. HELP (?)
9. In most data entry fields, pressing the ? key displays a prompting message on the screen indicating the type of data or commands that can be entered into the current field.

3.1.2 Analysis Examples

The NPC-800C was designed for ease-of-use. Upon application of power, the Analyzer's ROM-based operating system displays the CONFIGURATION LIST illustrated in Figure 3-1. This section of the manual provides the user with examples representing operational modes from this list.

```

NICOLET PARATRONICS 800C CONFIGURATION VER 3 REV D

1 - 48 CHNL STATE
2 - 16 CHNL TIMING
3 - 48 CHNL STATE/16 CHNL TIMING
4 - 8 CHNL TIMING GLITCH
5 - 48 CHNL STATE/8 CHNL GLITCH
6 - WAVEFORM RECORDER
7 - 48 CHNL STATE/WAVEFORM
8 - COUNTER/TIMER
9 - SIGNATURE ANALYZER
10 - PI 70 SERIAL PROBE TRANSMIT

ESC - INITIALIZE DISK SYSTEM

BREAK - PROCESSOR SELF-TEST

I - I/O CONFIGURATION MENU

F1          F2          F3          F4          F5          F6
STATE      STATE      STATE      SEL DOWN   SEL UP     COLLECT

```

Figure 3-1. Configuration List

The analysis examples in this section are structured for progressive self-study in that each step "builds" on the previous step. The Logic Analyzer Test Card, included with each NPC-800C, provides a known stimulus to the analyzer so that a given test set-up results in a predictable response.

If you have any questions, please feel free to call Nicolet Paratronics' Applications Engineers at the following locations:

- In Massachusetts, Maine, Connecticut, Rhode Island, and New Hampshire, call 617-664-0355.
- In California, call 415-490-8300.
- Elsewhere in the USA, call 800-NICOLET (800-642-6538).
- Outside the USA, call your nearest Nicolet Paratronics Sales office.

3.1.3 Function Keys

The six “soft” function keys labeled F1 to F6, from left to right, are identified by labels on the bottom line of the CRT. Their functions differ from menu to menu, but as the display changes their label on the CRT changes also.

3.1.4 Test Card Description

The Logic Analyzer Test Card is provided to allow you and your co-workers to rapidly familiarize yourselves with the basic and advanced features of the instrument.

The Logic Analyzer Test Card consists of two 8-bit CMOS counters (A and B), a clock, and simple decoding logic (see Figure 3-2). Each CMOS counter normally counts from (00)HEX to (FF)HEX. When the A counter reaches (40)HEX, the decode logic resets the B counter to (00)HEX.

The test card’s A channel connector is wired so that the 8 **least** significant bits toggle in a sequential fashion; while the 8 **most** significant bits are tied to ground. Therefore, the A channel connector provides a 16-bit word which covers the range from (0000)HEX to (00FF)HEX.

The test card’s B channel connector is wired so that its 16 output bits toggle nonsequentially. The following is a typical binary count sequence at the B channel connector:

COUNT	BINARY PATTERN*	HEX PATTERN
0	00000000 00000000	00 00
1	10000000 00000001	80 01
2	01000000 00000010	40 02
3	11000000 00000011	C0 03
■	■ ■	■ ■
■	■ ■	■ ■
■	■ ■	■ ■
15	11110000 00001111	F0 0F

Power to the test card is supplied by the +5V output at each probe connector.

* The A connector is generally used as a signal source for one state or timing probe; the B counter output feeds the second state or timing probe. For the NPC-800C, the third 16-channel state probe is not normally connected to the test card.

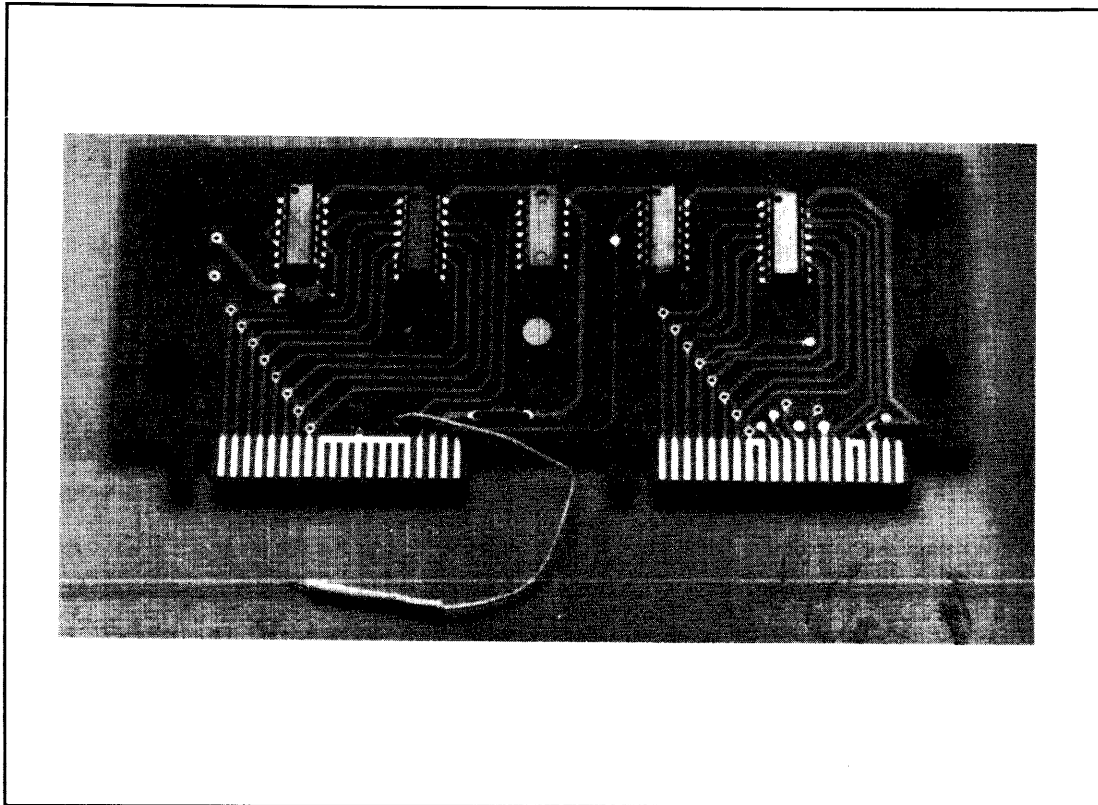

Figure 3-2. Test Card Layout

Owing to the difference in pin-outs between the 16-channel state probes and the 8-channel timing probes, this exact pattern will only be displayed on the NPC-800C when using the state probe.

3.2 OPERATION MODES

3.2.1 Configuration Options

To initialize all the NPC-800C functions and call the CONFIGURATION LIST, press RESET for two seconds. After the initialization cycle, the CONFIGURATION LIST is displayed and the cursor appears at the top of the list. Ten configurations are possible if the optional Counter-Timer/Signature Analyzer (CTSA) and Waveform boards are installed.

3.2.2 Configuration List Display

The parameters for each of the menus associated with the CONFIGURATION LIST are described in the remainder of this section. The user is encouraged to experiment with all test parameters, triggering modes, and display formats to gain more familiarity with the range and power of the instrument, using the Logic Analyzer Test Card supplied with the NPC-800C.

```

NIC NICOLET PARATRONICS 800C CONFIGURATION VER 3 REV D

  1 - 48 CHNL STATE
  2 - 16 CHNL TIMING
  3 - 48 CHNL STATE/16 CHNL TIMING
  4 - 8 CHNL TIMING GLITCH
  5 - 48 CHNL STATE/8 CHNL GLITCH
  6 - WAVEFORM RECORDER
  7 - 48 CHNL STATE/WAVEFORM
  8 - COUNTER/TIMER
  9 - SIGNATURE ANALYZER
 10 - PI 70 SERIAL PROBE TRANSMIT

ESC - INITIALIZE DISK SYSTEM

BREAK - PROCESSOR SELF-TEST

I - I/O CONFIGURATION MENU

F1          F2          F3          F4          F5          F6
STATE      STATE      STATE      SEL DOWN  SEL UP    COLLECT

```

Figure 3-3. Configuration List

In the above display, each line represents one possible configuration of the analyzer. Position the half-intensity cursor on the number of the configuration desired, using SEL DOWN (F4) or SEL UP (F5). Then press F1 to display the menu that will be used to establish the data collection parameters.

3.3 ON-LINE HELP

The NPC-800C provides help to the user in three ways. First, when you are specifying parameters in a menu and strike an invalid key, the NPC-800C automatically prompts you with the proper keystroke selection. Second, if you are not sure what keys are valid, any time the cursor is within a field of any menu, simply press the question mark key "?". The NPC-800C provides a prompt with all valid keystrokes. Third, any time you are in a state or timing data display, pressing the function key, "LABELS", displays on the right side of the screen, a menu of all valid keystrokes.

Nicolet has provided short, concise prompts to assist you throughout your logic analysis process. Once you have gained a basic familiarity with logic analysis, the prompts should virtually eliminate the need to refer to the operator manual.

```

USE 0-9 KEY          48 CHANNEL STATE MENU

FORMAT: ██████████ ██████████ ██████████ ██████████ ██████████ ██████████
          A ████
CLK SEL: A PRB: █ B PRB: █ C PRB: █    QUALIFIERS FORMAT: -AABBCC EL
CLK QUAL: ████
OR ████
PRE-TRIG MEMORY (0-999): ████ WORDS
RESTART: ████
TRIGGER:
0 ████████████████████ -XXXXXX XX
██████

S1 - DATA DISPLAY
F1 PREVIOUS      F2 NEXT      F3 SELECT      F4 DEFAULT      F5 CONFIG      F6 COLLECT

```

```

H - HEX
O - OCTAL
Z - DEC
N - BINARY
Y - ASCII
U - USER

```

Figure 3-4. HELP Prompt During State Menu Set-up

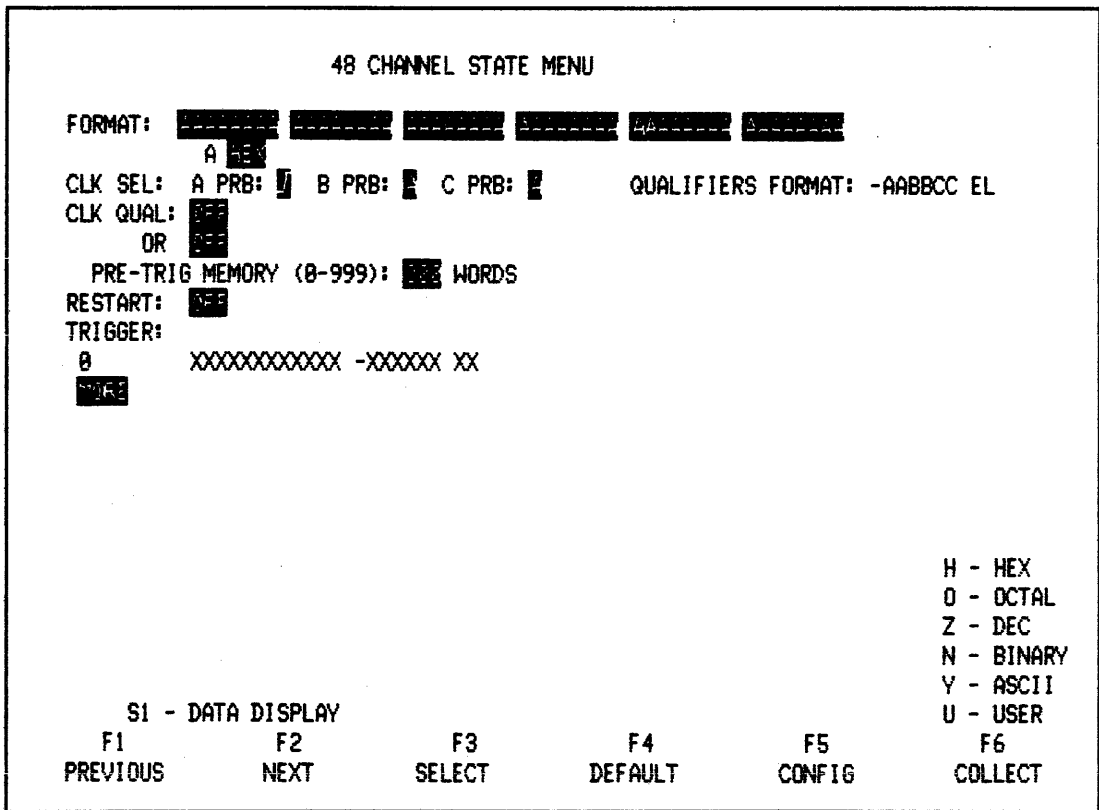

Figure 3.5 NPC-800C's 48-Channel State Menu (Flashing prompting messages are not shown)

3.4 STATE ANALYSIS

3.4.1 State Probe Connections

To illustrate basic state analysis capabilities of the NPC-800C, the user need only connect the test card, select the menu, enter in a trigger word, and press the COLLECT (F6) key. Captured data can then be formatted in a variety of ways.

Connect two state probes, A and B, to the NPC-800C. The A probe connector is located toward the rear of the analyzer, leaving the C probe disconnected.

Connect A probe to connector located on the left side of the test card and B probe to connector on the right side. Set switches on both probes for TRUE and TTL operation. Make sure grounded test lead on test card is not touching any circuitry.

3.4.2 State Logic Analysis Examples

Turn NPC-800C's power switch on to produce CONFIGURATION LIST illustrated in Figure 3-3.

3.4.3 48-Channel State Menu

3.4.4 To Call Menu:

1. press CONFIG or RESET key,

2. using SEL DOWN (F4) or SEL UP (F5) key, move cursor to the 48-CHANNEL STATE mode (if necessary), and then
3. press STATE (F1) key.

3.4.5 State Menu

If a clock is supplied by the system under test, state menu parameters are defaulted to values which enable a data collection to be made (without changing anything).

To make a state data collection, simply press COLLECT (F6) key.

3.4.6 Labels Key

To further simplify the operation of the NPC-800C, the LABELS key provides a list of valid keystrokes. After pressing LABELS key, observe (near top of list) that pressing T returns menu display and moves blinking cursor to the TRIGGER field.

Each of the keystroke options, which are listed when the LABELS key is pressed, will be discussed further on. For now, here is a description of the function of each:

CTRL C-AUTO	Initiates continuous data collection.
DIRECT KEYS	
C-CLOCK QUAL	C, P, or T causes state menu to be displayed, with cursor in the field: CLOCK QUALIFIER PRETRIGGER, or TRIGGER, respectively.
P-PRETRIG	
T-TRIG	
M-MEMSEL	M selects AUX or MAIN memories for display.
S-SAVE*	S writes MAIN memory data into AUX memory.
R-RECALL*	R returns previous menu data into AUX memory.

NOTE

These commands provide temporary data storage/recall functions using internal AUX RAM. The disk is not for these functions.

The HEX, OCT, DEC, BIN, ASC, and USER formats serve two basic functions: When used within a menu, bits in each data entry field are grouped into two digits corresponding to a selected format; when used with data, they control format displayed.

H-HEX	— Causes state data or a data entry field to be displayed in a hexadecimal format.
O-OCT	— Causes state data or data entry field to be displayed in an octal format.
Z-DEC	— Causes state data or a data entry field to be displayed in a decimal format.
N-BIN	— Causes state data or a data entry field to be displayed in a binary format.
Y-ASC	— Causes state data to be displayed in 7-bit ASCII format. (Leading bits are ignored.)

- U-USER — Causes mixed format defined in menu by user to replace current display.
 - 1-DISSASS — Causes data to be displayed in mnemonics of target micro-processor, (assuming that you are using a dedicated probe and have loaded corresponding software).
 - # - HOLD ≠ — Pressing # key calls HOLD ≠ mode. This mode is similar to COLLECT: it causes a data collection to be made according to parameters specified in the menu. However, in HOLD ≠ mode, data from current data collection (main memory) are compared to reference data in auxiliary memory (previously stored using SAVE key). If a difference is detected, the NPC-800C stops the data collection process and displays data.
- Differences in data can be highlighted on screen by using the DIFFERENCE function described below. If data in main memory are same as reference data, collection process is automatically repeated until a difference is found. The message SAMPLING is displayed while collecting data and the message HOLDING is displayed when a difference between MAIN and AUX memories has been detected.
- /-DIFFERENCE — Pressing / (DIFFERENCE) key once causes information in main memory to be compared to reference data in auxiliary memory. Data words that are identical are displayed at full intensity.
 - K-SEARCH UP,
J-SEARCH DOWN — K, SEARCH UP, and J, SEARCH DOWN are used in conjunction with SEARCH WORD mode described later.

3.4.7 Trigger (0040)

To format this field for a hexadecimal trigger word, press T and H keys. Now type in trigger word: 0040. Observe, from labels field at lower-right corner of CRT, that other display formats can be selected using indicated keys.

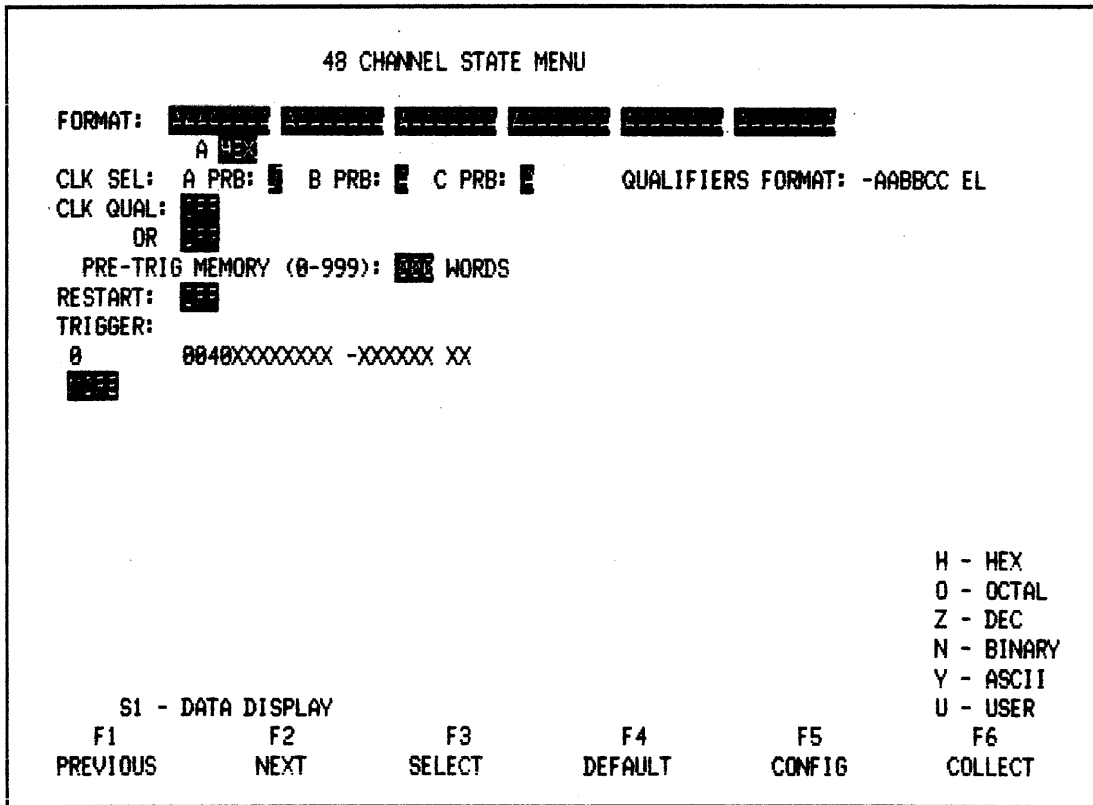

Figure 3-6. State Menu with 0040 Selected as Trigger Word

Press COLLECT (F6) key to take a new data collection. With state data displayed, word labeled TRIG at top of CRT should be 0040 for four most significant digits (ignore rest of word for now.)

3.4.8 Display Formats

Format display in octal, decimal, binary, and ASCII by pressing, in turn, O, Z, N, and Y keys. Press H key for hexadecimal format (see Figure 3-7).

```

MAIN      TRIG 0040FFFFFFFF
          +001 0041FFFFFFFF
LOC: TRIG +002 0042FFFFFFFF
          +003 0043FFFFFFFF
SIG: C1E7 +004 0044FFFFFFFF
D8D3     +005 0045FFFFFFFF
D8D3     +006 0046FFFFFFFF
          +007 0047FFFFFFFF
          +008 0048FFFFFFFF
          +009 0049FFFFFFFF
          +010 004AFFFFFFFF
          +011 004BFFFFFFFF
          +012 004CFFFFFFFF
          +013 004DFFFFFFFF
          +014 004EFFFFFFFF
          +015 004FFFFFFFFF
          +016 0050FFFFFFFF
          +017 0051FFFFFFFF
          +018 0052FFFFFFFF
          +019 0053FFFFFFFF
          +020 0054FFFFFFFF
          +021 0055FFFFFFFF
          +022 0056FFFFFFFF

```

Figure 3-7. State Data Collection with 0040 as Trigger Word

3.4.9 Mixed Display Format

The NPC-800C allows the user to intermix up to five different display formats. Thus, for example, you can display the address of an I/O port in hex, characters being output in ASCII, and associated handshaking signals in binary. You can also blank out any channel by placing an X in the appropriate bit position.

Now return to the STATE menu by pressing the T key. Use NEXT or PREVIOUS key to move cursor to FORMAT field at top of menu, and then set display format as follows:

AAAAAAAA AAAAAAAAA BBBB BBBB CCCDDDD DDDDEEEE FFFFFFFF

A=HEX B=ASC C=BIN D=HEX E=OCT F=DEC

(H) (Y) (N) (H) (O) (Z)

Now press S1 to return to data display of previous collection. Data are still displayed in last format selected, HEXADECIMAL. To select new user-defined display format, press U key. To return to hexadecimal format, press H key. Pressing U key returns user format.

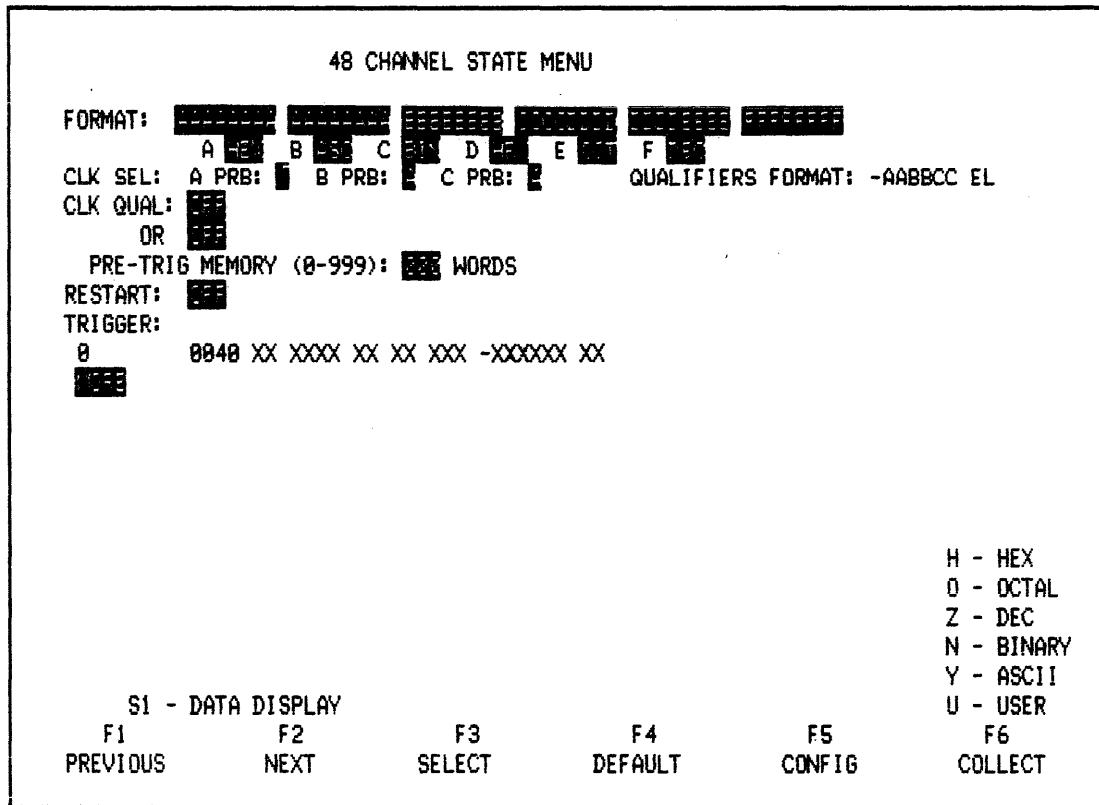

Figure 3-8. State Menu for Mixed Format Display

3.4.10 Saving Data (S Key)

To illustrate SAVE mode, press LABELS key in top row. Perform SAVE function by pressing S key. This action causes entire data collection, test codes (SIG), and menu parameters to be stored in the NPC-800C's auxiliary RAM memory (notice flashing SAVED message). Now press M key (MEMSEL) to cause auxiliary memory to be displayed. Press M again to return main memory to screen.

3.4.11 Signatures (SIG or Test Codes)

The analyzer uses a data compression technique to generate a unique four-character "signature" for the specific data-set in each memory board. That signature is displayed in the upper-left corner of the CRT. To compare MAIN and AUX memories, compare signatures. If signatures are different, then data-sets are different.

3.4.12 HOLD ≠ Mode (# Key)

HOLD ≠ mode is used to detect and isolate intermittent faults. Press # key (SHIFT and 3) to activate HOLD ≠ mode. Notice flashing status messages which indicate that analyzer is automatically collecting 1000 words and comparing main and auxiliary data.

Hold shorting wire on pad 5 on right-hand side (B side) of test card. Notice that flashing status message now reads HOLDING, and data are displayed. Remove shorting wire from pad 5.

3.4.13 Memsel (M Key)

Press M key to compare main and auxiliary test codes. Notice that one of the main memory test codes differs from corresponding auxiliary memory test code. This indicates that somewhere in the new data collection, there are one or more bits that differ between main and auxiliary memories. Now return to main memory indicated in upper-left of CRT.

3.4.14 Difference (/ Key)

DIFFERENCE mode is used for rapid identification of differences between main memory and previously-saved auxiliary memory data.

Press / key (under ? key) to activate DIFFERENCE mode, (this function toggles so that repeated keystrokes turn it on and off). In this mode, only data words, which differ between the main and auxiliary memories, are displayed at full-intensity, (data words that match are displayed at half-intensity). Press SCRL UP (F2) key to find first difference word.

3.4.15 LOCATE (F3)

For a rapid examination, the LOCATE key is used to move through data-set. The LOCATE key positions cursor at LOC field in state display. After pressing LOCATE key, the user enters a + or - followed by a three-digit number that represents word location in memory relative to the trigger word (which is then brought to top of screen). Pressing LOCATE and T places trigger word at top of screen; pressing LOCATE and B places beginning of state collection (not necessarily trigger word) at top of screen; pressing LOCATE and E places end of collection at bottom. Pressing LOCATE and D, when using the Difference mode, places first full-intensity difference line at top of screen. Repeating LOCATE and D moves next difference word to top of display. Pressing LOCATE and S places first half-intensity same word at top of screen (pressing LOCATE and ? displays all options).

3.4.16 Locate Difference (LOCATE D)

Press LOCATE (F3) followed by B, then LOCATE followed by D to place first difference word at top of screen (this is another faster way to locate the first difference word).

MAIN	+916	*00D0FFFFFFFF
	+917	*00D1FFFFFFFF
LOC: +916	+918	*00D2FFFFFFFF
	+919	*00D3FFFFFFFF
SIG: C137	+920	00D8FFFFFFFF
D8D3	+921	00D9FFFFFFFF
D8D3	+922	00DAFFFFFFFF
	+923	00DBFFFFFFFF
	+924	*00D8FFFFFFFF
	+925	*00D9FFFFFFFF
	+926	*00DAFFFFFFFF
DIFFERENCE	+927	*00DBFFFFFFFF
	+928	00E0FFFFFFFF
	+929	00E1FFFFFFFF
	+930	00E2FFFFFFFF
	+931	00E3FFFFFFFF
	+932	*00E0FFFFFFFF
	+933	*00E1FFFFFFFF
	+934	*00E2FFFFFFFF
	+935	*00E3FFFFFFFF
	+936	00E8FFFFFFFF
	+937	00E9FFFFFFFF
	+938	00EAFFFFFFFF
	+939	00EBFFFFFFFF

Figure 3-9. First Difference Word Occurs at +700 (Your example is probably different)

Press N key to view difference data in binary. Then press and hold M key to locate specific bits responsible for differences.

Now press LOCATE (F3) followed by S to find next group of half-intensified words that are the "same" (if any). Press SCRL DWN (F1) key once to verify this, (see Figure 3-10).

MAIN	+920	0008FFFFFFFF
	+921	0009FFFFFFFF
LOC: +920	+922	00DAFFFFFFFF
	+923	00DBFFFFFFFF
SIG: C137	+924	*00D8FFFFFFFF
D8D3	+925	*00D9FFFFFFFF
D8D3	+926	*00DAFFFFFFFF
	+927	*00DBFFFFFFFF
	+928	00E0FFFFFFFF
	+929	00E1FFFFFFFF
	+930	00E2FFFFFFFF
DIFFERENCE	+931	00E3FFFFFFFF
	+932	*00E0FFFFFFFF
	+933	*00E1FFFFFFFF
	+934	*00E2FFFFFFFF
	+935	*00E3FFFFFFFF
	+936	00E8FFFFFFFF
	+937	00E9FFFFFFFF
	+938	00EAFFFFFFFF
	+939	00EBFFFFFFFF
	+940	*00E8FFFFFFFF
	+941	*00E9FFFFFFFF
	+942	*00EAFFFFFFFF
	+943	*00EBFFFFFFFF

Figure 3-10. Word +704, First Word in Next Group of Data Words That are the "Same"
 (Your example will probably be different)

Return to main memory, press LOCATE followed by T to place trigger word at top of CRT. Then press / key to disable difference mode.

3.4.17 Locate End (LOCATE E)

Locate end of data collection by pressing LOCATE (F3) key followed by E key. Then locate word 738 by pressing LOCATE and typing 738 (remember to SHIFT to access + key or use SPACE BAR to step through + field). To examine rest of data, scroll up or down by pressing SCRL UP (F2) or SCRL DWN (F1).

NOTE

Space bar also causes data to scroll up. Backspace causes data to scroll down. Finish with trigger word at the top of CRT by pressing LOCATE and T. If you press wrong key and get an error message, you can use BACKSPACE and SPACE BAR key to edit the LOCATE field. Alternatively, you can press S1 to clear the field.

3.4.18 Search Word (F4)

Pressing SRCH WRD key, F4, provides a rapid method to locate a particular word or bit pattern within a data collection. Pressing SRCH WRD key activates Search Word menu, as shown in Figure 3-11.

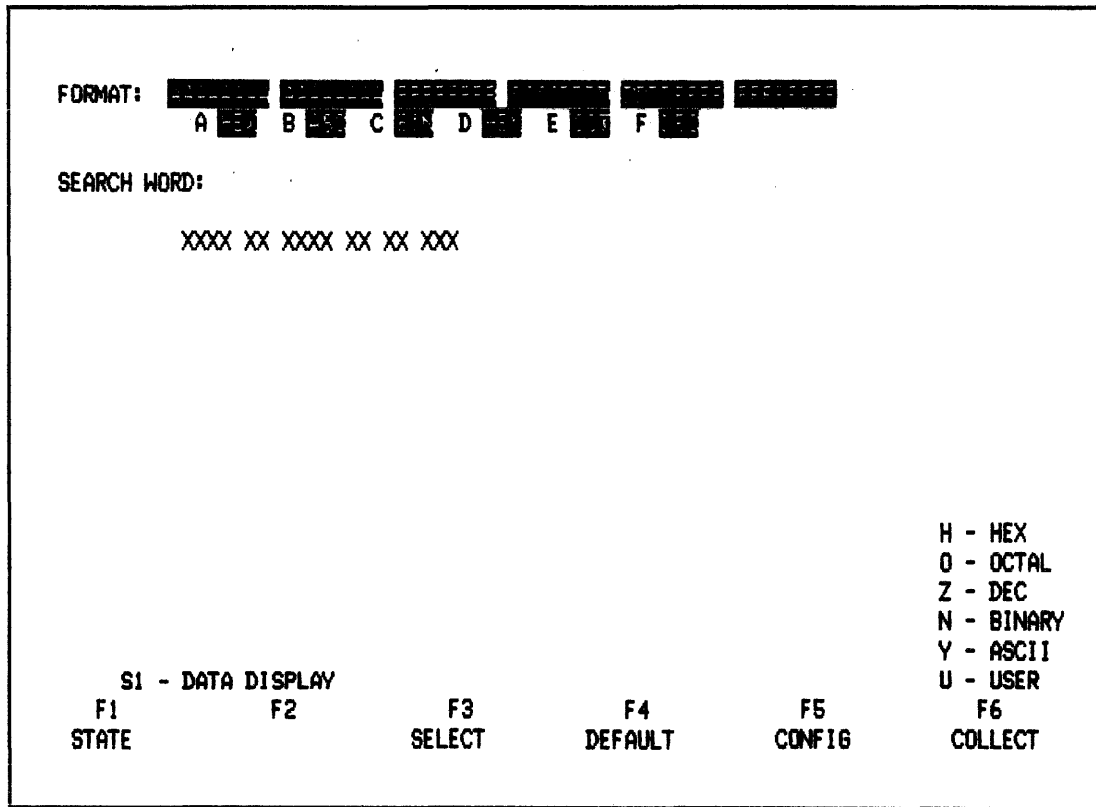

Figure 3-11. Search Word Menu

To allow changes in FORMAT field, press STATE (F1) which returns display to the STATE menu.

3.4.19 Configuration (F5)

CONFIG key causes CONFIGURATION LIST to be displayed again.

3.4.20 Collect (F6)

COLLECT key initiates a new data collection.

3.4.21 Search Word

SEARCH WORD mode allows you to locate any particular bit pattern within a data collection; you specify the word to search for and then the search direction.

Once desired word is entered in SEARCH WORD field, return to Data Display mode and press K (SEARCH UP) or J (SEARCH DOWN) key to initiate a search for that word in data memory. When SEARCH WORD is located, it is positioned at top of screen. Additional occurrences of SEARCH WORD are found by again pressing K or J key.

Press SRCH WRD (F4) key to obtain the menu shown in Figure 3-12.

FORMAT:	XXXXXXXX	XXXXXXXX	XXXXXXXX	XXXXXXXX	XXXXXXXX	XXXXXXXX
	A	HEX				
SEARCH WORD:						
	004EXXXXXXXX					
						H - HEX
						O - OCTAL
						Z - DEC
						N - BINARY
						Y - ASCII
						U - USER
S1 - DATA DISPLAY						F6
F1	F2	F3	F4	F5	F6	
STATE		SELECT	DEFAULT	CONFIG	COLLECT	

Figure 3-12. SEARCH WORD Menu with 009E as the Search Word

Press COLLECT to make a new data collection.

K, J

In this example, 004E is used as the word to be found in data collection. Type in 0-0-4-E (rest of field are X's--DON'T CARE.) Press S1 again to display data, then press K to search data for 004E (see Figure 3-13). Press K again to search for additional occurrences of 004E further down in memory. Press J to search in opposite direction.

MAIN	+014	00	4E	FF	FF	FF	FF
	+015	00	4F	FF	FF	FF	FF
LOC: +014	+016	00	50	FF	FF	FF	FF
	+017	00	51	FF	FF	FF	FF
SIG: C1E7	+018	00	52	FF	FF	FF	FF
D8D3	+019	00	53	FF	FF	FF	FF
D8D3	+020	00	54	FF	FF	FF	FF
	+021	00	55	FF	FF	FF	FF
	+022	00	56	FF	FF	FF	FF
	+023	00	57	FF	FF	FF	FF
	+024	00	58	FF	FF	FF	FF
	+025	00	59	FF	FF	FF	FF
	+026	00	5A	FF	FF	FF	FF
	+027	00	5B	FF	FF	FF	FF
	+028	00	5C	FF	FF	FF	FF
	+029	00	5D	FF	FF	FF	FF
	+030	00	5E	FF	FF	FF	FF
	+031	00	5F	FF	FF	FF	FF
	+032	00	60	FF	FF	FF	FF
	+033	00	61	FF	FF	FF	FF
	+034	00	62	FF	FF	FF	FF
	+035	00	63	FF	FF	FF	FF
	+036	00	64	FF	FF	FF	FF
	+037	00	65	FF	FF	FF	FF

Figure 3-13. Data Collection Showing 004E at Top of Display After Data Search Is Completed

3.4.22 Pretrigger

Use P key to access pretrigger field. Enter 0-0-3 into this field (see Figure 3-14).

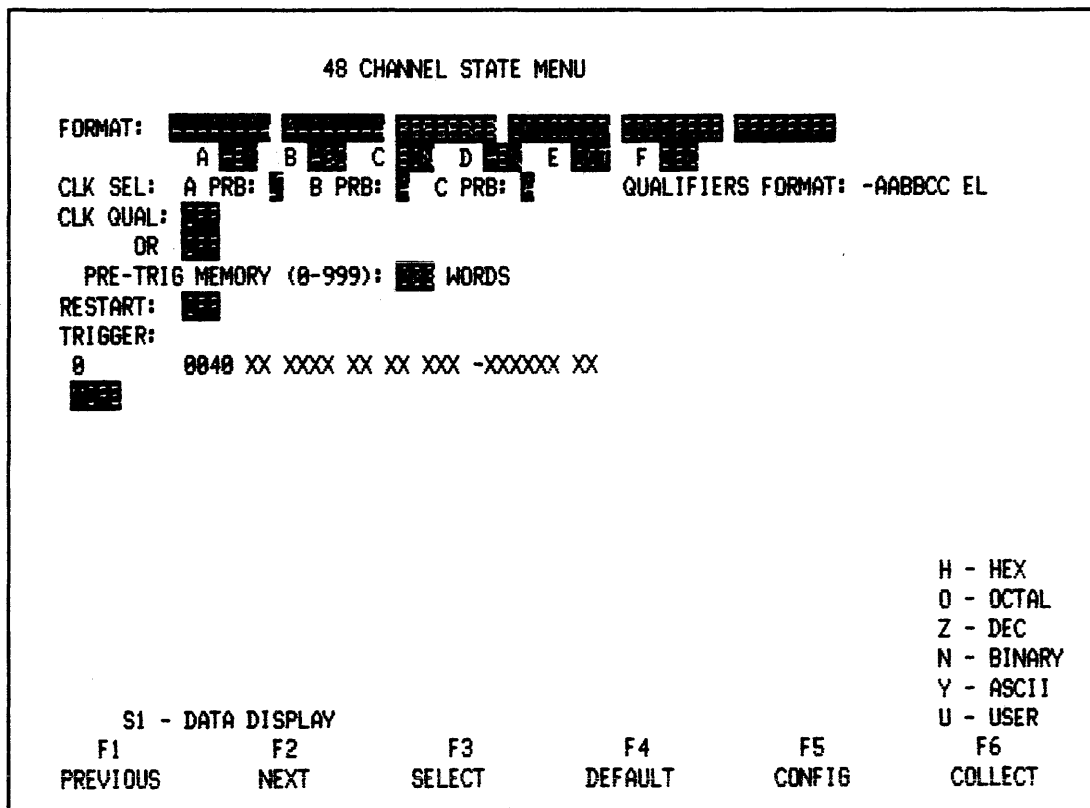

Figure 3-14. State Menu Set for Pretrigger Data Collection

To view pretrigger data, press COLLECT. Then press LOCATE and B keys. This causes first (or beginning) word in data collection (-003) to be displayed at top of display (see Figure 3-15).

MAIN	-003	00 3D FF FF FF FF
	-002	00 3E FF FF FF FF
LOC: -003	-001	00 3F FF FF FF FF
	TRIG	00 40 FF FF FF FF
SIG: C02F	+001	00 41 FF FF FF FF
D8D3	+002	00 42 FF FF FF FF
D8D3	+003	00 43 FF FF FF FF
	+004	00 44 FF FF FF FF
	+005	00 45 FF FF FF FF
	+006	00 46 FF FF FF FF
	+007	00 47 FF FF FF FF
	+008	00 48 FF FF FF FF
	+009	00 49 FF FF FF FF
	+010	00 4A FF FF FF FF
	+011	00 4B FF FF FF FF
	+012	00 4C FF FF FF FF
	+013	00 4D FF FF FF FF
	+014	00 4E FF FF FF FF
	+015	00 4F FF FF FF FF
	+016	00 50 FF FF FF FF
	+017	00 51 FF FF FF FF
	+018	00 52 FF FF FF FF
	+019	00 53 FF FF FF FF
	+020	00 54 FF FF FF FF

Figure 3-15. Pretrigger Data

3.4.23 Pretrigger Mechanism

Maximum pretrigger value is 999. For the NPC-800C, this means that as many as 999 words prior to trigger word can be collected. However, it should be noted that the NPC-800C's pretriggering mechanism is specifically designed so that any given pretrigger value reflects the **maximum** number of data words that can be collected prior to trigger. For example, if a pretrigger value of 10 was used, the amount of data words collected prior to the trigger could be anywhere between 1 and 10. This type of pretrigger mechanism is employed so that the user doesn't have to be absolutely certain when he presses COLLECT that at least 10 events are going to occur prior to trigger. If fewer events occur, data collection will still be accomplished and results displayed (other approaches cause data collection to be inhibited if an internal pretrigger counter is not allowed to count down to zero). Experiment with the NPC-800C's pretrigger mechanism by setting in a maximum pretrigger value. Then press COLLECT followed by LOCATE and B. Repeat this several times and note that the beginning word in data collection varies, depending on where the trigger word happens to be in the test card's 256-step count loop when you press COLLECT.

Press P to return to PRETRIGGER field and set this field to 000 (no pretrigger data). Press COLLECT. Then press LOCATE and T keys to return trigger word to top of display.

3.4.24 Sequential Triggering

The NPC-800C incorporates 16 levels of sequential triggering. One application of this feature is in the tracing of deeply-nested subroutines. Use T key to access TRIGGER field at level 0. Press NEXT key to access MORE field. Then press SELECT key to activate trigger word and

delay at level 1. * Set level 1 trigger word to 0-0-4-1. Then press NEXT key to access DELAY field. Use SELECT key to view the 5 possible delay modes: AFTER 0000 CLOCKS, NOT ON 0000 CLOCKS, BEFORE 0000 CLOCKS, ON 0000 CLOCKS, and OCCURS 0000 TIMES. Select ON 0000 CLOCKS and enter in delay value of 2049 (because counter on test card rolls over after 256 counts, any delay value, for example, 2049, that satisfies the equation:

$$\text{DELAY} = (N \times 256) + 1, \text{ where } N = \text{an integer, will work here}.$$

Set up levels 2 and 3 as shown in Figure 3-16 so that the entire trigger word sequence is as follows:

LEVEL	TRIGGER WORD	DELAY
0	0040	---
1 THEN	0041	ON 2049 CLOCKS
2 THEN	0042	ON 3073 CLOCKS
3 THEN	005A	AFTER 2000 CLOCKS

*An alternative to using SELECT key is to simply start entering data and the field will activate itself.

```

48 CHANNEL STATE MENU

FORMAT: ██████████ ██████████ ██████████ ██████████ ██████████ ██████████
        A HEX B DEC C BIN D HEX E OCT F DEC
CLK SEL: A PRB: █ B PRB: █ C PRB: █ QUALIFIERS FORMAT: -AABBCC EL
CLK QUAL: █
OR █
PRE-TRIG MEMORY (0-999): █ WORDS
RESTART: █
TRIGGER:
1 THEN 0041 XX XXXX XX XX XXX -XXXXXX XX ON 2049 CLOCKS
2 THEN 0042 XX XXXX XX XX XXX -XXXXXX XX ON 3073 CLOCKS
3 THEN 005A XX XXXX XX XX XXX -XXXXXX XX AFTER 2000 CLOCKS
██████

S1 - DATA DISPLAY
F1 PREVIOUS F2 NEXT F3 F4 F5 CONFIG F6 COLLECTOR
H - HEX
O - OCTAL
Z - DEC
N - BINARY
Y - ASCII
    
```

Figure 3-16. Menu Used for Sequential Triggering

3.4.25 Collection Status

Press COLLECT. Status messages on bottom of display show the user how the NPC-800C is

progressing through the triggering sequence. Also notice how the use of a slow CMOS counter circuit in the test card and large delay values allow these messages to be readily viewed. Observe that the trigger word is 005A; the last word specified in the trigger stack (see Figure 3-17).

MAIN	TRIG	00	5A	FF	FF	FF	FF
	+001	00	5B	FF	FF	FF	FF
LOC:	TRIG	+002	00	5C	FF	FF	FF
	+003	00	5D	FF	FF	FF	FF
SIG:	C2BF	+004	00	5E	FF	FF	FF
	D8D3	+005	00	5F	FF	FF	FF
	D8D3	+006	00	60	FF	FF	FF
		+007	00	61	FF	FF	FF
		+008	00	62	FF	FF	FF
		+009	00	63	FF	FF	FF
		+010	00	64	FF	FF	FF
		+011	00	65	FF	FF	FF
		+012	00	66	FF	FF	FF
		+013	00	67	FF	FF	FF
		+014	00	68	FF	FF	FF
		+015	00	69	FF	FF	FF
		+016	00	6A	FF	FF	FF
		+017	00	6B	FF	FF	FF
		+018	00	6C	FF	FF	FF
		+019	00	6D	FF	FF	FF
		+020	00	6E	FF	FF	FF
		+021	00	6F	FF	FF	FF
		+022	00	70	FF	FF	FF
		+023	00	71	FF	FF	FF

Figure 3-17. Data Collection Corresponding to Sequential Triggering Example

3.4.26 Force Display

When the 1000-word-deep state data memory is full, if triggering conditions are met, the message TRIGGERED is briefly displayed, followed by the message DONE. If sequential trigger stack is used and triggering conditions are not met at a particular trigger level, that level is identified and data are not displayed.

If there is not enough incoming data to fill 1000-word state memory, press F key and the amount of data words actually collected is displayed. If no input clock is being detected or if clock period is greater than approximately one second, the message WARNING-SLOW CLOCK 0000 will be displayed.

3.4.27 Nonoccurrence Triggering

Press T and NEXT keys to step to trigger level 1. Then use SELECT key to choose Nonoccurrence Triggering mode. Trigger word for level 1 will now be displayed as follows:

0041 X X XXXX XX -XXXXXX XX.

This mode can be used to trace program sequences when expected events are not occurring. In this example, the analyzer would pass through level 1 only if 0041 did not occur precisely 2049 clocks after 0040. Nonoccurrence triggering is available at each of 16 levels.

NOTE

In the non-occurrence Triggering mode, qualifiers do not change sense.

3.4.28 Auto-Restart

The above set-up demonstrates one of the subtle features of the NPC-800C. Frequently a certain sequence of events is expected, similar to the one specified above. However, because of the intermittent nature of the problem, as the analyzer progresses through the trigger stack, it comes to a point where trigger conditions **CANNOT BE SATISFIED** (in the above example something other than 0041 exactly 2049 clocks after 0040 is expected).

If 0041 occurs exactly 2049 after 0040, that stack level is not satisfied, and never will be. Therefore, the NPC-800C automatically **RESTARTs** back at level zero, and begins searching again.

Press **COLLECT** and observe that data are not collected, and collection status cycles from trigger stack level 0, to level 1, then back to level 0 again.

3.4.29 Force Trigger

Anytime the analyzer cannot satisfy a given trigger condition, (as this one), pressing **F** key forces analyzer to trigger, displaying all data collected to that point. Press **F**, **LOCATE**, and **B** to see data collected in this example. **TRIGGER** word is last word collected before **F** key is pressed.

3.4.30 Trigger Disable

Press **T**, **NEXT**, and **SELECT**. Notice that all trigger levels at cursor and below disappear. Should you desire to turn off part of trigger stack, **SELECT** key disables word recognizer circuitry, but does not clear register. Press **SELECT** again to enable the word recognizers that still contain previous values.

Press **COLLECT**, **LOCATE**, and **T** to prepare for next step.

3.4.31 Restart

When tracing program flow, there can be several paths leading to the same point in the program. The restart feature of the NPC-800C gives you control over which path will be actually traced by the analyzer to get to the desired trigger point (Figure 3-18 illustrates this concept).

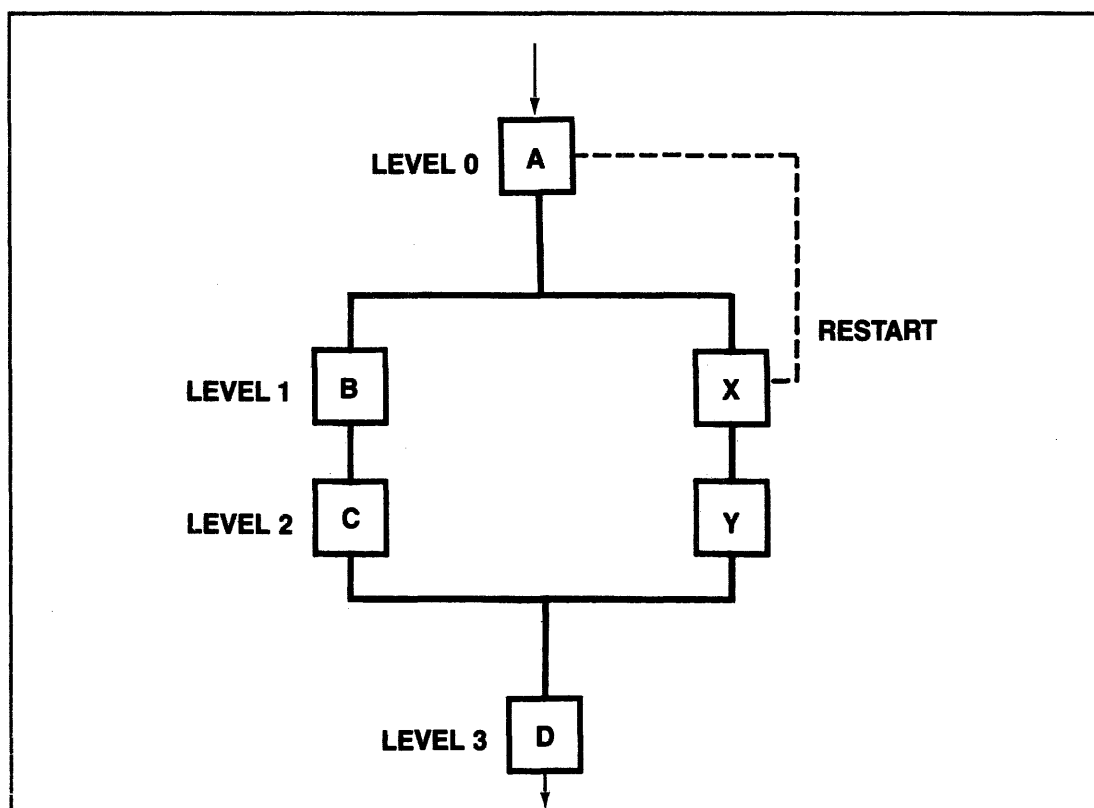

Figure 3-18. Using RESTART Feature to Ensure Program Path A-B-C-D Is Followed

3.4.32 Restart Example

Suppose that to get to point D, the program in Figure 3-18 can follow either path A-B-C-D or path A-X-Y-D. If the trigger stack is set up to trace path A-B-C-D but path A-X-Y-D occurs, the analyzer will be “hung-up” at level 1 because event B never occurred. The restart feature is used to reset the stack back to level 0 whenever an event in the undesired path occurs. Thus, if RESTART = X, the occurrence of the undesired path (A-X-Y-D) will be detected and the trigger stack automatically restarts at level 0 as if a COLLECT had occurred. Then, when path A-B-C-D occurs, the analyzer will be ready and a triggering sequence will go to completion.

3.4.33 Restart*

RESTART field defaults to OFF. Pressing SELECT key establishes a 48-bit word group in accordance with specified display format, plus an 8-bit qualifier group. If this RESTART word is encountered, it causes trigger stack (described above) to return to level 0.

Pressing SELECT key again causes a bar (NOT indicator) to appear across top of RESTART word. This RESTART condition means that the analyzer returns to the top of trigger stack (level 0) when anything other than the RESTART word is encountered.

Access RESTART field by pressing the T and PREVIOUS keys. Then press SELECT key

* A RESTART word of all Xs is not the same as OFF, and causes analyzer to continually reset trigger stack to zero and never collect data (unless TRIGGER words are also all Xs).

(notice that RESTART word has the same mixed format as trigger words). Enter value 0080 for RESTART word (see Figure 3-19).

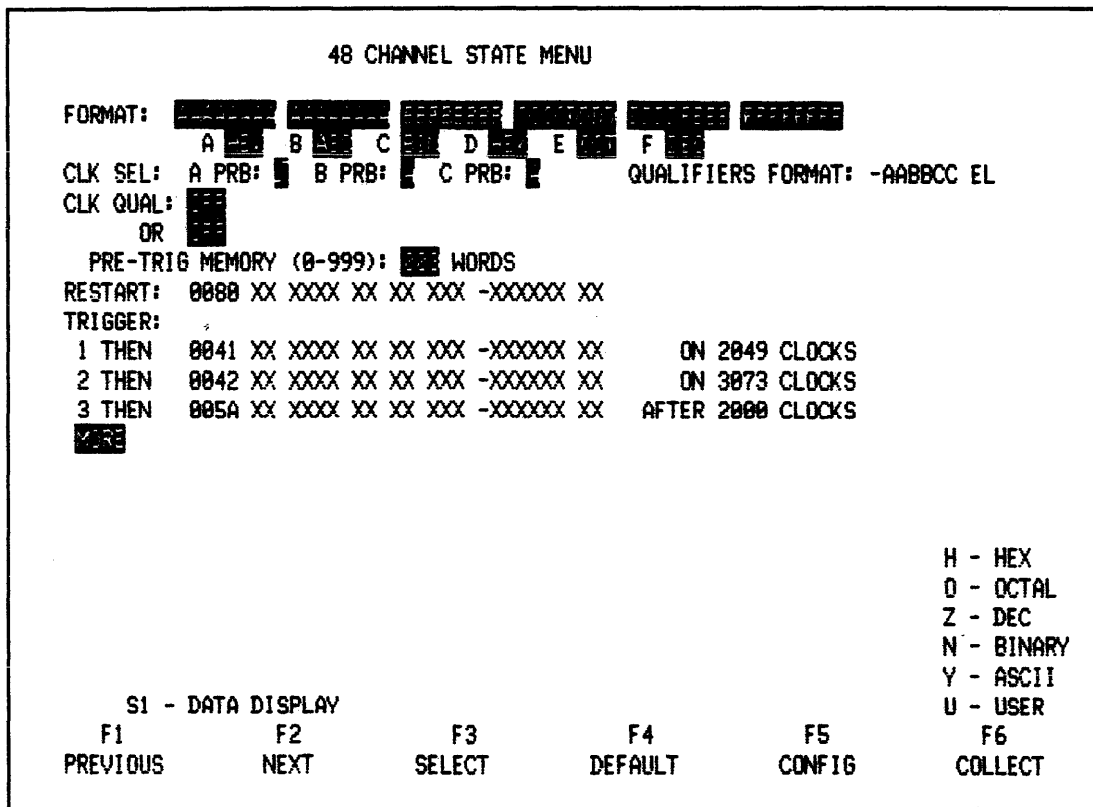

Figure 3-19. State Menu with RESTART Word 0080

3.4.34 Collect

To test restart feature, create an “apparent” branch in the test card’s counter sequence. To do this, short out pad 7 (MSB) on A side of test counter. This causes counter output sequence to consist of 128 counts (0000-007F) instead of 256 counts (0000- 00FF). With pad 7 shorted, press COLLECT. Since RESTART word 0080 never occurs, trigger sequence goes to completion. Now press COLLECT again and remove short before level 3 is reached. Notice that stack returns to level 0 (flashing) because RESTART word 0080 is permitted to occur (see Figure 3-20). Again short out pad 7 and watch the trigger sequence go to completion. Remove short.

```

MAIN.   TRIG 005AFFFFFFFF
        +001 005BFFFFFFFF
LOC: RESTART +002 005CFFFFFFFF
        +003 005DFFFFFFFF
SIG: C077 +004 005EFFFFFFFF
      D8D3 +005 005FFFFFFFFF
      D8D3 +006 0060FFFFFFFF
        +007 0061FFFFFFFF
        +008 0062FFFFFFFF
        +009 0063FFFFFFFF
        +010 0064FFFFFFFF
        +011 0065FFFFFFFF
        +012 0066FFFFFFFF
        +013 0067FFFFFFFF
        +014 0068FFFFFFFF
        +015 0069FFFFFFFF
        +016 006AFFFFFFFF
        +017 006BFFFFFFFF
        +018 006CFFFFFFFF
        +019 006DFFFFFFFF
STATE: STACK LEVEL 0

        F1      F2      F3      F4      F5      F6
SCRL DWN  SCRL UP  LOCATE  SRCH WRD  CONFIG  COLLECT

```

Figure 3-20. Occurrence of 0080 (RESTART) Causes Trigger Stack to Reset to Level 0

3.4.35 Restart

Return to RESTART field and press SELECT key to activate RESTART mode. Like the RESTART word which forces stack back to level 0, the occurrence of any data pattern not matching the RESTART word forces stack back to level 0. Press SELECT key to turn RESTART off.

3.4.36 External Trigger Qualifiers

The 8-bit external qualifier field corresponds to header: -AABBCC EL, at upper right of CRT. The two A bits correspond to a pair of external qualifier lines (Q1 and Q2) coming in through pins 33 and 20 in A probe; likewise, two B bits and C bits correspond to qualifier lines on B and C probes.

E bit corresponds to an additional external qualifier line coming in through EXTERNAL INPUT BNC connector (at rear of analyzer).

L bit corresponds to the this BNC connector. It corresponds to an internal connection to timing analyzer or waveform recorder.

3.4.37 Trigger Qualifiers

Notice that each trigger level or RESTART word can also be set up to require the occurrence of external trigger qualifier events: -AABBCC EL. They act as enabling signals to incoming trigger words. Thus, if level 1 were set up as follows:

0041 X X XXXX XX -1XXXXX 1X,

then A probe qualifier on pin 33 must be high (1) and external BNC input on the rear panel must also be high (1) when 0041 occurs; otherwise, the analyzer will not advance to level 1 from level 0 (do not actually change trigger qualifier from all Xs).

L bit is another trigger qualifier which links any stack level to the successful triggering of timing or waveform analyzers or another analyzer connected to LINK BNC on back panel (use of L bit is discussed in more detail later). In microprocessor applications, for example, trigger qualifiers can control triggering by using signals that are generally not on the address bus or data bus, or are not required in data collection. As such, they can be considered as extra channels that are not displayed. Thus, for the NPC-800C, a 56-bit-wide trigger word can be specified (48 data channels plus 8 trigger qualifiers).

Move cursor to TRIGGER level and press SELECT twice.

3.4.38 Clock Qualification

Move cursor to CLK QUAL field by pressing S1 then C (see Figure 3-21).

3.4.39 First Clock Qualifier

This is the first of two OR'ed clock qualification conditions that can be imposed by the state analyzer on data collection. This field normally defaults to OFF. With OFF cursor flashing, pressing SELECT (F3) key activates this field. Qualifier field consists of 48-bit word (for data qualified clocking), followed by six A, B, and C probe qualifier inputs (AABBCC), plus E bit described above. This 55-bit word automatically is grouped in accordance with the predefined display format. To set up the qualifier field, simply enter in HEX, OCT, DEC, or BIN digits as required. If a digit entered is out-of-range for format used, software automatically "drops off" higher-order bits down to the number of bits allowed in the field. Also, values must be within the range of the selected base, such as 0-7 for an octal digit; otherwise an error message appears.

Single formats can be used in this field independent of the format used for RESTART word, TRIGGER word, or display. Simply press HEX, OCT, etc. Then key for single format of your choice. To recover original display format, press USER key, U.

NOTE

To enter an ASCII character, the two-digit HEX equivalent must be used. The six probe qualifier bits can be entered only as 0, 1, or X; E bit can only take on a 1 or X value.

3.4.40 Second Clock Qualifier

Next line is second OR'ed clock qualifier. It is set up in exactly the same way as first qualifier.

3.4.41 Clock Qualifier

Internal clock qualifier field is used to limit collection of data to a certain range of address or data words. Without this qualifier, the NPC-800C would simply collect sequential counter data from the test card. Starting with trigger word 0040, a nonqualified data collection would consist of 0041, 0042,... 0050, 0051, 0052...etc. But suppose you wished to exclude from the collection all address words that **did not** begin with 004. In other words, data collection is to

contain address words between 0040 and 004F only. To test this, set clock qualifier word corresponding to A probe input data to 004X (rest of this field should remain all Xs (see Figure 3-21).

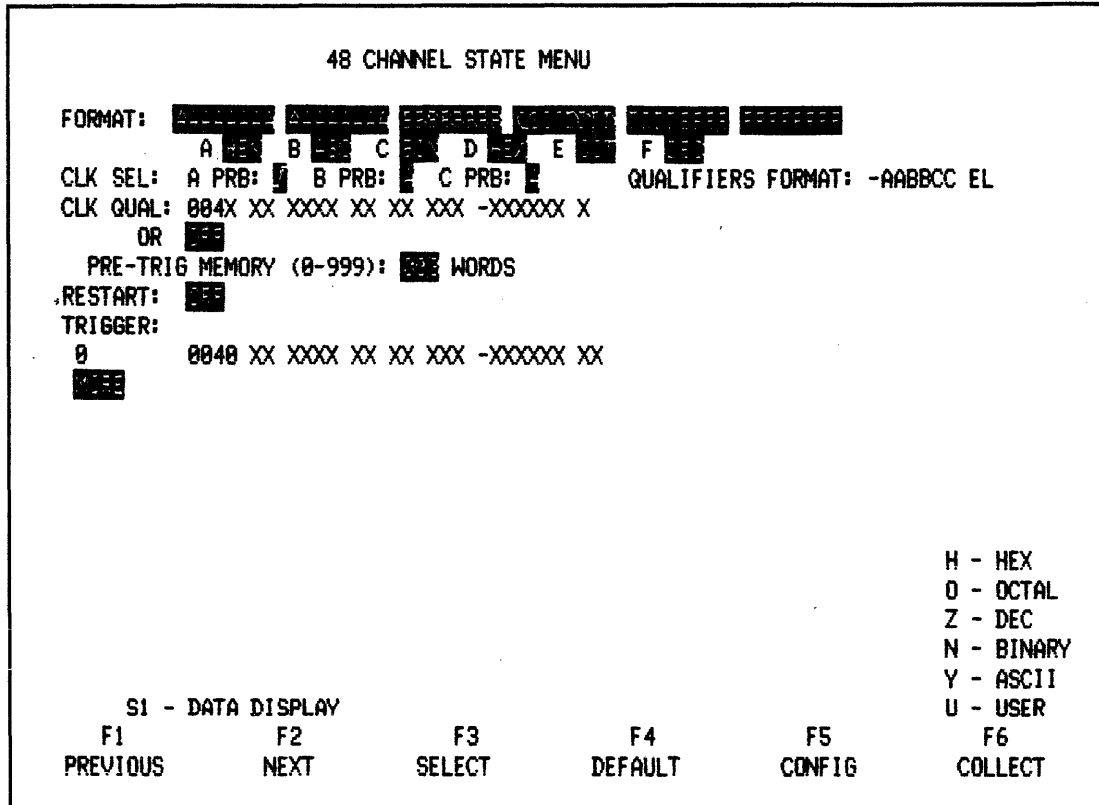

Figure 3-21. Setting Up Internal Clock Qualifier Field

3.4.42 Collect

Press COLLECT to collect qualified data. Notice that COLLECTION STATUS line reads STATE: TRIGGERED and provides a real-time count as 1000-word state memory fills up. Also notice that word +016 is now 0040, instead of 0050. Scroll data collection upward. Only addresses over the range 0040-004F are in data collection (see Figure 3-22).

MAIN	TRIG	00	40	FF	FF	FF	FF
	+001	00	41	FF	FF	FF	FF
LOC: TRIG	+002	00	42	FF	FF	FF	FF
	+003	00	43	FF	FF	FF	FF
SIG: B90C	+004	00	44	FF	FF	FF	FF
	D2CD	+005	00	45	FF	FF	FF
	D2CD	+006	00	46	FF	FF	FF
	+007	00	47	FF	FF	FF	FF
	+008	00	48	FF	FF	FF	FF
	+009	00	49	FF	FF	FF	FF
	+010	00	4A	FF	FF	FF	FF
	+011	00	4B	FF	FF	FF	FF
	+012	00	4C	FF	FF	FF	FF
	+013	00	4D	FF	FF	FF	FF
	+014	00	4E	FF	FF	FF	FF
	+015	00	4F	FF	FF	FF	FF
	+016	00	40	FF	FF	FF	FF
	+017	00	41	FF	FF	FF	FF
	+018	00	42	FF	FF	FF	FF
	+019	00	43	FF	FF	FF	FF
	+020	00	44	FF	FF	FF	FF
	+021	00	45	FF	FF	FF	FF
	+022	00	46	FF	FF	FF	FF
	+023	00	47	FF	FF	FF	FF

Figure 3-22. Qualified Data Collection Containing Addresses From 0040 Through 004F Only

3.4.43 Clock Select

Press C and PREVIOUS to move cursor to CLK SEL field.

This field selects polarity of A, B, and C clocks coming into A, B, and C probes, respectively. If multiphase clocking is not required, B and C probe clocks should be set to A (same as A probe clock); otherwise, use appropriate clock edge, (F3) for positive, (F4) for negative.

Data are stored into each memory board on the corresponding clock edge; however, C clock must occur last. Because the test card is so simple, you can try multiphase clocking on your hardware.

3.4.44 Autocollect

Press CTRL and C simultaneously to activate an automatically repeating data collection mode. Press any ASCII key to stop.

AUTOCOLLECT mode is useful to view a small portion of data collected while making changes to circuit under test. An example is varying the power supply voltage.

3.5 TIMING ANALYSIS

3.5.1 Timing Analysis Examples

The timing analyzer is separate from the state analyzer that has just been reviewed. It records

data in a separate memory and uses its own menu for setup. The following section reviews its functions and how they are used.

3.5.2 Setup

Before starting this test, connect the two A and B Model 81 timing probes to the NPC-800. Then connect these probes to the test card's A and B outputs, respectively (Leave state probes plugged into NPC-800).

3.5.3 Initialize

Unless you have just turned on the power to begin this section, before continuing, press RESET key for two seconds to initialize analyzer.

3.5.4 16-Channel Timing Menu / 1000 Words, 200 MHz Max.

1. To Call Menu
 - a. Press CONFIG or RESET key.
 - b. Press soft-key labeled SEL DOWN or SEL UP as appropriate to move cursor to 16-CHANNEL TIMING position.
 - c. Press F1 to select TIMING menu.
 - d. Place cursor in CLOCK field, at top of menu.

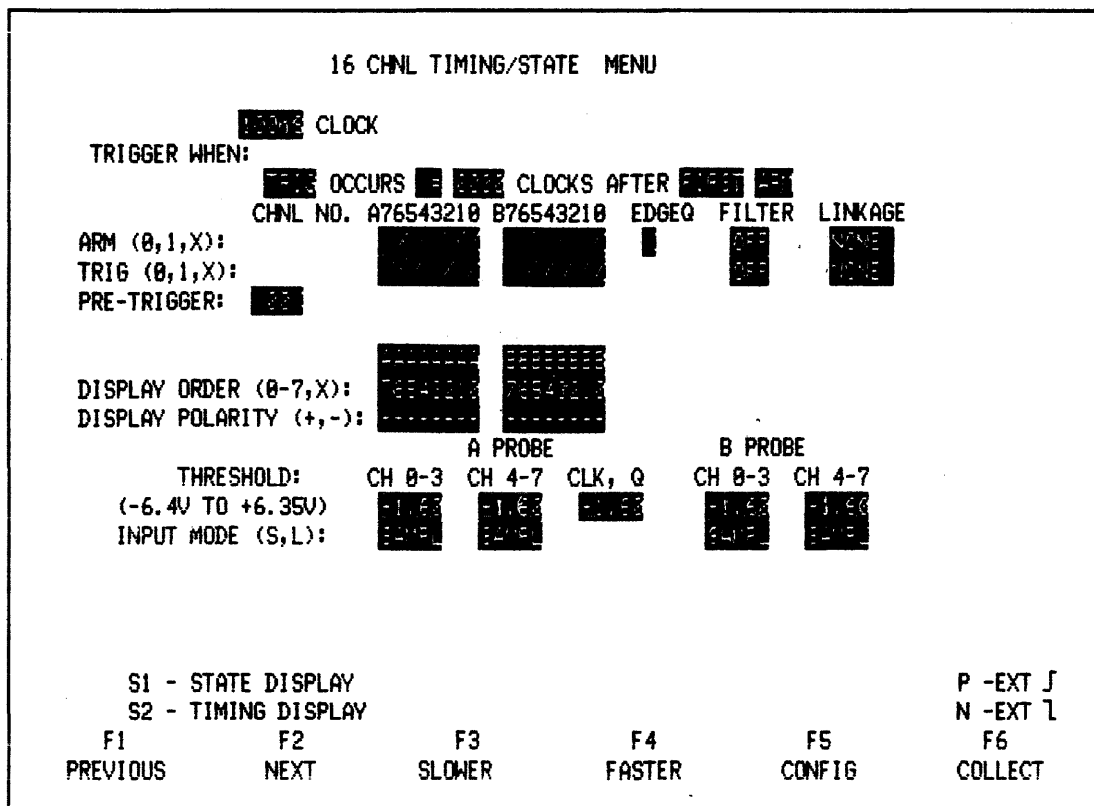

Figure 3-23. 16-Channel Timing Menu

2. Explanation of Clock Select Menu

The CLOCK SELECT field displays the sampling interval (internal clock) or clock polarity and qualifier (external clock). Clock speed is selected using SLOWER (F3) and FASTER (F4) keys. External clock polarity is selected by P, for positive edge, or N, for negative edge. If an external clock is selected, CLOCK QUALIFIER field is displayed, allowing selection of 1, 0, or X for the external clock qualifier bit.

3.5.5 Collection

Leave all menu parameters set at their default values (see Figure 3-23). Press COLLECT (F6) key. Notice a brief status message TRIGGERED that appears in lower left corner of CRT screen. When a timing data collection is complete, the message "DONE" is displayed briefly in its place, and the screen fills with timing diagram display.

3.5.6 Clock Speed

Data display shows sampling rate (clocking speed) in top left-hand corner. Default value of 100 nanoseconds is very fast for the test card's CMOS circuit; consequently little activity is seen on timing diagram. To return to menu and enter clock field press C. Use F3 key (slower) to set sampling rate to 100 microseconds. Press F6 (COLLECT) to collect data. Resulting collection is shown in Figure 3-25. Notice high and low transitions shown on most lines and cross hatching on lines A1 and A2 (This will be discussed later in "Magnification").

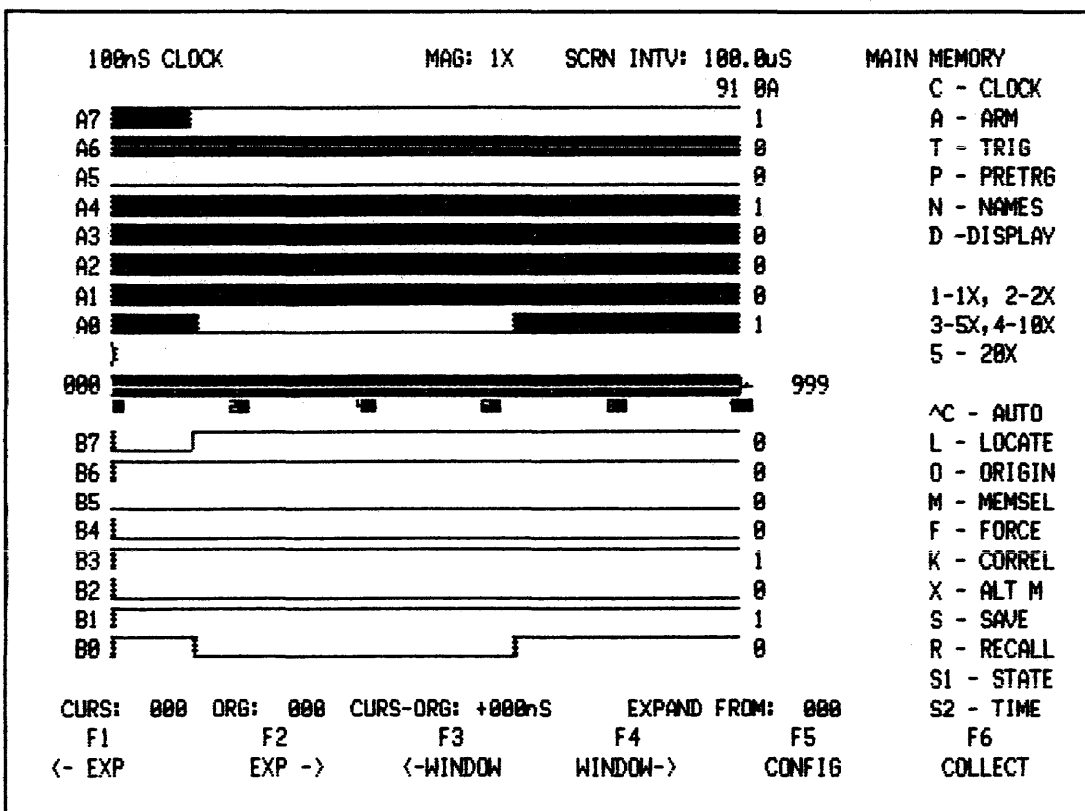

Figure 3-24. Typical Timing Diagram Display

3.5.7 Timing Diagrams

The NPC-800 displays all 16 channels of timing data simultaneously, but in two groups of 8. The cursor is used to measure time between events. The value of corresponding data in binary at current cursor location is displayed at right end of each timing trace. Notice that NPC-800 provides a unique "shaded" display for those timing diagrams whose transitions are occurring too close together to be resolved at lower screen magnifications. This feature reduces the possibility of making erroneous visual time measurements. Shaded areas are always resolved into discrete lines at X10 or X20 magnification factors.

3.5.8 User Prompts

During this session we frequently move back into various menu fields from the data display. To make this easier and faster, as in the state analyzer, pressing LABELS key displays a menu of valid keystrokes. While in the menu, if invalid key or the ? key is pressed, the analyzer prompts you with a selection of proper keystrokes.

3.5.9 Labels

Prompting messages can be accessed (after a data collection is displayed) by pressing LABELS key. It identifies all direct entry functions (see Figure 3-25).

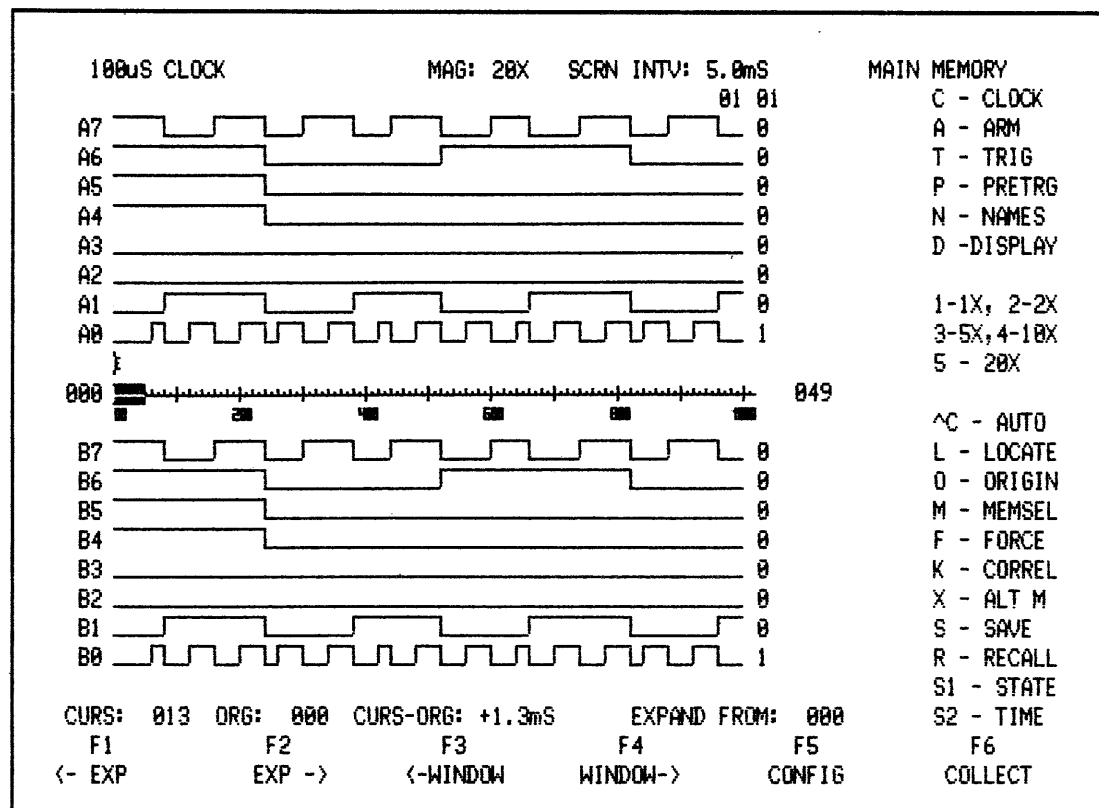

Figure 3-25. Timing Diagram LABELS Function

C-CLOCK A-ARM T-TRIG P-PRETRIG D-DISPLAY	With cursor located in particular field selected by each key, these keys call the TIMING menu. For example, T places cursor in menu's TRIGGER field. Other fields can then be accessed by using PREVIOUS or NEXT. Also, S2 can be pressed again to call data.
N-NAMES	N key places a cursor at right of timing diagram display for generation of an 8-character alphanumeric label for each channel. These labels are defined by the user to identify and document displayed signals. Pressing ESC key terminates NAME mode.
1-1X 2-2X 3-5X 4-10X 5-20X	Numeric keys 1, 2, 3, 4, and 5 expand timing (and waveform) displays by indicated factor. Expansion occurs from right of current position of expansion cursor, represented on screen by symbol E. When expansion occurs, expansion cursor, normally is positioned to the left of screen. Exact position of expansion cursor is indicated on screen in EXPAND FROM field.
L-LOCATE (CURSOR)	L is used to bring timing cursor rapidly onto left-hand edge of screen. This is useful when cursor's present location is away from present window of data being viewed.
O-ORIGIN	O is used to simplify time measurements with the cursor. Pressing this key causes current position of cursor to become the ORIGIN. In waveform mode, voltage at current cursor position also becomes ORIGIN value. Moving cursor from this position then causes differences in time (and voltage) between cursor and origin values to be displayed.
C - AUTO	Control-C causes analyzer to collect and display data continuously.
M-MEMSEL	M, MEMSEL, selects MAIN or AUXILIARY memory for display.
F-FORCE	If COLLECT key has been pressed, but triggering conditions have not been met (or if collection is only partially complete), F, the FORCE DISPLAY key, stops data collection process and causes captured data to be displayed. Last data word collected is automatically defined as trigger point. Pressing FORCE DISPLAY key allows prior 999 words to be viewed, regardless of pretrigger field setting.
K-CORREL	K is used to calculate correlation (figure of merit) between current data collection in main memory and reference data in auxiliary memory. Computation is performed independently for each active channel. Total bit-for-bit correspondence results in a correlation of 1.000 being displayed. A one-bit difference, for example, reduces correlation to 0.999 (For a correlation example, see Section 3.5.31).

NOTE

*When K key is pressed, correlation values replace timing diagram names.
Press S2 to return the names.*

X-ALT M	X key causes display to alternate automatically between MAIN and AUX.
S-SAVE*	After a data collection has been made, pressing S key saves main memory contents into auxiliary memory. Included with saved data is the set of menu parameters and test codes used to obtain data collection.
R-RECALL*	Pressing R key recalls menu information and data stored in auxiliary memory using SAVE key. This function allows a previous test to be repeated without having to re-enter parameters.

Note

Pressing RECALL key causes current menu parameters to be lost.

S1-STATE	S1 key allows user to select state equivalent of timing diagram or analog waveform displays. Pressing S1 again calls timing display.
S2-TIME	S2 key returns timing display.

3.5.10 Magnification

Using the 2 to 5 numeric keys indicated in the DISPLAY MENU, try magnification factors between 2X to 20X. After each higher magnification key is pressed, the inverse video indicator at the center of the screen reduces proportionately in size. This indicator shows location and amount of timing data currently being displayed relative to entire 1000-word data collection. At 20X magnification, notice that inverse video indicator is only five percent of its original (1X) size and that the screen is now displaying timing data between memory locations 000 and 099 (see Figure 3-26).

3.5.11 Trigger Location

Horizontal inverse video graticule at middle of display represents entire 1000 samples in memory. Notice that small 00 indicator at left end of graticule is intensified. This indicates 00 percent pretrigger value set in previously. With 00 percent pretrigger, the first word in data collection always is the trigger word.

Numbers at left and right-hand sides of graticule indicate boundary values of displayed data.

3.5.12 -WINDOW, WINDOW- (F3, F4)

The -WINDOW and WINDOW- keys are used to select a specific portion of the data collection currently being displayed. This window, and its position in data memory, are shown by the inverse video portion of the graticule below the waveforms on the screen.

NOTE

For any expansion factor other than X1, all data memory cannot be displayed at one time.

For these larger expansion factors, pressing either WINDOW key steps or sweeps (using REPEAT) window so that entire data collection can be viewed. Moving window to right, for example, causes displayed data to move from right to left.

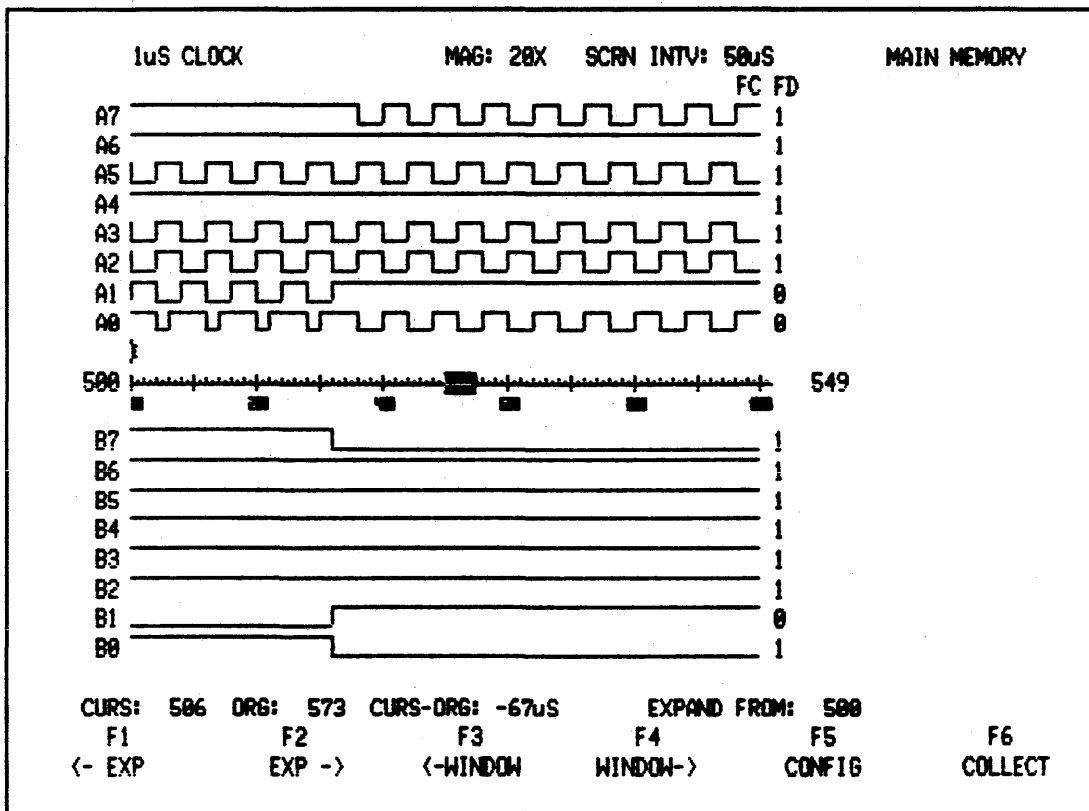

Figure 3-26. Magnified Data Display X20 (Locations 500 to 549)

3.5.13 Expand (E)

Press X2 to obtain timing data. Notice expansion cursor E, which is positioned just above center graticule, used to define the position from which display will be expanded. Press F2 to sweep symbol toward center of display at location 500, (see Figure 3-27). Use F1 to step back if you overshoot. Press Magnification Keys 1-5 to expand picture as required.

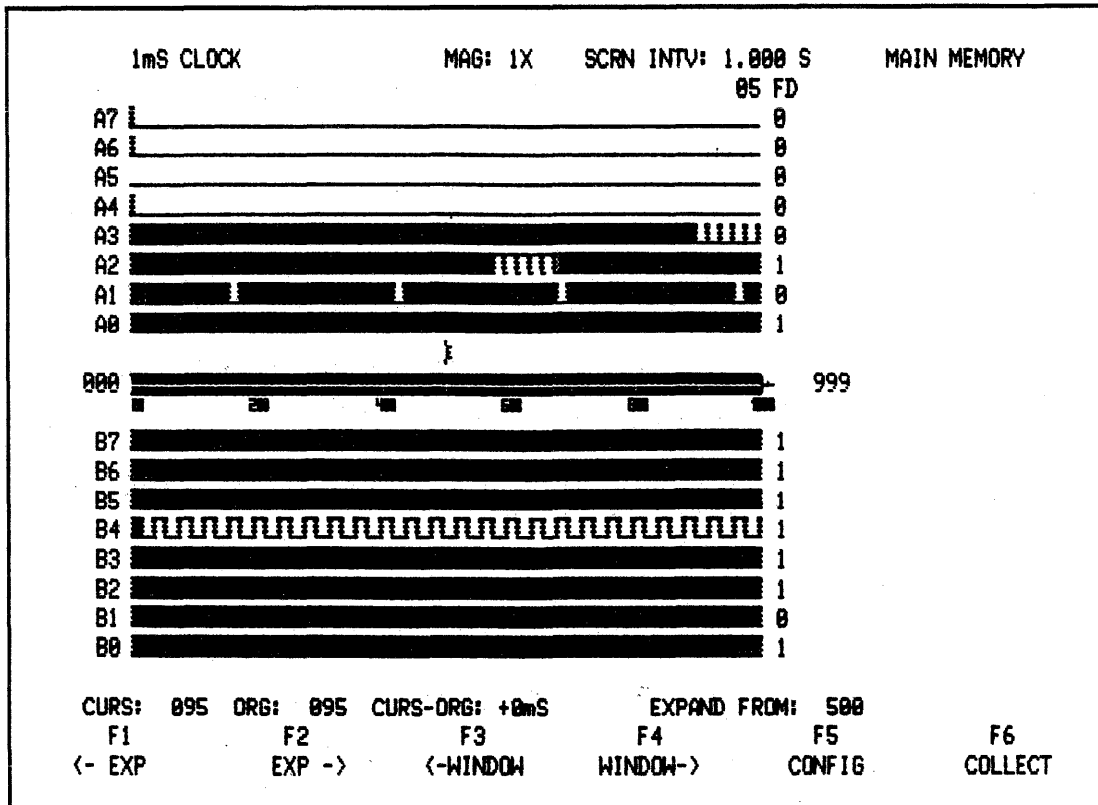

Figure 3-27. Timing Display with Expansion Symbol, E, At Location 500

3.5.14 Expansion Indicator (E)

By pressing EXPAND keys -EXP or EXP-, this indicator can be moved anywhere within the screen. By pressing EXPAND keys -EXP or EXP-. It is used to locate an area in the current screen that requires additional magnification. Expansion is always to right of indicator.

3.5.15 -EXP, EXP- (F1, F2)

The -EXP and EXP- keys move expansion cursor, E, back and forth on the screen. The expansion cursor cannot be moved off the screen.

3.5.16 Cursor

To set cursor quickly (currently at 000) to left side of screen, simply press the L (LOCATE CURSOR) key as indicated in LABELS menu. Bring cursor to approximate center of CRT by pressing SPACE BAR key (Overshooting can be remedied by pressing BACKSPACE key)

3.5.17 Cursor Right, Cursor Left

SPACE BAR and BACK SPACE keys step timing cursor right or left, respectively, through data collection.

As cursor moves, its current position is indicated at screen's lower left. Cursor measures time between events in data collection and can be used in conjunction with the ORIGIN function.

Even if cursor is off-screen, its position is still indicated correctly. Also, the binary value corresponding to the state of each input line at the cursor appears at right-hand-side of screen. Whether they are displayed or not, associated hexadecimal value corresponds to all channels in memory. Binary and hexadecimal values change when display order is modified in the menu

3.5.18 Time Measurements Using Cursor and Origin (O)

In this step, you measure the relative time between edges in two channels. Visually select an edge (rising or falling) in channel B2 and another edge (later in time) in channel B6. Step cursor so that it aligns with selected edge in channel B2. Notice value of cursor position indicator at lower left of screen. Now press letter O to reset origin from 000 to current cursor location. The CURS-ORG indicator should now read zero units of time (When external clock is used, indicator reads +0CS, where CS stands for clock samples). Next, step cursor to selected edge on channel B6. CURS-ORG indicator now directly reads time between these two edges (Figure 3-28 shows one example of using this measurement procedure).

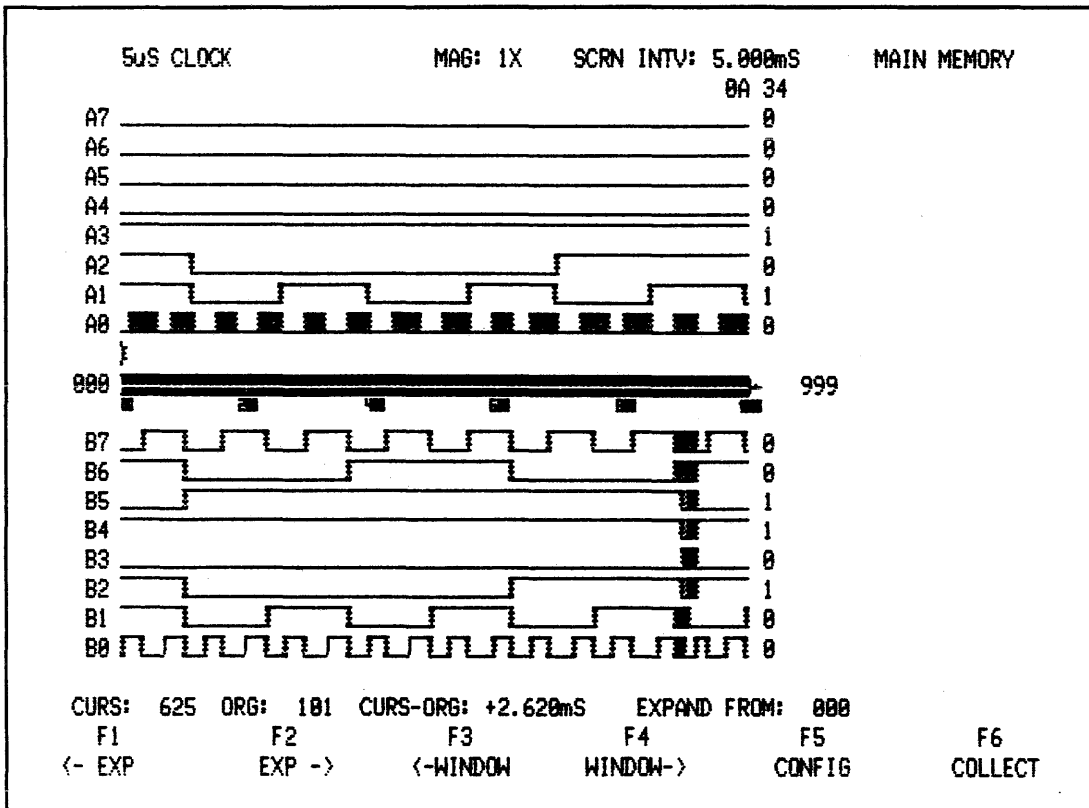

Figure 3-28. Measuring Relationship Between Timing Data Edges
(Your example may differ)

3.5.19 Timing Display Manipulation

The NPC-800 allows you to change both the order in which timing diagrams are displayed and their polarity.

3.5.20 Display Order (0-7, X)

Access DISPLAY ORDER field by pressing D key. Labels A and B correspond to 8-bit data groups coming through A and B probes. X blanks out a line, and numbers 0-7, entered in any order (or even repeated), set up display order within probe group. To illustrate timing display flexibility of NPC-800, set in following display order for eight most significant channels: B4 - A0 - A6 - B7 - B0 - X - B4 - A2. Use NEXT key to step down to DISPLAY POLARITY field. Then set in following display polarity: - + + + - + + + (see Figure 3-29).

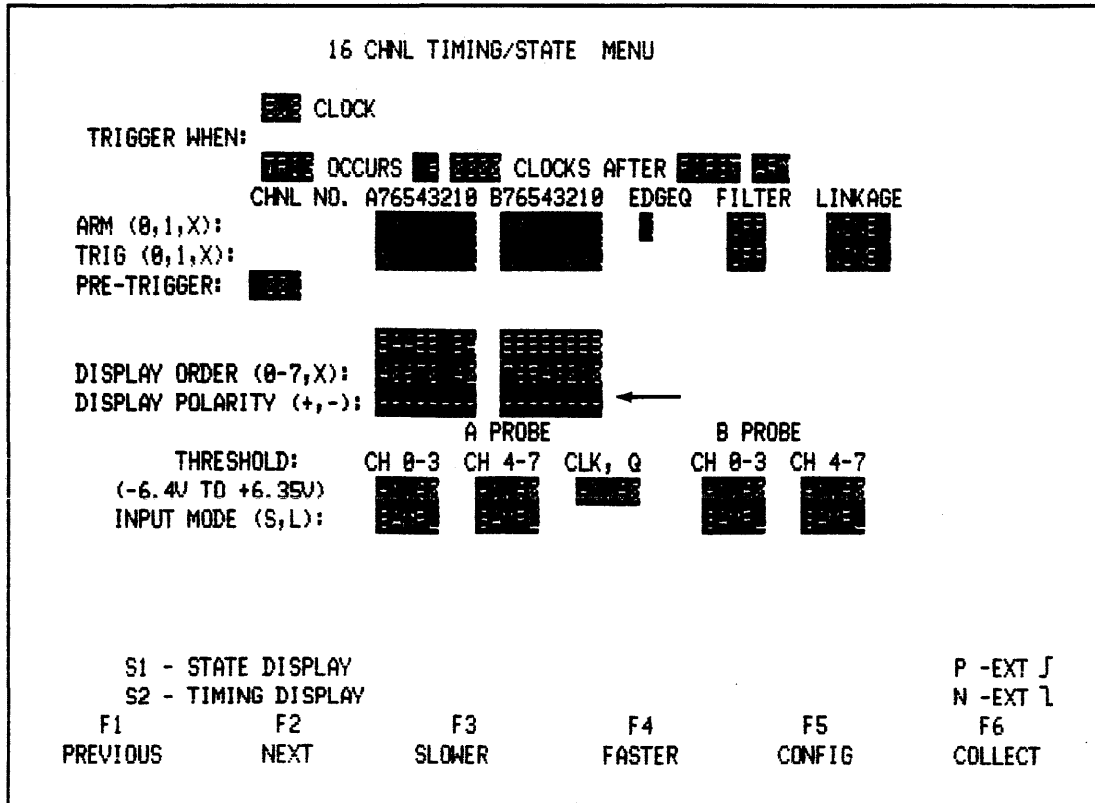

Figure 3-29. Menu showing NPC-800's Timing Display Flexibility.

3.5.21 Display Polarity (+, -)

Use of + or - keys here displays respectively, a TRUE or COMPLEMENTED timing diagram.

3.5.22 S2 4 (10X)

Now press S2 and 4 (for 10X) keys. At 10X magnification, the timing diagram is similar to Figure 3-30. The NPC-800 permits the display of any mix of inverted and noninverted channels. Any channel can be blanked out and repeated. In Figure 3-30, B4 is inverted at top of CRT and is adjacent to A0. Near center of display, B4 appears noninverted and is adjacent to A2.

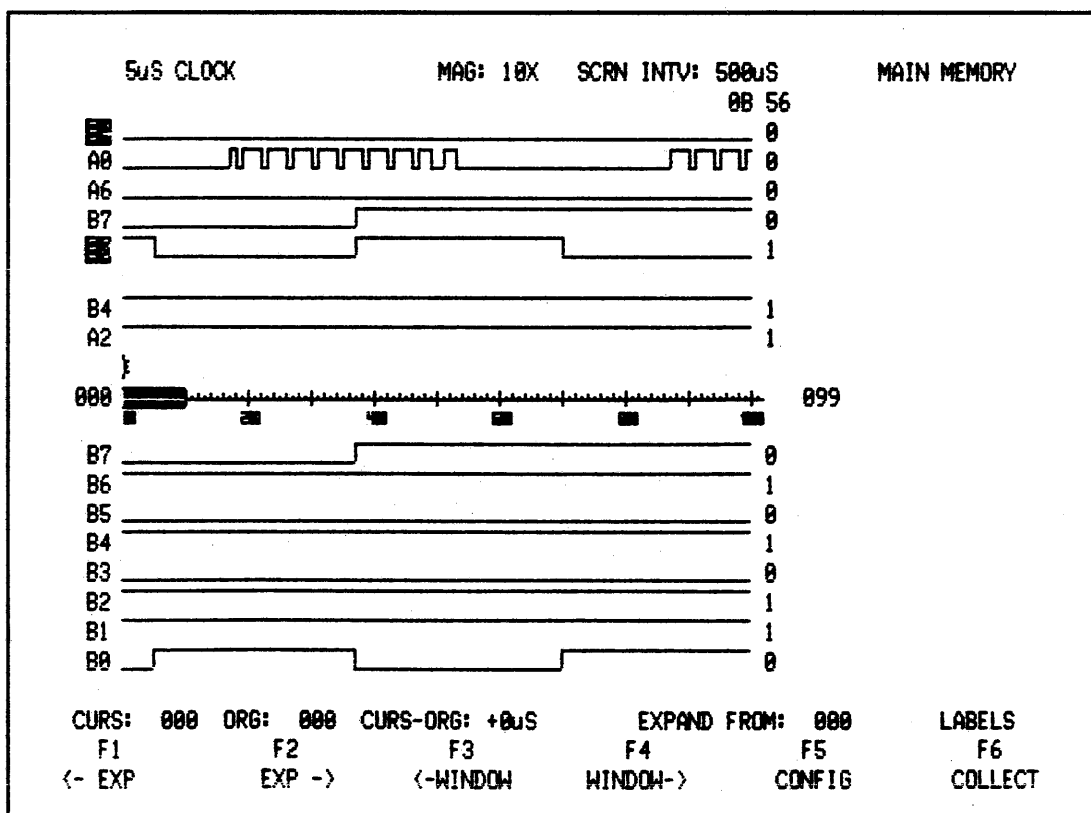

Figure 3-30. NPC-800's Timing Diagram Display Flexibility

Press RESET key to initialize all parameters for next steps. Then select 16-channel timing mode and press COLLECT.

3.5.23 Names

Press N key to activate NAME cursor at upper right-hand side of screen. Each channel can have up to eight characters for a name. Enter characters from ASCII keyboard, terminate each line with a CR, and when all required labels have been assigned: press ESC key. To edit labels, use SPACE BAR. To move cursor and type in new entries use BACKSPACE as required (see Figure 3-31).

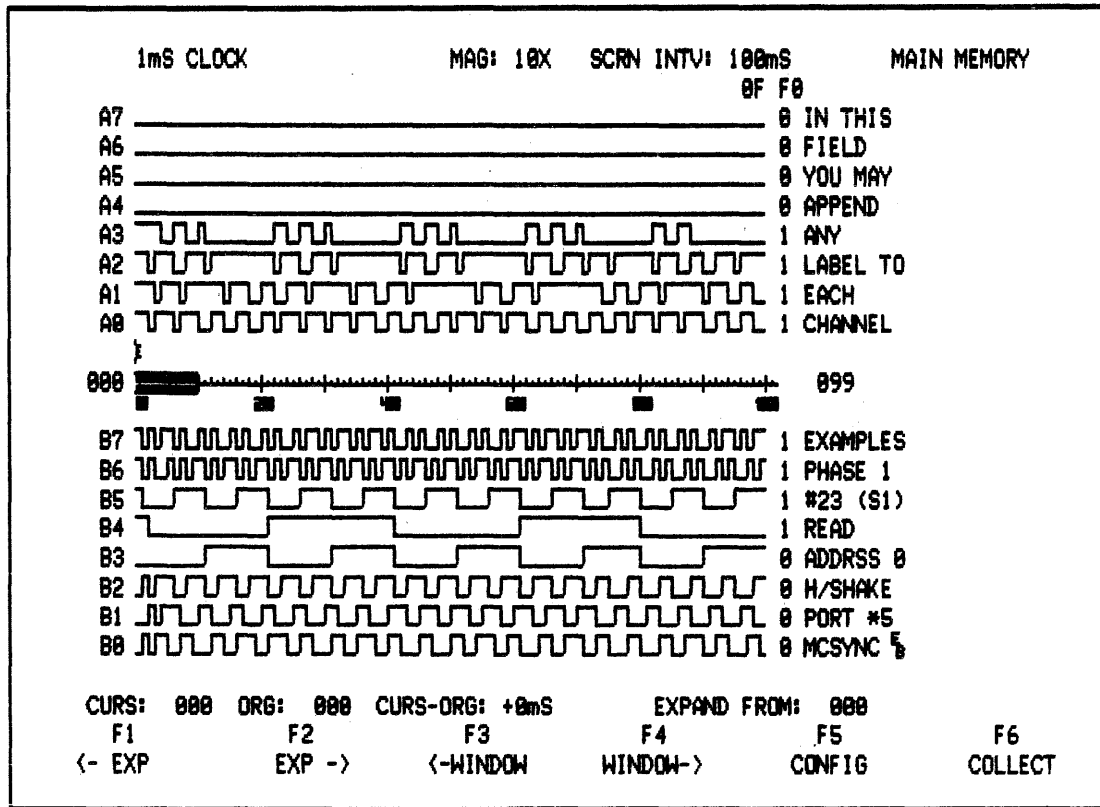

Figure 3-31. Timing Diagram Assignment of Labels (NAMES)

3.5.24 Trigger

To enter a trigger word, return to trigger field in menu by pressing T. ENTER 00001100 XXXXXXXX. Press F6 to collect data.

Press 1 and then L to move cursor to location 000. Binary values at end of each trace should be those of trigger word entered.

3.5.25 Arm and Trig

With 16-CHANNEL TIMING menu on display and cursor at CLOCK field, use SLOWER key to select 2 millisecond clock.

In this example, both levels of triggering are used. Press S2 and A as a quick way to enter ARM field. Then enter: 0-0-0-0-0-0-0-0 plus 0-1-0-0-1-0-0-0, which is (0048) HEX. Use NEXT key to step down to TRIG field and enter: 0-0-0-0-0-0-0-0 plus 1-1-0-0-1-0-0-0, which is (00C8) HEX.

3.5.26 Triggering Modes

Because two levels of triggering have been set up (ARM an TRIG), one of the triggering modes must be used to specify time delay between these levels. Use PREVIOUS key to access TRIGGER MODE field. Press SELECT key to view following major timing trigger mode options:

TRIG OCCURS 0001 CLOCKS AFTER FIRST ARM

TRIG OCCURS BEFORE 0001 ARMS

Within first two major modes, NEXT and SELECT keys can be used to change TRIG to TRIG, = to or = (blank), BEFORE to AFTER, FIRST to LAST, and ARM to ARM.

Set trigger mode to TRIG OCCURS = 0000 CLOCKS AFTER FIRST ARM. Then use NEXT key to step to DELAY field and set in a delay value of 1501. Trigger mode should now read:

TRIG OCCURS = 1501 CLOCKS AFTER FIRST ARM.

3.5.27 Pretrigger

Access PRETRIGGER field by pressing S2 and P keys. Use "soft" key INCR to set this field for 50 percent pretrigger (Figure 3-32 shows timing menu up to this point).

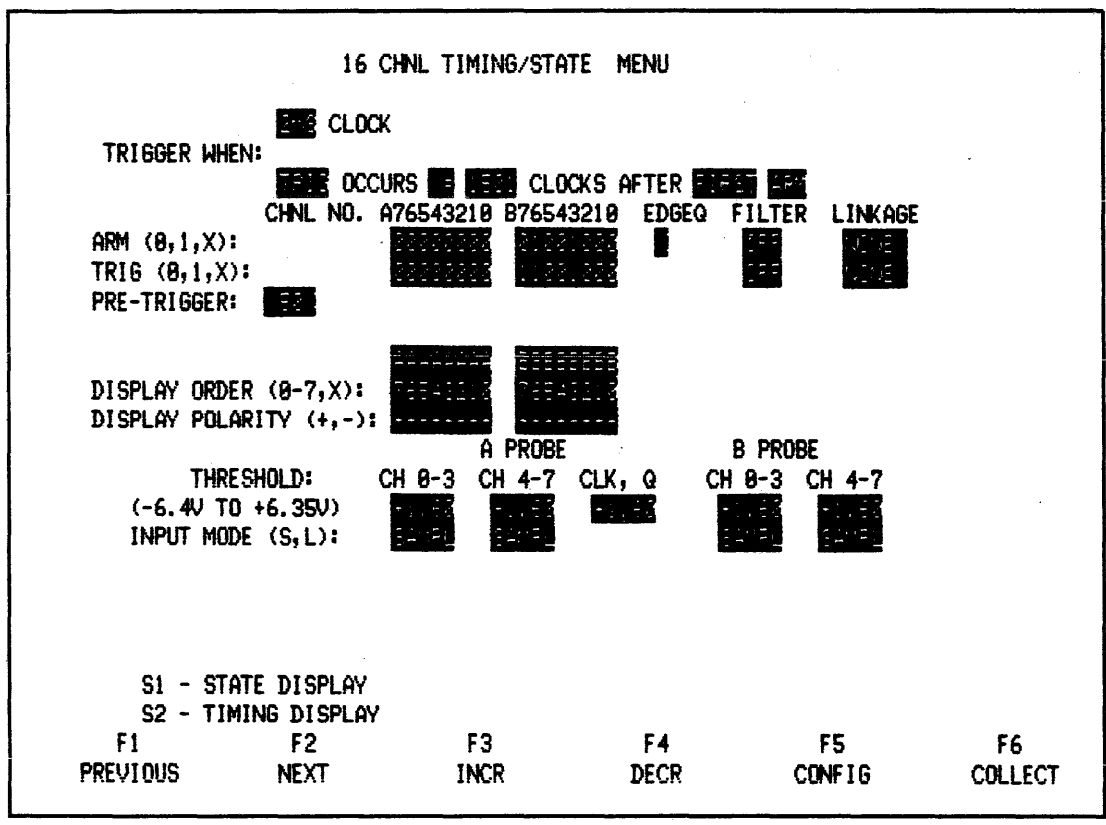

Figure 3-32. Menu Corresponding to This Example (Thus far)

3.5.28 Status Messages

Press COLLECT and wait several seconds. Notice flashing status messages which indicates what the analyzer is doing as it transitions from SAMPLING to ARMED to TRIGGERED to DONE (relatively slow 2 millisecond clock allows these messages to be observed).

3.5.29 Pretrigger Memory

To ensure data collection, the NPC-800 does not require a full amount of pretrigger data be collected before the trigger condition becomes satisfied; the amount of data actually preceding trigger point can be less. However, the amount of data following trigger point is always constant for a given pretrigger value.

3.5.30 Trigger Sequence

With timing diagram displayed (at 1X magnification), locate trigger word, 00000000 11001000 (00C8). Notice that the 500 mark on the inverse video graticule at the center of the CRT is at full intensity. This is the location of the trigger word with 50 percent pretrigger set in. When COLLECT key was pressed, the following sequence of events occurred:

1. SAMPLE (COLLECT DATA AT 2 m INTERVALS)
2. DETECT ARM WORD (0048)
3. START TO COUNT AT LEAST 1501 CLOCKS (3 seconds +)
4. COLLECT PRETRIGGER DATA (500 WORDS PRIOR TO TRIGGER WORD)
5. DETECT TRIG WORD (00C8)
6. COLLECT TRIGGER WORD AND FILL REMAINING MEMORY (TRIGGER WORD PLUS 499 ADDITIONAL WORDS)
7. DISPLAY (MESSAGE DONE)

Display at 1X magnification is shown in Figure 3-33.

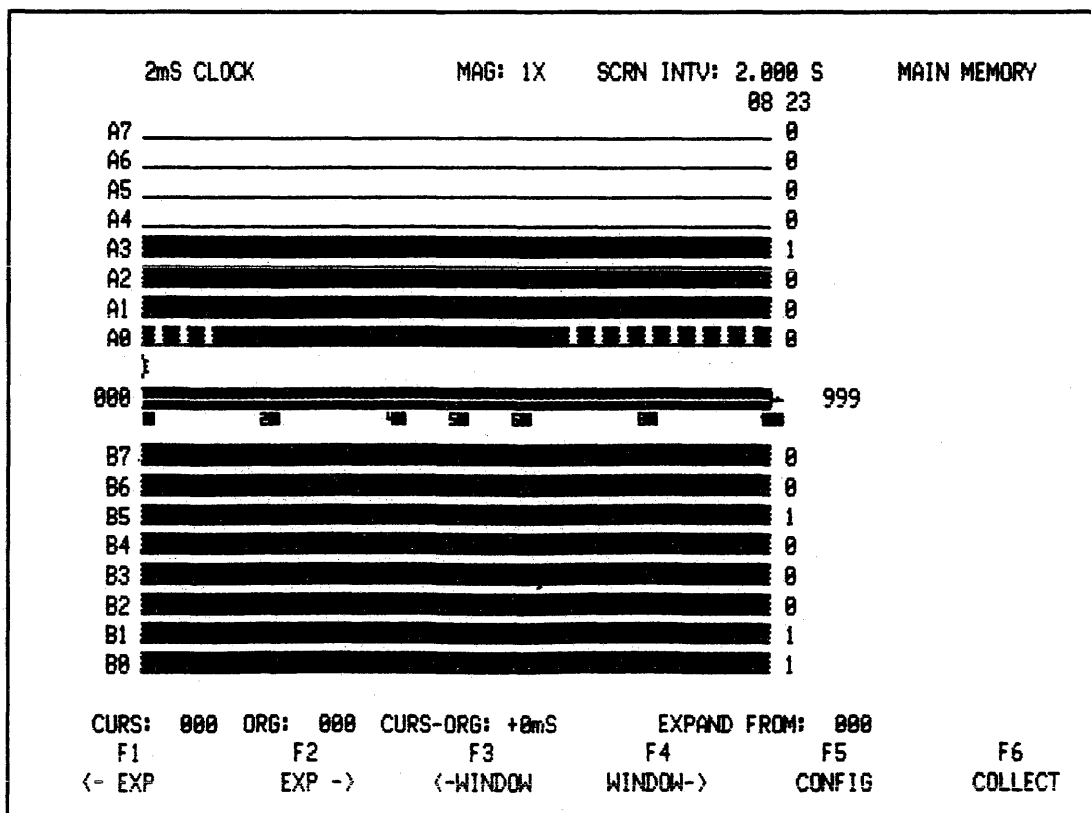

Figure 3-33. Timing Display At 1X Magnification

**3.5.31 Correlation (K)
 Change Clock Speed To 100 Milliseconds**

Press SAVE (S) key and observe flashing SAVED message. Press K (CORREL) key to compare main and auxiliary data. A correlation factor of 1.000 is displayed at right of each channel. This factor means that all 1000 bits associated with each main memory channel compares with the 1000 bits in the corresponding auxiliary memory channel on a bit-for-bit basis (see Figure 3-34). Thus, if a correlation factor for .995 is displayed, it indicates 5 bits out of 1000 were different.

NOTE

When K key is pressed, correlation factors replace NAMES. To restore NAMES, press S2.

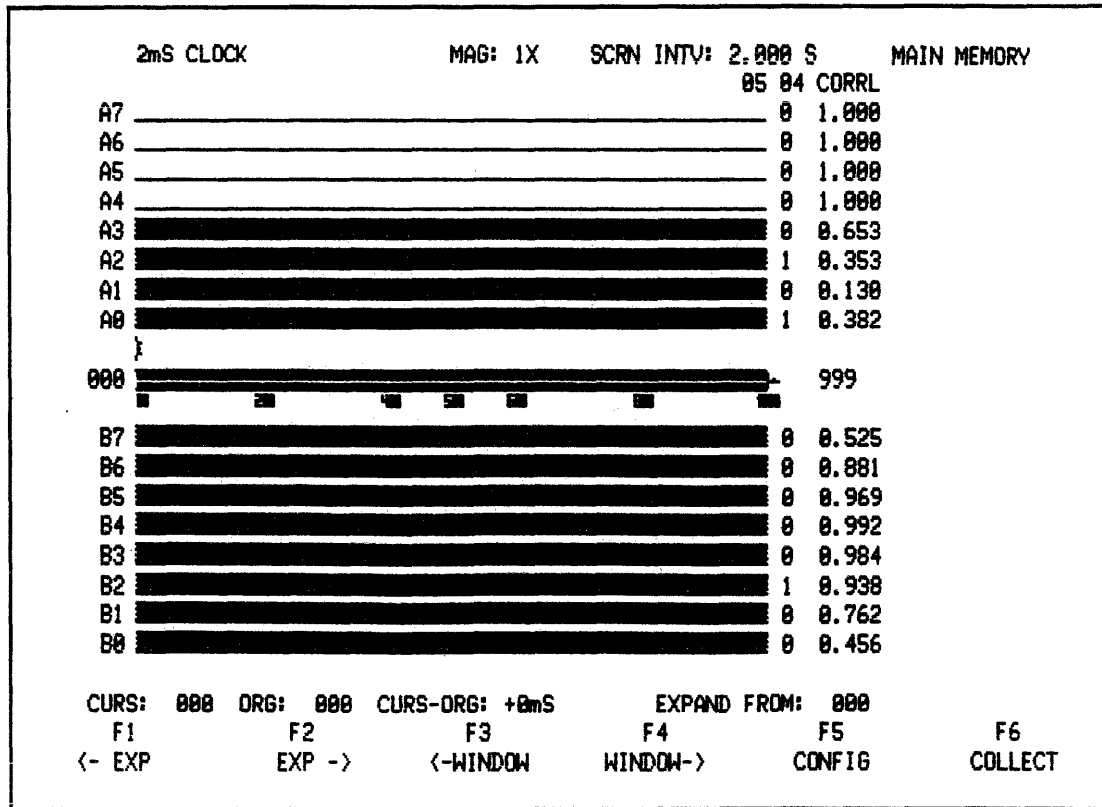

Figure 3-34. A Correlation Factor of 1.000 Means That Data In a Main Memory Channel Precisely Matches Data In Corresponding Auxillary Memory Channel

Now short out pad labeled 5 on B side of demo card. While holding short in place, press COLLECT. When collection is complete, remove short. To see which channel was affected by short, again press K. Notice that the correlation factor for channel B5 is significantly lower than 1.000.

3.5.32 Main/Aux Memory Compare (X)

To view actual effect of short on channel B5, press X (ALT MEMORY) key. As shown in Figure 3-35, channel B5 should cycle between a 1 and a 0. Return to X1 magnification by pressing 1 key.

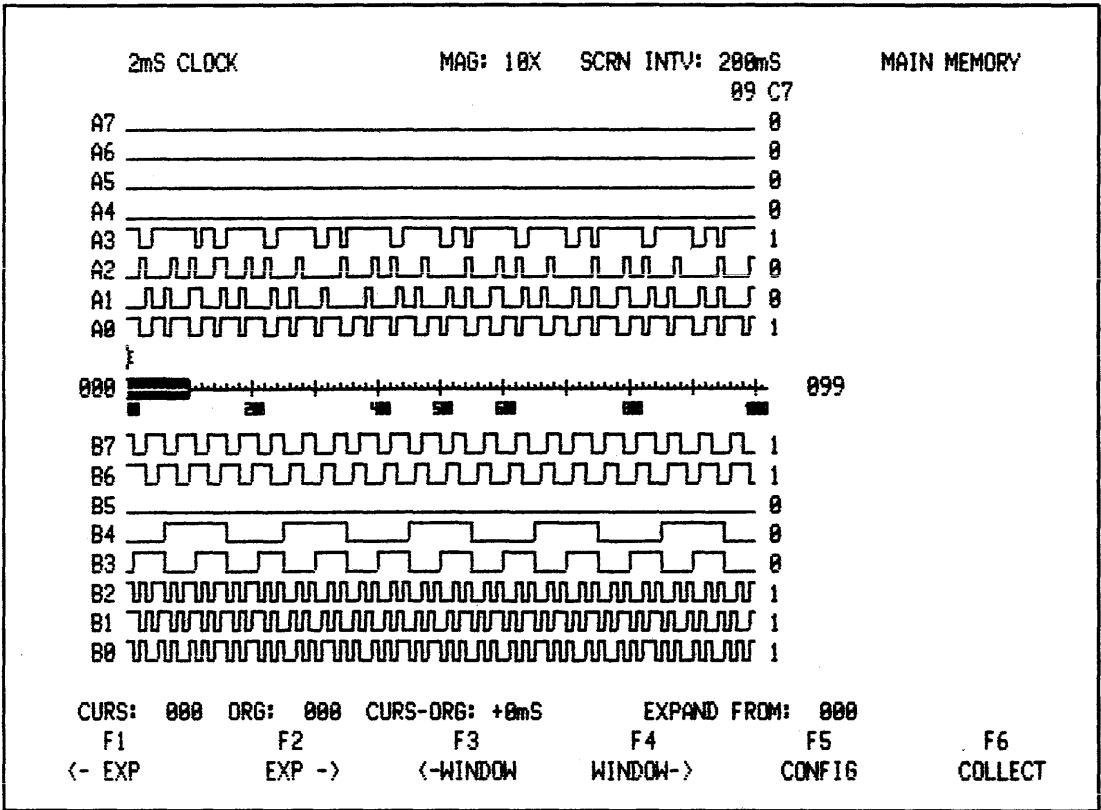

Figure 3-35. MEMORY SELECT Key Used to Observe Effect of Short In Channel B5. (A) auxiliary memory. (B) main memory. Alternate between two by pressing X key.

3.5.33 Auto Collect

To activate an automatically repeating data collection mode, press CTRL and C simultaneously. Press any ASCII key to stop.

This mode is useful for observing effects to device under test changes, such as those caused by power supply voltages.

3.5.34 Edge Qualification

In the ARM field, combinational logic values (0,1,X) arm (enable) the analyzer for triggering. The EDGE QUALIFIER field (EDGEQ) is used to qualify the ARM X, Δ, Z, 0). Input for this function is channel 33 located on the timing probe.

To demonstrate this feature, set up timing menu as shown in Figure 3-35. Press F3 key to select a rising edge qualifier. Press F6 and COLLECT data. Now hold shorting wire onto channel 33's input point for the A timing probe. Press F6 again. This time the analyzer does not trigger. Remove shorting wire and analyzer will complete its trigger sequence.

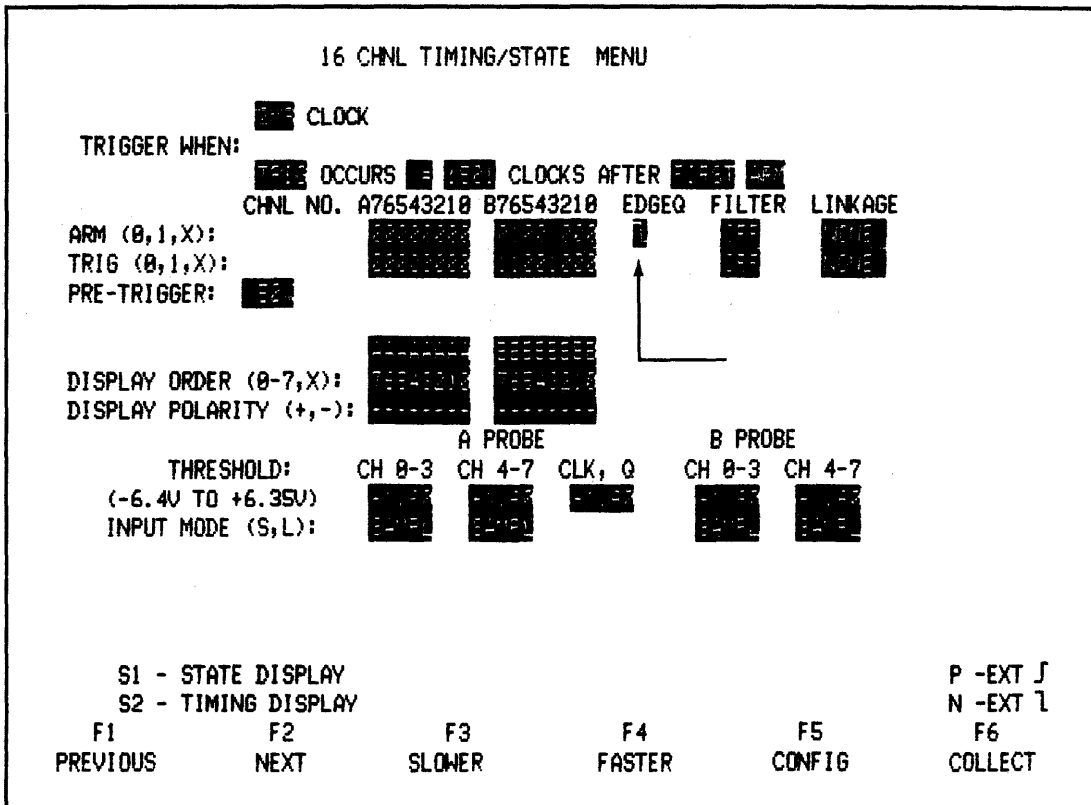

Figure 3-36. Position of Edge Qualification Field In Menu

3.5.35 Using The Qualifier

An explanation is apparent after examining Figure 3-37. The A group of bits are those connected to the B side of test card. Channel B0 shows input to channel 33 of A timing probe. To meet triggering specification, it is necessary for ARM word to be seen and input to channel 33 (qualification input channel) to have a rising edge after the last clock and prior to the occurrence of the ARM word. When shorting wire was connected to channel 33, qualification could not be met and the analyzer failed to trigger. Removal of shorting wire allowed the analyzer to complete its sequence.

This very useful parameter helps with hardware analysis.

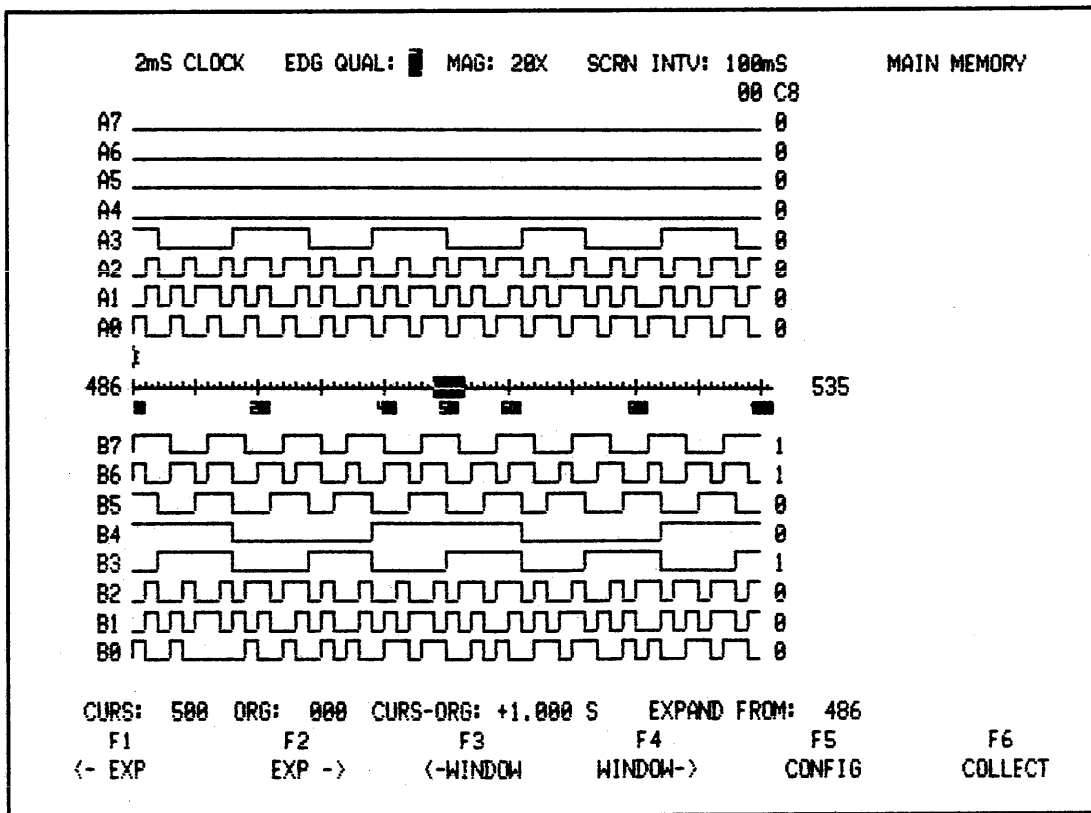

Figure 3-37. Timing Diagram Showing Data Input From Test Card Channels A0-A7 and Input to Edge Qualifier Channel 33 on the A Probe (show as B0 above)

3.5.36 Filter

FILTER sets the number of consecutive clock sample intervals (2-15) during which the ARM word must be stable before it is accepted.

NOTE

Use of 0 or 1 is equivalent to a default value of 1, and turns filter off.

Access ARM field by pressing S2 and the A keys. Then, using NEXT key, step to FILTER field associated with ARM word. Filter fields are used to make certain that associated ARM or TRIG words are stable for 2 to 16 clock sample periods before they are considered valid. This feature avoids generation of false ARM or TRIG words owing to race conditions, propagation delays, or other transient events on the bus.

3.5.37 Threshold

In 16-CHANNEL TIMING mode, threshold level for 16 inputs to the Model 81 probes is keyboard settable in 50 mV increments between -6.40V and $+6.35\text{V}$, in four bit groups. Clock and qualifier inputs, CLK and Q, on the A probe, are adjustable and are independent of data channels. These features are useful for monitoring ECL logic and mixed logic families. When cursor is located in a threshold selection field, a voltage value within the specified range may be entered, or T automatically selects $+1.6$ for TTL, and E selects -0.3 for ECL.

3.5.38 Input Mode

The INPUT MODE, sample or latch, refers to the way in which data are recorded.

3.5.39 Sample

In SAMPLE MODE, (default mode), data on input channels are recorded at the occurrence of selected sampling clock edge. Usually, this records expected data. However, occasionally there is a situation where one signal (or more) to be monitored has a very narrow pulse width, relative to other signals to be monitored. If you select a clock speed fast enough to capture this signal, then the time window (for all 1000 words collected) is too small for other channels.

3.5.40 Latch

To eliminate the need for more memory (and expense), the NPC-800 incorporates latching circuitry at the front end of collection hardware. This circuitry is enabled when the LATCH mode is selected.

If there is a transition on any LATCH'ed input line, that value is stored in a buffer and compared to the value on that line at the NEXT sampling clock. If they are different, then the LATCH'ed value is transferred to data memory board rather than sampled value (see Figure 3-38).

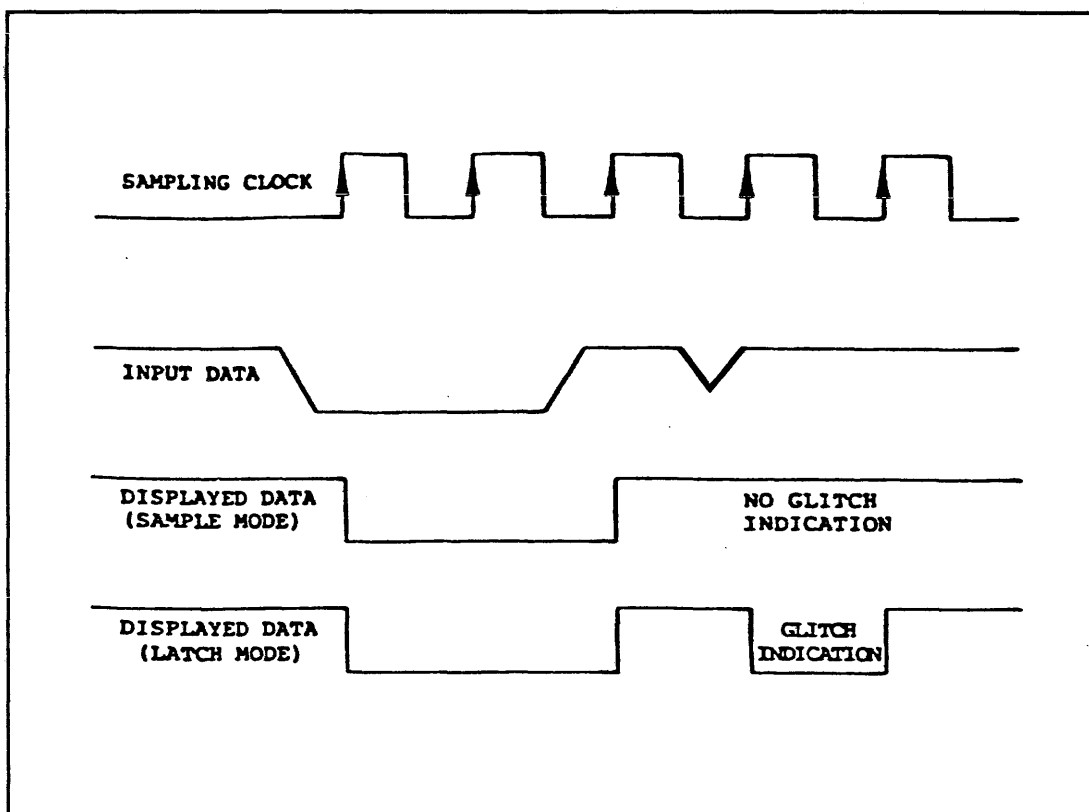

Figure 3-38. Sample and Latch Mode Timing

3.5.41 S1, S2

When using the timing analyzer with an external clock, or monitoring a data or address bus, you may want to view data in state format. As in the state analyzer, you may format data in HEX, OCTAL, DECIMAL, BINARY, or ASCII. Press LABELS key for prompts.

3.5.42 16-Channel State Display

3.5.43 Collect S1

TO CALL DISPLAY

1. Press COLLECT key to perform data collection.
2. If data have been collected and are displayed in timing format, press S1 to call state display.
3. Press LABELS key, then press one of the display format keys (Hexadecimal is used in this example).

MAIN	+023	05	39
	+024	02	7A
LOC: +023	+025	04	7C
	+026	05	81
STG: A1BD	+027	05	C2
A294	+028	0D	44
	+029	0A	22
	+030	05	24
	+031	05	E5
	+032	02	8A
	+033	05	0D
	+034	05	4E
	+035	05	68
	+036	05	AC
	+037	06	EE
	+038	05	51
	+039	05	16
	+040	08	38
	+041	09	F1
	+042	05	B6
	+043	05	19
	+044	02	5A
	+045	04	5C
	+046	05	B9

Figure 3-39. 16-Channel State Display

3.5.44 Linkage

Press T to return to trigger field, step cursor to LINKAGE, and press SELECT (see Figure 3-40).

(W/WLE displayed)

There are two menus available at F1 and F2. Setup state analyzer as in Figure 3-41. Press collect to confirm that you get a data collection. Then press S2, then C and setup timing analyzer as in Figure 3-42.

```

48 CHANNEL STATE MENU

FORMAT: ██████████ ██████████ ██████████ ██████████ ██████████ ██████████
        A ████
CLK SEL: A PRB: █ B PRB: █ C PRB: █ QUALIFIERS FORMAT: -AABBCC EL
CLK QUAL: ████
        OR ████
PRE-TRIG MEMORY (0-999): ████ WORDS
RESTART: ████
TRIGGER:
0      0000XXXXXXXX -XXXXXX XX
1 THEN 0005XXXXXXXX -XXXXXX XX      OCCURS 0040 TIMES
2 THEN 0010XXXXXXXX -XXXXXX XX      AFTER 5500 CLOCKS
3 THEN 0015XXXXXXXX -XXXXXX XX      OCCURS 0054 TIMES

H - HEX
O - OCTAL
Z - DEC
N - BINARY
Y - ASCII
U - USER

S1 - DATA DISPLAY
F1  F2  F3  F4  F5  F6
PREVIOUS NEXT SELECT DEFAULT CONFIG COLLECT
    
```

Figure 3-41. State Menu for Linking State To Timing

3.6.4 Application

As an example of linking the state analyzer to the timing analyzer, consider a process control application. Here, this type of linkage could be used to monitor control signals generated as a result of a specific subroutine being executed.

3.6.5 Disabling the L Bit

With the timing display on the CRT, access ARM field by pressing A key. Step to LINKAGE field and select NONE (Once in LINKAGE field, pressing DEFAULT key is another way to do this).

3.6.6 Linking Timing to State

Press S1 and T keys to call state menu. Using the L bit in trigger qualifier field, any sequential trigger word in the state analyzer's 16-level trigger word stack can be linked to occurrences in timing domain. Use NEXT key to step down to level 1. Then use SPACE BAR to access L bit, which is last bit in trigger qualifier. Set this bit to 1 as shown in Figure 3-43.

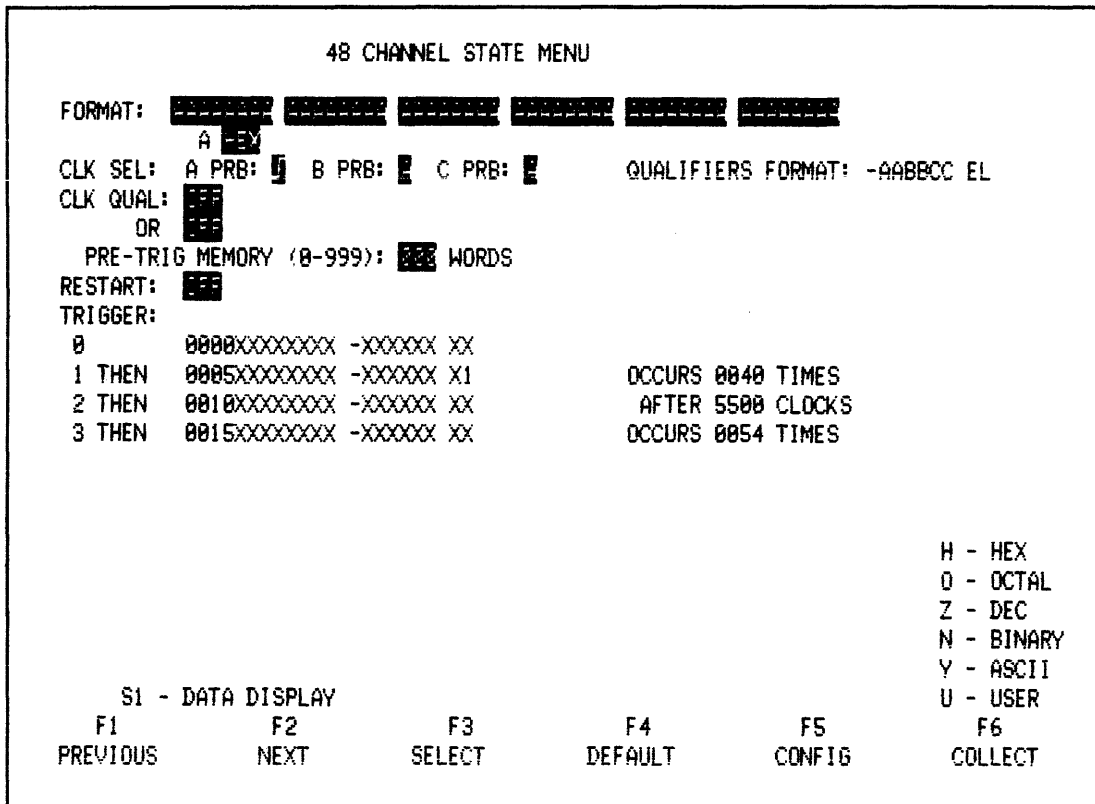

Figure 3-43. Linking State Analyzer's TRIGGER LEVEL 1 to Timing Analyzer

3.6.7 Collect

Press COLLECT key and watch trigger status messages go through the following sequence:

```

TIMING: SAMPLING                STATE: LEVEL 0/1
                                  LEVEL 0/1

    ARMED
    TRIGGERED -----LEVEL 1
    (LINKAGE)

    DONE                          LEVEL 2
                                  LEVEL 3
                                  TRIGGERED
                                  DONE

```

Notice how the state analyzer automatically restarts at level 0 until the timing analyzer completes its triggering sequence. When timing trigger sequence is complete, the state analyzer advances through trigger stack.

Press S2 and S1 keys to switch between state and timing displays. As an example, this type of linkage could be used to monitor the subroutine called by the occurrence of an interrupt. You are encouraged to experiment with other linkage setups.

NOTE

Linkage conditions should not be set in both analyzers simultaneously. (Neither analyzer will trigger.)

3.7 GLITCH CAPTURE

3.7.1 Eight-Channel Glitch Memory Mode

The NPC-800's 8-CHANNEL GLITCH MEMORY mode allows you to capture 3 nanosecond glitches and display them along with eight channels of data. It is important to distinguish between this mode and the conventional 3 nanosecond glitch latch capabilities of the previously described 16-channel timing configuration (which does not incorporate a separate glitch memory). In the conventional 3 nanosecond latch mode, the analyzer arms a latch to capture any transitions occurring before the next sample clock edge. If a transition does occur, the latch is set and sampled at next clock edge. For a narrow glitch, whose width is less than the clock sample period, the display shows the glitch as one clock-period wide.

3.7.2 Hardware

In the glitch capture mode, the NPC-800 uses two adjacent input lines to store timing information in one memory, and glitch information in the other memory. To eliminate connecting two inputs to your circuit, a terminator, M83, for dual threshold setups is provided with each timing probe (in this example for glitch capture).

Glitches of 3 nanoseconds duration or longer, which occur between sample clock edges, are stored in separate glitch memory. Upon display, a glitch is shown as a vertical line interspersed with data (see Figure 3-44).

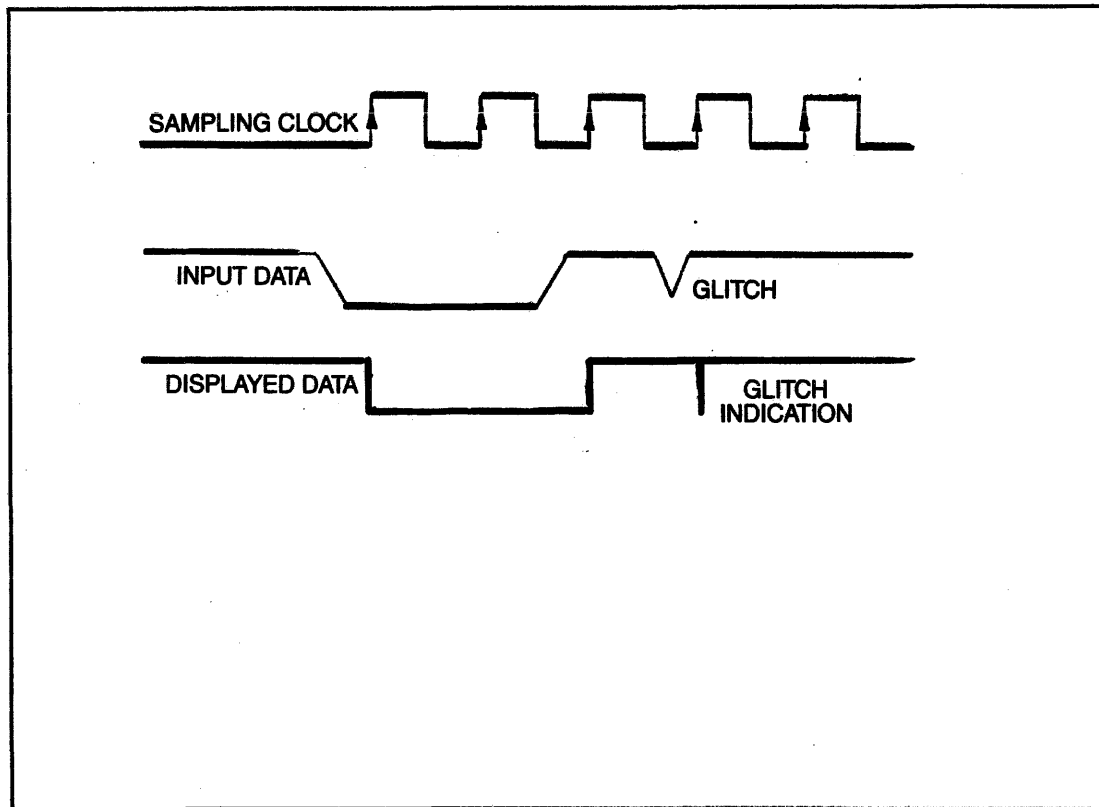

Figure 3-44. Glitch Interspersed With Data

3.7.3 Setup

Press RESET key. Select 8-CHANNEL TIMING GLITCH mode from CONFIGURATION LIST. Set in a clock speed of one millisecond.

3.7.4 Connect

Connect M83 to A timing probe; then install a microhook on to the A0 channel. Attach microhook to pin 3 of U2 on test card. To provide power to circuitry, connect A state probe to A side of test card.

3.7.5 Collect S2

Press COLLECT to take a data collection. With timing data displayed as X20, move window (if necessary) to obtain a display similar to Figure 3-45. Notice glitch indications on channel A0. Because the definition of a glitch is any transition which occurs between sample clocks, the use of relatively slow (1 millisecond) clock allows “glitches” to be viewed. If you don’t get at least one “glitch” on channel A0, press COLLECT again or use a 2 millisecond clock.)

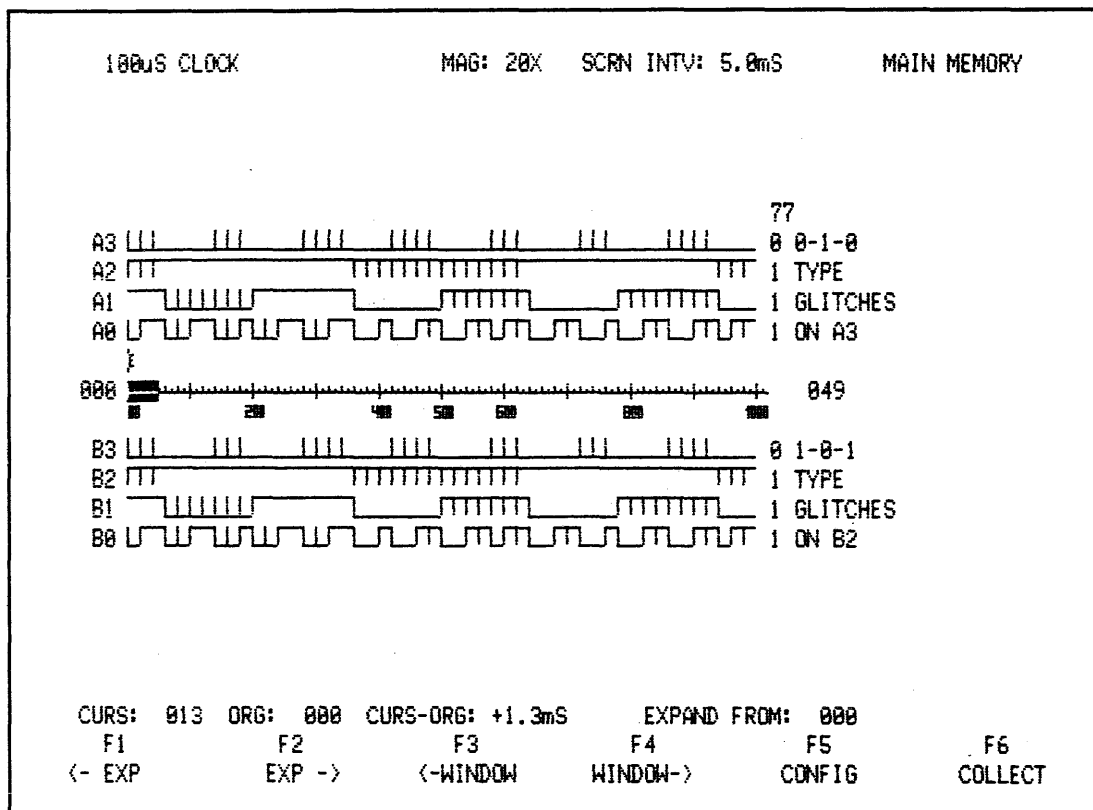

Figure 3-45. Timing Display With Glitches
 (Your display will differ since no trigger word was specified)

3.8 75MHz SYNCHRONOUS ANALYSIS

3.8.1 External Clock

The NPC-800 has one of the fastest synchronous collection speeds available.

This example uses an external clock with the timing analyzer. Maximum clock rate is 75 MHz. Press RESET, select 16-Channel Timing, S2 and C key to get into clock field in timing menu. Using P or N key (note prompt at lower right of screen), select an external clock with a rising or falling edge. One bit, which is available for clock qualification, can be used by connecting qualifying channel to line 33 on A probe and setting 1 or 0 in menu field. Press COLLECT key and note changes to timing diagram: clock specification is now external clock, and time difference is now measured in clock cycles(CS) (see Figure 3-46).

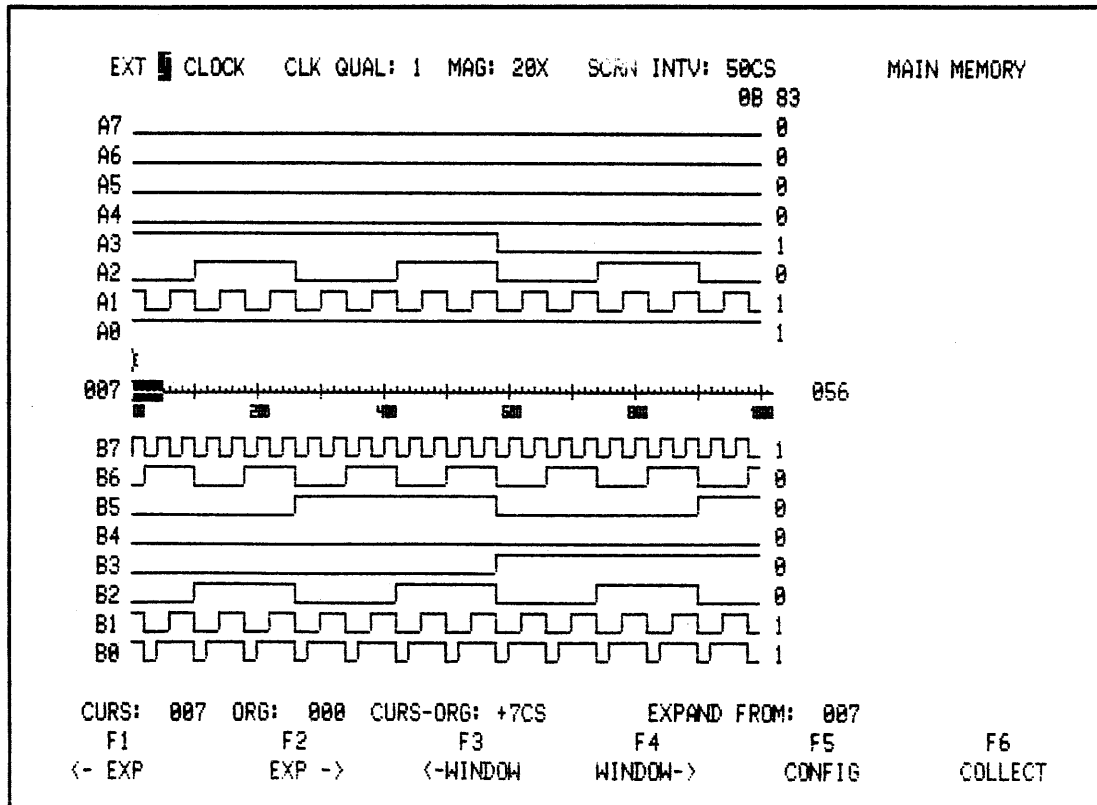

Figure 3-46. Timing Diagram Using An External Clock

You still have all of the trigger capabilities and display manipulation features discussed earlier. For example, in this mode you probably want data displayed in state format. Press S1 to switch format, then press LABELS for prompts for valid keystrokes.

Press S1 to view data in state format.

MAIN	+023	05	39
	+024	02	7A
LCC: +023	+025	04	7C
	+026	05	81
SIG: A18D	+027	05	C2
A294	+028	0D	44
	+029	0A	22
	+030	05	24
	+031	05	E5
	+032	02	8A
	+033	05	0D
	+034	05	4E
	+035	05	68
	+036	05	AC
	+037	06	EE
	+038	05	51
	+039	05	16
	+040	08	30
	+041	09	F1
	+042	05	B6
	+043	05	19
	+044	02	5A
	+045	04	5C

Figure 3-47. High Speed Synchronous Data Displayed In State Format

3.9 FREQUENCY COUNTER/INTERVAL TIMER/SIGNATURE ANALYZER

3.9.1 CT/SA

The Frequency Counter/Interval Timer/Signature Analyzer is an optional circuit board that installs inside the NPC-800. It comes with a standard oscilloscope-type probe, and is used to measure frequency, period, intervals, total count of events, or single-node signature analysis of serial data. It is very useful in verifying time-domain parameters of your digital system. For example, you can measure the time a software subroutine takes to execute.

3.9.2 Histograms

This hardware, which also is used with the Performance Analysis software option, displays bar charts of overall system operation/performance.

3.9.3 Basic Counter-Timer/(Optional CT/SA Board Must Be Installed)*

To demonstrate basic features of the optional counter-timer and signature analysis functions of the NPC-800, the Model 90 probe is used to monitor signals on the test card. Connect probe to rear panel input connector labeled CTSA. Set Model 90 probe for X10 operation.

3.9.4 Counter-Timer Menus

Three illustrative counter-timer menus are shown below:

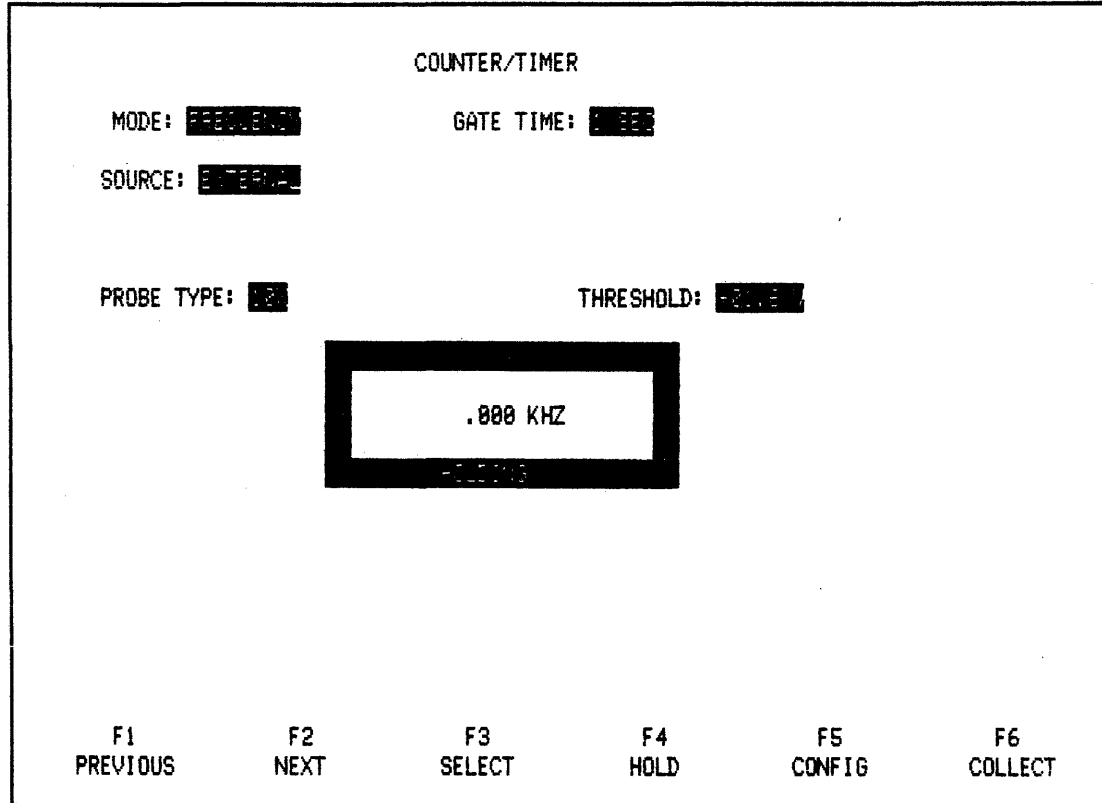
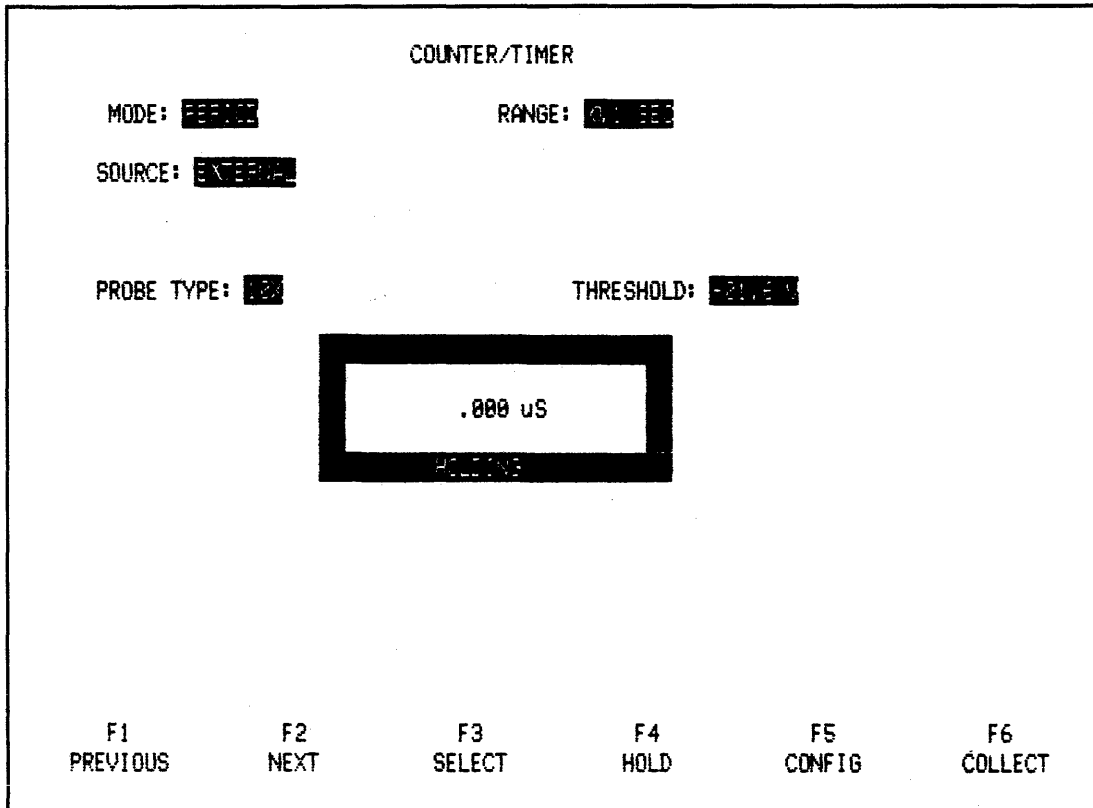

Figure 3-48. Frequency Mode With External As Source (Using Model 90 probe)



**Figure 3-49. Period Mode With External Source
(Using State Probes; Total Mode Is Similar)**

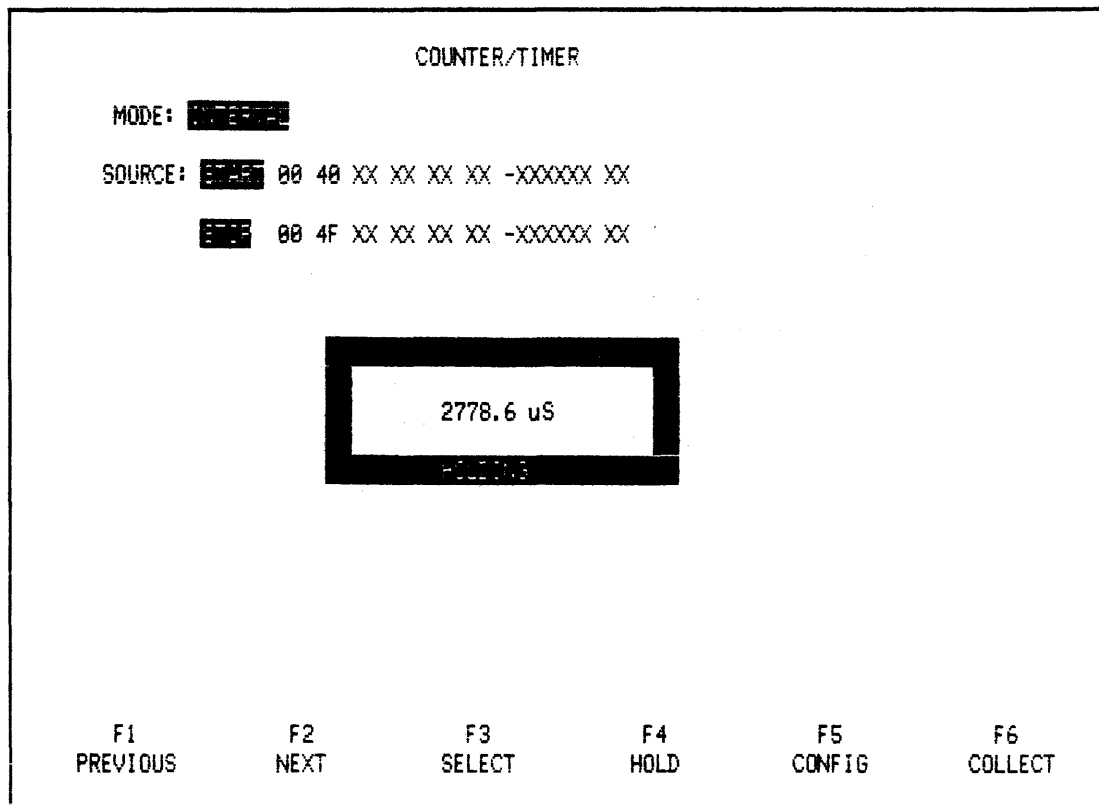

Figure 3-50. Interval Mode With State Data Probes As Source

3.9.5 To Call Up Menu

1. Press RESET key.
2. Press SEL DOWN or SEL UP key to select COUNTER-TIMER MODE.
3. Press SELECT (F1) key to call the menu.

3.9.6 Explanation Of Menu

The user can select from the following counter-timer modes: FREQUENCY, PERIOD, INTERVAL, and TOTAL. Measurements can be made of individual signals using the Model 90 scope probe or of state events using the analyzer's 16-channel state probes.

FREQUENCY mode: measures individual signals up to 100 MHz using the Model 90 probe. Using the 16-channel state probes, this mode can measure state events up to 10 MHz.

PERIOD mode: inverse of FREQUENCY mode.

TOTAL mode: measures total number of occurrences of single events monitored by the Model 90 probe, or state events monitored by 16-channel state probes.

GATE TIME: used in FREQUENCY mode only. GATE TIME is time interval over which frequency is measured and can be selected from 10 milliseconds to 10 seconds.

RANGE: used in PERIOD mode only. RANGE is maximum period which can be measured and can be selected from 10 millisecond to 10 seconds.

SOURCE: in FREQUENCY, PERIOD, AND TOTAL modes, the SOURCE field can be selected as EXTERNAL (Model 90 probe), PRESCALE (EXTERNAL/10), or DATA (state probes). PRESCALE mode must be selected for measurements above 10 MHz (100 MHz maximum). DATA mode allows measurements to be made on state events up to 56-bits wide.

INTERVAL mode: SOURCE field allows specification of START and STOP words, each 38-56 bits wide.

PROBE TYPE: this field is displayed only in FREQUENCY, PERIOD, and TOTAL modes, and only when SOURCE field is EXTERNAL or PRESCALE (EXT/10). Depending on the setting of switch on the Model 90 probe, the two options are 10X and 1X.

THRESHOLD: this field is available only when the PROBE TYPE field is displayed. When a 10X probe type is selected, the threshold for an incoming signal can be set between $-25.4V$ and $+25.6V$, in $0.2V$ increments. When a 1X probe type is selected, the threshold can be set between $-2.54V$ and $+2.56V$, in $0.02V$ increments.

3.9.7 Basic Counter/Timer Example

This section illustrates the use of the NPC-800 to make frequency (or period) measurements and totalize events using the Model 90 probe.

3.9.8 Menu

Press CONFIG key and step down to COUNTER-TIMER mode. Then press SELECT key to display COUNTER-TIMER menu (see Figure 3-51).

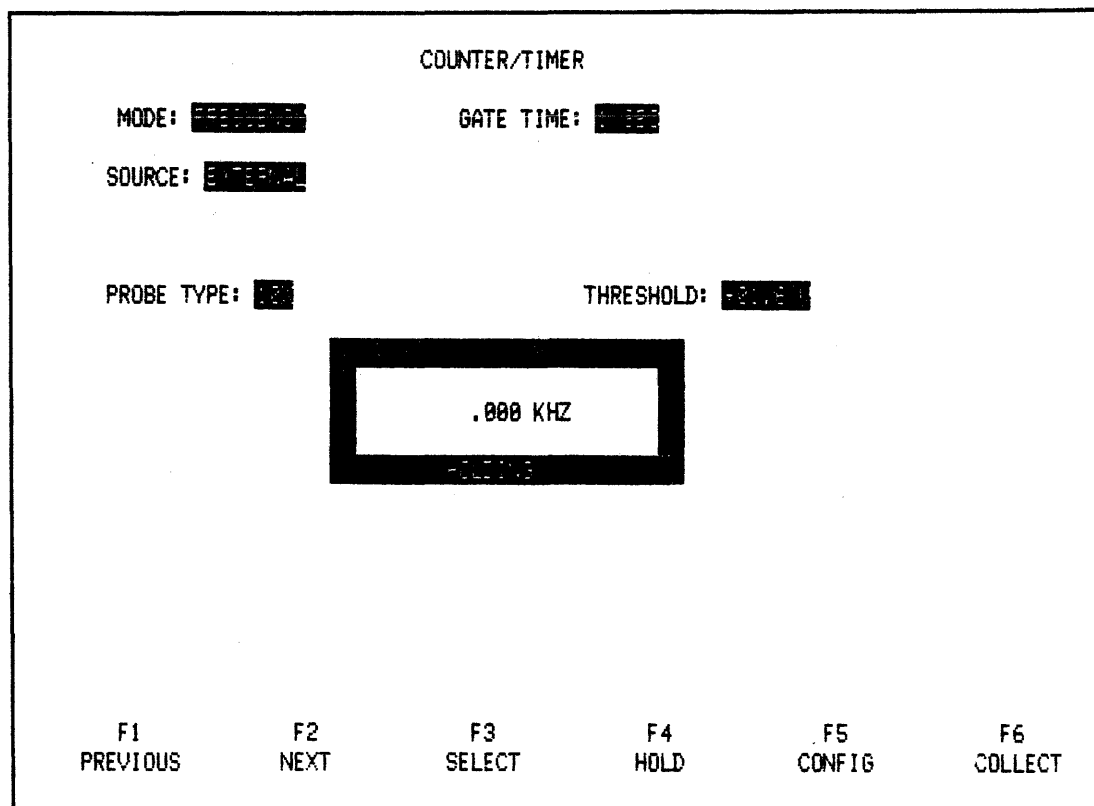

Figure 3-51. COUNTER-TIMER Menu

NOTE

Rectangular display window is blank if CT/SA option is not installed.

3.9.9 Counter-Timer Display

The counter-timer display is incorporated into the menu. To measure a signal, simply connect appropriate probe(s). Frequency, time, or count of input events appears in rectangle on screen. Also, message COLLECTING appears below reading to indicate real-time nature of current measurement. To “freeze” measurement, press HOLD (F4) key; message HOLDING then appears below reading.

3.9.10 Advanced Counter-Timer Example

In addition to the basic use of the counter-timer to measure simple events using the Model 90 probe, the NPC-800 can be used to make counter-timer measurements of bus or other state events as monitored by three-state probes.

3.9.11 State-Related Measurements

Frequency, period, and count measurements can be made by specifying a cyclical or repeating data word or event; interval measurements can be made by specifying two data words or events. For both, the data word can be specified as having up to 56 bits. These include 48 bits of data from A, B, and C channel probes and eight additional bits of clock qualifiers: six (two each) from A, B, and C channel probes (AABBCC), one external trigger bit (E), and one

linkage bit (L). The following procedure illustrates the use of the counter-timer for state-related measurements.

As before, A state probe should be plugged into A side of test cards.

3.9.12 Frequency

Using F1 or F2, move to mode field and select frequency with F3 key.

3.9.13 Source: Data

Next, step cursor to SOURCE field and select DATA. When DATA is the source, the field for data word is automatically displayed in the format previously selected in the state menu. Then enter data word: 0040 (rest X's) (see Figure 3-52).

3.9.14 Collect

Press COLLECT key to begin counter-timer. Notice that display indicates frequency of occurrence of specified data word being monitored by A probe (remaining bits of B and C channel probes are each set to DON'T CARE as are clock qualifier bits AABBC EL). Pressing HOLD (F4) key causes last measurement to be held on display. Pressing COLLECT again causes counter-timer to resume making measurements.

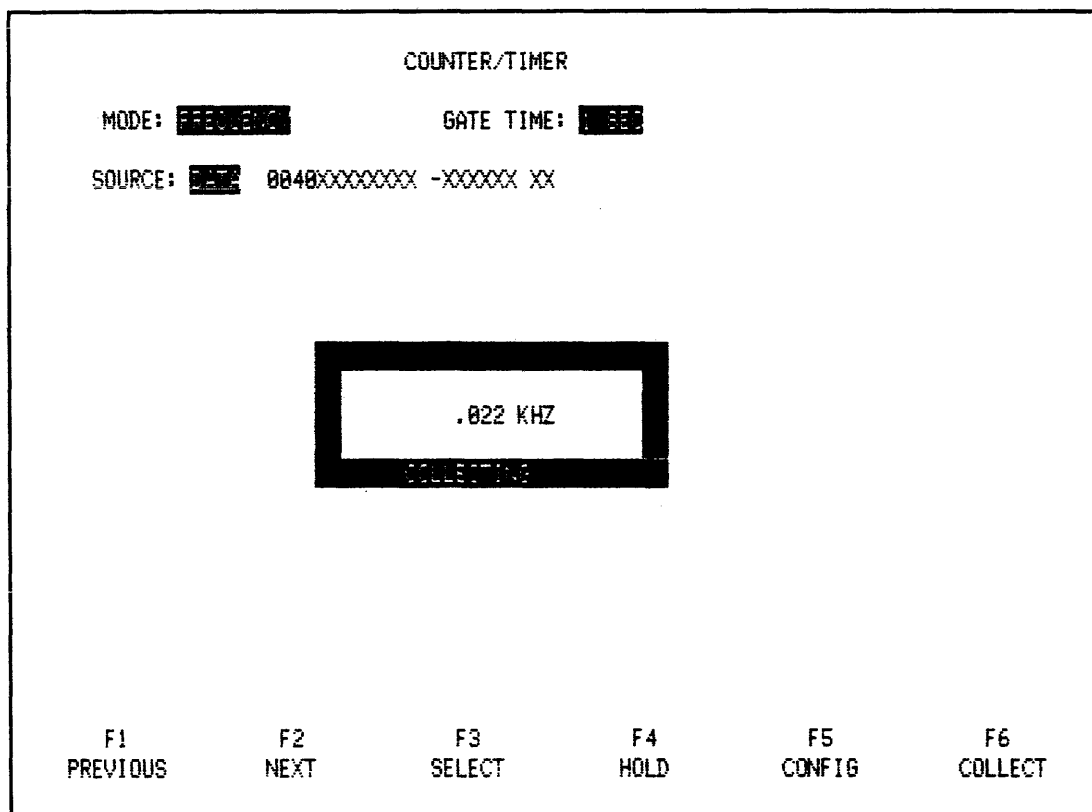

Figure 3-52. Counter-Timer Display Indicating Frequency of Occurrence of Specified Data Word

3.9.15 Select

Move cursor through menu and back to MODE field. Notice that counter-timer remains functioning and collecting even while cursor is moved within menu. Press SELECT key to change modes to PERIOD, INTERVAL, and TOTAL and watch display reflect mode selected.

As in the basic counter-timer example, pressing HOLD key holds measured data; while pressing COLLECT key restarts measurement.

3.9.16 Interval Mode

All modes with the exception of INTERVAL only require a single event. As the name implies, INTERVAL refers to the time between two events and thus requires two data words: START and STOP. When INTERVAL mode is entered, the fields for two data words are displayed. The fields are identical to those of the single data word, 48 bits plus 8 additional qualifiers.

3.9.17 Collect

Select INTERVAL mode and step cursor to SOURCE field. Enter 0040 (rest X's) and 00FF (rest X's) in START and STOP fields, respectively. When finished, press COLLECT key and watch display indicate interval (in microseconds) between the two data words (see Figure 3-53). Notice that interval timer continues making and displaying measurements until HOLD key is pressed.

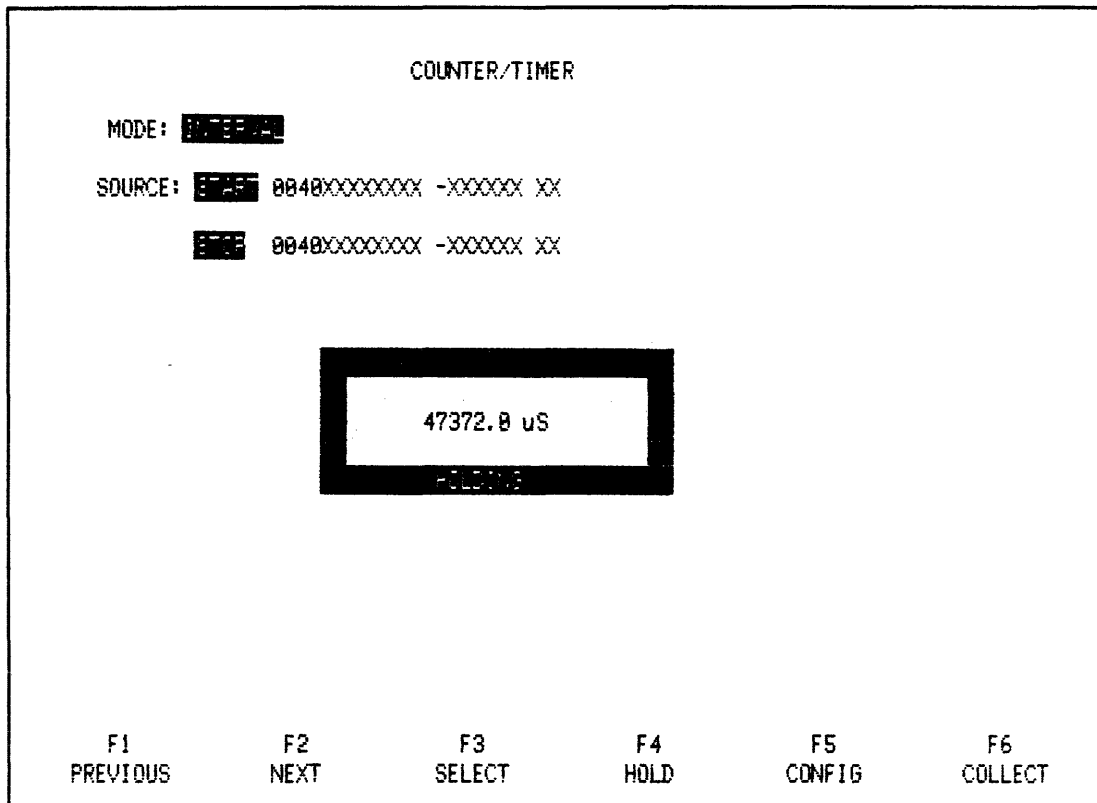

Figure 3-53. Counter-Timer Measurements of Interval Between START and STOP Data Words

3.9.18 Frequency

You're now ready to make a frequency measurement. Hold probe on data line DB0, on test card (A channel side) and watch NPC-800 as it displays frequency (see Figure 3-54). Notice that message COLLECTING, which appears under counter-timer display, indicates NPC-800 is in a real-time measurement mode. Press HOLD (F4) to hold a particular reading.

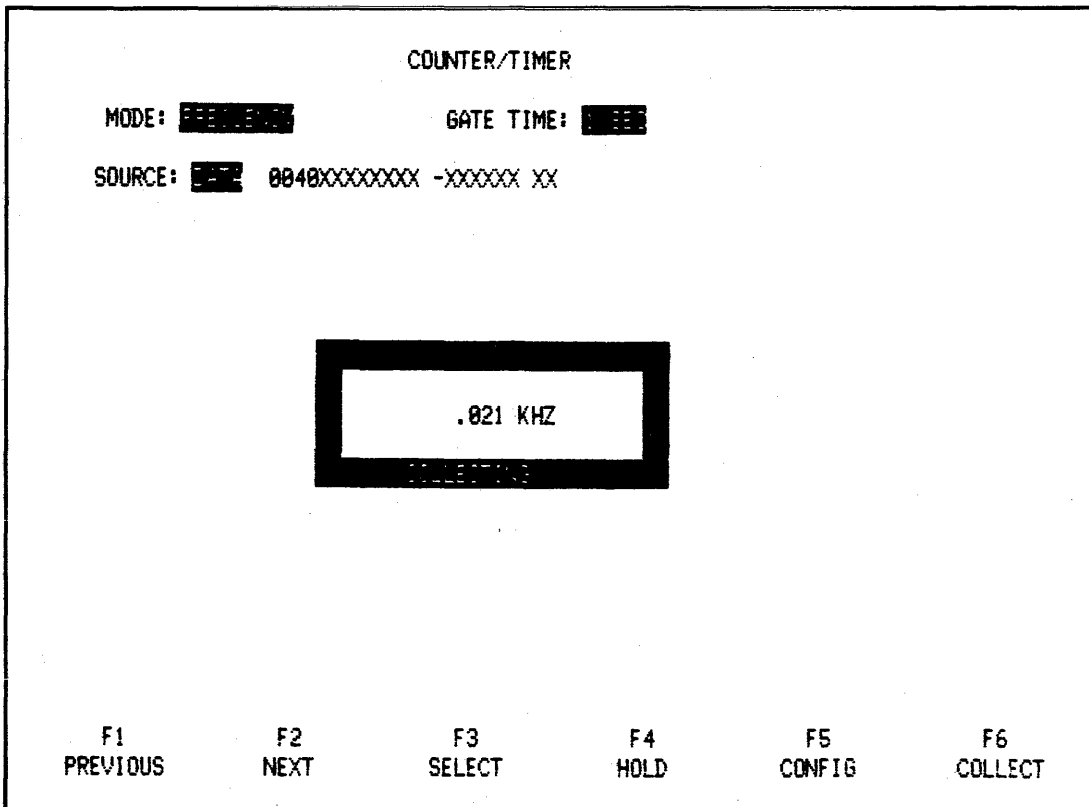

Figure 3-54. Frequency Measurement Using Counter-Timer

3.9.19 Period

With cursor in MODE field and probe still on DB0, use SELECT key to change mode to PERIOD. Notice that display now measures in units of time (microseconds) instead of frequency (kHz). Also, notice that GATE TIME field changes to RANGE when mode is changed to PERIOD. GATE TIME indicates interval over which frequency is measured and also interval between display updates. RANGE indicates maximum period which can be measured (see Figure 3-55).

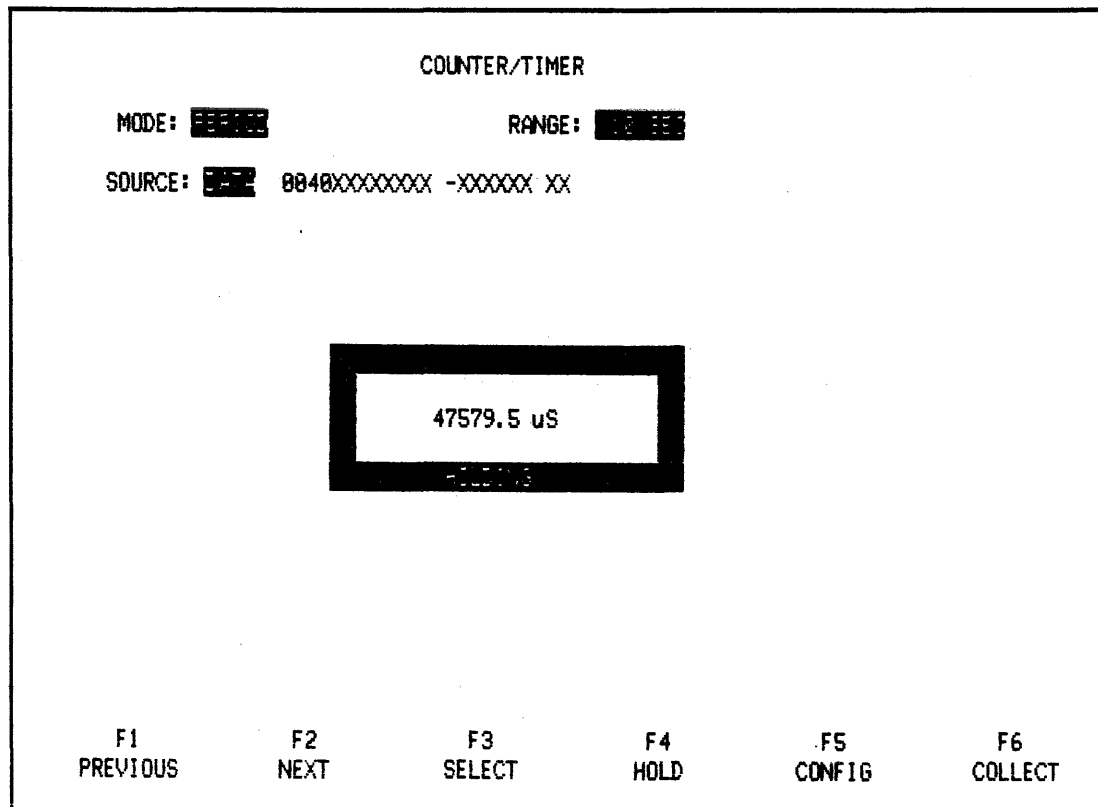

Figure 3-55. Period Measurement Using Counter-Timer

3.9.20 Hold

Next, press HOLD key (F4). This causes display to hold last measurement and displays the message HOLDING under the value. Press COLLECT key to restart counter-timer. The message COLLECTING again appears under counter-timer display.

3.9.21 Probe And Threshold

The other two parameters, which were used (PROBE TYPE and THRESHOLD) set the input signal voltage range. If probe setting and menu are both set to 1X, the range of threshold settings which can be used is anywhere from -2.54V to $+2.56\text{V}$, in 0.02V increments. With a probe setting of 10X in the menu, and the Model 90 probe set to X10, the range of threshold voltages is from -25.4V to $+25.6\text{V}$, in 0.2V increments.

3.9.22 Basic Signature Analysis (Example)

This section illustrates basic signature analyzer features of the optional Counter-Timer/Signature Analyzer board. The NPC-800 can be used to perform the function of a traditional signature analyzer (Hewlett Packard 5004A or equivalent) which uses individual lines for start, stop, and clock signals.

3.9.23 Discussion

Briefly, signature analysis is a troubleshooting technique that uses a data compression algorithm to reduce a complex, serial data stream to a unique 4-digit signature. To develop a

signature, a START bit, STOP bit, CLOCK, and a serial data signal are required. In most signature analyzers, each of these signals requires a single line connected to the circuit board being tested.

By comparison, the NPC-800 allows the use of up to 56 bits to define START and STOP signals. The CLOCK signal is specified in the state menu (A, B, and C clock edges and clock qualifiers). The serial data signal is provided through the Model 90 probe connected to rear panel input connector labeled CTSA.

For testing logic other than TTL (for example, ECL), NPC-800's signature analyzer allows variable-threshold signal levels to be input to the serial data probe. By using the analyzer probes adjustable threshold feature, it also allows a variable threshold implementation of START, STOP, and CLOCK signals.

3.9.24 Signature Menu

3.9.25 To Call Up Menu

1. Press CONFIG or RESET key.
2. Press SEL DOWN or SEL UP key to select SIGNATURE ANALYZER mode.
3. Press SELECT (F1) key to call menu.

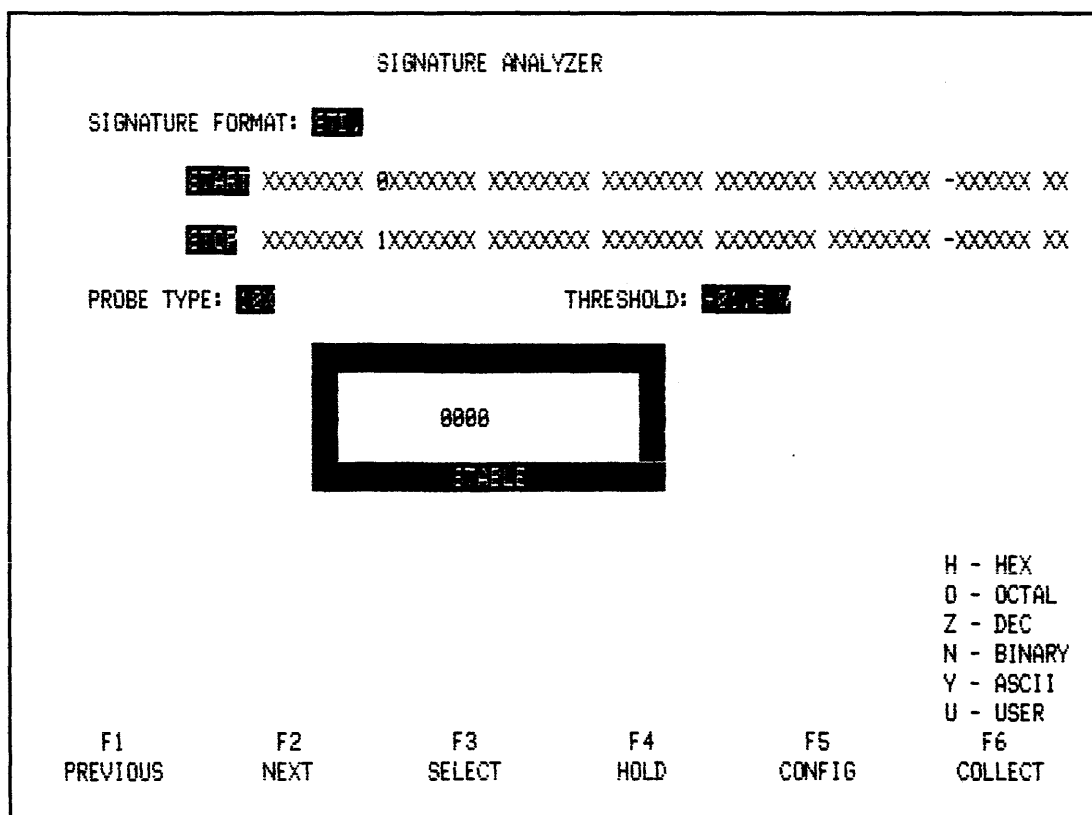

Figure 3-56. Use of Single Bit START and STOP Words

3.9.26 Explanation of Menu

SIGNATURE FORMAT: two formats can be selected, STD or HEX. STD format uses the 7-segment alphanumeric type of display of the HP-5004A Signature Analyzer (0-9, A, C, F, H, P, U). HEX format displays signatures in hexadecimal (0-9, A-F).

START AND STOP: START and STOP words gate the serial bit stream coming through the Model 90 probe. A logic zero in any bit position corresponds to () on the HP-5004A; while a logic one corresponds to ().

START and STOP Words: automatically formatted in accordance with the user's display format in the 48-channel state menu. A single format can be selected using HEX, OCT, BIN, DEC, or ASC keys.

PROBE TYPE: To match corresponding settings of the Model 90 probe, two options are provided, 10X and 1X.

THRESHOLD: when a 10X probe type is selected, the threshold for an incoming signal can be set between -25.4V and $+25.6\text{V}$, in 0.2V increments. When a 1X probe type is selected, the threshold can be set between -2.54V and $+2.56\text{V}$, in 0.02V increments.

NOTE

In a typical application, the clock used in conjunction with the serial bit stream being monitored should be derived from the A state probe. Set this clock for a rising or falling active edge in the state menu as appropriate. Be sure B (and C) clock fields are set to A.

SIGNATURE DISPLAY: incorporated into the menu, it takes a signature of a serial bit stream being monitored by the Model 90 probe. Simply touch probe to node and press COLLECT key.

3.9.27 To Setup Menu

3.9.28 Start/Stop

Using NEXT or PREVIOUS keys (as required), move cursor to START field. START word is always displayed in the format used in the state menu. Press N (Binary) key to display START word in a binary format. Next, enter single-bit START word (0) in ninth bit position from left. Press NEXT key to move to STOP field. Then press N (Binary) key and enter single-bit STOP word (1) in the same position as before (see Figure 3-57).

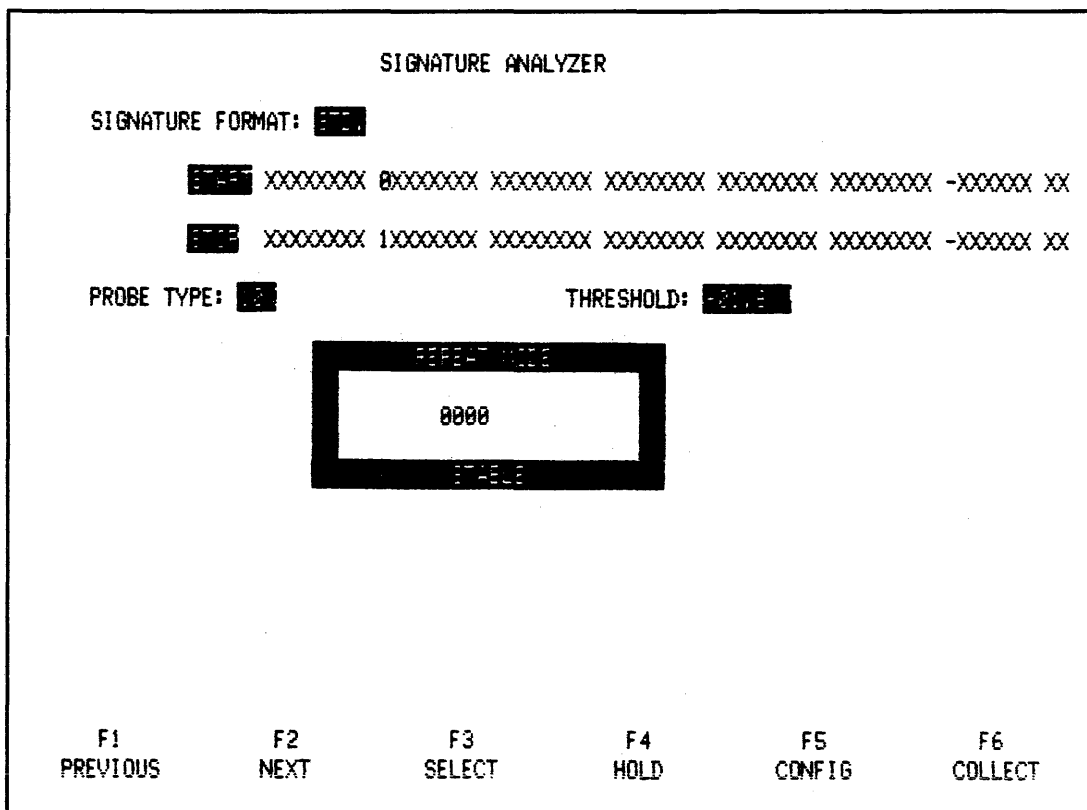

Figure 3-57. Use of Single Bit START and STOP Words

Connect A and B state probes to test card's A and B outputs. Press COLLECT key. A signature can now be taken for any serial stream on the test card in the interval between single-bit START and STOP words.

3.9.29 Signatures

When you want to take a signature of a test point, simply touch the circuit node of interest. For example, touch the Model 90 probe tip to the B channel data lines (labeled DB0-DB7), one at a time; the NPC-800 automatically displays the signature of the data line being tested (see Figure 3-58).

Notice that each time you take a serial collection resulting in a new signature, the display underneath the signature reads UNSTABLE (changing) for approximately a second, then switches to STABLE. However, if the signature collection is the same for successive measurements, only the message STABLE is displayed.

Also notice that the signature window displays REPEAT MODE above the signature. This is the automatic mode mentioned above. Press HOLD (F4) key to hold displayed signature; press COLLECT key to return to automatic mode.

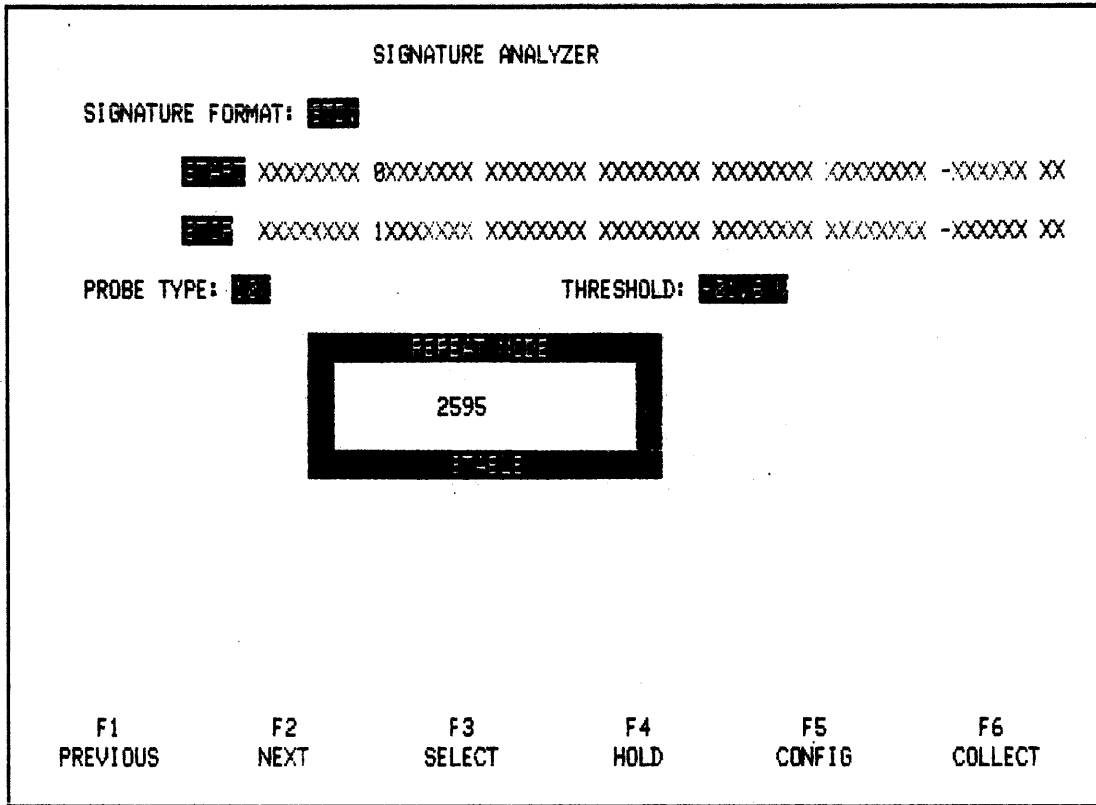

Figure 3-58. Display of Signature for Test Point DB0 of the B Channel
 (your signature may differ because there are several versions of the test card in the field)

3.9.30 Fault-Isolation

Using REPEAT mode, generate a fault. With probe on DB0 on B channel side of the test card, place shorting wire on pin 2 of U3. U3 is located at top center of test card. This fault changes the counting sequence of the B counter. Press COLLECT to obtain a new signature for test point DB0. Notice that new signature shown in Figure 3-59 differs from signature in Figure 3-58.

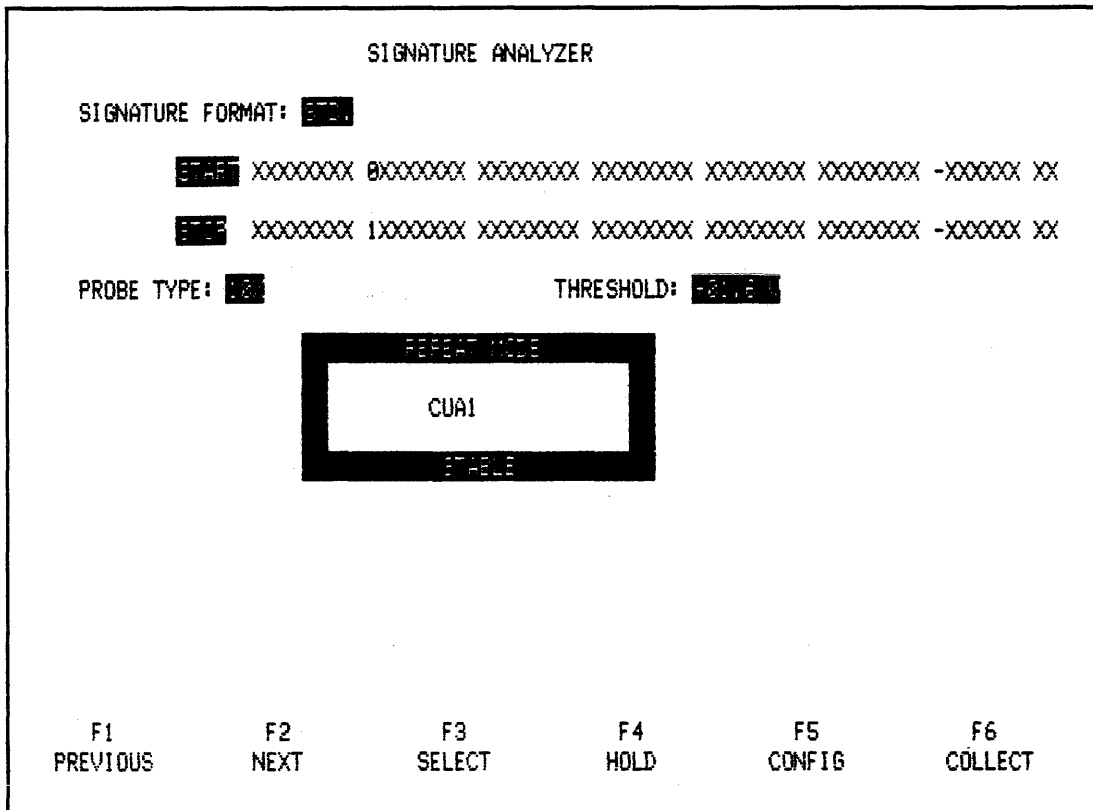

Figure 3-59. New Signature For DB0 (B Counter)

3.9.31 Advanced Signature Analysis (Example)

NPC-800's signature analyzer provides additional capabilities that can be used to test complex state sequences. Often, digital systems do not contain separate on-board start and stop signals representing complex events. NPC-800's 56-bit-wide word recognition circuitry can be used to supply necessary signals (In the previous basic example, a single bit was used for both start and stop signals). For advanced applications, the entire 56-bit-wide trigger word, consisting of 48 data bits and 6 qualifiers from the data probes plus the E and L bits, can be used to control the signature analyzer. E bit provides a single bit qualification for independent synchronization from a signal anywhere in the circuitry that's being tested. L bit provides a powerful linkage capability to one or more additional logic analyzers.

3.9.32 Software Signatures

As a practical example, the beginning and ending addresses of a software routine could be used to gate the signature analyzer. By placing the Model 90 probe on the LSB of the address word during program execution, a unique signature of executing code is obtained. In this manner, faulty software or "unannounced" revisions can be rapidly uncovered.

3.10 ANALOG WAVEFORM RECORDER

The Analog Waveform Recorder option provides the user with an easy-to-use instrument very similar to a digital oscilloscope. The menu allows you to set up the same parameters that you would on an oscilloscope, except that you do it from the keyboard rather than using knobs. It samples analog signals, using a standard oscilloscope-type probe, at speeds up to 50

MHz. At each clock sample, the analog data undergoes a analog-to-digital conversion, with 6 bits of accuracy. The reconstructed analog data can then be displayed on the CRT as a waveform, or it can be used to trigger the logic analyzer.

3.10.1 Basic Waveform Analysis (Optional Waveform Analyzer Must Be Installed)*

To demonstrate basic waveform recording features of the NPC-800C, the user need only set desired sample period, the vertical axis attenuation factor (dependent on input signal levels), connect scope probe to waveform test point on test card, and press COLLECT. After data collection, captured waveform may be magnified, measured, and stored in a manner similar to timing diagram display discussed previously. In addition, voltage information is displayed.

3.10.2 Waveform Menu (1000 Words, 50 MHz)

3.10.3 To Call Up Menu

1. Press CONFIG or RESET key.
2. Press SEL DOWN or SEL UP to select WAVEFORM RECORDER mode.
3. Press WAVEFORM (F1) key to call menu.

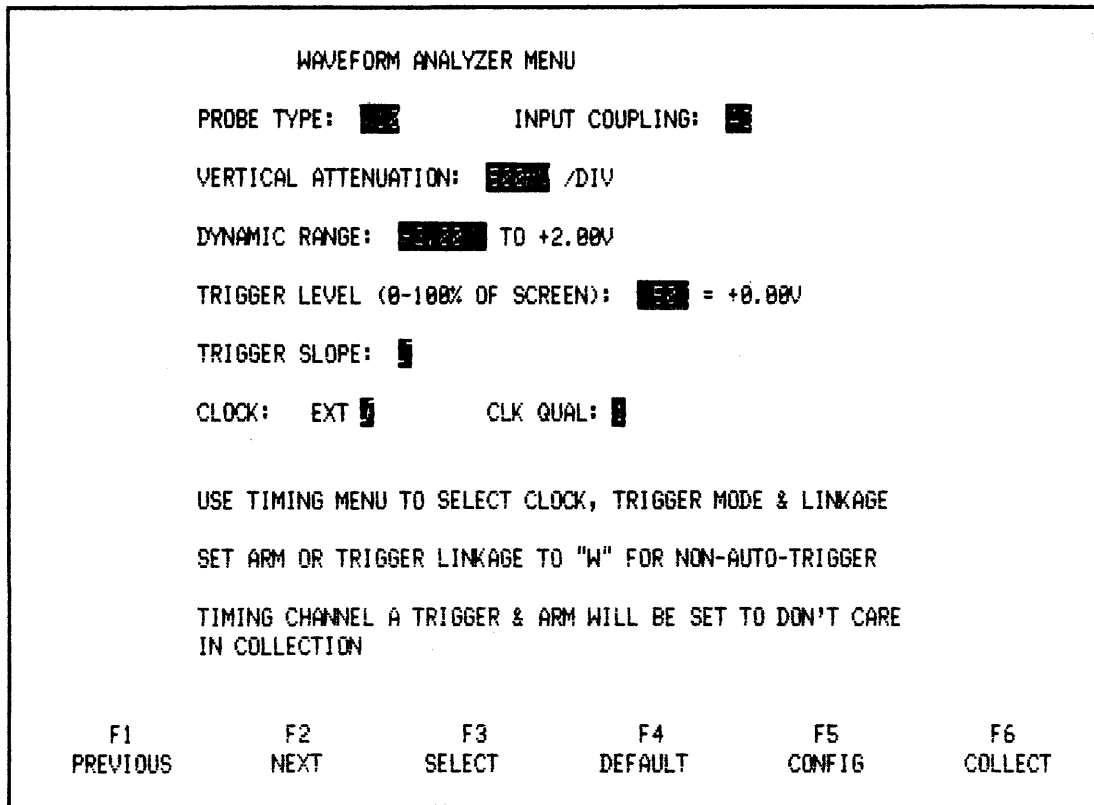

Figure 3-60. Waveform Menu

* If Waveform option is not installed, a baseline in the waveform display is not present when COLLECT key is pressed.

3.10.4 Explanation of Menu

Line 1: PROBE TYPE (X10,X1). This field configures the waveform analyzer for the type of probe used: INPUT COUPLING, DC, AC, GND. A match with the probe setting is required.

Line 2: ATTENUATOR. 5mV/DIV to 20V/DIV (X1 probe); 50mV/DIV to 200V/DIV (X10 probe).

Line 3: DYNAMIC RANGE. Select lower value to position voltage window. Input waveforms within this range are digitized, without saturation, by a/d converter.

Line 4: TRIGGER LEVEL. Threshold level for incoming waveform that causes analyzer to trigger.

Line 5: TRIGGER SLOPE. Rising or falling. This is the waveform slope at the threshold crossing required for triggering.

Line 6: Sampling rate value. This parameter is set in timing menu.

Lines 7-9: Instructions to use timing menu to set up sample clock rate. Trigger mode (including pretrigger), and linkage. For threshold and slope parameters of the waveform menu to be active, a W must be set into linkage portion of ARM or TRIG field; otherwise, waveform analyzer operates in an Auto-Trigger (free-running) mode when COLLECT is pressed.

3.10.5 Waveform (Example)

Press CONFIG key and step down to mode labeled WAVEFORM RECORDER. Press WAVEFORM (F1) key to call waveform menu. Connect Model 90 scope probe to WAVEFORM BNC at rear of NPC-800C. Set probe switch to X10 position.

Waveform menu contains typical oscilloscope-type parameters. Since default values are not appropriate for this example, these values should be changed as shown in Figure 6-31. Use keys F3 and F4 to change parameters in waveform menu.

```

                                WAVEFORM ANALYZER MENU

PROBE TYPE:  [ ]          INPUT COUPLING:  [ ]

VERTICAL ATTENUATION:  [ ] /DIV

DYNAMIC RANGE:  [ ] TO +6.40V

TRIGGER LEVEL (0-100% OF SCREEN):  [ ] = +2.40V

TRIGGER SLOPE:  [ ]

CLOCK:      1uS

USE TIMING MENU TO SELECT CLOCK, TRIGGER MODE & LINKAGE

SET ARM OR TRIGGER LINKAGE TO "W" FOR NON-AUTO-TRIGGER

TIMING CHANNEL A TRIGGER & ARM WILL BE SET TO DON'T CARE
IN COLLECTION

F1          F2          F3          F4          F5          F6
PREVIOUS    NEXT       INCR      DECR      CONFIG    COLLECT

```

Figure 3-61. Waveform Menu (See paragraph 3.10.5)

3.10.6 Clock (One Microsecond)

Press S2 key followed by C key to automatically call up timing menu and activate clock field. Now press SLOWER or FASTER key and set clock to one microsecond.

3.10.7 Collect

Hold probe tip at junction of resistor and capacitor on A side of test card (test point labeled WF) and press COLLECT. Remove probe.

NOTE

A baseline in waveform display is not present if COLLECT key is pressed when this option is not installed.

To view entire 1000-sample data collection, with X1 magnification selected, waveform should be as shown in Figure 6-42. Use other magnification keys and WINDOW and CURSOR keys to examine collected data in detail and to make timing and voltage measurements. Return to a 1X magnification.

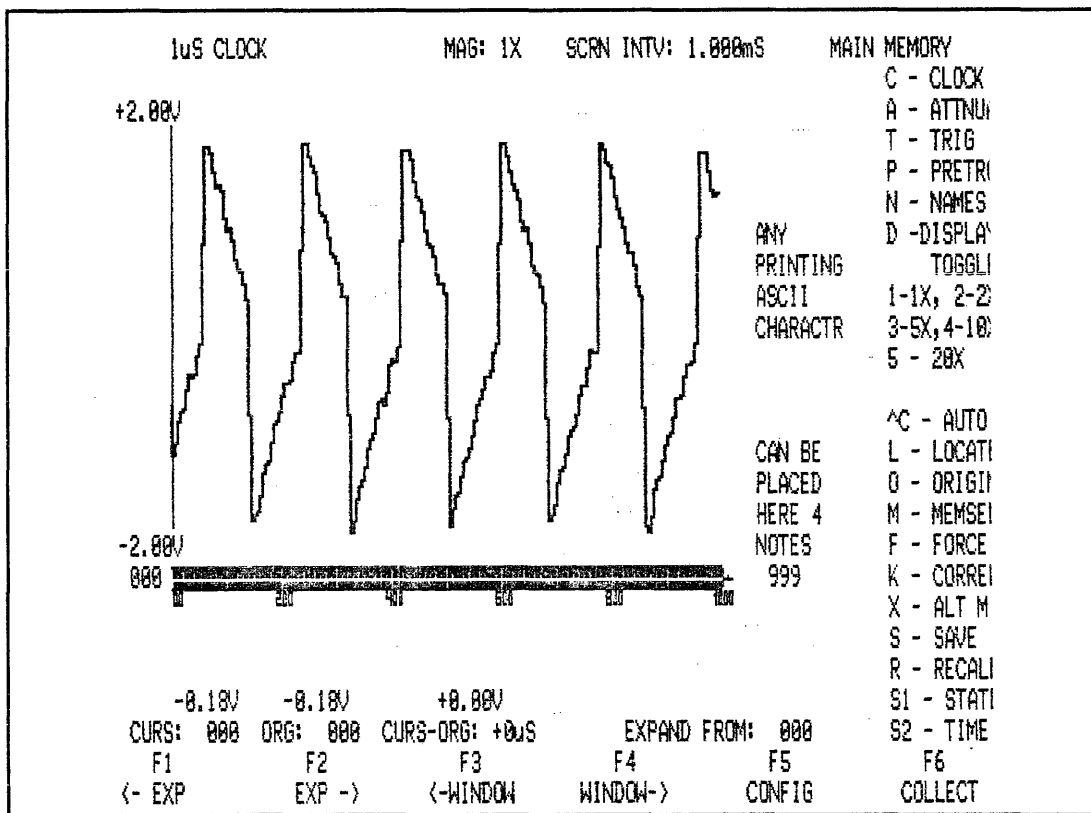

Figure 3-62. Waveform Display at 1X Magnification

3.10.8 Waveform Display (1000 Words, 50 MHz)

3.10.9 Explanation of Waveform Display

Press D key once for unconnected, software interpreted values. Press D key a second time for raw sample points. Press D key a third time to return to a software-smoothed display.

Line 1: Displays internal (or external) clock sampling interval, magnification factor, screen interval, and MAIN/AUX memory.

Line 3: Displays most positive voltage of measurement window at left.

Line 17: Displays most negative voltage of measurement window at left.

Line 18: Displays inverse video graticule which shows range and position (relative to entire 1000-sample data collection) of current display. Trigger point is intensified.

Line 22: Displays voltage at cursor, voltage at origin, and voltage difference between cursor and origin (measurement accuracy is plus or minus approximately three percent).

Line 23: Displays current location of cursor, current location of origin, difference in time between cursor and origin values (for time measurement), and expansion reference location.

NOTE

Expansion symbol, E, used in timing display, is not available in waveform display. However, EXPAND FROM: indicator is still valid.

Lines 2-23: Direct entry and display manipulation keys.

Lines 24 and 25: Soft-key identifiers and labels.

Lines 7-17: Text which can be entered by the user to describe collected data. Use N key, as with timing diagram labeling. Any alphanumeric or ASCII character is permitted in this area, maximum of 8 per line.

3.10.10 Auto-Trigger

In above example, waveform analyzer was in Auto-Trigger mode. That is, the one microsecond clock begins sampling the analog signal as soon as COLLECT key is pressed, without regard to trigger level and signal slope. This free-running mode can be inhibited by setting ARM or TRIGGER linkage field, in timing menu, to W. In this manner, only incoming analog signals that meet the triggering conditions of the waveform menu are collected.

**3.10.11 Advanced Waveform
(Examples, Optional Waveform Board Must Be Installed)***

In this section, the optional waveform analyzer is used to monitor the composite video signal coming from the video BNC connector of the NPC-800C. In addition, to illustrate the "single-shot" storage capability of the waveform analyzer, the LINKAGE field in the timing menu is set to W.

3.10.12 Waveform Mode

Press RESET and select WAVEFORM RECORDER mode when CONFIGURATION LIST appears.

* A baseline in the waveform display is not present if COLLECT key is pressed when Waveform option is not installed.

WAVEFORM ANALYZER MENU					
PROBE TYPE:	AC	INPUT COUPLING:	AC		
VERTICAL ATTENUATION:	200mV	/DIV			
DYNAMIC RANGE:	-2.56V	TO +1.28V			
TRIGGER LEVEL (0-100% OF SCREEN):	50%	= +0.48V			
TRIGGER SLOPE:	↓				
CLOCK:	1uS				
USE TIMING MENU TO SELECT CLOCK, TRIGGER MODE & LINKAGE					
SET ARM OR TRIGGER LINKAGE TO "W" FOR NON-AUTO-TRIGGER					
TIMING CHANNEL A TRIGGER & ARM WILL BE SET TO DON'T CARE IN COLLECTION					
F1	F2	F3	F4	F5	F6
PREVIOUS	NEXT	INCR	DECR	CONFIG	COLLECT

Figure 3-63. Waveform Menu For Monitoring NPC-800C's Video Signal

3.10.13 CLOCK (100 Nanoseconds)

Press S2 key followed by C key to call timing menu with cursor at clock field. Use a 100-nanosecond sample clock.

3.10.14 Single-Shot Mode (W)

Use NEXT key to step to TRIG LINKAGE field. Then use the SELECT key to enter a W into this field. Use NEXT key again to step down to PRETRIGGER field. Press the F3 or F4 key to increment or decrement the pretrigger value of 00 percent (see Figure 3-64).

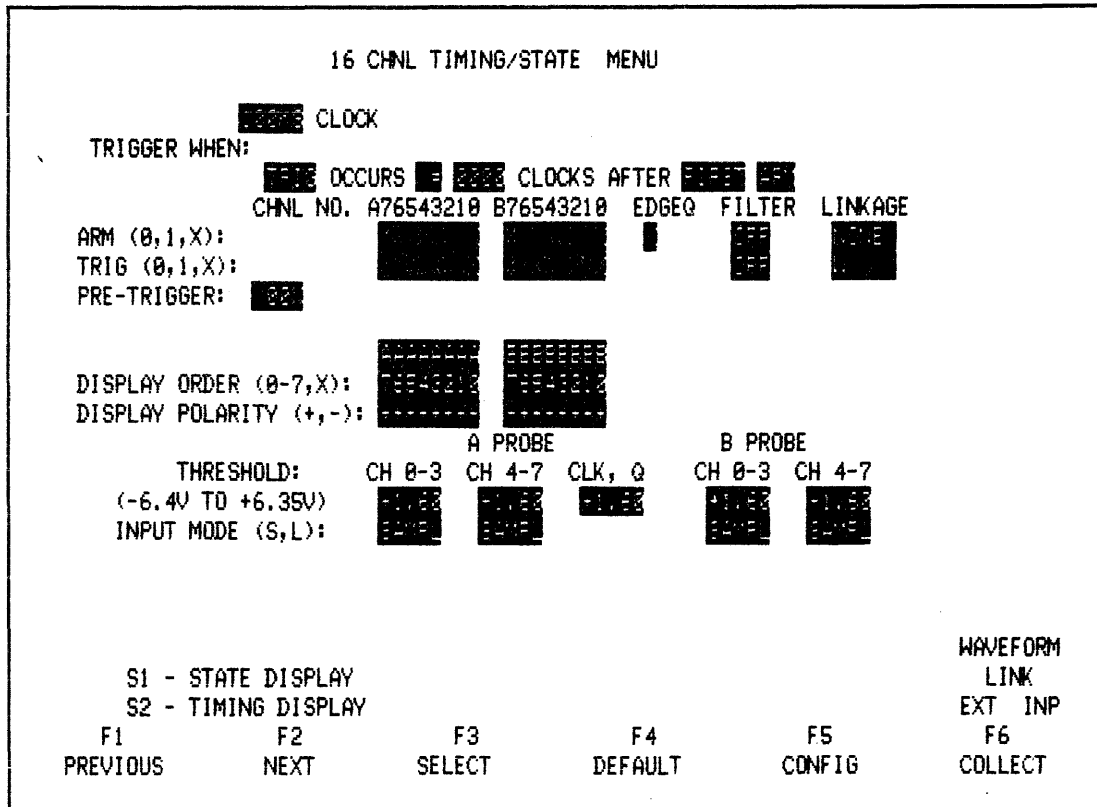

Figure 3-64. Timing Menu Set-Up for Waveform (Example)

3.10.15 No Input Signal

In the NPC-800C, the timing menu is used to set up the waveform sample period and linkage. Setting a W into the LINKAGE field means that all triggering conditions associated with waveform menu (such as threshold and slope) must be satisfied by the incoming analog signal to be able to trigger the analyzer. Make certain that the Model 90 probe is set to X10. Plug it into rear BNC connector labeled WAVEFORM. With ground clip attached to body of any rear BNC connector, and Model 90 probe tip unconnected, press COLLECT. Notice that waveform display is blank and status message ARMED flashes on CRT. This means that the W (or linkage) conditions are not being satisfied, so the waveform analyzer is inhibited from triggering.

3.10.16 Video Input

Insert probe tip into rear BNC connector labeled VIDEO. Then press COLLECT key to get a "clean" data collection. At 1X magnification, display should look approximately as shown in Figure 3-65. The negative-going pulse after the video pulse group is the horizontal sync pulse.

NOTE

Since video signal levels can vary from unit-to-unit, you may have to adjust waveform menu settings slightly to match Figure 3-65.)

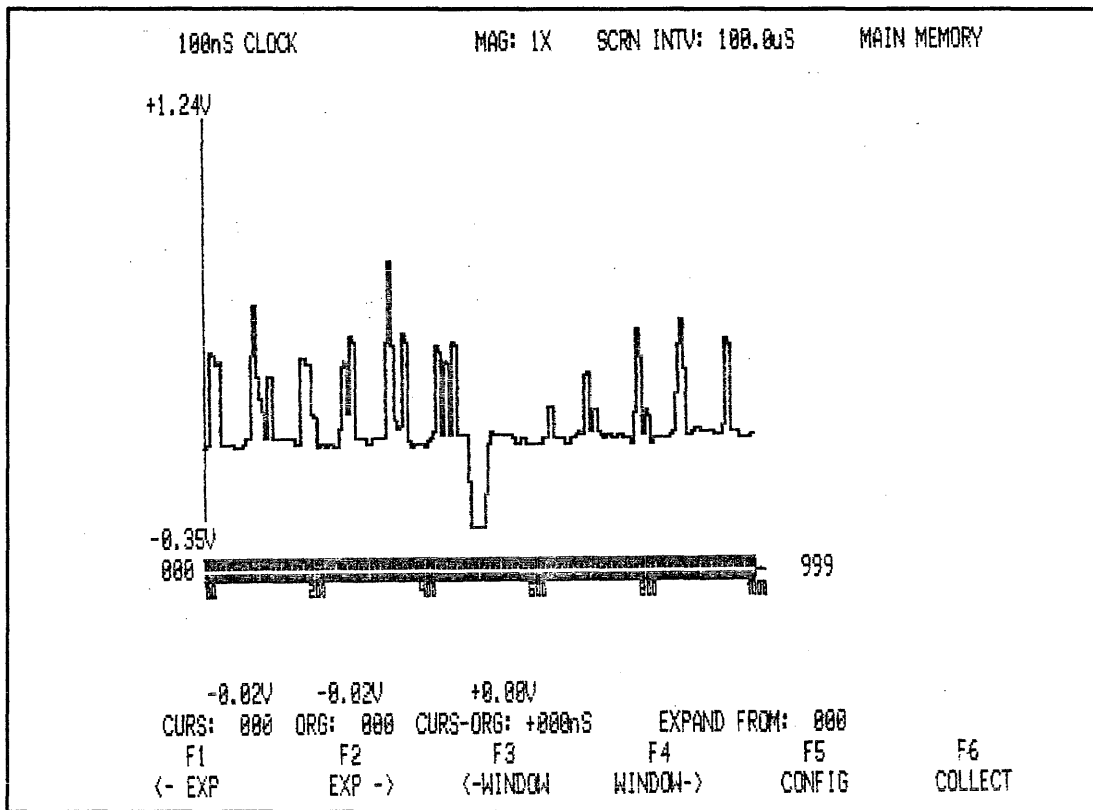

Figure 3-65. Video Signal At 1X Magnification

3.10.17 Expand

Press X2 (2), X5 (3), X10 (4), X20 (5) keys to view video signal at different magnification factors. Return to X1 magnification and press EXPAND key until EXPAND FROM indicator at lower-right corner of CRT corresponds to approximate position in memory of sync pulse (no E symbol is used in the waveform display). Then press X10 (4) key. Next press WINDOW or keys as required to center sync pulse (see Figure 3-66).

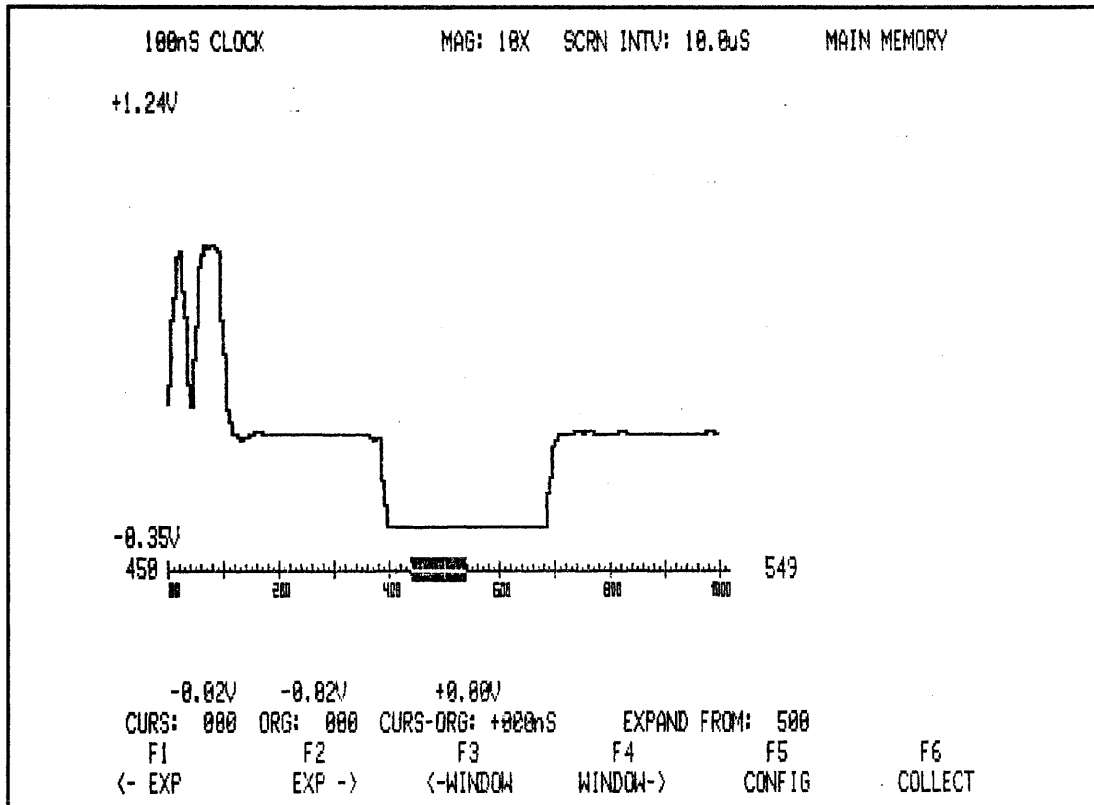

Figure 3-66. Examining Sync Pulse At X10 Magnification

Return to 1X magnification and use EXPAND key to return EXPAND FROM indicator to 000. Then press X20 key to again view any video pulse group at X20 magnification.

3.10.18 Waveform Display Magnification Concepts

X1 - For this magnification factor, each point of the waveform display represents five samples of data in the timing memory. Software takes the first valid sample (i.e., the fourth sample), then scans subsequent sets of five samples each, choosing samples with largest deviation from last point displayed. This procedure continues until 997 samples in memory are processed.

X2 - For X2 magnification, the display process is similar to X1 magnification, except that only 500 samples of timing memory are scanned in alternating groups of two and three samples.

X5 - Here, 200 samples of the timing memory are used to display 200 waveform points on the screen. A filtering algorithm is used to smooth data at X5 and higher magnifications.

X10 - Here, 100 samples of timing memory are used to generate 200 waveform points on the display. Interpolated points are calculated by a linear interpolation algorithm. Furthermore, the filtering algorithm mentioned previously is also used.

X20 - Here, 50 samples of timing memory are used to generate 200 points of waveform data. Each timing sample stored in memory generates four points on the display. A linear interpolation method is used for the interpolated points; then it is smoothed by the filtering algorithm.

3.10.19 Save (S)

Press SAVE (S) key to store waveform and menu in the auxiliary memory. Then press COMPARE (X) key to compare main and auxiliary memories. Return to main memory by pressing MEMSEL (M) key as required. Next press COLLECT to take another data collection. Use X key to compare new collection with reference collection (there should be differences in both amplitude and time). Figure 3-67 shows screens for Main and Aux memories, (notice difference in waveforms). Your example will probably differ.

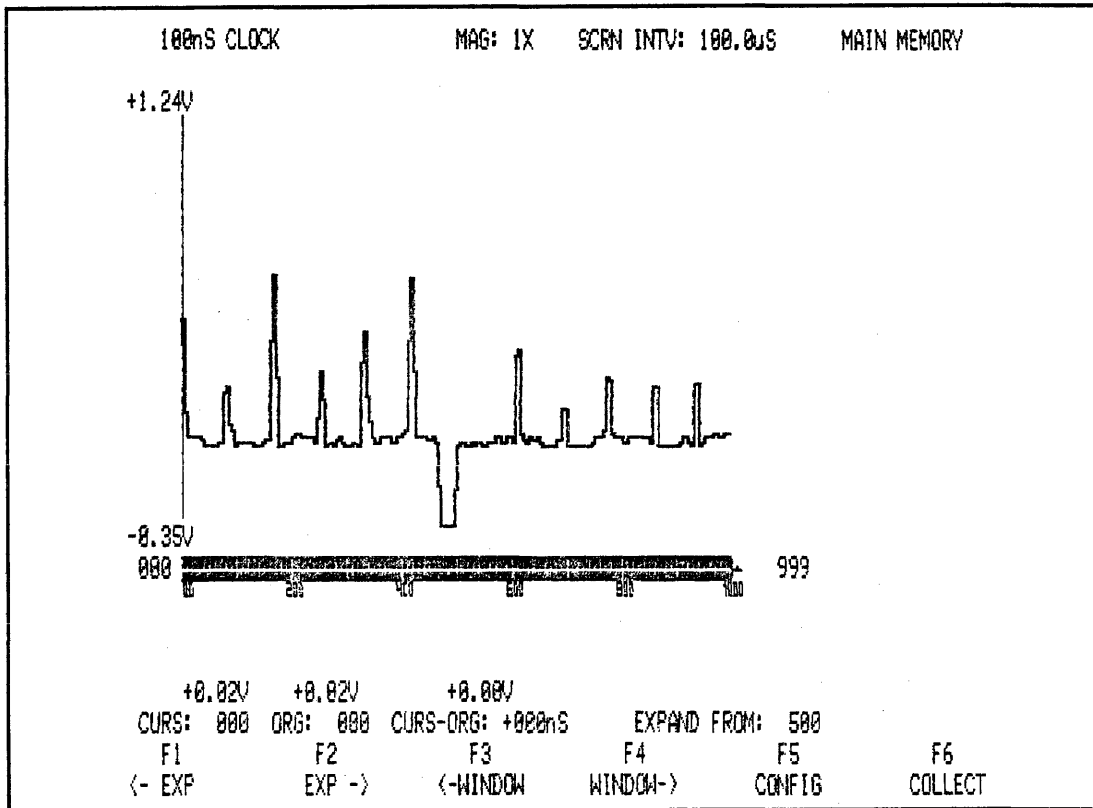

Figure 3-67A. Main Memory Displays

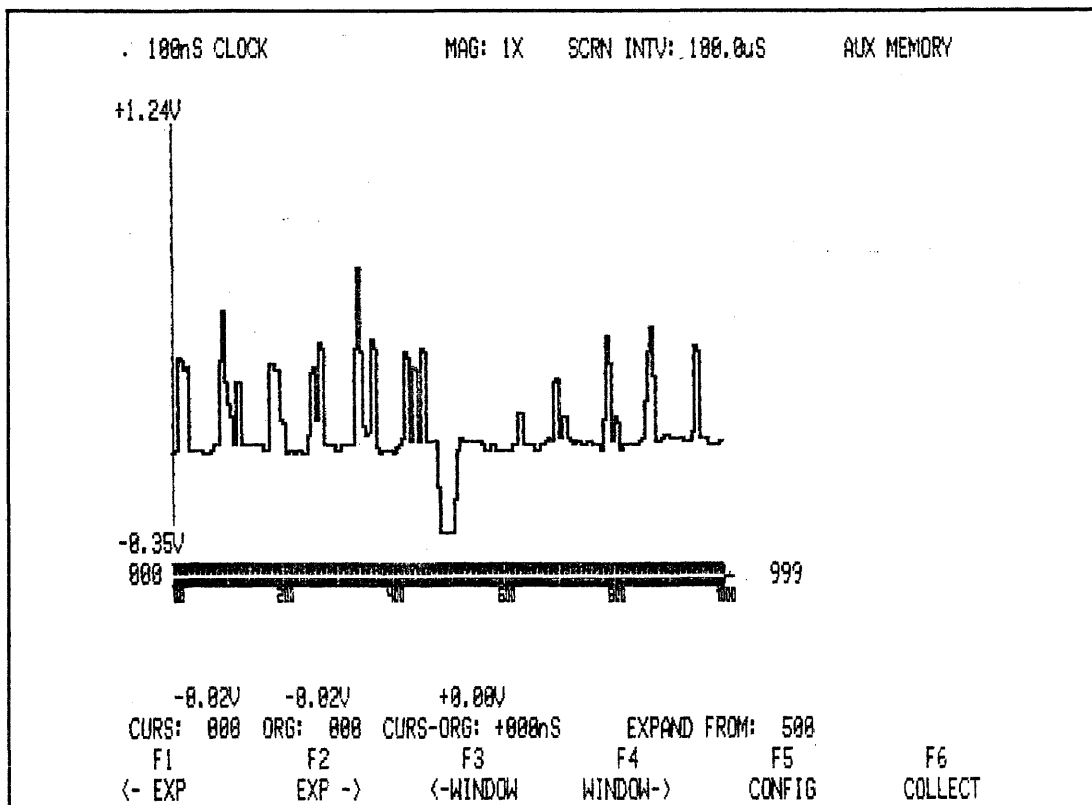

Figure 3-67B. Auxiliary Memory Displays

3.10.20 Correlation (K) (Change Clock Speed to 100 Milliseconds)

Press SAVE (S) key and observe flashing SAVED message. Press K (CORREL) key to compare main and auxiliary data. A correlation factor of 1,000 is displayed at the right of each channel. This factor means that all 1000 bits associated with each main memory channel compares with the 1000 bits in the corresponding auxiliary memory channel on a bit-for-bit basis (see Figure 3-34). Thus, if a correlation factor for .995 were displayed, it would indicate that 5 bits out of 1000 were different.

NOTE

When the K key is pressed, correlation factors replace NAMES. To restore NAMES, press S2.

3.10.21 Measurements

Locate cursor by pressing L key. Experiment with making voltage and time measurements in the main and auxiliary memories using the cursor. ORIGIN (O) key can be used here to relocate origin from 000 to any cursor location.

3.10.22 Aliasing

Because of an insufficient sample rate (below Nyquist limit), aliasing occurs when a high frequency waveform appears on the display as a low frequency waveform.

To avoid aliasing, as a conservative rule of thumb, always sample at 5 to 10 times faster than highest frequency component of incoming waveform.

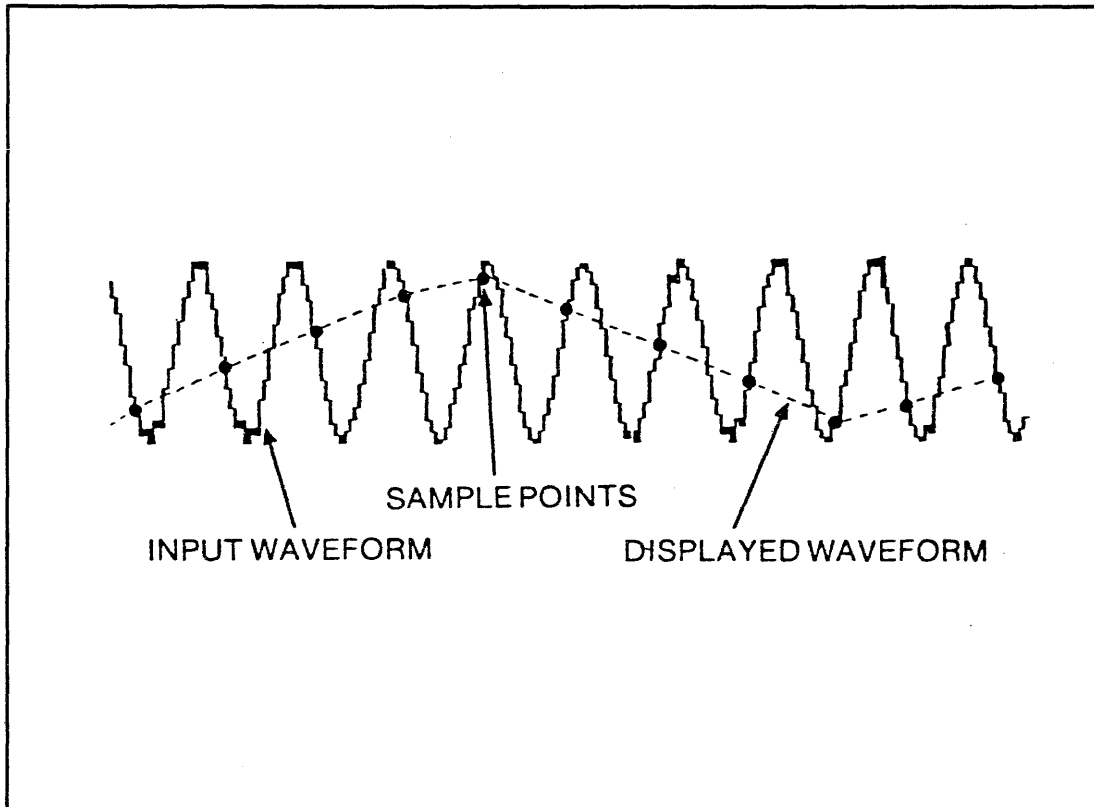

Figure 3-68. Aliasing High Frequency Waveform Displayed as a Low Frequency "Alias"

3.10.23 State Version Of Waveform Display

3.10.24 To Call Display

1. Press COLLECT key to perform data collection.
2. Or if data have been collected, press S1 key.
3. Press BIN (N) key.

MAIN	+007	00011110	11101000
	+008	00011110	11101000
LOC: +007	+009	00011101	11101000
	+010	00011111	11101000
SIG: AC5B	+011	00111001	11101000
943F	+012	00111110	11101000
	+013	00111100	11101000
	+014	00110100	11101000
	+015	00011100	11101000
	+016	00011111	11101000
	+017	00011101	11101000
	+018	00011101	11101000
	+019	00011101	11101000
	+020	00011101	11101000
	+021	00011101	11101000
	+022	00011101	11101000
	+023	00111000	11101000
	+024	00111110	11101000
	+025	00111100	11101000
	+026	00100000	11101000
	+027	00011101	11101000
	+028	00011111	11101000
	+029	00011110	11101000

Figure 3-69. Binary Values of Waveform Samples

3.10.25 Explanation of State Version of Waveform Display

The state version of the waveform display is similar to the 16-channel state display. However, for the waveform analyzer, binary words represent instantaneous voltage values at sample points of incoming analog signal (since waveform analyzer uses a 6-bit a/d converter, the two MSB's in the 8-bit display are always 0).

3.11 WAVEFORM AND STATE ANALYSIS

This section demonstrates the analog waveform recorder and the state analyzer used simultaneously. There are two ways to use both features. First, while collecting both state and waveform information, the waveform recorder can trigger the state analyzer. Second, while collecting both state and waveform information, the state analyzer can enable the waveform recorder.

To demonstrate the waveform recorder triggering the state analyzer, press RESET, which initializes the instrument. Then select (from the Configuration list) State/Waveform mode. Set up Waveform menu as in Figure 3-70. Notice that the "1" set into the last trigger bit of the state analyzer causes the state analyzer to wait for the occurrence of the waveform trigger conditions before it continues through the state trigger sequence, (Timing and State menus are shown in Figure 3-71 and 3-72).

WAVEFORM ANALYZER MENU

PROBE TYPE: AC INPUT COUPLING: DC

VERTICAL ATTENUATION: 10 /DIV

DYNAMIC RANGE: -64.4V TO +64.4V

TRIGGER LEVEL (0-100% OF SCREEN): 50% = +24.4V

TRIGGER SLOPE: \downarrow

CLOCK: 1 μ S

USE TIMING MENU TO SELECT CLOCK, TRIGGER MODE & LINKAGE

SET ARM OR TRIGGER LINKAGE TO "W" FOR NON-AUTO-TRIGGER

TIMING CHANNEL A TRIGGER & ARM WILL BE SET TO DON'T CARE
IN COLLECTION

F1	F2	F3	F4	F5	F6
PREVIOUS	NEXT	INCR	DECR	CONFIG	COLLECT

Figure 3-70. Waveform Menu

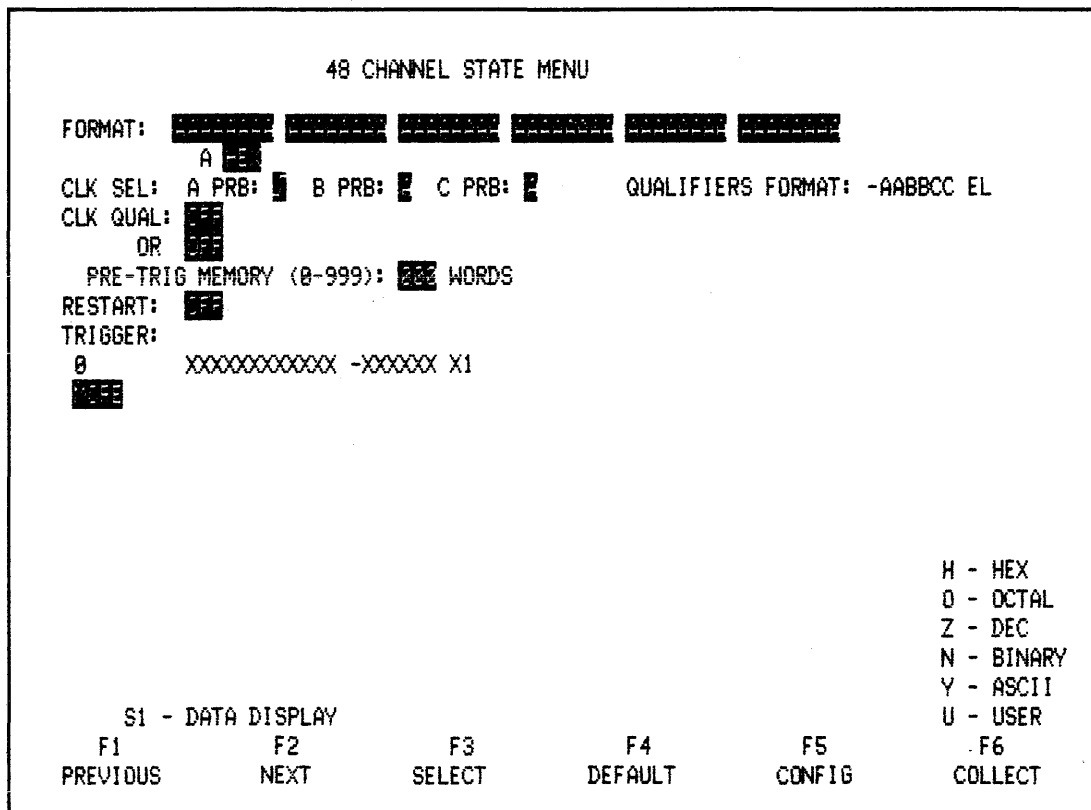

Figure 3-72. State Menu

Attach test card to state probes A & B. Then attach the Model 90 probe to the waveform input on back panel of NPC-800C. Press COLLECT.

The state analyzer progresses through its trigger stack in sequence, until reaching level 2, where it waits for the “link” from the waveform recorder. To allow the waveform recorder to recognize its trigger conditions, insert tip of waveform probe into “VIDEO” output BNC on back panel. The analog signal source for triggering is accessed. Once the waveform recorder has triggered, it enables the state analyzer to continue through its trigger sequence and complete data collection (see Figures 3-73 and 3-74).

MAIN	TRIG	004D800DFFFF
	+001	004E700EFFFF
LOC: TRIG	+002	004FF00FFFFF
	+003	00500010FFFF
SIG: CIAF	+004	00518011FFFF
COAF	+005	00524012FFFF
D0D3	+006	0053C013FFFF
	+007	00542014FFFF
	+008	0055A015FFFF
	+009	00566016FFFF
	+010	0057E017FFFF
	+011	00581018FFFF
	+012	00599019FFFF
	+013	005A501AFFFF
	+014	005B001BFFFF
	+015	005C301CFFFF
	+016	005D001DFFFF
	+017	005E701EFFFF
	+018	005FF01FFFFF
	+019	00600420FFFF
	+020	00618421FFFF
	+021	00624422FFFF
	+022	0063C423FFFF

Figure 3-73. State Data Collection

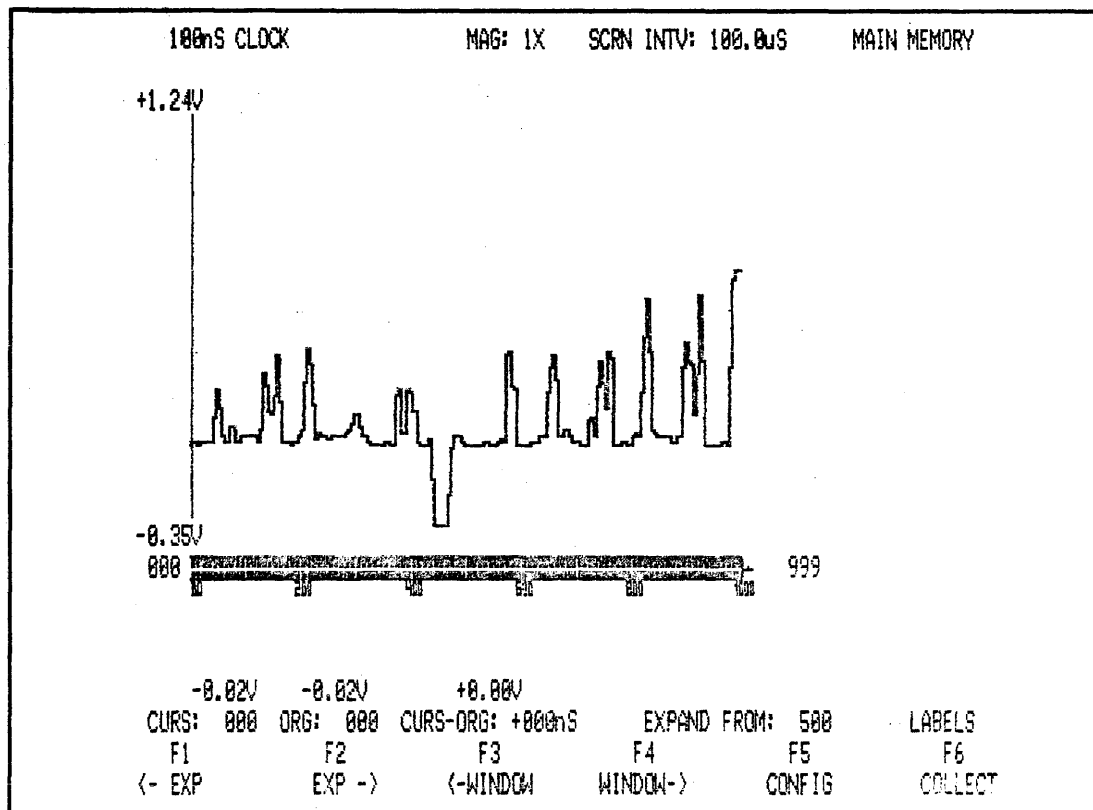

Figure 3-74. Waveform Data Collection

To use the state analyzer to enable the waveform recorder, change State menu to that shown in Figure 3-75, and Timing menu to that shown in Figure 3-76. To allow waveform recorder to recognize its trigger conditions, again insert tip of waveform probe into "VIDEO" output BNC on back panel. To inhibit trigger word specified in trigger level 2, short-out data bit 0 on A side of test card. Press COLLECT.

```

                                48 CHANNEL STATE MENU

FORMAT: ██████████ ██████████ ██████████ ██████████ ██████████ ██████████
        A ██████
CLK SEL: A PRB: █ B PRB: █ C PRB: █      QUALIFIERS FORMAT: -AABBCC EL
CLK QUAL: ██████
        OR ██████
PRE-TRIG MEMORY (0-999): █████ WORDS
RESTART: ██████
TRIGGER:
0        0000XXXXXXXX -XXXXXX XX
1 THEN  0005XXXXXXXX -XXXXXX XX      AFTER 5000 CLOCKS
2 THEN  0048XXXXXXXX -XXXXXX XX      AFTER 3000 CLOCKS
██████

                                                    H - HEX
                                                    O - OCTAL
                                                    Z - DEC
                                                    N - BINARY
                                                    Y - ASCII
                                                    U - USER

S1 - DATA DISPLAY
F1      F2      F3      F4      F5      F6
PREVIOUS NEXT  SELECT  DEFAULT CONFIG COLLECT
    
```

Figure 3-75. State Menu

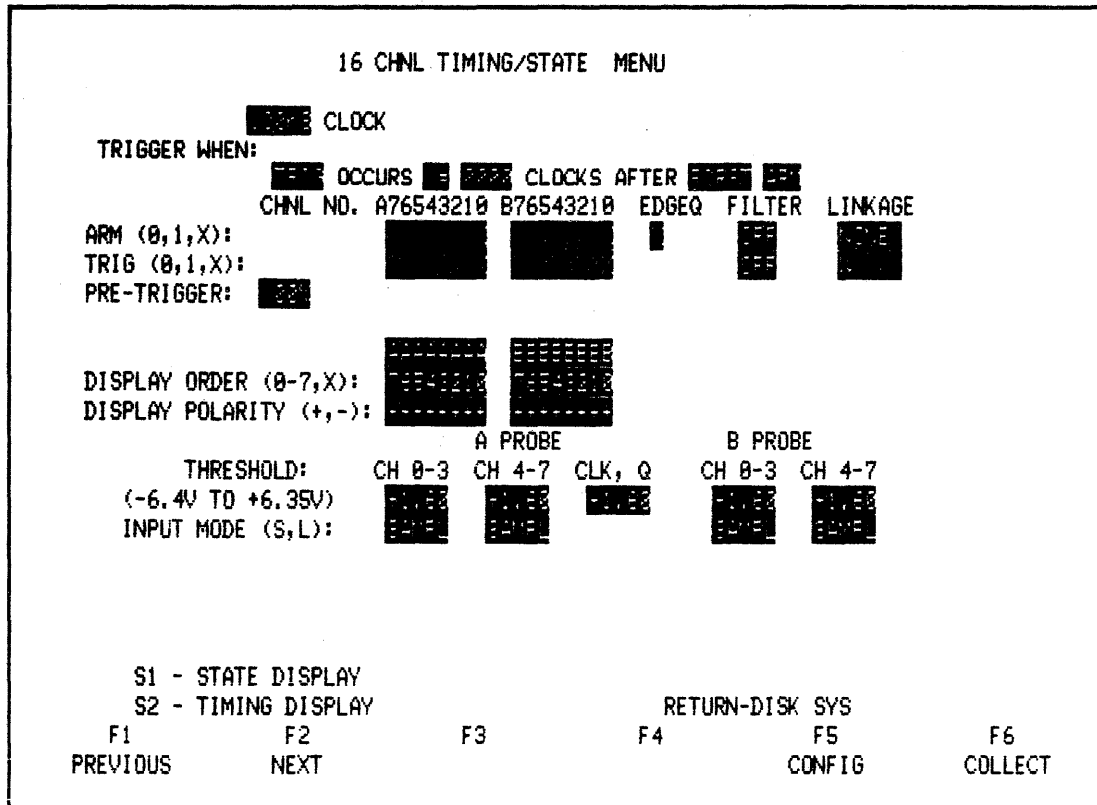

Figure 3-77. Timing Menu

```

      WAVEFORM ANALYZER MENU

PROBE TYPE:  [ 02 ]      INPUT COUPLING:  [ 0 ]
VERTICAL ATTENUATION:  [ 200 ] /DIV
DYNAMIC RANGE:  [ -2.50 ] TO +1.00V
TRIGGER LEVEL (0-100% OF SCREEN):  [ 32 ] = +0.84V
TRIGGER SLOPE:  [ 1 ]
CLOCK:  100ns

USE TIMING MENU TO SELECT CLOCK, TRIGGER MODE & LINKAGE
SET ARM OR TRIGGER LINKAGE TO "W" FOR NON-AUTO-TRIGGER
TIMING CHANNEL A TRIGGER & ARM WILL BE SET TO DON'T CARE
IN COLLECTION

      RETURN-DISK SYS
F1          F2          F3          F4          F5          F6
PREVIOUS   NEXT       INCR       DECR       CONFIG     COLLECT

```

Figure 3-78. Waveform Menu

Connect test card to timing probes and press COLLECT. Timing is now ARM'ed, waiting for waveform "link". Again, to allow waveform to trigger, insert waveform probe tip into "VIDEO" BNC on back panel. This allows timing analyzer to trigger and collect timing data.

3.13 WAVEFORM AND STATE AND TIMING ANALYSIS

The following example demonstrates the simultaneous use of the analog waveform recorder, the state analyzer, and the timing analyzer. It shows the waveform recorder arming the timing analyzer, the state analyzer enabling the timing trigger word to be recognized, and the collection of state and timing data.

Press RESET to initialize instrument. Select WAVEFORM mode to set up Waveform menu as shown in Figure 3-79. Then, to set up the state and timing menus, select STATE/TIMING mode as shown in Figures 3-80, and 3-81. Attach A state probe to A side of test card, and A timing probe to B side the test card. Short out data bit 0 on A side of test card.

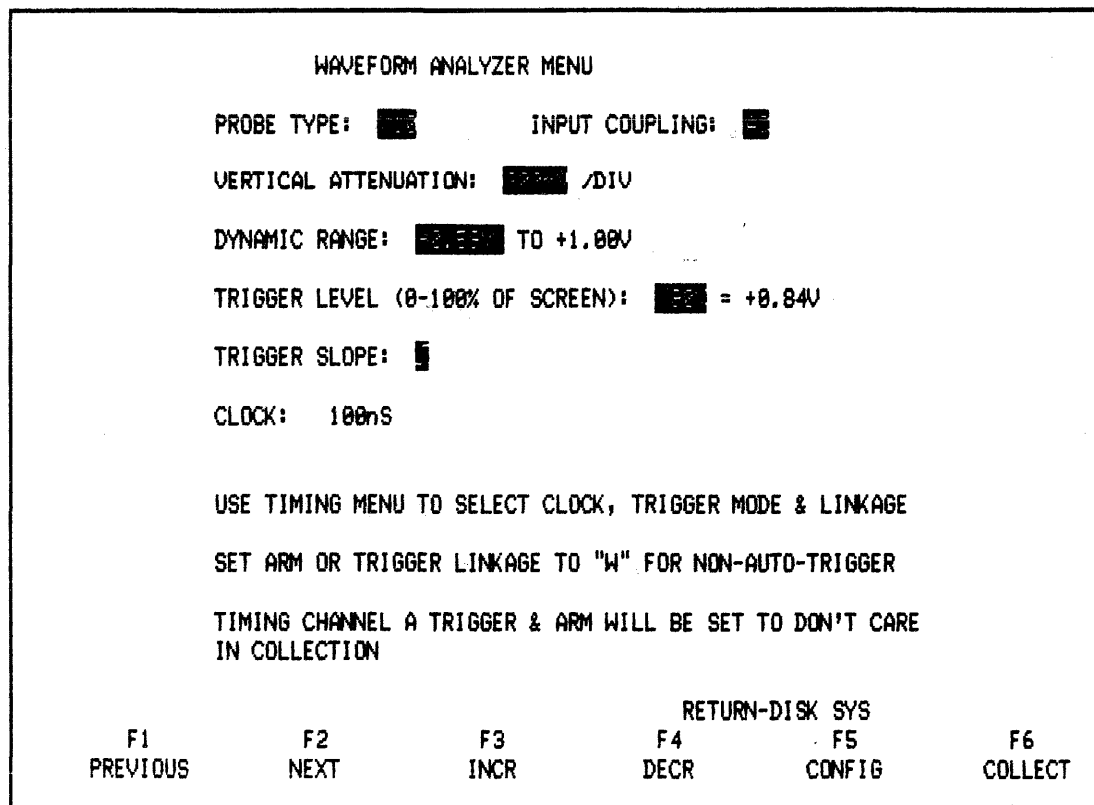

Figure 3-79. Waveform Menu

```

          48 CHANNEL STATE MENU

FORMAT: 00000000 00000000 00000000 00000000 00000000 00000000
        A 00
CLK SEL: A PRB: 0 B PRB: 0 C PRB: 0 QUALIFIERS FORMAT: -ABBCC EL
CLK QUAL: 000
        OR 000
PRE-TRIG MEMORY (0-999): 000 WORDS
RESTART: 000
TRIGGER:
0      0000XXXXXXXX -XXXXXX XX
1 THEN 0005XXXXXXXX -XXXXXX XX      AFTER 5000 CLOCKS
2 THEN 0048XXXXXXXX -XXXXXX XX      AFTER 3000 CLOCKS
0000

                                                    H - HEX
                                                    D - OCTAL
                                                    Z - DEC
                                                    N - BINARY
                                                    Y - ASCII
                                                    U - USER

S1 - DATA DISPLAY      RETURN-DISK SYS
F1      F2      F3      F4      F5      F6
PREVIOUS      NEXT      SELECT      DEFAULT      CONFIG      COLLECT
    
```

Figure 3-80. State Menu

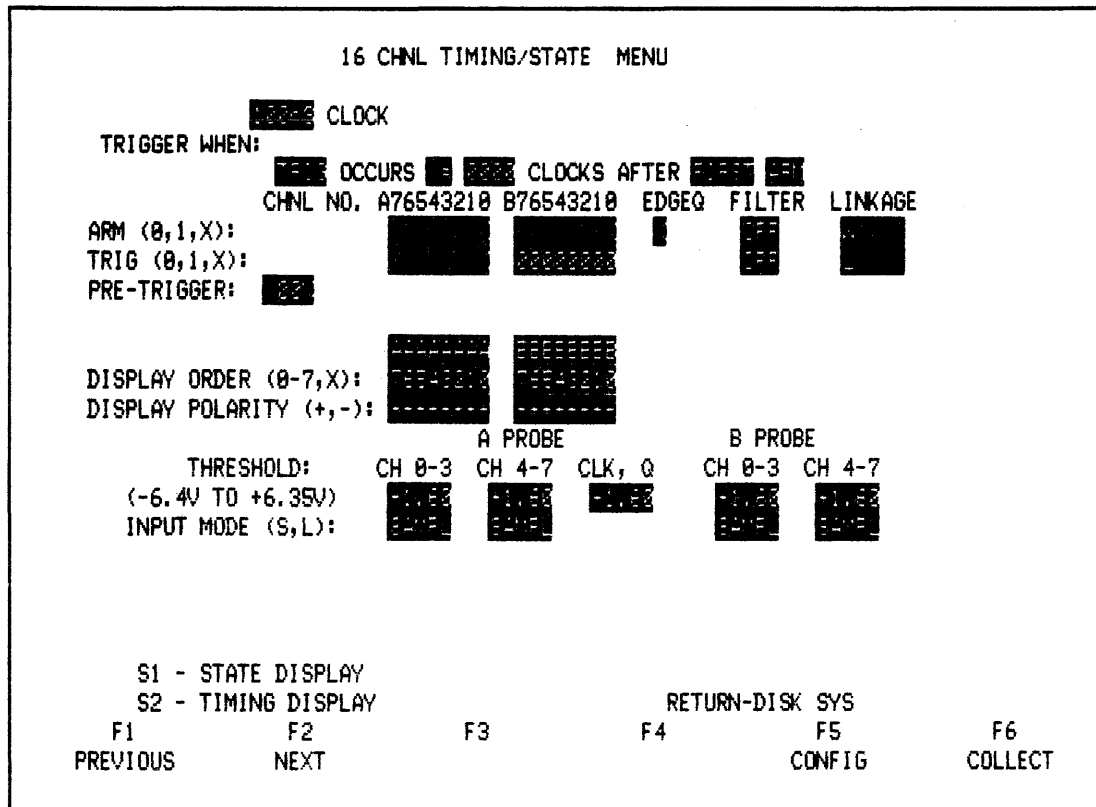

Figure 3-81. Timing Menu

Press COLLECT. State analyzer progresses to level two and waits for trigger word that has been temporarily inhibited. Timing analyzer continues to sample, waiting to be armed. Now insert waveform probe tip into "VIDEO" BNC. This allows waveform recorder to recognize its trigger conditions, which, in turn ARM's the timing analyzer. Because the state analyzer has not yet recognized all of its trigger conditions, the timing analyzer is still not triggered. Remove short (from the test card) on data bit 0. This allows the state trigger sequence to complete, the timing analyzer to TRIGGER, and both the state and timing analyzers to collect data.

There are many other possible linkage combinations which can be setup. Experiment with this feature. These combinations are useful in isolating complex system problems.

3.14 NONVOLATILE MEMORY

The following describes how to store data sets and their associated menu setups in the Nonvolatile Memory option. There are many types of nonvolatile memory currently available. The most popular are battery-backed-up RAM, EPROM, EEPROM, bubble memory, tape drives, and disk drives. Each technique has its own advantages and disadvantages. Because of its speed, relatively low cost, and the benefits it provides when used with the Computer/Controller option, Nicolet Paratronics picked the disk drive technique.

The Nonvolatile Memory option comes with a diskette that has a "Secondary Configuration menu" on it (see Figure 3-82). When the Secondary Configuration menu has been loaded from the diskette into RAM, it provides the user with the ability to easily Save and Recall data

sets and setups. It also allows the user to select from many bus or microprocessor disassembly programs to display mnemonic data.

```

  NTC  NICOLET PARATRONICS CORPORATION
        SECONDARY CONFIGURATION MENU (VER 1.E)

  1 - LOGIC ANALYZER "RECALL"
  2 - LOGIC ANALYZER "SAVE"
  3 - DISASSEMBLER NONE
  4 - EVENT HISTOGRAM MENU
  5 - TIME INTERVAL HISTOGRAM MENU
  6 - USER APPLICATIONS PACKAGE

  ESC - INITIALIZE DISK SYSTEM
  ^P - PRINT SCREEN ON EPSON PRINTER

  F1      F2      F3      F4      F5
ENTER NAME  CONFIG  SEL DOWN  SEL UP

```

Figure 3-82. Secondary Configuration Menu

To save a data set, move cursor to SAVE. Type in desired file name.

The file name can consist of only alphabetic characters, to a maximum of seven.

A file type (to three characters), after the required period delimiter, can be added.

If storage to the optional B drive is desired, the entire file name should be prefixed with B: (B and a colon, without spaces).

Press soft-key F1 to execute save function.

To recall data set or setup, select menu's RECALL line. Type in name of file to recall from the diskette (which obviously must have been saved previously).

3.15 PERFORMANCE ANALYSIS HISTOGRAMS

This option requires the installation of the Nonvolatile Memory option. It provides insight into the total system performance of the target system, or simply to examine the performance time of a subset of the target system.

For example, to examine the percentage of CPU time that several routines are consuming in

the “target system,” press RESET and select Secondary Configuration menu. Select Event Histogram menu and set it up as shown in Figure 3-83. Attach test card to A and B state probes. Press COLLECT. The state analyzer collects a complete data set. Performance Analysis software then examines data set, extracts information, and then displays statistics of that information in bar-chart format. The state analyzer then collects another set of data. The examination process is repeated, to update the bar-chart display. This process is repeated until you press STOP.

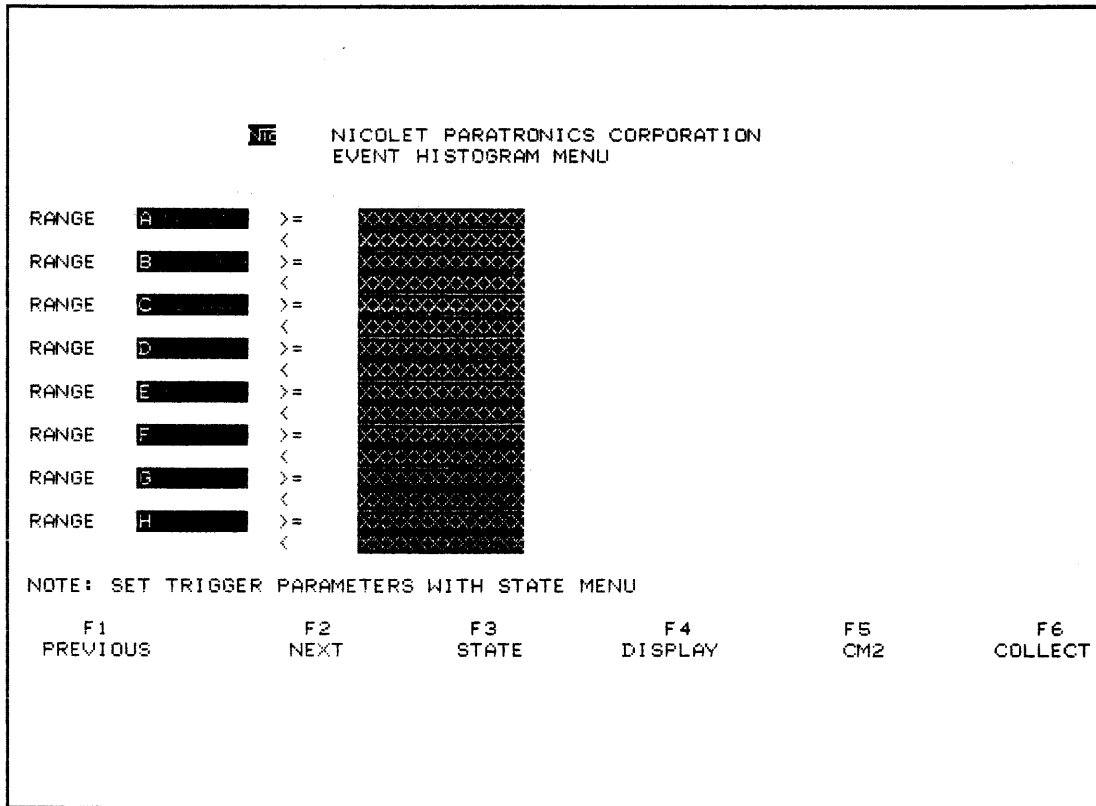

Figure 3-83. Event Histogram Menu

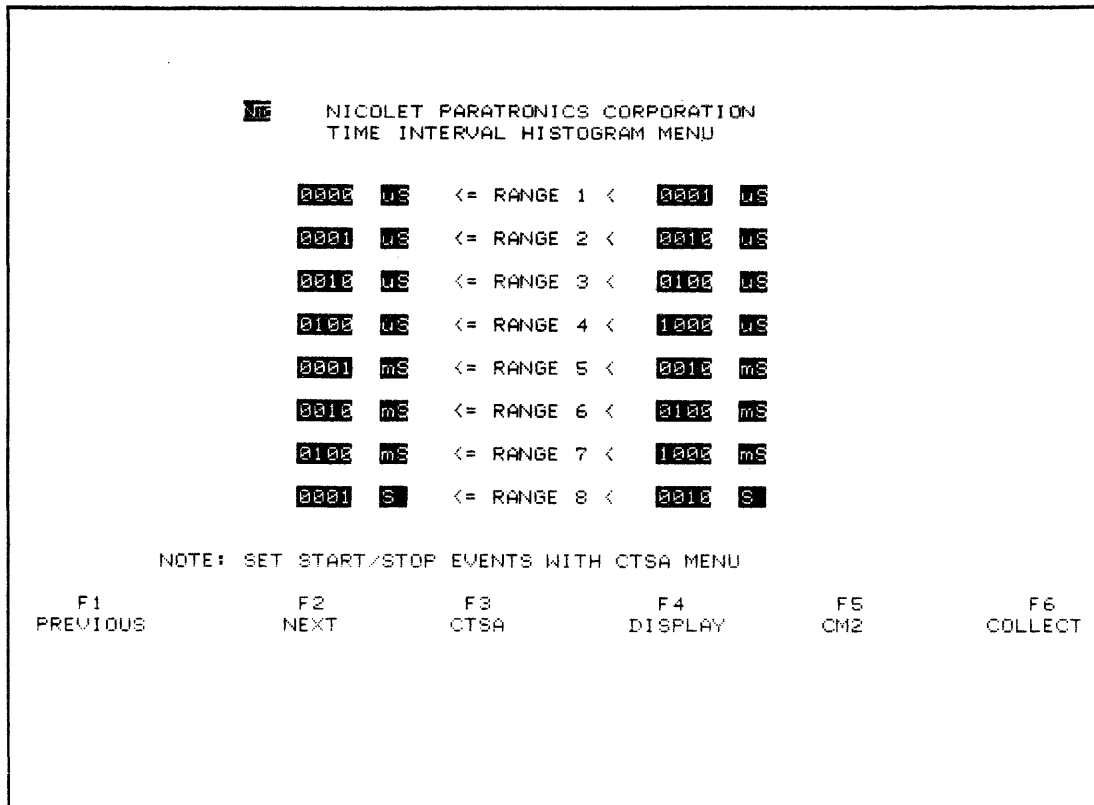

Figure 3-85. Time Interval Histogram Menu

Because hardware is used to “write” the analog waveform on the screen (instead of using characters in the screen memory), the printer will not print the analog waveform display. It prints the axes and measurement information, but not the analog signal display.

3.17 DEDICATED PROBES

3.17.1 Disassembly (Example)

To simplify tracing of a microprocessor’s program, NPC offers dedicated probes with disassembly software for most popular 8-and 16-bit microprocessors.

3.17.2 “Disassembling” The Test Card

Even without a dedicated probe, if you have the nonvolatile memory option installed, you can still “disassemble” data patterns from the test card.

Simply connect A and B state probes to corresponding connectors on test card. Call State menu and set A-channel trigger to 0040.

3.17.3 Collect

Press COLLECT key and display data in hexadecimal or any other desired format.

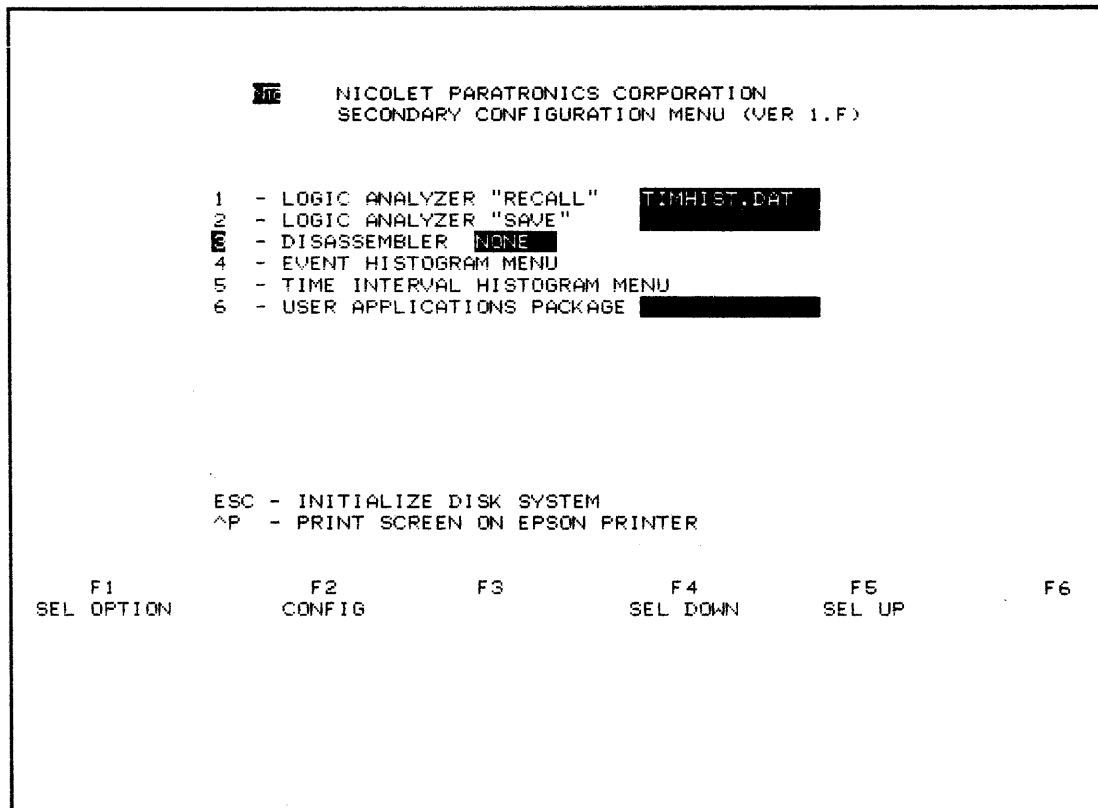

Figure 3-87. Secondary Configuration Menu to Select Disassembly Software

3.17.4 Loading Disassembly Software

Call Secondary Configuration menu and press F4 (Select Down) key to move cursor down to "3 Disassembler." Then use F1 key to select Z80 disassembler. To load to disassembler, press F3 (Load) key. Return to CONFIGURATION LIST by pressing F2 and, using F1 key, return to state analyzer.

3.17.5 Displaying In Disassembled Format

Pressing the 1 key changes the display format to disassembly.

NOTE

Press labels key and observe that 1 is a format option key as are H and 0.

MAIN	TRIG	0040	NOP	
	+001	0041	01	OPERAND FETCH
LOC: TRIG	+002	0042	02	DATA READ
	+003	0043	03	RE
SIG: C1E7	+004	0044	04	INPUT
19E7	+005	0045	05	(C)
D8D3	+006	0046	06	STACK READ
	+007	0047	07	INTERRUPT ACKNOWLEDGE
	+008	0048	DJNZ	005BH
	+009	0049	09	D)
	+010	004A	0A	DATA WRITE
	+011	004B	0B	IM
	+012	004C	0C	OUTPUT
	+013	004D	0D	PORT:
	+014	004E	0E	STACK WRITE
	+015	004F	0F	REFRESH
	+016	0050	DJNZ	0063H
	+017	0051	11	OPERAND FETCH
	+018	0052	12	DATA READ
	+019	0053	13	RE
	+020	0054	14	INPUT
	+021	0055	15	(C)
	+022	0056	16	STACK READ

Figure 3-88. Disassembled Display of Arbitrary Test Card Data (Z80 Disassembler Used)

NOTE

Information in Figure 3-88 is meaningless because neither a dedicated probe nor a real microprocessor were used.

3.17.6 Unused State Channels

Since NPC's 8-bit dedicated probes require 32 channels (A & B), there are 16 additional state channels (C) (and 16 additional timing channels) available for monitoring other signals in your

system. To view these additional state channels, simply type the key corresponding to desired display format (see LABELS field).

3.17.7 User Format (U)

If a mixed format is used, type U to call all 48 channels (A, B, and C) of state data in that format. Then type 1 to again disassemble data associated with A and B probe inputs.

3.17.8 Serial Analyzer

For serial testing, the NPC-800C requires a Model 70 serial probe. With this probe, RECEIVE, EDIT and TRANSMIT functions are possible. In RECEIVE mode, the Model 70 converts incoming serial data to parallel words for collection by the state analyzer. Captured data can be displayed in ASCII or any other available format. To display received data shown in menu in Figure 3-89, transfer collected data from main state memory to auxiliary memory. To do this, press S (SAVE) key after data collection.

EDIT and TRANSMIT modes operate on whatever ASCII characters are in the data field shown in Figure 3-89. Instructions for using these modes are contained in the menu itself. For additional details, consult the Model 70 User's Instructions (available from nearest NPC sales office).

```

                                PI MODEL 70 TRANSMIT

                                1   5   10  15  20  25  30  35  40  45  50
                                ───────────────────────────────────
001 THE QUICK BROWN FOX JUMPS OVER THE LAZY DOG
051 0123456789
101
151
201

CHARACTER COUNT: 250

ENTER DATA IN: E (USE F1 KEY)
SEND DATA BIT 8 AS B (USE F3 KEY)

^L (RIGHT), ^H (LEFT), ^J (DOWN), ^K (UP) TO MOVE CURSOR

S2 - CONTINUOUS XMIT (ANY KEY TO STOP)

SET A CLK TO 1 TO RECEIVE DATA THROUGH THE M70 PROBE
                                RETURN-DISK SYS
F1      F2      F3      F4      F5      F6
BASE   CLEAR   BIT 8   END DATA  CONFIG  XMIT

```

Figure 3-89. Model 70 EDIT and TRANSMIT Menu

NOTE

Cursor commands shown in menu: CTRL L (RIGHT) and CTRL H (LEFT), are used when data entry base is hexadecimal or octal. When data entry base is in ASCII, it's easier to use the SPACEBAR and BACKSPACE keys for simple editing.

3.17.9 Available Dedicated Microprocessor Probes/Disassembly

Call factory for appropriate Application Notes

8080 — Model 55	6800 — Model 57
8085 — Model 56	6802 — Model 57
8086 — Model 59	6808 — Model 57
8088 — Model 65	6809 — Model 62
Z80 — Model 58	6809E — Model 63
6502 — App Note	68000 — Model 64

3.17.10 Available Dedicated Bus Probes

Call factory for appropriate Application Notes.

RS-232C — Model 70
RS-232C/MIL-188C/RS-422/3 — Model 71
IEEE-488 — App Note
DEC UNIBUS — App Note

3.17.11 General Purpose Interface Probe**3.17.12 Nicolet In-circuit Emulators (NICE)**

Z80	— NICE Z80
8085	— NICE 8085
NSC 800	— NICE NSC 800
8088	— NICE 8088

3.18 COMPUTER/CONTROLLER**3.18.1 General-Purpose Computer**

As described in the introduction, the NPC-800C is not only a very capable logic analysis system, it can also be configured to be a general-purpose, desk-top microcomputer. Since the logic analyzer has been thoroughly described in previous sections of this manual, this section deals only with the microcomputer aspects of the NPC-800C.

All microcomputers are comprised of a hardware system and a software system. Unless used for a single, specific task, the software system is called an "operating system." The purpose of an operating system is to provide the interface between the hardware and the user.

3.18.2 Hardware Display

The following are three display techniques available to the user of the NPC-800C. A 9-inch CRT with 25 lines of 80 character positions each for integral display. A BNC connector on the

back panel permits standard RS-170 composite video information from the CRT to also be displayed on an external video monitor or printer. And, for display, an RS-232C interface permits the transmission of information to an external terminal, printer, or another NPC-800C system.

3.18.3 Keyboard

A full ASCII keyboard, familiar to most users, has seven special function keys at the top, plus a RESET key. In the Reset mode, the RESET key calls the Logic Analyzer Operating System (it must be held down for approximately two seconds). This time delay is needed to prevent an accidental reset at an inopportune time. When operating the NPC-800C as a logic analyzer, or user-defined for Microcomputer mode, six other special keys are predefined.

3.18.4 Memory Subsystem

There are 48K bytes of RAM available to the user. Since the NPC-800C's 8085 microprocessor cannot directly address this 48K bytes of RAM and an additional 40K bytes of analyzer ROM, memories are "bank switched," enabling only one memory bank at a time.

3.18.5 Disk Drive

Both integral flexible disk drives are 5¼-inch, double-sided, double-density, soft-sectored, 96 tracks per inch (80 tracks) with 600K bytes of formatted capacity. Refer to Section 2 for diskette specifications. Using an external dual-drive expansion chassis, a connector is provided to expand disk memory to approximately 2 megabytes, unformatted. Using a serial-driven disk subsystem, the RS-232C interface can also be used to extend the disk memory.

3.18.6 I/O

The RS-232C interface on the NPC-800C provides a "standard" interface to serial devices. This bidirectional interface is described in Section 3-20.

3.18.7 Controller

The NPC-800C also incorporates an intelligent controller for the IEEE-488 interface bus. Commands that permit execution of user programs to control an IEEE-488 bus-based system are described in Section 3-19.

3.18.8 Software

As stated previously, an "operating system" is a program designed to provide an interface between the user and the hardware. The NPC-800C actually has two operating systems; the logic analyzer operating system, which is in ROM, and CP/M, which is loaded from disk into RAM (CP/M is a trademark of Digital Research).

The ROM-based operating system for the logic analyzer requires little explanation because the functions of this system are fixed and dedicated to controlling logic analyzer hardware.

In contrast, user interface to the microcomputer cannot be defined specifically because of the great diversity of application software available to be purchased or created by the user. Therefore, a description of CP/M is included.

3.18.9 CP/M

For the 8080, 8085, and the Z80 microprocessors, CP/M is one of the most commonly used operating systems. Reasonably priced programs are available that perform a wide variety of applications, from word processing to scientific data analysis.

Through CP/M, the user can also create his or her own programs. These programs can be machine-code, generated via assembly language by a resident assembler, or they can be generated using a high-level language such as BASIC or FORTRAN. CP/M can also be used to set up and control the analyzer and then post-process analyzer data.

3.18.10 CBASIC

CBASIC is also provided with the computer option. This version of BASIC was chosen because it is easy to use, allows variable names 31 characters long, and eliminates some documentation tasks. It also uses a pseudo-compiler that reduces execution time.

3.18.11 CP/M Overview

This NPC-800C Operator's Manual is intended to guide the user in the application of CP/M, not to provide a tutorial nor to make the user proficient in its use. The following information is an overview of CP/M. It also offers basic examples of some of CP/M's features and commands. For more detailed knowledge of CP/M and its applications and/or modifications, refer to the CP/M Documentation Manual provided with the NPC-800C.

The CP/M operating system is literally a system of interrelated programs. Rather than load all CP/M into memory at once and unnecessarily consume RAM memory space, hardware memory is partitioned such that one section contains the core of the operating system (hereafter referred to simply as "the system"), while the remaining programs reside in an area of memory designated as "transient program area." These transient programs are loaded into shared memory only when needed.

There are two kinds of commands available in CP/M: built-in and transient. Built-in commands are five of the most commonly used commands which are part of the core of the CP/M system and do not appear on the disk directory. Transient commands are so named because they are actually programs that generally appear in the disk directory. When called, they are loaded into the Transient Program Area (TPA) of RAM. After loading into RAM, each transient program has its own set of commands which can be executed.

3.18.12 Built-In Commands

DIR - command used to display the disk directory.

TYPE - used to simply examine a disk source file listing only, by displaying file on the CRT, exactly as it is stored on disk.

SAVE - used to transfer transient program area of RAM memory to disk. Normally this program would be used to save programs generated by ASM.

REN - renames an existing file on the disk. It will not create a new copy of the old file, merely assigns a new name.

ERA - erases an unwanted file from the disk.

*File labeled: READ ME describes other files on diskette. To access this file, type: TYPE READ.ME. Then press CNTL S to stop and any key to resume scrolling.

3.18.13 Transient Commands

SYSGEN - does not appear in the disk directory. Used to generate a new bootable system disk for use as a backup copy. Because of copyright restrictions, CP/M may not be copied.

STAT - displays remaining memory space on disk or displays the size and other characteristics of a specific file.

ED (and associated commands) - performs a simple line-oriented text editor function. It is not a word processor, but a tool to use in creating and editing files. These files can be simple text or high-level programs to be compiled later.

PIP - handles and manipulates the program. Used to copy files, transmit and receive data on the RS-232C interface, and, for file handling, assigns physical devices to logical device names used in PIP.

SUBMIT - Specifies a series of CP/M commands to be executed sequentially. This series can be stored as a file, then called any time the user wishes to perform that series of commands — without having to type them from the keyboard each time.

XSUB - an extended submit program that allows a series of commands to be linked into a file; and which also stops and permits user to insert variable information into specific elements of the command list.

ASM - an assembler program for the 8080/8085. It allows the user to create 8080/8085 executable code using assembly language. This 8080/8085 code thus generated may be used in the NPC-800C or it can be transmitted, using PIP, to an external device, such as a PROM programmer. There are similar programs for other microprocessors available from software suppliers.

DDT - used to debug programs created with ASM. It tests the program and permits editing.

LOAD - used to convert a program from a “.HEX” file created by ASM into an executable “.COM” file. As conversion takes place, the program is loaded into executable memory space.

DUMP - used to display a file from disk in HEX form rather than ASCII.

3.18.14 NPC Transient Commands CM2.COM

3.18.15 Secondary Configuration Menu

Allows the following selection:

1. Time histogram
2. Event histogram

3. Print routine for Epson Series graphics printer on the RS-232 port
4. LASAVE.COM
5. LARECALL.COM
6. Disassemblers
7. Load and execute user supplied subprograms

UC2.COM - sample user program that can be loaded and executed using CM2.COM. Program displays entire NPC-800C character set.

UC2.LST - source listing of sample user program UC2.COM.

D8080 - 8080 microprocessor disassembler software

D8085 - 8085 microprocessor disassembler software

D6800 - 6800 microprocessor disassembler software

D6809 - 6809 microprocessor disassembler software

D6809E - 6809E microprocessor disassembler software

D488IEEE - IEEE-488 disassembler software

D8086 - 8086 microprocessor disassembler software

D8088 - 8088 microprocessor disassembler software

D68000 - 68000 microprocessor disassembler software

DZ80 - Z80 microprocessor disassembler software

FORMAT1.COM - program to format a single-sided diskette for operation on the NPC-800C system; external drives only

FORMAT2.COM - program to format and copy the CP/M operating system on a double-sided diskette on the NPC-800C system

KYBDTEST.COM - program used to test NPC-800C keyboard

LA.COM - program used to return to NPC-800C firmware from CP/M disk operating system without resetting NPC-800C

LASAVE.COM - program used to save NPC-800C set-up and collected data into a disk file

Format - LASAVE D:FILENAME.XXX

LARECALL.COM - program used to recall from diskette the NPC-800C set-up and data stored by the LASAVE program

Format - LARECALL D:FILENAME.XX

LADISA.COM - program used to load a disassembler from diskette for use by logic state analyzer firmware

Format - LADISA D:FILENAME.XX

RAMTEST.COM - program used to test dynamic RAM and state analyzer static auxiliary RAM

3.18.16 Files To Be Executed Using CBASIC Interpreter

GPIBEX.BAS - source code file of an example program that exercises NPC-800C GPIB functions.

GPIBEX.INT - intermediate code file of an example program that exercises NPC-800C GPIB functions.

GPIB.BAS - source file written in BASIC that can be included in a BASIC program to allow high level language access to the GPIB controller and device functions

LADISC.BAS - source file written in BASIC that can be included in a BASIC program to allow the saving and recalling of NPC-800C set-up and data files from a BASIC program

RS232EX.BAS - source code file of an example program that exercises operating system control of the NPC-800C and exercises NPC-800C-to-NPC-800C operation over the RS-232C interface

RS232EX.INT - intermediate code file of an example program that exercises operating system control of the NPC-800C-to-NPC-800C operation over the RS-232C interface

RS232EX.001 - LASAVE file used by RS232EX program

RS232EX.002 - LASAVE file used by RS232EX program

SAVREC.ASM - source file in 8085 assembly used by LADISC.BAS to allow SAVE/RECALL of analyzer data files

SAVREC.COM - COM file of SAVREC.ASM read by LADISC.BAS to perform LASAVE and LARECALL

3.18.17 CB-80, Compiled Basic

Some customers have asked for a language that executes their applications programs faster than CBASIC. CB-80 is faster executing BASIC, but it generally consumes more time during program debug. However, you may purchase the CB-80 compiler and use the following files instead of those for CBASIC.

3.18.18 Files For Compilation By CB-80

GPIBEX80.BAS - source file written in CB-80 of an example program that exercises NPC-800C GPIB functions.

GPIBEX80.REL - relocatable binary file generated from assembling GPIBEX80.BAS

GPIB80.BAS - source file written in CB-80 that can be included in a BASIC program to allow high level language access to GPIB controller and device functions

GPIBPS80.REL - relocatable binary file that is used with the GPIB80.BAS file to allow higher level access to the GPIB controller and device functions. The routine provides call access to absolute addresses from the CB-80 program.

GPIBPS80.MAC - source program for GPIBPS80.REL file. It requires an assembler that generates a relocatable binary file.

LADISC80.BAS - source file written in CB-80 that can be included in a BASIC program to allow the saving and recalling of NPC-800C set-up and data files from a CB-80 program

SAVREC80.MAC - source file used with LADISC80.BAS to allow saving/recalling of NPC-800C analyzer data

SAVREC80.REL - relocatable binary file generated by assembling file SAVREC80.MAC

GPIBEX80.COM - executable file generated by compiling GPIBEX80.BAS BASIC program with CB-80

3.18.19 Use Of LASAVE and LARECALL From a CBASIC Program

A file is provided on floppy disk (named LADISC.BAS) that provides the function definitions necessary to save or recall analyzer set-ups and data while executing a CBASIC program. This information is useful in automated testing. It recalls canned set-ups or "known-good" data and saves the results for later analysis.

To use these functions, first compile a CBASIC test program with LADISC.BAS (included prior to the first program access). This can be done with the CP/M editor or, at compile time, by using the following CBASIC statement:

```
%INCLUDE LADISC
```

To execute LASAVE, use the statement format:

```
RC% = FN.LASAVE% ( filename$ )
```

To execute LARECALL, use the statement format:

```
RC% = FN.LARECALL% ( filename $ )
```

filename \$ is any valid CP/M file name.

RC% contains a return code, as follows:

- 0 = normal execution
- 1 = disc full (save only)
- 2 = no such filename (recall only)
- 3 = invalid filename

3.18.20 CP/M Examples

This is a description of the steps you may need to perform some of the more available, commonly-used commands. Although you will not receive an in-depth knowledge of CP/M and its facilities, the examples that follow show you how to perform basic text file creation, limited file manipulation, 8080/8085 code generation and debug, and how to get a hardcopy of your files. You'll also be able to exercise control over the execution of logic analyzer tests saved on disk.

3.18.21 Power On

If power is already on, it is not necessary to turn power off and back on. Insert CP/M diskette in accordance with Section called CONFIGURATION LIST; press ESC (ESCAPE) key. If power is off, turn it on at rear of right side of unit BEFORE INSERTING DISKETTE.

3.18.22 Header

The system responds with a header identifying the current version of the CP/M operating system. The system also displays a prompt to signify that it is ready for operator input:

A>

DIR

DIR is used to display the disk directory. Simply type DIR and press RETURN:

A>DIR(RETURN)

The CRT should now display the contents of the disk. A identifies disk drive in use. If dual-disk expansion capabilities are used, a B or C is displayed.

3.18.23 STAT

STAT is a transient command used primarily to determine how much DISK MEMORY is remaining, or the size of a particular file.

Type:

STAT (RETURN)

The above command will display the remaining disk memory.

```
stat  
A: R/W. Space: 68k  
  
A>
```

Figure 3-90. Response To Request For Space Status On Disk

Next, type:

STAT RAMTEST.COM (RETURN)

```

st^Qla

Recs Bytes Ext Acc
  8   4k   1 R/W A:RAMTEST.COM
Bytes Remaining On A: 68k

A>

```

Figure 3-91. Using "STAT" Command To Determine Size Of File

This command displays the size of any file using the format: STAT FILENAME.EXT \$\$\$. Select another file from your directory and try this command again.

NOTE

You must enter all commands exactly as shown with all spaces and characters specified; otherwise the NPC-800C responds with a File Not Found or other error message.

3.18.24 ED

Used for the creation of files, ED is a simple implementation of a text editor. These files can be text, or they can be a high-level-language program that is compiled later.

ED has its own set of commands that only operate after ED has been executed. Those commands allow you to create text, edit it, store it on disk, and retrieve it from disk.

For this example, only a small portion of those commands is used. Therefore, it is **IMPERATIVE THAT YOU FOLLOW THIS EXAMPLE PRECISELY**. Otherwise, you may get into a situation in which this example will not help you recover.

NOTE

If you get into trouble, press RESET and ESC and start again. Be certain that CAPS LOCK key is locked in the down position.

Type:

ED TESTFILE.TXT (RETURN)

If this file does not already exist, ED returns with a prompt:

NEW FILE

.*

3.18.25 INSERT

Next, we must prepare to INSERT text into our file using the I command. Type:

I (RETURN)

ED is now ready to accept text into line 1:

1:

Begin typing the following text, ending each line with the RETURN key. (To maintain readability, it is suggested that each line be no more than 80 characters.) ED provides a new line number each time you press RETURN.

1: THE NPC-800C REPRESENTS A NEW TREND IN THE TEST AND MEASUREMENT INDUSTRY.

2: THE INTERNAL COMPUTING POWER OF THE MICROPROCESSOR IS NOW AVAILABLE TO THE USER.

3: TASKS SUCH AS AUTOMATIC TESTING, POSTPROCESSING, AND TEST FUNCTION EXPANSION ARE EASILY IMPLEMENTED.

To end the Text Insertion mode, simply press CTRL and Z simultaneously. Then press RETURN.

To end this session with ED,

Type:

E (RETURN)

The system now stores this text file on disk. When it returns with system prompt, A>, you may use DIR to see your new file in the directory. Notice that the system also creates a backup file, TESTFILE.BAK. You can use STAT to examine the file size if desired.

3.18.26 TYPE

TYPE is a built-in command used for quick and easy examination of source file contents. When executed, it displays the file exactly as it is stored on the disk.

Type:

TYPE TESTFILE.TXT (RETURN)

If you are examining a large file, you may want to stop the text before it scrolls off the CRT. Simultaneously press CTRL and S to stop scrolling; press any key to continue scrolling.

3.18.27 REN

REN renames an existing file. It does not duplicate the file under a new name, it merely changes the old name to the new one:

Type:

REN NEWNAME.DOC = TESTFILE.TXT (RETURN)

As an example of REN, execute the following commands:

REN CHECKIT.OUT = READ.ME

DIR allows you to verify that the file name has been changed.

3.18.28 ERA

ERA erases the specified file, FOREVER. Be certain that you specify the correct file. There is no way to recover erased files.

Type:

ERA NEWNAME.DOC (RETURN)
ERA TESTFILE.BAK (RETURN)

3.18.29 FORMAT 1 AND FORMAT 2

FORMAT 1 and FORMAT 2 are special transient commands supplied by Nicolet Paratronics. Since SYSGEN is not supplied with this system, FORMAT 1 and FORMAT 2 are used to format a new diskette (or reformat a used one) in preparation for use.*

Type:

FORMAT 2 (RETURN)

*Both FORMAT commands erase all programs listed in the directory on your diskette. Use FORMAT 2 for the NPC-800C integral disk drives. If you are using external drives, which are single-sided, then use FORMAT 1.

```
format2

FORMATTING PROGRAM FOR NPC 800 SERIES
VERSION 1.0 REV:A FOR DUAL SIDED DOUBLE DENSITY

WRITE ENABLED DISK READY TO FORMAT ON DRIVE B? (Y/N) n

COPY CP/M SYSTEM TO FORMATTED DISK? (Y/N) n
A>
```

Figure 3-92. FORMAT 2, Used To Format New NPC-800C Disk.

If desired, insert a "Write Enabled" blank diskette.

Type:

Y (RETURN)

The disk drive turns on and begins formatting the diskette.

3.18.30 ASM

ASM is the transient command which provides the ability to write an assembly language program for the 8080 or 8085. The following example illustrates the mechanics of writing a simple assembly language program using ED, assembling the program using ASM, converting the program to an executable file using LOAD, and finally, executing the program. For a detailed explanation of this procedure, refer to the CP/M Software Documentation Manual.

The first step in writing a program is to define the task to be performed. This example simply displays a message on the NPC-800C CRT. The next step is to create a file, using ED, with MSSGDISP as the main file name and .ASM as the file name extender. A sample file is shown in Figure 3-93.

```

;*****
;* this is a test program to illustrate the use of the assembler *
;*****
      org      0100h
rdbtest: lxi    b,dstart      ;ld start address
          lxi    h,0f100h    ;ld output address
start:
          ldax   b            ;ld data to accum.
          cpi    '$'         ;is data byte at end of string?
          jz     exit        ;yes,jmp to end and exit pgrm
          mov    m,a         ;move data byte to ram
          inc    h           ;inc data address
          inc    b           ;inc output address
          jmp    start       ;go back & ld next byte
exit:    ret                ;finish
dstart: db    'this is an example.....$'
          end

A>

```

Figure 3-93. Sample Source File Created By ED

3.18.31 .PRN FILE

After your program is written and stored on diskette, it must be assembled. Typing ASM MSSGDISP causes the transient program ASM to be loaded. ASM then loads MSSGDISP.ASM and creates two new files, MSSGDISP.PRN and MSSGDISP.HEX. The .PRN file is the one to be used when printing the source file (see Figure 3-94).

```

;*****
;* this is a test program to illustrate the use of the assembler *
;*****
0100          .org      0100h
0100 011301  rdbtest: lxi   b,dstart      ;ld start address
0103 2100F1          lxi   h,0f100h      ;ld output address

start:
0106 0A          ldax   b              ;ld data to accum.
0107 FE24          cpi   '$'          ;is data byte at end of string?
0109 CA1201       jz    exit          ;yes, jmp to end and exit pgrm
010C 77          mov    m,a          ;move data byte to ram
010D 23          inc   h              ;inc data address
010E 03          inc   b              ;inc output address
010F C30601       jmp   start          ;go back & ld next byte
0112 C9          exit:  ret          ;finish
0113 7468697320 start: db   'this is an example.....$'
012B          end

```

A>

Figure 3-94. Sample .PRN File Created By ASM

3.18.32 .HEX FILE

By using the transient program LOAD, the .HEX file (see Figure 3-95) creates the executable file. Typing LOAD MSSGDISP loads MSSGDISP.HEX and creates the file MSSGDISP.COM.

```

type rf.hex
:100100000113012100F10AFE24CA1201772303C35F
:100110000601C97468697320697320614E2065786F
:00012000616D706C652E2E2E2E2E248B
:0000000000

A>

```

Figure 3-95. Sample .HEX File Created by ASM

The file MSSGDISP.COM is now available to be executed.

Type:

MSSGDISP (RETURN)

3.18.33 EXECUTE

The NPC-800C now displays the message "THIS IS AN EXAMPLE OF THE ASSEMBLER" near top of CRT.

Using ED and steps illustrated above, you can change original file MSSGDISP.ASM, or create your own new program.

3.18.34 SUBMIT

The SUBMIT utility program allows the user to automatically, and sequentially, execute a series of CP/M command files.

To use this feature of CP/M, simply create a file, using ED (which contains a sequential list of the CP/M command files to be executed). Then type:

A SUBMIT FILENAME

2. ERA *.BAK Erases all backup files.
3. STAT *.COM \$\$ Displays statistics of all .COM files.
4. DIR Displays updated directory (without backup files).
5. ; (Blanks line for spacing).
6. ; THIS COMPLETES (Comment).

*If necessary, see CP/M Software Documentation Manual for editing procedures required to correct program entry errors.

3.18.36 Executing Analyzer Tests

One of the most powerful advantages of combining logic analysis with CP/M is the simplicity with which multiple tests, including user prompts, can be automated. In the following example, three separate analyzer tests and corresponding test instructions are created, stored, and executed using SUBMIT.

3.18.37 State Test

1. Press RESET to access analyzer operating system. Call 48 Channel State menu and enter 0040 as trigger word (leave all other menu parameters unchanged).
2. Connect A state probe to A side of Logic Analyzer Test Card supplied with NPC-800C (see Section 3.14 for a description of test card). State probe switches should be set to TTL and TRUE.
3. Press COLLECT to take and display a data collection. Save data in the auxiliary memory by pressing S.
4. Press CONFIG followed by ESC key to call CP/M operating system. When A prompt appears, type:

LASAVE STATE (RETURN)

to save the first test under the arbitrary file name: STATE. * When test is saved, CONFIGURATION LIST automatically appears.

3.18.38 Timing Test

1. Call 16 Channel Timing menu. Enter in a sample clock of 100 microseconds and trigger word of XXXXXXXX 00000000 (X = don't care). Also set PRETRIG to 00%.
2. Connect B timing probe to B side of test card. Then press COLLECT to take and display a data collection. Use X20 magnification. Save data in auxiliary memory by pressing S.
3. Call CONFIGURATION LIST and press ESC as before.

Type:

LASAVE TIMING (RETURN)

to save second test under arbitrary file name: TIMING.

3.18.39 Waveform Test (Optional Waveform Board Must Be Installed)*

1. Call Waveform Recorder menu. Set ATTENUATOR to 1V/DIV and Dynamic Range (–) 1.6 volts to (+) 6.4 volts.
2. Press S2 key to access Display mode. In this mode, press C key to call clock field in Timing menu. Set this clock to one microsecond. Step down to trigger LINKAGE field and select W for single-shot operation.
3. Connect Model 90 probe to WAVEFORM BNC at rear of NPC-800C (Make sure it is not connected to the CTSA BNC). With X10 selected, place probe tip at WF test point on test card and press COLLECT (Remember to connect probe ground wire). Select X1 magnification when waveform is displayed. Save data in auxiliary memory by pressing S key.
4. Call CONFIGURATION LIST and press ESC as before.

Type:

LASAVE WAVE (RETURN)

to save third test under arbitrary file name: WAVE.

If your NPC-800C does not have this option, continue with the procedure and ignore all references to waveform.

3.18.40 Directory

Press ESC and type DIR (RETURN) to verify that you have STATE, TIMING, and WAVE files on the diskette.

3.18.41 Operator Prompts

Using ED utility, you can create a message that prompts the user for each test. However, to keep the message on the screen until the user is ready to continue, a PAUSE program is required.

3.18.42 Automatic Testing

The SUBMIT program, which controls the logic analyzer, is called AUTOTEST. To incorporate prompting messages prior to each test, follow the procedure described below:

3.18.43 PAUSE

*If you've renamed LASAVE as S, type S STATE (RETURN) to save data.

The PAUSE program in Figure 3-97 is written in assembly language.

```

ed pause.asm

NEW FILE
: *i
1:      org      0100h
2:      mvi      c,1
3:      call     5
4:      ret
5:
: *e

A>asm pause.aax
CP/M ASSEMBLER - VER 2.0

0100      org      0100h
0100 0E01      mvi      c,1
0102 CD0500      call     5
0105 C9          ret
0106
000H USE FACTOR
END OF ASSEMBLY

A>p

```

Figure 3-97. PAUSE Program

When typing the program in Figure 3-97, press TAB key to achieve the spacing shown. Also, don't forget to type CTRL Z at line 5 to exit program entry. Command ASM PAUSE.AAX initiates program assembly.

After program assembly, type:

A>LOAD PAUSE

Check directory to verify your PAUSE program.

3.18.44 AUTOTEST

The program in Figure 3-98 combines analyzer tests, prompting messages, and the PAUSE program.*

*If necessary, consult the CP/M Software Documentation Manual for editing procedures required to correct program entry errors.

```

A)ed autotest.sub
: *i
1: ;
2: ; TO THE OPERATOR: YOU'RE GOING TO PERFORM 3 TESTS.
3: ; IT'S IMPORTANT THAT YOU FOLLOW THE INSTRUCTIONS CAREFULLY.
4: ;
5: ; STATE TEST: AFTER READING THE INSTRUCTIONS BELOW, PRESS RETURN
6: ; WHEN THE CURSOR FLASHES. THIS WILL CALL THE STATE TEST
7: ;
8: ; A. CONNECT THE A STATE PROBE TO THE A SIDE OF THE TEST CARD.
9: ; B. WHEN THE CONFIGURATION LIST APPEARS, PRESS THE COLLECT KEY.
10: ; C. AFTER THE TEST IS COMPLETE, PRESS THE CONFIG KEY FOLLOWED BY THE
11: ; ESC KEY TO RECEIVE INSTRUCTIONS FOR THE NEXT TEST.
12: ;
13: ; REMEMBER, PRESS RETURN WHEN THE CURSOR FLASHES.
14: PAUSE
15: LARECALL STATE
16: ;
17: ; TIMING TEST
18: ;
19: ; A. CONNECT THE B TIMING PROBE TO THE B SIDE OF THE TEST CARD.
20: ; B. WHEN THE CONFIGURATION LIST APPEARS, PRESS THE COLLECT KEY.
21: ; C. AFTER THE TEST IS COMPLETE, PRESS THE CONFIG KEY FOLLOWED BY THE
22: ; ESC KEY TO RECEIVE INSTRUCTIONS FOR THE NEXT TEST.
23: ;
24: PAUSE
25: LARECALL TIMING
26: ;
27: ; WAVEFORM TEST (OPTIONAL)
28: ;
29: ; A. CONNECT THE SCOPE PROBE TO THE WF TESTPOINT ON THE TEST CARD.
30: ; B. AFTER THE CONFIGURATION LIST APPEARS, PRESS THE COLLECT KEY.
31: ; C. THIS COMPLETES THE TEST SERIES.
32: PAUSE
33: LARECALL WAVE
34: ;
35: ; *E
36: ;

```

Figure 3-98. AUTOTEST Program

Don't forget CTRL Z on line 34. Also, if you previously renamed this command, replace LARECALL with R.

After entering this program, execute by typing:

SUBMIT AUTOTEST (RET)

and follow instructions. The NPC-800C executes each line exactly as it was originally typed in. You are encouraged to use this simple example as a model for more comprehensive automatic tests.

NOTE

If automatic tests, without operator intervention are required, the GPIB controller capability of the NPC-800C can be used (see Section 3.19).

3.19 IEEE-488 CONTROL

3.19.1 IEEE-488 Interface Controller

In recent years, the need for automated test and measurement equipment that uses the IEEE-488 bus has escalated. Such applications range from research projects, which require

extremely complex measurements, to production test, which requires the same test be performed repetitively, without deviation, from the prescribed process.

The IEEE-488 General Purpose Interface Bus (or GPIB) allows the user to configure a test system to include most types of test instruments. Because of its interface standardization, the GPIB controller permits instruments from different manufacturers to be readily connected.

A basic NPC-800C can be used in the "device" as a "listener" and/or "talker." With the computer/controller option installed, using CP/M and CBASIC, it can also function as a bus controller.

The command set has been designed to be accessed from any application program. It has not been restricted to a specific language (such as CBASIC). Therefore, GPIB control functions can be available from many CP/M-compatible higher-level languages. However, CBASIC is easy to use and quite satisfactory for most applications.

All descriptions of controller commands assume that the computer/controller option is installed, and that CBASIC is the program language.

Most interface characteristics are user-definable using the keyboard or an application program. However, using a switch on the processor board, some may be set to an initial default value.

3.19.2 IEEE-488 Parallel Interface Port

The Processor Board DIP Switch Settings options are shown below:

GPIB DEVICE ADDR	TERMINATION SEQUENCE:	
ON = 0 OFF = 1	ALWAYS ON EOI	
(ADDR31 DEFAULTS to 30)	<u>SW6</u>	<u>SW7</u>
A0 = SWITCH 1	ON	ON
A0 = SWITCH 2	ON	OFF
A2 = SWITCH	OFF	ON
A3 = SWITCH 4	OFF	OFF
A4 = SWITCH 5		
		EOI ONLY
		CR
		LF
		CR,LF
 SWITCH 8		
ON = 60 Hz		
OFF = 50 Hz		

3.19.3 Command Set Summary

The following command set summary provides an overview of available functions. The remainder of this section describes each command in detail.

3.19.4 ABORT GPIB

This command, which clears the interface, stops all transactions presently taking place on the bus and initializes the interface.

3.19.5 RESET

Performs reset function on each instrument—individually or universally.

3.19.6 REMOTE

Enables one or all instruments to respond to controller's commands.

3.19.7 LOCAL

This command, which is the opposite of REMOTE, returns one or all instruments to local, front-panel control.

3.19.8 TRIGGER

Used after an instrument has been set up to make a data collection. Typically, several instruments are set up in sequence. Then all are TRIGGERED simultaneously to make a data collection.

3.19.9 REQUEST

Asserts the Request For Service line, SRQ. Normally REQUEST is used when the NPC-800C is acting as a LISTENER/TALKER on the bus.

3.19.10 OUTPUT

Sends data to each instrument usually in the form of a string of characters interpreted by the instrument as set-up instructions.

3.19.11 ENTER

Opposite of OUTPUT, it instructs instrument to send data to the controller (data are usually the result of a specific test).

3.19.12 STATUS

Serially requests status of each instrument to determine whether it has completed the last instruction.

3.19.13 SET TIMEOUT

Changes maximum time to wait for a response on the bus.

3.19.14 LOCAL LOCKOUT

Used by controller to lock all devices under remote control and disable front-panel input. (LOCAL ALL command is used to defeat LOCAL LOCKOUT).

3.19.15 CONFIGURE

Used by NPC-800C to set up data transmission between devices other than the NPC-800C.

3.19.16 EOI STATUS

Used after a CONFIGURE command, it identifies end of data transmission between devices.

3.19.17 SENDBUS

A special command used to tailor controller output for custom applications.

3.19.18 TERM SEQ

Allows user flexibility in specifying data termination sequences (when used with subsequent OUTPUT or ENTER commands).

The above command set is used to perform most common functions required in a GPIB test system. The IEEE-488 standard interface connector, located on back panel of NPC-800C, allows easy interface to instruments being controlled.

3.19.19 Reference Documents

Refer to the following documents for an elaboration of material presented in following sections:

- CBASIC Language Manual
- TMS9914 GPIB Adaptor Data Manual
- ANSI/IEEE Std. 488-1978

3.19.20 Abbreviations

ATN	Attention
DAB	Data Byte
DCL	Device Clear
GET	Group Execute Trigger
GTL	Go to Local
IFC	Interface Clear
LA	Listen Address
LAG	Listen Address Group*
MA	My Address
MLA	My Listen Address
MTA	My Talk Address
SCG	Secondary Command Group
SDC	Selected Device Clear
SPD	Serial Poll Disable
SPE	Serial Poll Enable
SRQ	Service Request
STB	Status Byte
TA	Talk Address
TAG	Talk Address Group**
TLC	Talker/Listener/Controller
UNL	Unlisten
UNT	Untalk

* LAG is defined as LA SCG LA SCG

**TAG is defined as TA SCG, where XXX indicates to duplicate "XXX" 0 or more times

3.19.21 General Discussion

The GPIB command package allows the NPC-800C to be used as a GPIB system controller, with a CP/M operating system, and a TMS9914 GPIB adaptor chip. The GPIB command package uses the TMS9914 to control and interface to the bus. Commands can be used directly from an 8085 assembler program, or from a higher level language, such as CBASIC (software interface to commands is very flexible, allowing easy implementation from a variety of other languages).

When using the NPC-800C as a controller, the application program should treat the internal logic analyzer as a “device on the bus,” just as if it were an external instrument.

As a system controller, the NPC-800C can transfer data to and from devices, respond to a service request, and send these GPIB commands: Remote/Local Changes, Device Clear, Selected Device Clear, Group Execute Trigger and Serial Poll. Commands and data output can be sent to any combination of bus listeners. A complete secondary addressing capability is also available. As a bus device, the NPC-800C can request service, respond to a serial poll and transfer data across the bus when addressed by the controller. A bus status command can be executed at any time to get the complete NPC-800C interface and GPIB status.

3.19.22 Detailed GPIB Command Descriptions

This section provides a description of each of the GPIB commands including command references.

3.19.23 I/O Configuration Menu

The I/O Menu is used to enable interface, set the bus address—and optionally—to define the data termination sequence.

3.19.24 To Call Menu

1. press CONFIG or RESET key, then
2. press I key.

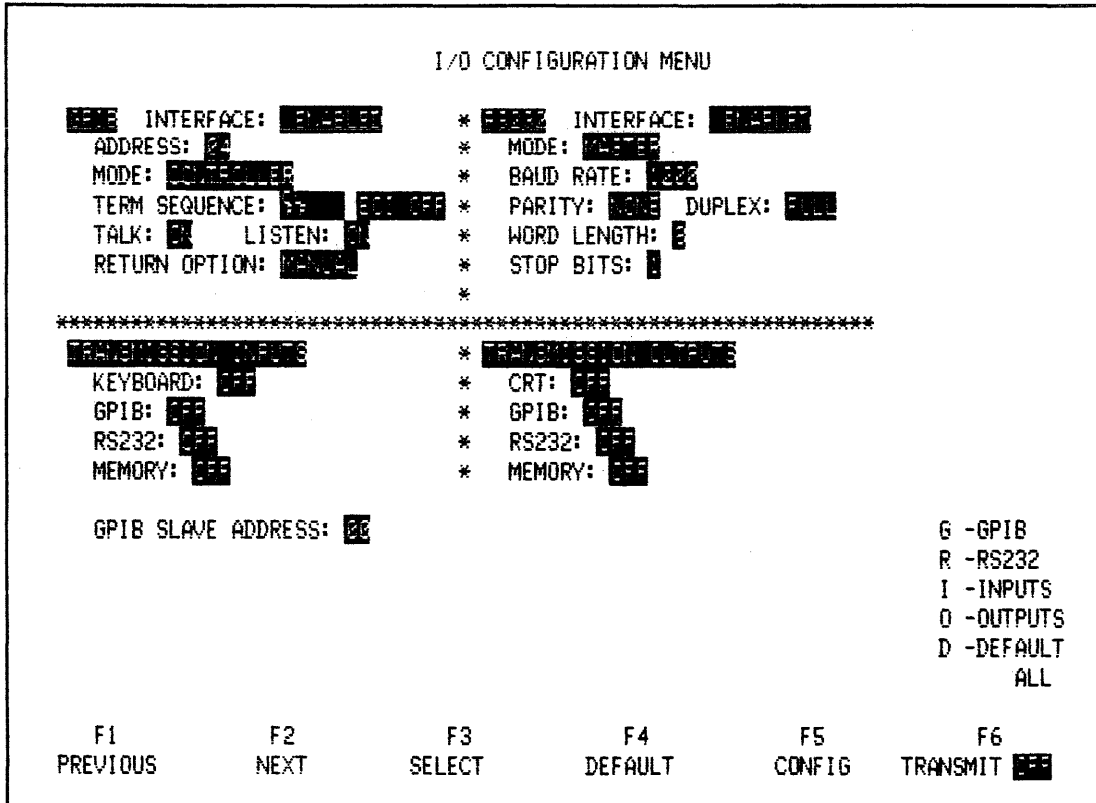

Figure 3-99. I/O Menu

3.19.25 Explanation Of Menu (GPIB Section)

3.19.26 Interface

Line 1: INTERFACE field defaults to ENABLED. This allows the NPC-800C to be either a CONTROLLER or DEVICE on the GPIB bus. Pressing SELECT key puts interface into a DISABLED state in which the NPC-800C is effectively disconnected from the bus.

3.19.27 Address

Line 2: ADDRESS field defines address of NPC-800C on GPIB bus. Pressing SELECT key increments address of device. Valid addresses are 00 through 30. Default address is 04.

3.19.28 Mode

Line 3: The MODE field determines if the NPC-800C is a DEVICE or CONTROLLER on the GPIB bus. Default condition is set by section 2 on DIP switch located on processor board. The unit is a CONTROLLER if switch is in OFF position (switch is read during power up and when RESET key is pressed). Pressing SELECT key changes MODE to DEVICE.

Table 3-1. Power Up/Reset I/O Initialization

SWITCH 2	
ON	OFF
DEVICE	CONTROLLER

3.19.29 Termination Sequence

Line 4: TERMINATION SEQUENCE field defines end of data transmission. Flashing cursor is initially placed in ASCII character field. Pressing SELECT key changes sequence to CRLF (carriage return - line feed); CR alone; LF alone; or NULL (no ASCII characters). If NULL is selected, EOI ON automatically is selected and cannot be changed. If NULL is not selected, pressing NEXT key moves flashing cursor to EOI selection portion of TERMINATION SEQUENCE. Pressing SELECT key changes EOI to ON or OFF. If EOI ON is selected, EOI is sent out with last character of termination sequence previously selected or with last character of data if NULL was selected. Default states for the TERMINATION SEQUENCE field are CRLF and EOI OFF.

3.19.30 Talk Listen

Line 5: These fields, which determine whether NPC-800C is a TALKER, LISTENER, or both on GPIB bus, normally default to ON. With ON cursor flashing, press SELECT key to disable function and set field to OFF.

3.19.31 Return Option

Line 6: RETURN OPTION field defines the way the NPC-800C returns to the CP/M Calling Program from the ANALYZER mode. The field defaults to AUTO. Pressing SELECT key changes field from AUTO to AUTO/MAN, to MANUAL. In AUTO mode, the return to CP/M takes place immediately after command string has been executed by the analyzer. In MANUAL mode, return to CP/M takes place when R key is pressed (R key is not defined in this menu). In AUTO/MAN mode, a return to CP/M takes place immediately after command string has been executed by the analyzer; except when a data collection is being initiated by the command string. After data collection is completed, the return to CP/M is the same as described above for MANUAL mode.

3.19.32 Transmission Inputs

This section defines the source(s) of data that are sent to the interface or memory defined in the TRANSMISSION OUTPUTS section which follows.

3.19.33 Keyboard

Line 7: The KEYBOARD field normally defaults to OFF. The keyboard can only be used to configure and control the analyzer in the OFF state. With OFF cursor flashing, to transmit data to the interface(s) selected in the TRANSMISSION OUTPUTS section, press SELECT key (turns KEYBOARD field ON).

3.19.34 GPIB

Line 8: The GPIB field normally defaults to OFF. If INTERFACE field in GPIB section of menu is DISABLED, GPIB field is forced to OFF and cannot be changed. With OFF cursor flashing, pressing SELECT key turns this field ON and enables the NPC-800C to receive data from another device over the GPIB bus and to send data to the destination(s) selected in the TRANSMISSION OUTPUTS section (which follows).

3.19.35 RS-232 and Memory

Line 9: RS-232 field normally defaults to OFF. If INTERFACE field in RS-232 section of menu is DISABLED, RS-232 field is forced to OFF and cannot be changed. With OFF cursor flashing, pressing SELECT key turns this field ON and enables the NPC-800C to receive data from another device over the RS-232 interface and to send data to the destination(s) selected in the TRANSMISSION OUTPUTS section (which follows).

Line 10: MEMORY field normally defaults to OFF. If MODE field in GPIB section is set to DEVICE and mode field in RS-232 section is set to SLAVE, the field is forced to OFF and cannot be changed. With OFF cursor flashing, pressing SELECT key provides several combinations of memory data to be transmitted over the GPIB or RS-232 interfaces. With field flashing, pressing SELECT key allows you to select TIMING or STATE memory to be transmitted. Pressing NEXT key moves flashing cursor to SETUP field. With SETUP field flashing, pressing SELECT key allows you to select the memory type to be transmitted. The choices are SETUP, DATA, or AUX. Pressing DEFAULT key when either field is flashing sets both fields to OFF.

3.19.36 Transmission Outputs Section

3.19.37 CRT

Line 7: CRT field, which normally defaults to OFF, displays configuration menus and data collection displays in the OFF state. With OFF cursor flashing, pressing SELECT key turns CRT ON to display data received on the interface(s) selected in the TRANSMISSION INPUTS section.

3.19.38 GPIB

Line 8: GPIB field normally defaults to OFF. If INTERFACE field in GPIB section of menu is DISABLED, GPIB field is forced to OFF and cannot be changed. With OFF cursor flashing, pressing SELECT key turns this field ON and enables the NPC-800C to transmit data to another device over the GPIB bus. The data sent are from the source(s) selected in the TRANSMISSION INPUTS section.

3.19.39 RS-232

Line 9: RS-232 field normally defaults to OFF. If INTERFACE field in RS-232 section of menu is DISABLED, RS-232 field is forced to OFF and cannot be changed. With OFF cursor flashing, pressing SELECT key turns this field ON and enables NPC-800C to transmit data to another device over the RS-232 interface. The data sent are from the source(s) selected in the TRANSMISSION INPUTS section.

3.19.40 Memory

Line 10: MEMORY field normally defaults to OFF. If MODE field in GPIB section is set to DEVICE and MODE field in RS-232 section is set to SLAVE, the field is forced to OFF and cannot be changed. With OFF cursor flashing, pressing the SELECT key provides several combinations of memory to receive data from another NPC-800C over the interface selected in the TRANSMISSION INPUTS section. With the field flashing, pressing SELECT key allows you to select TIMING OR STATE memory to receive data. Pressing NEXT key moves flashing cursor to SETUP field. With SETUP field flashing, pressing SELECT key allows you to select the memory type to receive data. Choices are SETUP, DATA, or AUX. Pressing DEFAULT key, when either field is flashing, sets both fields to OFF.

3.19.41 GPIB Slave Address

Line 12: GPIB SLAVE ADDRESS field is displayed only if MODE field in GPIB section is set to CONTROLLER. Pressing SELECT key increments the address. Valid addresses are 00 through 30. The field defines the GPIB address of another NPC-800C (or another device*) to which the data or memory block are sent, as defined in the TRANSMISSION INPUTS or OUTPUTS section.

3.19.42 Labels

Lines 11 to 15: These fields are labels to define direct entry key functions. Pressing G, R, I, or O moves flashing cursor to associated section of menu. Pressing D sets every field to its default state.

If MEMORY input or MEMORY output is selected, the TRANSMIT key initiates data transmission. The field will show TRANSMIT ON during transmission and changes back to TRANSMIT OFF upon transmission completion.

NOTE

Only one MEMORY (input or output) is allowed to be selected. The other MEMORY is forced to OFF.

*The format of some of transferred data is unique and only a NPC-800C can use it without translation. This field is not normally used.

3.19.43 Abort GPIB or INIT GPIB

This command will ABORT any pending bus transactions, put all devices in remote, and assert the NPC-800C as the active controller. Also, all necessary initialization for proper bus functioning is performed. If TALKER/LISTENER/CONTROLLER (TLC) mask specifies that the NPC-800C is not the system controller, only initialization in the NPC-800C will be performed; bus configuration remains unchanged.

Sequence

1. Reset TMS9914 bus controller chip
2. Save MAX-TIMEOUT in parameter area
- *3. Set IFC
- *4. Wait 100 microseconds
- *5. Set IFC
- *6. Set REN

*These steps are performed only if TLC mask = XX1

3.19.44 Reset

The RESET command places a device (or devices) into a known initial state. Two different RESETS are implemented. If an address list is specified, an SDC command is sent to each device in the list. Otherwise, a DCL command is sent to all devices. Whether a device implements a DCL or SDC, and also implements the actual effects of the command, depends on the particular instrument used. Only the active controller can issue a RESET.

Sequence For No Address List

1. Set ATN
2. Send DCL

Sequence For Address Specified

1. Set ATN
2. Send MTA
3. Send UNL
4. Send LAG
5. Send SDC

3.19.45 Remote

Sent by the active controller, the REMOTE command places one or more devices under GPIB control. It can be issued to all devices or to any specified device or group of devices. Normally, the REMOTE to all devices is not necessary, because it is also executed during the ABORT GPIB command. A device (or devices) can be removed from REMOTE state with a LOCAL command, then later toggled back to REMOTE.

Sequence For REMOTE-All Devices

1. Set REN

Sequence For REMOTE Device

1. Set REN
2. Set ATN
3. Send MTA
4. Send UNL
5. Send LAG

NOTE

Actual state of a device on the bus when in REMOTE is device dependent.

3.19.46 Local

LOCAL command is used to remove a device from GPIB control and return it to its "normal" front-panel operation. This command may be issued to all devices or to any subset of devices. LOCAL command has no effect if a LOCAL LOCKOUT has been issued by a controller and not cleared.

Normally LOCAL command is sent by the active controller. However, two special cases are

permitted when the NPC-800C is not the active controller. If no address is specified, the NPC-800C is set to the LOCAL state, independent of the active controller. If the NPC-800C is not the active controller and its own address is specified, it will "LOCK" itself in the LOCAL state, so that the active controller has no access. Sending a LOCAL command again with no address will "UNLOCK" the NPC-800C.

Sequence For All Devices

1. Set REN

Sequence For A Device

1. Set ATN
2. Send MTA
3. Send UNL
4. Send LAG
5. Send GTL

3.19.47 Trigger

TRIGGER command is sent by the active controller to initiate a device function (for example, take DMM reading and send burst of pulses from pulse generator). TRIGGER command is sent only to those addresses specified and to all devices simultaneously; however, internal device delays should be considered for proper operation.

Sequence for TRIGGER Device(s)

1. Set ATN
2. Send MTA
3. Send UNL
4. Send LAG
5. Send GET

3.19.48 Request

REQUEST command is used to set the status byte that the active controller reads from MA during a serial poll. If BIT 6 of the status byte is set, a service request is sent to the controller. REQUEST has no function when in active controller state, but status is set when this state is exited.

Sequence

1. Set STB
- *2. Set SRQ
- *3. After active controller executes a serial poll, set SRQ.

*Only when BIT 6 = 1

3.19.49 Output

When in active controller state, OUTPUT command transfers DATA to all devices specified in the address list. When in TALKER-only state, data are transferred to any devices that have been set to listen by the active controller. In this example, the NPC-800C is not the initiating

device, and only outputs data after it is requested. Data string length is 0 to 65,535 characters (0 to 255 from CBASIC).

Sequence

1. Set ATN
2. Send MTA
3. Send UNL
4. Send LAG
5. Set ATN
6. Send DAB
7. Repeat 6 for additional characters
8. Send TERMINATION SEQUENCE

Sequence For TALKER-Only

1. Send DAB
2. Repeat 1 for additional characters
3. Send TERMINATION SEQUENCE

3.19.50 Enter

When in active controller state, ENTER command transfers data from device specified to the NPC-800C. When in LISTENER-only state, data are transferred from TALKER to NPC-800C. Data string length is 0 to 65,535 characters (0 to 255 from CBASIC).

Sequence

- *1. Set ATN
- *2. Send UNL
- *3. Send MLA
- *4. Send TAG
- *5. Set ATN
6. Enter DAB
7. Repeat Step 6 until TERMINATION SEQUENCE is satisfied.
- *8. Set ATN
- *9. Send UNT

*Used only in active controller mode.

If in LISTENER-only state, it is user's responsibility, using STATUS command, to first determine that data are being transferred to the NPC-800C.

3.19.51 Status

There are three different STATUS command functions. The first can be executed at any time using address = "B" (controller or noncontroller). This command returns MA for NPC-800C and TALKER/LISTENER/CONTROLLER status (active, idle, or not allowed for each function). Also, the occurrence of any of the following bus commands is reported:

GET
 DCL
 SDC
 MA
 UNIDENTIFIED COMMAND
 HANDSHAKE ERROR
 IFC
 SRQ

STATUS command's second form is implemented by specifying the address of one GPIB device. This returns device STATUS BYTE, which occurs after a SERIAL POLL.

The third form of the STATUS command is implemented by not specifying an address. This causes a serial poll of all bus addresses. The return data are the status of each bus address (active, inactive, or service required).

Sequence For Address

1. Set ATN
2. Send UNL
3. Send MLA
4. Send TA
5. Send SPE
6. Set ATN
7. Receive STB
8. Set ATN
9. Send SPD
10. Send UNT

Sequence For "No" Addresses

1. Set ATN
2. Send UNL
3. Send MLA
4. Send SPE
5. Send TA(1)
6. Set ATN
7. Receive DAB
8. Set ATN
9. Repeat 5 thru 8 for TA(2) thru TA(30)
10. Send SPD
11. Send UNT

3.19.52 Set Timeout

SET TIMEOUT command can be issued at any time to change the maximum time (in milliseconds) to wait for a response on the bus. The ABORT GPIB command resets max time to a default time specified in the primitives.

3.19.53 Local Lockout

LOCAL LOCKOUT (LLO) is a GPIB universal command. It can be issued by the active controller to lock all devices under GPIB remote control and disable front-panel local control (if any). A LOCAL ALL command must be used to defeat the LOCAL LOCKOUT.

Sequence

1. Set ATN
2. Send LLO

3.19.54 Configure

CONFIGURE command can be used when NPC-800C is active controller to set up GPIB for data transmission between devices (other than NPC-800C). One TALKER and any number of LISTENERS can be specified. After bus is configured, ATN is set false to allow TALKER to begin transmitting data. EOI STATUS command can be used to look for an occurrence of EOI (signifies that data transmission has been completed).

Sequence

1. Set ATN
2. Send UNL
3. Send LAG
4. Send TAG
5. Set ATN

3.19.55 EOI Status

EOI STATUS command is a special-purpose command (designed to be used after a CONFIGURE) (indicates end of data transmission between devices).

3.19.56 SENDBUS

SENBUS command allows the user to tailor controller output for a special application. Any sequence of universal commands, addressable commands, or data can be specified—up to a maximum of 65,535 bytes (255 bytes for CBASIC).

3.19.57 TERM SEQ

TERM SEQ command allows flexible data termination sequences to be used in any subsequent OUTPUT or ENTER command. Several options are available:

1. Terminate output and enter with CR-LF.
2. Output—Same as 1, but with EOI true for LF.
Enter—Terminate on EOI.
3. Output—Force EOI on last data byte.
Enter—Terminate on EOI.
4. Same as 1, but any termination sequence (up to 5 bytes) can be specified in place of CR-LF.
5. Same as 4, but EOI is forced on last byte of specified termination sequence.

3.19.58 GPIB Command Implementation Via CBASIC

Following is a description of how to use each GPIB command from a CBASIC PROGRAM. To use GPIB from CBASIC, the file GPIB.BAS must be inserted (ahead of any GPIB command references) in a CBASIC PROGRAM (before compilation). This is done using the EDITOR or by using: % INCLUDE GPIB.

This CBASIC directive includes GPIB.BAS in the compilation that directly follows its placement. This file contains CBASIC source code which defines GPIB FUNCTION definitions. If necessary, to conserve memory space, any of these function definitions, which are not needed by a user program, can be deleted.

In the GPIB, function definition headings are several variables that the user may wish to change:

1. start address of GPIB commands in PROM, or
2. start address of 32 byte RAM parameter & stack area.

For each GPIB command, a CBASIC statement format is defined. This is the recommended format; it can be modified for a particular application. Any valid CBASIC statement can be used if the function call is intact.

3.19.59 ABORT GPIB Or INIT GPIB

Statement Format (type on one line):

STMT NUMBER GPIB.RET% = FN.ABORT.GPIB%
or GPIB.RET% = FN.INIT.GPIB%

Parameters: None

Options: None. (However, the effects of the command depends on whether NPC-800C is system controller).

Purpose:

1. Initialization
2. Abort pending bus transactions
(only when system controller)
3. Take control of bus
(only when system controller)

Return Code: GPIB.RET% = 0 NPC-800C is active/system controller
GPIB.RET% = 1 NPC-800C is device

NOTE

To assure proper initialization, INIT GPIB command must be used prior to any other GPIB command in a program

3.19.60 RESET

Statement Format (type on one line):

STMT NUMBER GPIB.RET% = FN.RESET%(ADDRESS LIST)

Parameters:

ADDRESS LIST is an ASCII string which specifies which bus devices are to be RESET (see Section 3.19.74 for Data Format).

Options:

1. ADDRESS LIST = "valid Section 3.19.74 format" data. This sends a Selected Device CLEAR (SDC) to all bus devices specified.
2. ADDRESS LIST = NULL. This sends a DCL to all bus devices.

Purpose:

1. Send a SDC to each address specified in ADDRESS LIST, or
2. Send a DCL to all devices on GPIB.

Return Code:

GPIB.RET% equals 0 if command is executed properly; otherwise one or more error bits are set as follows:

ERROR DEFINITION

- Bit 0 — NPC-800C is not active controller
- Bit 1 — Not used
- Bit 2 — Timeout
- Bit 3 — Invalid ADDRESS LIST format

NOTE

RESET command does not reset GPIB. Actual effect of command (if any) depends on its implementation in bus devices.

3.19.61 REMOTE

Statement Format (type on one line):

```
STMT NUMBER   GPIB.RET% = FN.REMOTE%
                ( ADDRESS LIST )
```

Parameters:

ADDRESS LIST is an ASCII string which specifies which bus devices are to be set to GPIB control (see Section 3.19.74 for data format).

Options:

1. ADDRESS LIST = "valid Section 3.19.74 format" data. Used when NPC-800C is active controller. Sets specific bus devices back to GPIB bus control after a LOCAL command with Option 1 has been executed.
2. ADDRESS LIST = NULL. Used when NPC-800C is active controller. Re-asserts REN LINE, after a LOCAL (with Option 2) has been executed.

Purpose:

To set bus or bus devices back to GPIB control after a LOCAL command has been executed.

Return Code:

GPIB.RET% equals 0 if command is executed properly, otherwise, one or more error bits are set, defined as follows:

ERROR DEFINITION

- Bit 0 — NPC-800C is not active controller
- Bit 1 — Not used
- Bit 2 — Timeout
- Bit 3 — Invalid ADDRESS LIST format

NOTE

A REMOTE command with Option 2 does not place devices in REMOTE if they have been set to LOCAL using Option 1. They must be set back to remote using Option 1 format.

3.19.62 LOCAL

Statement Format (type on one line):

STMT NUMBER GPIB.RET% = FN.LOCAL%
(ADDRESS LIST)

Parameters:

ADDRESS LIST is an ASCII string that specifies which bus devices are to be set to LOCAL (front panel) operation (see Section 3.19.74 for data format).

Options:

1. ADDRESS LIST = "valid Section 3.19.74 format" data. Used when NPC-800C is active controller, command specifies devices to LOCAL.
2. ADDRESS LIST = NULL. When NPC-800C is active controller, a DCL is sent to all devices. If NPC-800C is not active controller, it is set to LOCAL.
3. ADDRESS LIST = "L". Used when NPC-800C is not active controller. This option locks NPC-800C in local until a LOCAL command using Option 2 is executed.

Purpose:

Remove a device (or devices) from GPIB bus control and return it to "front panel" operation.

Return Code:

GPIB.RET% equals 0 if command is executed properly, otherwise one or more error bits are set, defined as follows:

ERROR DEFINITION

- Bit 0 — Improper controller state
- Bit 1 — Not used
- Bit 2 — Timeout
- Bit 3 — Invalid ADDRESS LIST format

3.19.63 TRIGGER

Statement Format (type on one line):

STMT NUMBER GPIB.RET% = FN.TRIGGER%
(ADDRESS LIST)

Parameters:

ADDRESS LIST is an ASCII string specifying which bus devices are to receive Group Execute Trigger (GET) command (see Section 3.19.74 for data format).

Options: None

Purpose:

To send a GET command (simultaneously) to all devices specified in address list.

Return Code:

GPIB.RET% equals 0 if command is executed properly; otherwise one or more error bits are set as follows:

ERROR DEFINITION

- Bit 0 — NPC-800C is not active controller
- Bit 1 — Not used
- Bit 2 — Timeout
- Bit 3 — Invalid ADDRESS LIST format

NOTE

When using TRIGGER command to trigger multiple devices simultaneously, it is important to consider response times of instruments as they can vary widely (from millisecond to second).

3.19.64 REQUEST

Statement Format (type on one line):

STMT NUMBER GPIB.RET% = FN.REQUEST%
(STATUS)

Parameters:

STATUS is an INTEGER that is sent (LSB only) on the GPIB as a response to a serial poll by the active controller.

Options:

Bit 6 of STATUS is used to request service from the active controller. If it is set, an SRQ is generated. The remaining seven bits can be defined by the user.

Purpose:

1. Load GPIB status byte
2. Optionally generate an SRQ

Return Code: Bit 2 Timeout

NOTE

1. *ABORT.GPIB* clears status byte.
2. *RESET to MA* clears status byte.
3. *REQUEST* can be executed when NPC-800C is active controller and status byte is loaded, but no other action will take place.

3.19.65 OUTPUT

Statement Format (type on one line):

STMT NUMBER GPIB.RET% = FN.OUTPUT%
(ADDRESS LIST, DATA)

Parameters:

DATA, an ASCII string, is sent to all bus devices that are set to listen. It can be any valid CBASIC string expression (0 to 255 characters).

ADDRESS LIST, an ASCII string, specifies bus devices which are to listen to data (see Section 3.19.74 for data format).

Options:

1. ADDRESS LIST = "valid Section 3.19.74 format" data. Used when NPC-800C is active controller and specifies bus LISTENERS.
2. ADDRESS LIST = NULL. Used when NPC-800C is not active controller.

Purpose:

Transmit ASCII data from NPC-800C to other bus devices

Return Code:

GPIB.RET% equals 0 if command is executed properly, otherwise one or more error bits are set, defined as follows:

ERROR DEFINITION

- Bit 0 — Improper controller state
- Bit 1 — In device mode and not addressed to talk
- Bit 2 — Timeout
- Bit 3 — Invalid ADDRESS LIST format
- Bit 4 — NPC-800C is not a TALKER

NOTE

To signify end of transmission, TERMINATION SEQUENCE is transmitted immediately following data.

3.19.66 ENTER

Statement Format (type on one line):

STMT NUMBER DATA\$ = FN.ENTERS\$(ADDRESS)

Parameters:

DATA, a string variable, contains ASCII data entered from a device (after execution).

ADDRESS, an ASCII string, specifies address of device which is to talk on bus (see Section 3.19.74 for data format).

Options:

1. ADDRESS LIST = "valid Section 3.19.74 format" data. Used when NPC-800C is active controller.
2. ADDRESS LIST = NULL. Used when NPC-800C is not active controller or for continuing the entering of long data strings.

Purpose: To transmit data from another device on GPIB to NPC-800C.

Return Code:

GPIB.RET% equals 0 if command is executed properly; otherwise one or more error bits are set as follows:

ERROR DEFINITION

- Bit 0 — Improper controller state
- Bit 1 — In device mode and not addressed to listen
- Bit 2 — Timeout
- Bit 3 — Invalid (address) format
- Bit 4 — NPC-800C is not a LISTENER
- Bit 5 — Input data has been truncated

NOTE

1. *Data are entered from TALKING device until termination sequence is encountered. However, only first 255 bytes are saved in data.*
2. *To continue entering data when truncated, use ADDRESS = NULL mode repetitively until data transfer is complete (GPIB.RET%=0).*

3.19.67 STATUS

Statement Format (type on one line):

STMT NUMBER DATA\$ = FN.STATUS\$(ADDRESS)

Parameters:

DATA, a string variable, contains the status of the device (or devices) specified by ADDRESS.

ADDRESS, an ASCII string, specifies address of device whose status is required (see Section 3.19.74 for data format).

Options:

ADDRESS = "valid Section 3.19.74 format" data return STB for device specified by address.

ADDRESS = NULL returns status of all bus addresses (present, not present, or service required).

ADDRESS = "B" returns bus status (hardware status, NPC-800C bus address (MA), and TLC mask).

Purpose:

1. perform serial poll of specific device and return its status byte, or
2. get configuration status (what devices are present, who is requesting service), or
3. get all available NPC-800C GPIB status.

Return Code:

GPIB.RET% equals 0 if command is executed properly; otherwise, one or more error bits are set as follows:

ERROR DEFINITION

Bit 0 — Not active controller
 Bit 1 — Not used
 Bit 2 — Timeout
 Bit 3 — Invalid address format
 Bit 15-8 — Device status byte

DEFINITION FOR BUS STATUS

Bit 0 — REN is true
 Bit 1 — IFC is true
 Bit 2 — SRQ is true
 Bit 3 — EOI is true

Bit 4	—	NRFD is true
Bit 5	—	NDAC is true
Bit 6	—	DAV is true
Bit 7	—	ATN is true
Bit 8	—	IFC has occurred
Bit 9	—	SRQ has occurred
Bit 10	—	MA has occurred
Bit 11	—	DCL has occurred
Bit 12	—	Not used
Bit 13	—	Unidentified
Bit 14	—	Incomplete handshake has occurred
Bit 15	—	GET has occurred

3.19.68 SET TIMEOUT

Statement Format:

STMT NUMBER GPIB.RET% = FN.SET.TIMEOUT%(TIME)

Parameters:

TIME is the desired maximum time (binary) to wait for all devices to respond to bus transactions (in milliseconds).

Options: None

Purpose:

Used to initially specify the maximum time in a program, or to temporarily change the time to allow for an extremely slow device response.

Return Code: Not used

NOTE

ABORT.GPIB (or INIT.GPIB) command resets maximum timeout to a default value; specified in primitives of five seconds.

3.19.69 LOCAL LOCKOUT

Statement Format:

STMT NUMBER GPIB.RET% = FN.LOCAL.LOCKOUT%

Parameters: None

Options: None

Purpose: To enable local lockout feature of GPIB (a universal command).

Return Code:

GPIB.RET% equals 0 if command is executed properly; otherwise one or more error bits are set as follows:

ERROR DEFINITION

- Bit 0 — NPC-800C is not active controller
- Bit 1 — Not used
- Bit 2 — Timeout

NOTE

Setting REN false (that is, LOCAL with null address list) disables LOCAL LOCKOUT state.

3.19.70 CONFIGURE

Statement Format (Type on one line):

STMT NUMBER GPIB.RET% = FN.CONFIGURE(TALK ADDRESS, LISTEN ADDRESS LIST)

Parameters:

TALK ADDRESS, an ASCII string, specifies data output device (see format for "ADDRESS" in Section 3.19.74).

LISTEN ADDRESS LIST, an ASCII string, specifies which bus devices are to receive data from talking device (see format for ADDRESS LIST in Section 3.19.74).

Options: None

Purpose:

To configure GPIB to transfer data between devices on the bus without having the controller handle data, thus optimizing transfer rate and freeing controller for other duties.

Return Code:

GPIB.RET% equals 0 if command is executed properly; otherwise one or more error bits are set as follows:

	ERROR DEFINITION
Bit 0 —	Not active controller
Bit 1 —	Not used
Bit 2 —	Timeout
Bit 3 —	Invalid ADDRESS format

NOTE

After configuring GPIB TALKER and LISTENERS, ATN is set false, which initiates data transfer. EOI STATUS command should then be used to detect end of this data transfer (if necessary).

3.19.71 EOI STATUS

Statement Format (Type on one line):

STMT NUMBER GPIB.RET% = FN.EOI.STATUS%

Parameters: None

Options: None

Purpose: To detect end of data transmission between devices setup by a CONFIGURE statement.

Return Code:

GPIB.RET% equals 0 if EOI has not occurred, and 8 if it has occurred.

NOTE

This command should only be used after a CONFIGURE has been executed. If executed at other times, GPIB interface could possibly be left in an unknown state.

3.19.72 SENDBUS

Statement Format (Type on one line):

STMT NUMBER GPIB.RET% + FN.SEND.BUS% (COMMAND/DATA STRING)

Parameters:

COMMAND/DATA STRING contains the combined command and data to be output by the controller. Two characters are used to control output type (command or data). A colon signifies the switch to COMMAND output (ATN true) and a semicolon signifies the switch to DATA output (ATN false). For example; the string “:?(;WAKEUP:6*;START” would have this effect:

```

:      : set ATN
?      ? send UNL
(      ( send LISTEN ADDRESS 8
:      ; set ATN false
WAKE UP : data sent to address 8
:      : set ATN
6*     6* send listen address 22 and 10
:      ; set ATN false
START  : data sent to address 8, 10 & 22
    
```

Refer to
ASCII & GPIB Code
Chart in Appendix

Options: None

Purpose:

Generation of flexible command/data output structures when NPC-800C is the controller.

Return Code:

GPIB.RET% equals 0 if command is executed correctly; otherwise one or more error bits are set as follows:

	ERROR DEFINITION
Bit 0 —	Not active controller
Bit 1 —	Not used
Bit 2 —	Timeout
Bit 3 —	Not used
Bit 4 —	NPC-800C is not a TALKER

3.19.73 TERMINATION SEQUENCE

Statement Format:

STMT NUMBER GPIB.RET% = FN.TERM.SEQ%(DATA)

Parameters:

DATA contains desired ASCII sequence to signify end of data string on OUTPUT and ENTER.

Options:

1. DATA = NULL (CR/LF is used).
2. DATA = "E" (EOI is forced on last data byte).
3. First character of DATA = ":" forces EOI on last byte of termination sequence.

Purpose: Definition of alternate data terminators for OUTPUT and ENTER.

Return Code: Not used.

NOTE

ABORT.GPIB (or INIT.GPIB) resets termination sequence to CR/LF.

3.19.74 Address/Data Formats For CBASIC

FUNCTION	C*	D*	Statement Format
Initialize	X	X	GPIB.RET% = FN.ABORT GPIB%
Abort/Take Control	X		GPIB.RET% = FN.ABORT.GPIB%
Device Clear	X		GPIB.RET% = FN.RESET%("")
Selected Device Clear	X		GPIB.RET% = FN.RESET%(ADDRESS.LIST\$)
Go To Local-All	X		GPIB.RET% = FN.LOCAL%("")
Go To Local-Device	X		GPIB.RET% = FN.LOCAL%(ADDRESS.LIST\$)
Set NPC-800C To Local		X	GPIB.RET% = FN.LOCAL%("")
Lock NPC-800C in Local		X	GPIB.RET% = FN.LOCAL%("L")
Remote Enable	X		GPIB.RET% = FN.REMOTE%("")
Set Device to Remote	X		GPIB.RET% = FN.REMOTE%(ADDRESS.LIST\$)
Device Status	X		DUMMY.VARIABLE\$ = FN.STATUS\$(ADDRESS)
Configuration Status	X		STATUS.VARIABLE\$ = FN.STATUS\$("")
Bus Status	X	X	STATUS.VARIABLE\$ = FN.STATUS\$("B")
Group Execute Trigger	X		GPIB.RET% = FN.TRIGGER%(ADDRESS.LIST\$)
Request Service		X	GPIB.RET% = FN.REQUEST%(STATUS.BYTE%)
Output Data	X		GPIB.RET% = FN.OUTPUT% (ADDRESS.LIST\$,DATA\$)
Output Data		X	GPIB.RET% = FN.OUTPUT%("",DATA\$)
Input Data	X		DATA.VARIABLE \$ = FN.ENTER%(ADDRESS\$)
Input Data	X	X	DATA.VARIABLE \$ = FN.ENTER%("")
Local Lockout	X		GPIB.RET% = FN.LOCAL.LOCKOUT%
Set Timeout	X	X	DUMMY% = FN.SET.TIMEOUT%(TIME%)
Configure	X		GPIB.RET% = FN.CONFIGURE%(ADDRESS\$, ADDRESS.LIST\$)
EOI Status	X		GPIB.RET% = FN.EOI.STATUS%
Sendbus	X		GPIB.RET% = FN.SEND.BUS% (COMMAND.DATA\$)
Termination Sequence	X	X	GPIB.RET% = FN.TERM.SEQ%(TERM\$)

*C - CONTROLLER mode

*D - DEVICE mode

3.19.75 ADDRESS\$

The primary GPIB bus address (range 00-30) of one bus device can be followed by any number of secondary commands (range 00-31). A decimal point is used to separate each address/command.

Examples: 25
12.15
04.31.09

3.19.76 ADDRESS.LIST\$

Up to 15 GPIB devices can be specified, using the format for address\$. Device addresses are separated by a comma.

Examples: 12,15,04,31,09
 23
 10,15,20,25

3.19.77 DATAS

Output data string to device(s). Can be any valid ASCII expression.

3.19.78 DATA.VARIABLES

Name of ASCII variable which contain data after an ENTER.

3.19.79 STATUS.BYTE%

A byte which is returned to the controller in response to a serial poll. Setting bit 6 sets SRQ to request service from the controller.

3.19.80 STATUS.VARIABLES

For FN.Status\$("A?") this variable is 31 characters long, each character corresponding to a bus address, 0-30, where:

N = No device present
 P = Device present
 S = Device has requested service

For FN.Status\$("B") the character positions are defined as follows:

1. My address (in binary)
2. Address status (used primarily when NPC-800C is bus device)

BIT: 0-TADS or TACS (addressed to talk)
 1-LADS or LACS (addressed to listen)
 4-ATN is true
 5-LLO is on
 6-In remote state

3. TALK/LISTEN/CONTROL Status

BIT: 0-Device mode
 1-Active/System controller
 2-Controller enabled
 3-Listen enabled
 4-Talk enabled

3.19.81 CBASIC Reserved Identifiers

The following Reserved Variable Identifiers should not be used in application programs because they are used in the GPIB software interface :

FN.ABORT.GPIB%	FN.OUTPUT%
FN.CALL.GPIB%	FN.PARM.LOC%
FN.CONFIGURE%	FN.REMOTE%
FN.ENTERS\$ FN.EOI.STATUS%	FN.REQUEST%
FN.GPIB.ASM%	FN.RESET%
FN.INIT.GPIB%	FN.SEND.BUS%
FN.LOCAL%	FN.SET.TIMEOUT%
FN.LOCAL.LOCKOUT%	FN.STATUS\$ FN.TERM.SEQ%
FN.MAXGPIB.TIME%	FN.TRIGGER%

3.19.82 Direct Use of GPIB Primitives

1. Before calling a command, these locations must first be loaded with appropriate data:

E000 LSB of starting address of GPIB ADDRESS LIST
 E001 MSB of starting address of GPIB ADDRESS LIST
 E002 LSB of starting address of DATA string
 E003 MSB of starting address of DATA string
 E006 Command Branch Index
 E007 Command Control Word

2. Execute a call to location F842 HEX.
3. After execution, return code is in locations E008 (LSB) and E009 (MSB).
4. Only the stack is preserved, registers are destroyed.

NOTE

See Section 3.19.47 for data formats of each parameter in 1, above. For the REQUEST command, the binary data is passed in place of the DATA string address.

3.19.83 Address/Data Formats For Assembler Primitives

ADDRESS:

First location is length of ADDRESS LIST (1-255). Each subsequent location contains a TALK, LISTEN or secondary address.

3.19.84 BIT

4-0 Binary Device Address
 6-5 Address Type: 01 = LISTEN
 10 = TALK
 11 = SECONDARY

All commands can use any combination of LISTEN and secondary addresses, except ENTER and STATUS, which can have one TALK address and any number of secondary addresses.

3.19.85 DATA (Bus Status)

The first location contains string length, which is always 3. The next location contains MA, in binary. The third location contains MA status. This location is primarily of interest when the NPC-800C is a bus device. The fourth location contains the system mode.

BUS STATUS

- Bit 0 — Addressed to TALK (TADS or TACS)
- Bit 1 — Addressed to LISTEN (LADS or LACS)
- Bit 4 — ATN is true
- Bit 5 — LLO is active
- Bit 6 — In remote state

SYSTEM MODE

- Bit 0 — Device
- Bit 1 — Controller
- Bit 4-2 — TLC Mask

3.19.86 Command Branch Index

A binary number from command-selected index (from Branch Table).

- 0 = Abort/Init
- 1 = Selected Device Clear (alternate command is Device Clear)
- 2 = Go To Local (alternate command sets REN false)
- 3 = Local-Lock
- 4 = Go To Remote (alternate command sets REN true)
- 5 = Device Status
- 6 = Bus Status
- 7 = Trigger
- 8 = Request
- 9 = Output
- 10 = Enter
- 11 = Local Lockout
- 12 = Configure
- 13 = Sendbus
- 14 = EOI Status
- 15 = Set Termination Sequence

3.19.87 Command Control Byte

ERROR DEFINITION

- Bit 0 — 0 = Byte mode; 1 = Word mode
- Bit 1 — 0 = Listen Address; 1 = Talk Address
- Bit 2 — Address conversion required
- Bit 3 — Alternate command select (equivalent to NULL Address mode of CBASIC command description)

- Bit 4-5 — Required controller status:
 - 00 = Don't Care
 - 01 = Must be device
 - 10 = Must be controller
 - 11 = Must be controller if alternate command is not selected
- Bit 6 — Must be LISTENER
- Bit 7 — Must be TALKER

3.19.88 Return Code

ERROR DEFINITIONS

- Bit 0 — Incorrect controller status
- Bit 1 — NPC-800C is device and not addressed to TALK/LISTEN
- Bit 2 — Timeout
- Bit 3 — Not used
- Bit 4 — Not a TALKER/LISTENER
- Bit 5 — Input data have been truncated to length of data string

DEFINITION FOR BUS STATUS

- Bit 0 — REN is true
- Bit 1 — IFC is true
- Bit 2 — SRQ is true
- Bit 3 — EOI is true
- Bit 4 — NRFD is true
- Bit 5 — NDAC is true
- Bit 6 — DAV is true
- Bit 7 — ATN is true
- Bit 8 — IFC has occurred
- Bit 9 — SRW has occurred
- Bit 10 — MA has occurred
- Bit 11 — DCL has occurred
- Bit 12 — Not used
- Bit 13 — Unidentified command has occurred
- Bit 14 — Incomplete handshake has occurred
- Bit 15 — GET has occurred

EXCEPTIONS

- FOR ABORT.GPIB:
 - 0 = Controller
 - 1 = Device
- FOR EOI STATUS:
 - 0 = EOI has not occurred
 - 8 = EOI has occurred
- FOR DEVICE STATUS: Device status byte (STB) is in MSB of return code.

3.19.89 Level of GPIB Implementation

The following table provides a summary of the implementation level of those functions described in document: ANSI/IEEE Std. 488-1978.

Identification	Description	Notes
SH1	Source Handshake	
AH1	Acceptor Handshake	
T6	Talker	TO when TALK is off
TEO	Extender Talker	
L4	Listener	LO when LISTEN is off
LEO	Extender Listener	
SR1	Service Request	
RL1	Remote Local	
PPO	Parallel Poll	
DCO	Device Clear	
DTO	Device Trigger	
C1	Controller	CO when DEVICE
C2	Controller	CO when DEVICE
C3	Controller	CO when DEVICE
C4	Controller	CO when DEVICE
C27	Controller	CO when DEVICE

3.19.90 Command Formats

1. MENU COMMANDS

GPIB commands to setup the NPC-800C generally follow the same format and sequence used when commanding the NPC-800C from the keyboard. ASCII characters are used for all commands. The actual definition of each ASCII character depends on menu that is currently being displayed. See Section 3.20.31 for soft-key definitions and Table 3-2 for command formats and field definitions.

2. BUS COMMANDS

In addition to MENU COMMANDS, a set of BUS COMMANDS is available to enhance the external control features of the NPC-800C (see Table 3-3 for a summary of these commands).

3. IEEE-488 (GPIB)

For GPIB operation, command strings are limited to 80 bytes. All command strings must end in the correct termination sequence (which is programmable in the NPC-800C). Only one BUS COMMAND is allowed in a command string, and it must be the last one specified. For burst commands, data must follow command string termination sequence. There are no limits to length of data portion of a burst command.

3.19.91 Commands That Return Data

Table 3-3 contains a summary of all commands which return data from the analyzer. Some commands are returned as several strings of ASCII characters on the IEEE-488 bus; each terminated with a Carriage Return/Line Feed. Data are ASCII-encoded HEX: therefore the

number of characters transmitted will be twice the number of data bytes shown in Table 3-4.

Table 3-2. Command Formats and Field Definitions

Format Number	Format	Field Definitions
1	A CRLF	Keyboard Commands
2	A CRLF	Bus Commands
3	A HXHX CRLF	Address
4	A HXHX DDDD CRLF	Number of Hex Pairs Address
5	A HXHX HX CRLF	Data Address
6	A CRLF AAA... CRLF	ASCII Data

NOTE

For the NPC-800C, CRLF is the GPIB termination sequence. Each time an FN.OUTPUT function is executed from CBASIC, the termination sequence is transmitted automatically by the NPC-800C.

HX = Hexadecimal Pair (i.e., 0F)
D = Decimal Digit
A = ASCII Character

Table 3-3. NPC-800C Command List (Other than Keyboard Commands)

Command	Description	Format Number
>0	Initialize All	2
>1	Initialize Logic Analyzer (excluding I/O menu)	2
>2	Lock Keyboard	2
>3	Unlock Keyboard	2
>4	Clear CRT	2
>5	CONFIGURATION LIST	2
>6	CONFIGURATION LIST-SELECT 48 CHANNEL STATE	2
>7	Not Used	2
>8	Not Used	2
>9	Collect	2
>A	Read State Setup	*6
>B	Read State Data to Aux Memory	*6
>C	Same as above	*6
>D	Read Timing Setup	*6
>E	Read Timing Data to Aux Memory	*6
>F	Same as above	*6
>G	Dump State Setup	2
>H	Dump State Data	2
>I	Dump State Aux	2
>J	Dump Timing Setup	2
>K	Dump Timing Data	2
>L	Dump Timing Aux	2
>M	Dump Collection Status	2
>N	Dump Signatures	2
>P	Dump Collection Variables	2
>Q	Dump State Probe A Data	4
>R	Dump State Probe B Data	4
>S	Dump State Probe C Data	4
>T	Dump Timing Data	4
>U	Dump Screen to RS-232 Device	2
>V	Dump Byte from Memory to Output Device	3
>W	Write Byte to Memory from Input Device	5
>X	Set CRT Cursor Position	3
>Y	Write to CRT From Input Device	*6
>Z	Dump Screen to CRT of Remote NPC-800C over RS-232	

* Burst Commands

Table 3-4. Command Formats

Input Command	Output Command	String Number	Length (Bytes)	Description
A	G	1	713	State Setup and Configuration
B	H	1	413	State Setup
		2	12	State Display Parameters
		3	6144	State Data
C	I	1	413	State Aux Setup
		2	12	State Aux Display Parameters
		3	6144	State Aux Data
D	J	1	312	Timing Setup
E	K	1	30	Timing Display Parameters
		2	12	Timing Display Parameters
		3	2	Location of First Data Word
		4	1	Collection Status
		5	2048	Timing Data
F	L	1	30	Timing Aux Display Parameters
		2	12	Timing Aux Display Parameters
		3	1	Timing Aux Display Status
		4	2048	Timing Aux Data
	M	1	2	Collection Status
	N	1	20	Test Codes: 6 - State 4 - Timing 6 - Aux State 4 - Aux Timing
				2 - State Trigger Displacement 2 - State Word Count 2 - Timing Trigger Displacement 2 - Timing Word Count
P		1	8	2 - State Trigger Displacement 2 - State Word Count 2 - Timing Trigger Displacement 2 - Timing Word Count
Q	HXHXDDDD	1	DDDD	State Probe A MSB
		2	DDDD	State Probe A LSB
R	HXHXDDDD	1	DDDD	State Probe B MSB
		2	DDDD	State Probe B LSB
S	HXHXDDDD	1	DDDD	State Probe C MSB
		2	DDDD	State Probe C LSB
T	HXHXDDDD	1	DDDD	Timing Probe A
		2	DDDD	Timing Probe B

NOTE

Each logic analyzer byte below (8 bits) is divided into two 4-bit nibbles. An ASCII equivalent byte is then sent for each nibble.

3.19.92 Command Definitions

The following definitions apply to the NPC-800C commands that can be executed from an external controller (either another NPC-800 or a dedicated GPIB CONTROLLER). If the controller is another NPC-800, to avoid local response to commands, the TRANSMIT field of the controller's I/O menu must be ON (see Table 3-4 for command formats).

0 - Initialize All of NPC-800C

This command performs the same function as a power-up reset. All analysis parameters and data are reset, CP/M operating system is reset, and GPIB bus is also reset (Interface Clear is set).

1 - Initialize Analyzer

This command performs the same functions as the 0 command, except for the CP/M operating system and the GPIB bus. Thus, this command can be sent to the internal analyzer from a CP/M program to initialize only the analyzer; the rest of the system is left intact.

2 - Lock Keyboard

This command sets a flag which prevents access to the NPC-800C by unauthorized users at the keyboard.

NOTE

The slave NPC-800C keyboard cannot be locked while in the I/O menu on the master. The user can only execute this function from CP/M or while in the analyzer proper (menu's or data display).

3 - Unlock Keyboard

This command resets the Lock Keyboard flag and restores keyboard access.

4 - Clear CRT

This command causes NPC-800C to blank its CRT. Normally used in conjunction with the Y command, it sends messages to an operator when the NPC-800C is under automatic control.

5 - CONFIGURATION LIST

This command provides a convenient method of calling the NPC-800C's Configuration List.

6 - CONFIGURATION LIST-SELECT 48 CHANNEL STATE

This command calls the Configuration List and sets the cursor at the 48 CHANNEL STATE mode.

7 - DUMP CT/SA VALUE (up to 24 bytes)

8 - NOT USED

9 - COLLECT

This command has the same function as the COLLECT key, but can be executed from any menu.

A - READ STATE SETUP

This command is used to read data into state menu.

B,C - READ STATE DATA

These commands are used to read data into State Aux Memory.

D - READ TIMING SETUP

This command is used to read data into timing menu.

E,F - READ TIMING DATA

These commands are used to read data into Timing Aux Memory.

G - DUMP STATE SETUP

This command is used to dump State Analyzer's setup.

H - DUMP MAIN STATE DATA

This command is used to dump State Analyzer's Main Memory Data.

I - DUMP AUX STATE DATA

This command is used to dump State Analyzer's Aux Memory Data.

J - DUMP TIMING SETUP

This command is used to dump Timing Analyzer's setup.

K - DUMP MAIN TIMING DATA

This command is used to dump Timing Analyzer's Main Memory Data.

L - DUMP AUX TIMING DATA

This command is used to dump Timing Analyzer's Aux Memory Data.

M - DUMP COLLECTION STATUS

This command is used to dump the Analyzer's Collection Status. If not collecting, then dump one byte for the state analyzer and one byte for the timing analyzer.

N - DUMP SIGNATURES

Dump Signatures (20 bytes): A,B,C, Main State Memory; A,B, Main Timing Memory; A,B,C, Aux State Memory; and A,B, Aux Timing Memory Signatures.

Q - NOT USED

This command is not used.

P - DUMP COLLECTION VARIABLES (16 bytes)

This command provides a State Word Count (4 bytes) and a Trigger Displacement (4 bytes); a Timing Word Count (4 bytes) and a Trigger Displacement (4 bytes).

QXXXXYYYY - DUMP STATE A PROBE DATA

This command is used to dump State A Probe data with most significant bytes followed by least significant bytes, where XXXX = start of dump displacement from first word collected and YYYY = word count to dump.

RXXXXYYYY - DUMP STATE B PROBE DATA

See Q command above.

SXXXXYYYY - DUMP STATE C PROBE DATA

See Q command above.

TXXXXYYYY - DUMP TIMING A & B PROBE DATA

This command dumps A Timing Probe data bytes followed by B Timing Probe data bytes. See Q command above.

U - DUMP SCREEN TO RS-232 DEVICE

Vaaaa - SINGLE BYTE MEMORY DUMP

This command is used to dump the byte at HEX address to enabled output ports.

Waaaabb - SINGLE BYTE MEMORY WRITE

This command writes byte bb to address aaaa.

Xpppp - SET SCREEN CURSOR POSITION

This command is used to set cursor position to relative value pppp in decimal (0-1999).

Yddd..dd\$ - WRITE TO SCREEN

This command is used to write data ddd... to the screen cursor location. Terminate data with \$. Screen RAM begins at F000(HEX) and ends at F7CF(HEX).

Z - SCREEN DUMP TO REMOTE NPC-800C

This command is used to dump a CR and a LF followed by the first 25 lines of the screen to the RS-232C port, if enabled.

3.19.93 Transmission Examples (NPC-800C ONLY)

These examples demonstrate use of NPC-800C's I/O CONFIGURATION menu.

3.19.94 Analyzer Data Transmission

In this example, the transfer of blocks of analyzer data from one NPC-800 to another is demonstrated.

SETUP

Using GPIB bus connectors at rear of unit, connect one NPC-800 to another NPC-800.

For both units, perform the following sequence: turn power switch on or press RESET to produce CONFIGURATION LIST. Then press I key to call the I/O CONFIGURATION MENUS.

3.19.95 Controller (Master)

For unit selected to be the CONTROLLER, the I/O menu is set up in following steps with default values in all fields except GPIB INTERFACE (ENABLED), GPIB MODE (CONTROLLER), MEMORY INPUT (TIMING SETUP), and GPIB OUTPUT (ENABLED). After making sure that GPIB INTERFACE field is enabled, advance cursor to GPIB mode field using NEXT key. If field is set to DEVICE, press SELECT key to set it to CONTROLLER. Access TRANSMISSION INPUT field by pressing I key. Then advance cursor to MEMORY field by pressing NEXT key. Press SELECT key twice to set memory to TIMING SETUP. Then use O key and NEXT key to access GPIB OUTPUT field. Use SELECT key to turn this field ON.

Press CONFIG key to call CONFIGURATION LIST. Select 16-CHANNEL TIMING mode by pressing SEL DOWN key. Call menu with TIMING key. Arbitrarily change two or three of the parameters in the menu.

Press CONFIG key to call CONFIGURATION LIST again. Select I/O CONFIGURATION MENU by pressing I key. At this point, the first NPC-800 (CONTROLLER) is ready to send the timing menu to second NPC-800 (DEVICE) over the GPIB bus (see Figure 3-100).

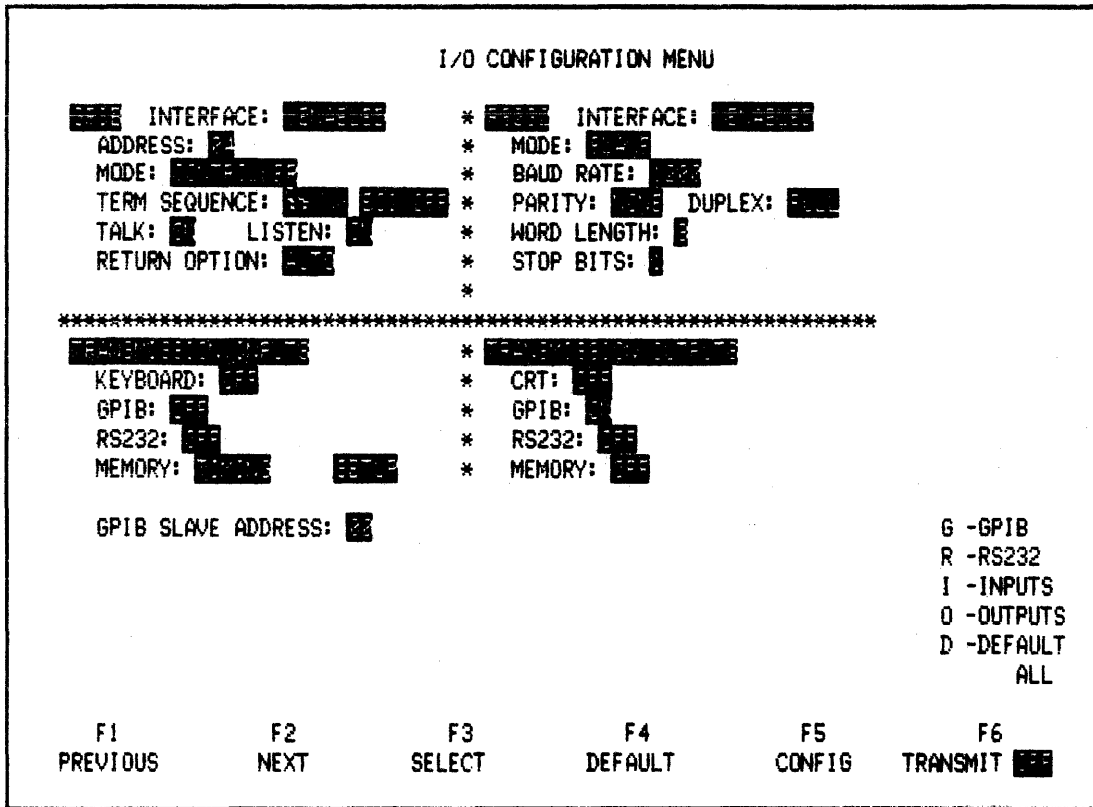

Figure 3-100. I/O Menu For Transmitting Timing Menu To An NPC-800 (acting as DEVICE on GPIB bus)

3.19.96 Device (Slave)

When the NPC-800C acts as a DEVICE, the I/O menu should be set up as shown in Figure 3-101 Notice that DEVICE is selected, DEVICE ADDRESS is set to 00* (using SELECT key), and GPIB INPUT field is ON. At this point, the second NPC-800 is ready to receive the timing menu over the GPIB bus.

* Thirty device addresses are available.

```

                                I/O CONFIGURATION MENU

* 16-CHANNEL INTERFACE: ENABLED * RS232C INTERFACE: ENABLED
  ADDRESS: 00 * MODE: RS232C
  MODE: RS232C * BAUD RATE: 19200
  TERM SEQUENCE: LF * EOL: OFF * PARITY: NONE DUPLEX: FULL
  TALK: ON LISTEN: ON * WORD LENGTH: 8
  RETURN OPTION: CR * STOP BITS: 1
  *
  *
  *****
  RECEPTION CHANNEL INPUTS * TRANSMISSION CHANNEL OUTPUTS
  *
  KEYBOARD: OFF * CRT: OFF
  GPIB: ON * GPIB: OFF
  RS232C: OFF * RS232C: OFF
  MEMORY: OFF * MEMORY: OFF
  *
  *
  G - GPIB
  R - RS232C
  I - INPUTS
  O - OUTPUTS
  D - DEFAULT
  ALL

F1          F2          F3          F4          F5          F6
PREVIOUS    NEXT        SELECT      DEFAULT    CONFIG     TRANSMIT OFF

```

Figure 3-101. I/O Menu For Receiving Timing Menu from another NPC-800C

Return to NPC-800C you set up as a CONTROLLER and press TRANSMIT key to turn field ON. Message DONE will flash on the NPC-800C (acting as a DEVICE when transmission is complete; TIMING SETUP data have been transferred from CONTROLLER.)

To get back to CONFIGURATION LIST, press CONFIG key on second NPC-800 (DEVICE). Select 16-CHANNEL TIMING mode by pressing SEL DOWN key. Call menu with TIMING key. Parameters that were changed in CONTROLLER are also changed in the DEVICE.

3.19.97 MORE I/O EXAMPLES

To further illustrate the instrument's GPIB CONTROLLER/DEVICE capabilities, your NPC-800C's diskette contains a CBASIC program. Called GPIBEX, this program does not require any programming. Through easy-to-use menus, you can control another instrument and transfer data.

3.19.98 Source

By typing: TYPE GPIBEX.BAS., the program listing is available on diskette. This listing will be of interest to users who want to modify these programs for their own application. Type CNTL S to stop screen from scrolling: type any key to start.

3.19.99 GPIBEX

The GPIBEX program allows you to exercise an external GPIB-compatible instrument, or

control your NPC-800C's internal analysis functions. In the following example, the internal 48-Channel State Analyzer is exercised by the Controller, as if it were an independent instrument on the GPIB bus:

Procedure

1. To call CP/M operating system, insert diskette and press ESC. Type DIR and RETURN to make certain GPIBEX program is on your diskette (contact factory or your nearest sales office if program is not on your diskette).

CRUN2 OR CRUN23 GPIBEX

2. Type CRUN2 GPIBEX OR CRUN23 GPIBEX (RETURN). When main menu is displayed after a short delay, select LOGIC ANALYZER COMMAND menu (Option 2) as shown in Figure 3-102.

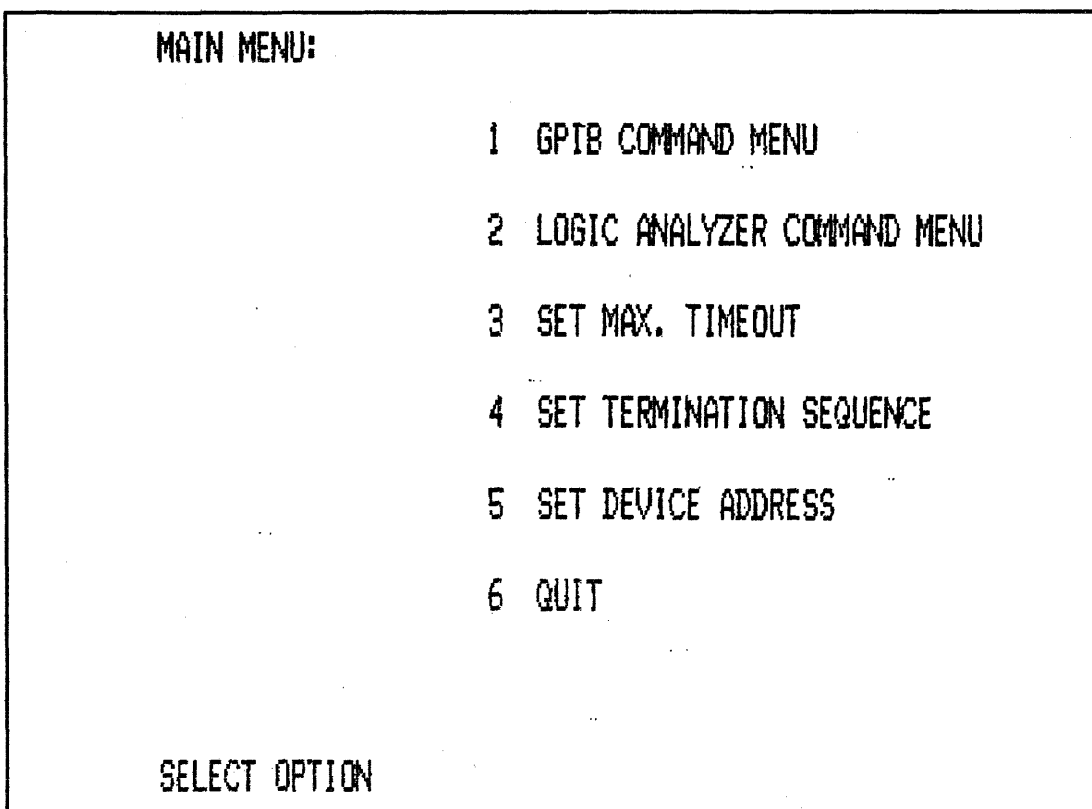

Figure 3-102. Main Menu

Command Menu

3. After pressing RETURN, the LOGIC ANALYZER COMMAND menu is displayed. Select Option: SEND COMMAND TO LOGIC ANALYZER (Option 1) as shown in Figure 3-103.

```
LOGIC ANALYZER COMMAND MENU:

      1 SEND COMMAND TO LOGIC ANALYZER

      2 SEND SOFT-KEY COMMAND TO LOGIC ANALYZER

      3 GO TO LOGIC ANALYZER

      4 LASAVE

      5 LARECALL

      6 GO TO MAIN MENU

SELECT OPTION
```

Figure 3-103. Logic Analyzer Command Menu

NOTE

Selecting Option 1 automatically sets device address for NPC-800C's internal analysis functions.

4. Press RETURN to call header: ENTER COMMAND STRING.

NOTE

In this program, you can only enter one command or menu field setup at a time (see Section 3.19.91 and 3.19.92 for command formats and definitions). Use correct formats; otherwise software may return you to the analyzer operating system (or possibly crash) and the above procedure will have to be repeated from step 1.

5. Type 1 (RETURN) to initialize analyzer and display CONFIGURATION LIST. Then press RETURN to call command menu, as indicated by message on bottom of CRT.
6. Select Option 2 to send a soft-key command and press RETURN. When header: SELECT SOFT-KEY (1-6) appears, type 1 to select F1 (STATE) function which calls the state menu.

7. Observe that the state menu is displayed with cursor in FORMAT field. Call command menu and type 1 and RETURN. When command string header appears, type in 16 As, 16 Bs, and 16 Xs (see Figure 3-104). Next, press RETURN.

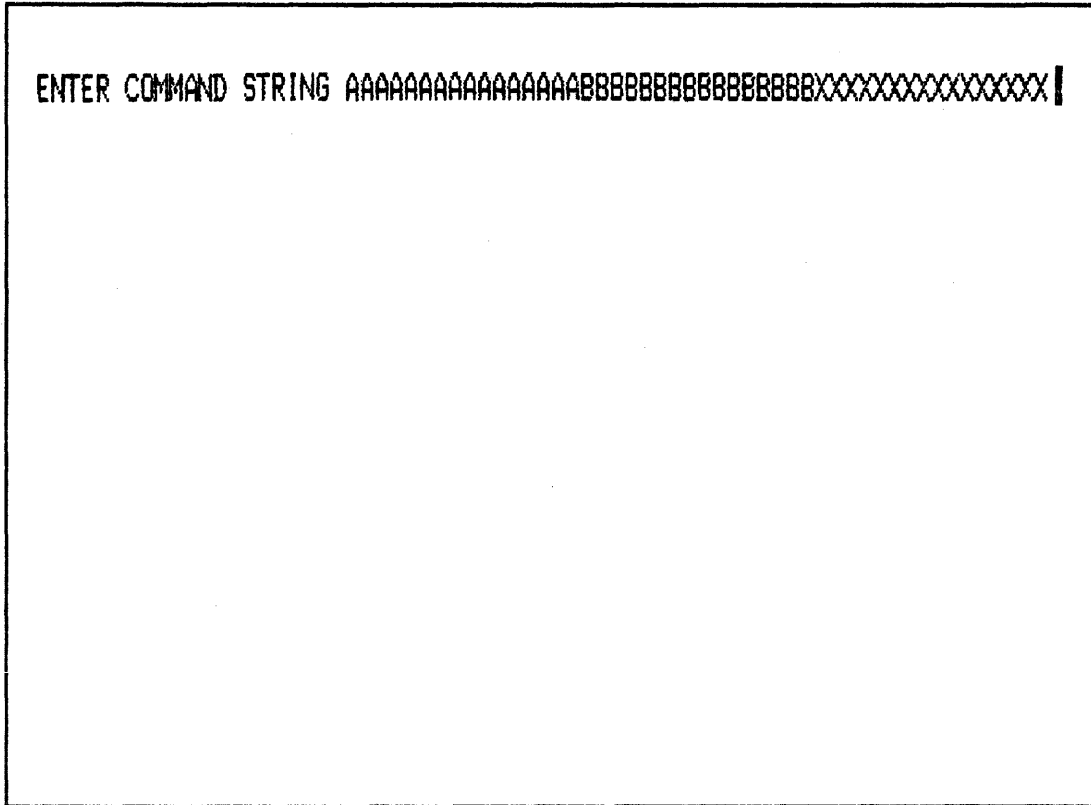

Figure 3-104. Setting Up State Format Field

8. The state menu carries out format command as soon as RETURN is pressed. If you want A and B FORMAT fields to be set to hexadecimal and binary, respectively, call command menu, select Option 1, and simply type: HN.
9. Next, trigger word is set up; rest of menu is unchanged. To get down to TRIGGER field, press command F2 (NEXT) key five times; call command menu, type 2 (RETURN), and type 2 again (RETURN) - repeat until cursor is in TRIGGER field.
10. For this example, use trigger word 0040. Call command menu, type 1, and type 0040 (RETURN) (see Figure 3-105).

```

                                48 CHANNEL STATE MENU

FORMAT: AAAAAAAAA AAAAAAAAA BBBB BBBB XXXXXXXX XXXXXXXX
        A HEX B BIN
CLK SEL: A PRB: J B PRB: A C PRB: A   QUALIFIERS FORMAT: -AABBCC EL
CLK QUAL: OFF
        OR OFF
PRE-TRIG MEMORY (0-999): 000 WORDS
RESTART: OFF
TRIGGER:
0      0040 XXXXXXXXXXXXXXXXXXXX -XXXXXX XX
MORE

PRESS RETURN TO CONTINUE

```

Figure 3-105. State Menu Set-Up

Collect

11. To take a data collection, first make sure the A state probe is connected to test card. Then return to command menu, type 2, and then type 6 for F6 (COLLECT). Analyzer responds initially with no data displayed. To display data, command the F6 (COLLECT) key again or select any of the valid display commands (data are displayed by sending a U, USER format, command to the analyzer; see Figure 3-106).

```

MAIN   TRIG 0040 1111111111111111
      +001 0041 1111111111111111
LOC: TRIG +002 0042 1111111111111111
      +003 0043 1111111111111111
SIG: C1E7 +004 0044 1111111111111111
      D8D3 +005 0045 1111111111111111
      D8D3 +006 0046 1111111111111111
      +007 0047 1111111111111111
      +008 0048 1111111111111111
      +009 0049 1111111111111111
      +010 004A 1111111111111111
      +011 004B 1111111111111111
      +012 004C 1111111111111111
      +013 004D 1111111111111111
      +014 004E 1111111111111111
      +015 004F 1111111111111111
      +016 0050 1111111111111111
      +017 0051 1111111111111111
      +018 0052 1111111111111111
      +019 0053 1111111111111111

STATE: DONE

          RETURN-DISK SYS   LABELS   RETURN-DISK
F1       F2       F3       F4       F5       F6
SCRL DWN SCRL UP   LOCATE  SRCH WRD  CONFIG  COLLECT  RD

```

Figure 3-106. Corresponding State Display

Direct

- Once data are displayed, you can rapidly access a desired field of the state menu by sending a direct entry command, such as P (PRETRIGGER).

NOTE

S1 or S2 (DATA DISPLAY) function is not available in the GPIBEX program.

Experiment with other portions of the GPIBEX program using state or other NPC-800C internal analyzer functions. This program is useful for examining the operation of external GPIB instruments.

3.20 RS-232C REMOTE LOGIC ANALYSIS

The NPC-800C provides logic analysis capabilities for virtually every application. For example, in field service, an engineer is sent into the field with a logic analyzer to perform system-level troubleshooting. If assistance is needed from his home office, he simply connects the NPC-800C to a modem to permit remote control.

Using the RS-232C port, which is similar to IEEE-488 control, the NPC-800C allows full control of the logic analyzer. In fact, most commands are the same for either RS-232C or IEEE-488 control, they simply enter the NPC-800C on different ports.

This section provides command structure definitions, illustrating an example of one NPC-800 controlling another NPC-800, linked by an RS-232C cable.

3.20.1 Computer Control Via RS-232C

A second example illustrates how the NPC-800C can be controlled by a personal computer (actually another NPC-800), that uses a program written in CBASIC, and sending commands via the RS-232C port.

3.20.2 Interface Connections

The connection uses standard EIA levels of ± 12 volt amplitude (positive true logic) and are described in the following list (unlisted pin numbers are not used by the NPC-800C).

3.20.3 RS-232C Pin Definitions

- PIN 1 — Chassis and Logic Ground.
- PIN 2 — Serial In; Disk/RAM Controller (DRC) board can be “strapped” to configure this pin as Serial Out.
- PIN 3 — Serial Out; Disk/RAM Controller (DRC) board can be “strapped” to configure this pin as Serial In.
- PIN 4 — Return to Send (RTS). (Programmable). Upon power-on reset, RTS is normally “ON.”
- PIN 5 — Clear to Send (CTS). If data are transmitted to NPC-800C, this pin must be pulled up so that if disconnected, it is normally high (ON).
- PIN 6 — Data Set Ready (DSR). Status bit DSR is readable, if desired, and is pulled up so it is normally high (ON).
- PIN 7 — Logic Ground.
- PIN 8 — Data Carrier Detect (DCD). Status bit DCD is readable, if desired, and is pulled up so it is normally high (ON).
- PIN 20 — Data Terminal Ready (DTR). Programmable DTR is driven by software and is normally (ON).

All other pins are disconnected. “Pulled high” means the pin is tied to +15 volts through a resistor.

3.20.4 Interface Configuration

The RS-232C interface is implemented using a Rockwell (Synertek) 6551A chip. This chip is user-programmable to suit desired interface conditions.

The NPC-800C interfaces to other RS-232C compatible equipment. Refer to the 6551A chip manufacturer's data manual (Rockwell/Synertek).

3.20.5 Control Register Command Register

The control register selects the mode of the chip with regard to word length, number of stop bits and clock controls. The command register is used to control specific transmit/receive

functions. These are programmed automatically when power is initially applied, and are set up in accordance to the dip switch located on the Processor Board (in card cage) inside the NPC-800C as shown in Figure 3-107 (see Figure 3-108 for dip switch settings).

NOTE

Default condition for CHARACTER LENGTH is 8 bits with 1 STOP bit. Parity is disabled.

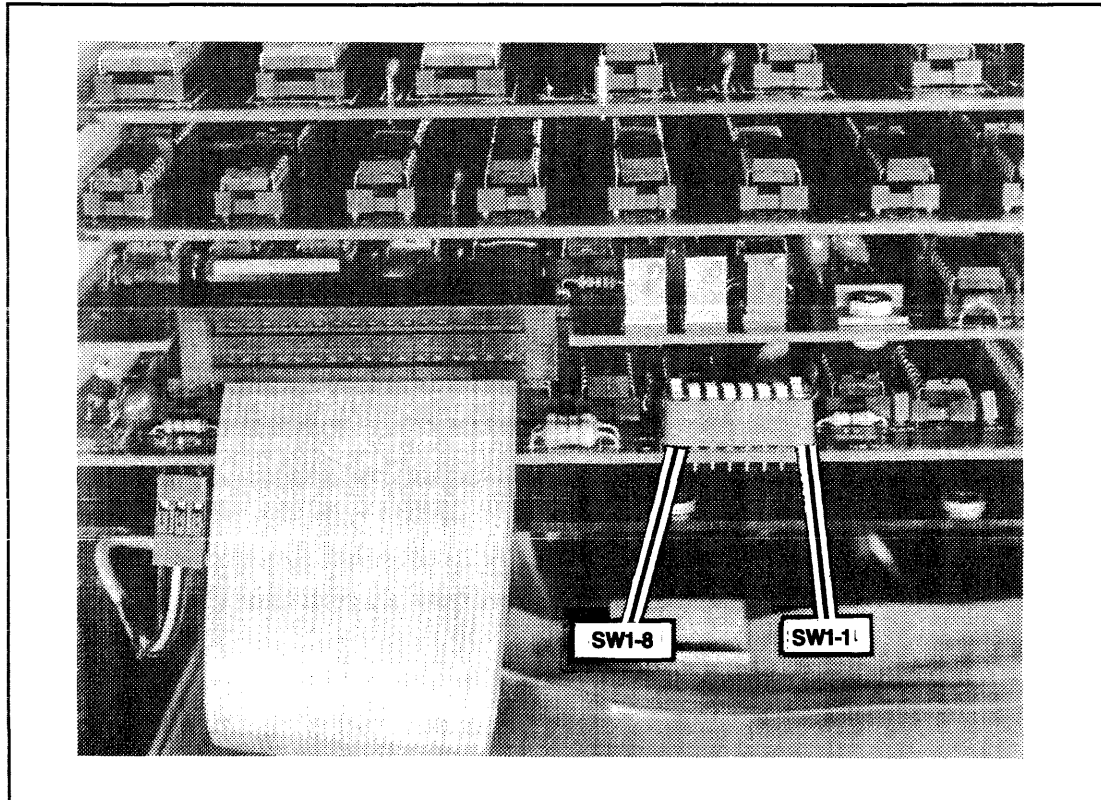

Figure 3-107. Dip Switch Location On Processor Board

3.20.6 RS-232C Setup

RS-232C interface is set up from keyboard using I/O configuration menu (see Section 3.20.10).

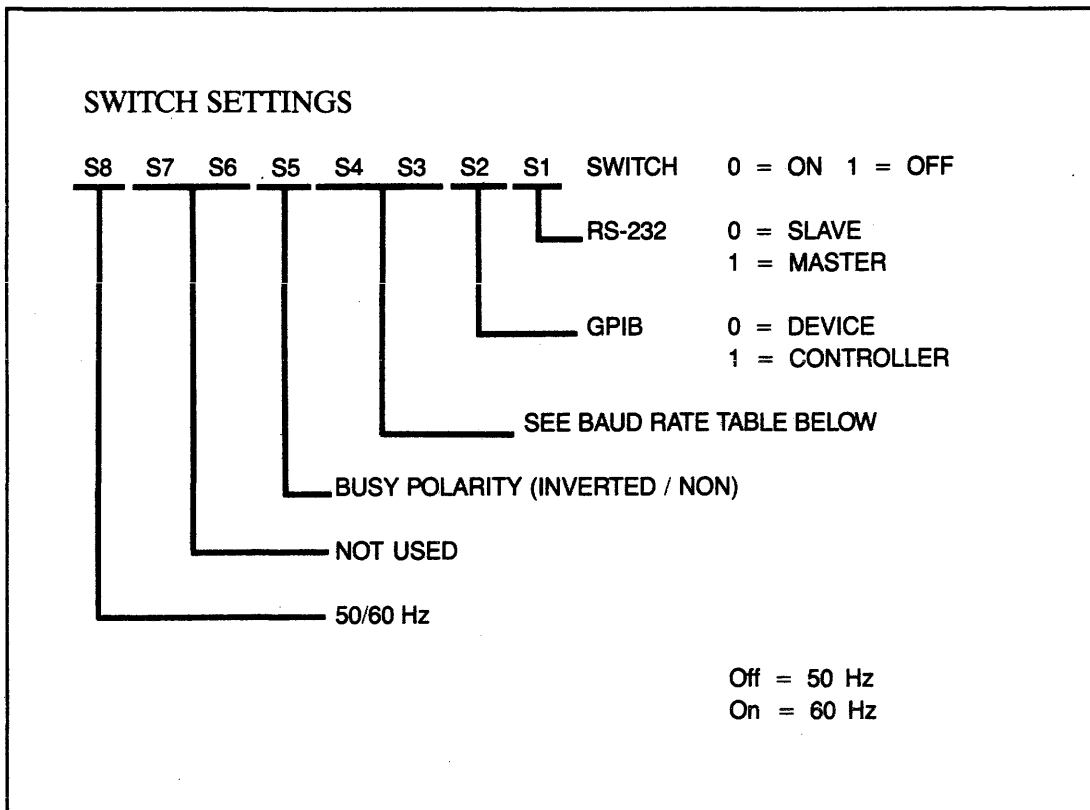

Figure 3-108. Processor Board DIP Switch Settings

3.20.7 Default Baud Rate

The DIP switch settings for power-on default baud rate are as follows:

S4	S3	BAUD RATE
0	0	300
0	1	1200
1	0	4800
1	1	9600

3.20.8 Remote Control Example

In this example, the NPC-800C communicates with another device over the RS-232 interface. The device should be capable of displaying and transmitting ASCII data (such as a data terminal).

3.20.9 Setup

Connect NPC-800C to terminal using RS-232 interface at rear of analyzer. Ensure terminal is configured as follows:

BAUD RATE	1200
PARITY	NONE
DUPLEX	HALF
WORD LENGTH	8
STOP BITS	1

NOTE

If settings on terminal are not easily changed, NPC-800C's parameters can be changed using RS-232 section of I/O configuration menu.

3.20.10 I/O Configuration Menu

To Call Menu:

1. Press CONFIG or RESET key.
2. Press 1 key.

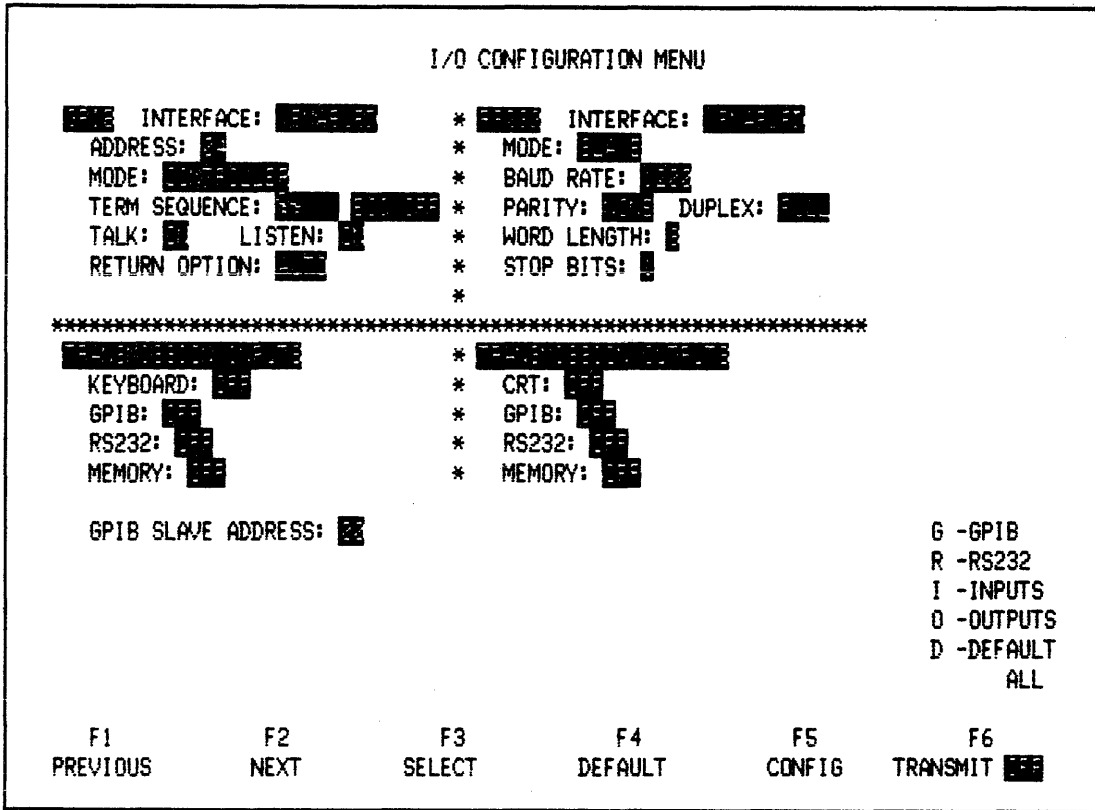

Figure 3-109. I/O Menu

3.20.11 RS-232 Section Interface

The INTERFACE field defaults to ENABLED to allow the NPC-800C to communicate with other devices via an RS-232 bus. After accessing this field, pressing SELECT key puts interface into a DISABLED state which effectively disconnects the device from the bus. If ENABLED mode is selected, the NPC-800C can either be a MASTER or SLAVE on the bus.

3.20.12 Mode

MODE field allows you to reconfigure the NPC-800C to become either MASTER or SLAVE on an RS-232 bus. Default condition is set by switch 1 on DIP switch located on Processor Board (see Figure 3-98). The unit is a MASTER if the switch (S1) is in the OFF position (switch is read during power up and when RESET key is pressed; see Table 3-5). A third mode of operation, MASTER/ECHO, is also available. This mode is identical to MASTER, except that all commands executed by the NPC-800C are echoed from the RS-232 port (except when in I/O configuration menu). This feature is useful when it is desired to set up the MASTER and SLAVE in the same configuration, or to simply see the SLAVE's menus when entering commands manually. The SELECT Key Changes the mode from SLAVE to MASTER to MASTER/ECHO.

The BAUD RATE field defines the RS-232 transmission rate; field defaults to 1200. Use following keys to select desired baud rate:

Table 3-5. Baud Rate Select

KEY	BAUD RATE
1	110
2	150
3	300
4	600
5	1200
6	2400
7	4800
8	9600

NOTE

Above information is displayed on CRT when BAUD RATE field is activated.

3.20.13 Parity

PARITY field defaults to NONE. Pressing SELECT key allows you to set PARITY to NONE, ODD, EVEN, MARK, or SPACE.

3.20.14 Duplex

DUPLEX field defaults to FULL which enables Echo mode for RS-232 interface. Pressing SELECT key allows you to set DUPLEX field to HALF or FULL.

3.20.15 Word Length

WORD LENGTH field defaults to 8. Pressing SELECT key allows you to set WORD LENGTH to 8,7,6, or 5 bits.

3.20.16 Stop Bits

STOP BITS field defaults to 1. Pressing SELECT key allows you to set number of STOP BITS to 1 or 2. Notice that some combinations of parity and word length force the number of stop bits to a specific state. For example, if word length is selected to be 8 and parity is selected, 1 stop bit is sent even though 2 stop bits may have been selected; if word length is 5 and no parity is selected, 1.5 stop bits are sent if 2 stop bits are selected.

3.20.17 Transmission Inputs

This section defines data source(s) that are sent to the interface or memory defined in the TRANSMISSION OUTPUTS section, described below.

3.20.18 Keyboard

KEYBOARD field normally defaults to OFF. The keyboard can only be used to configure and control the analyzer in the OFF state. With OFF cursor flashing, pressing SELECT key turns KEYBOARD field ON to transmit data to interface(s) selected in TRANSMISSION OUTPUTS section.

3.20.19 GPIB

GPIB field normally defaults to OFF. If INTERFACE field in GPIB section of menu is DISABLED, GPIB field is forced to OFF and cannot be changed. With OFF cursor flashing, pressing SELECT key turns this field ON and enables NPC-800C to receive data from another device over the GPIB bus and to send data to destination(s) selected in TRANSMISSION OUTPUTS section.

3.20.20 RS-232

RS-232 field normally defaults to OFF. If INTERFACE field in RS-232 section of menu is DISABLED, RS-232 field is forced to OFF and cannot be changed. With OFF cursor flashing, pressing SELECT key turns this field ON and enables NPC-800C to receive data from another device over RS-232 interface and to send data to destination(s) selected in TRANSMISSION OUTPUTS section.

3.20.21 Memory

MEMORY field normally defaults to OFF. If MODE field in GPIB section is set to DEVICE and mode field in RS-232 section is set to SLAVE, field is forced to OFF and cannot be changed. With OFF cursor flashing, pressing SELECT key provides several combinations of memory data to be transmitted over GPIB or RS-232 interfaces. With field flashing, pressing SELECT key allows you to select TIMING or STATE memory to be transmitted. Pressing NEXT key moves flashing cursor to SETUP field. With SETUP field flashing, pressing SELECT key allows you to select memory type to be transmitted. Choices are SETUP, DATA, or AUX. Pressing DEFAULT key when either field is flashing sets both fields to OFF.

3.20.22 Transmission Outputs Section

3.20.23 CRT

CRT field normally defaults to OFF. CRT displays configuration menus and data collection displays in OFF state. With OFF cursor flashing, pressing SELECT key turns CRT ON to display data received on interface(s) selected in TRANSMISSION INPUTS section.

3.20.24 GPIB

GPIB field normally defaults to OFF. If INTERFACE field in GPIB section of menu is DISABLED, GPIB field is forced to OFF and cannot be changed. With OFF cursor flashing, pressing SELECT key turns this field ON and enables NPC-800C to transmit data to another device over GPIB bus. Data sent are from source(s) selected in TRANSMISSION INPUTS section.

3.20.25 RS-232

RS-232 field normally defaults to OFF. If INTERFACE field in RS-232 section of menu is DISABLED, RS-232 field is forced to OFF and cannot be changed. With OFF cursor flashing, pressing SELECT key turns this field ON and enables NPC-800C to transmit data to another device over RS-232 interface. Data sent are from source(s) selected in TRANSMISSION INPUTS section.

3.20.26 Memory

MEMORY field normally defaults to OFF. If MODE field in GPIB section is set to DEVICE and MODE field in RS-232 section is set to SLAVE, field is forced to OFF and cannot be changed. With OFF cursor flashing, pressing SELECT key provides several memory combinations to receive data from another NPC-800C over interface selected in TRANSMISSION INPUTS section. With field flashing, pressing SELECT key allows you to select TIMING OR STATE memory to receive data. Pressing NEXT key moves flashing cursor to SETUP field. With SETUP field flashing, pressing SELECT key allows you to select memory type to receive data. Choices are SETUP, DATA, or AUX. Pressing DEFAULT key when either field is flashing sets both fields to OFF.

3.20.27 GPIB SLAVE ADDRESS*

GPIB SLAVE ADDRESS field is displayed only if MODE field in GPIB section is set to CONTROLLER. Pressing SELECT key increments address. Valid addresses are 00 through 30 (HEX). The field defines GPIB address of another NPC-800 (or other device*) to which data or memory block are sent as defined in TRANSMISSION INPUTS or OUTPUTS section.

3.20.28 LABELS

These fields are labels that define functions of direct entry keys. Pressing G, R, I, or O moves flashing cursor to associated section of menu. Pressing D sets every field to its default state.

If MEMORY input or MEMORY output is selected, the TRANSMIT key initiates data transmission. The field shows TRANSMIT ON during transmission and changes back to TRANSMIT OFF upon transmission completion.

NOTE

Only one MEMORY (input or output) is allowed to be selected. The other MEMORY is forced to OFF.

3.20.29 MENU Setup

To call the CONFIGURATION LIST, press RESET key and hold it down for at least two seconds. Select I/O CONFIGURATION MENU by pressing I key. Make sure RS-232 INTERFACE field is ENABLED. Advance blinking cursor to KEYBOARD field by pressing I (INPUTS) key. Press SELECT key to enable keyboard inputs (to be transmitted when pressed). To enable NPC-800C to receive data over RS-232 interface, use NEXT and SELECT keys to turn RS-232 INPUT field ON. Advance cursor to CRT field by pressing O (OUTPUTS) key. Press SELECT key to turn this field ON, enabling CRT to display input data. Move blinking cursor to RS-232 OUTPUT field by pressing NEXT key. Press SELECT key to turn this field ON which, in turn, enables data transmission over the RS-232 interface (see Figure 3-110).

* Not used with the RS-232C

```

                                I/O CONFIGURATION MENU

* * * * *
INTERFACE: ENABLED                * * * * * INTERFACE: ENABLED
ADDRESS: 04                       * * * * * MODE: SLAVE
MODE: CONTROLLER                 * * * * * BAUD RATE: 9600
TERM SEQUENCE: 0000000000000000 * * * * * PARITY: NONE DUPLEX: FULL
TALK: 01 LISTEN: 01              * * * * * WORD LENGTH: 8
RETURN OPTION: 0000              * * * * * STOP BITS: 1
* * * * *
*****
TRANSMISSION INPUTS              * * * * * TRANSMISSION OUTPUTS
KEYBOARD: 01                     * * * * * CRT: 01
GPIB: 000                        * * * * * GPIB: 000
RS232: 01                        * * * * * RS232: 01
MEMORY: 000                      * * * * * MEMORY: 000

GPIB SLAVE ADDRESS: 00

G -GPIB
R -RS232
I -INPUTS
O -OUTPUTS
D -DEFAULT
ALL

F1          F2          F3          F4          F5          F6
PREVIOUS    NEXT       SELECT    DEFAULT    CONFIG    TRANSMIT 000

```

**Figure 3-110. I/O CONFIGURATION MENU,
Used To Transmit Keystrokes to Another Device Such as a Terminal**

3.20.30 TRANSMIT

Press TRANSMIT (F6) key. To indicate that transmission and reception are enabled, TRANSMIT key label changes to ON. Type a few characters on NPC-800C keyboard. Notice that characters appear on NPC-800C's CRT, (see Figure 3-100), and on printer or CRT. Now type a few characters on terminal keyboard; characters appear on NPC-800C's CRT.

Press TRANSMIT key again. Key label now changes to OFF. Check RS-232 MODE field. It should be set to SLAVE (if not, use R, NEXT, AND SELECT keys to call SLAVE mode). Type CTRL T on terminal's keyboard; blinking cursor moves to next field (CTRL S moves cursor to previous field). Type an R on terminal keyboard (cursor moves to RS-232 INTERFACE field). In this mode, data or keystrokes from terminal are executed by NPC-800C as if keys on its own keyboard were being pressed.

3.20.31 RS-232

When using NPC-800C's RS-232 interface, there are no command sequence restrictions. Commands are executed as they are input. RS-232 operation requires that electrical interface be set up in accordance with proper pin definitions and that baud rate be matched between NPC-800C and terminal.

For non-ASCII control formats, use conversion table in the Appendix of this manual.

The following commands enable NPC-800C special keys to be controlled remotely from an RS-232 terminal:

NPC-800C Key	Remote Command
S1	CNTL Q
S2	CNTL R
F1	CNTL S
F2	CNTL T
F3	CNTL U
F4	CNTL V
F5	CNTL W
F6	CNTL X
SCREEN DUMP	U or Z

3.20.32 Commands That Return Data

Table 3-6 contains a summary of all commands that return data from the analyzer. Some commands are returned as several strings of ASCII characters on the IEEE-488 bus, each terminated with a Carriage Return/Line Feed. Data are ASCII-encoded HEX: therefore the number of characters transmitted will be twice the number of data bytes shown in Table 3-7.

Table 3-6. Command Formats and Field Definitions

Format Number	Format	Field Definitions
1	A	Keyboard Commands
2	A	Bus Commands
3	A HXHX	Address
4	A HXHX DDDD	Number of Hex Pairs Address
5	A HXHX HX	Data Address
6	A AAA...	ASCII Data

HX = Hexadecimal Pair (i.e., OF)
D = Decimal Digit
A = ASCII Character

Table 3-7. NPC-800C Command List (Other than Keyboard Commands)

Command	Description	Format Number
0	Initialize All	2
1	Initialize Logic Analyzer (excluding I/O menu)	2
2	Lock Keyboard	2
3	Unlock Keyboard	2
4	Clear CRT	2
5	CONFIGURATION LIST	2
6	CONFIGURATION LIST-SELECT 48 CHANNEL STATE	2
7	Not Used	2
8	Not Used	2
9	Collect	2
A	Read State Setup	*6
B	Read State Data to Aux Memory	*6
C	Same as above.	*6
D	Read Timing Setup	*6
E	Read Timing Data to Aux Memory	*6
F	Same as above.	*6
G	Dump State Setup	2
H	Dump State Data	2
I	Dump State Aux	2
J	Dump Timing Setup	2
K	Dump Timing Data	2
L	Dump Timing Aux	2
M	Dump Collection Status	2
N	Dump Signatures	2
P	Dump Collection Variables	2
Q	Dump State Probe A Data	4
R	Dump State Probe B Data	4
S	Dump State Probe C Data	4
T	Dump Timing Data	4
U	Dump Screen to RS-232 Device	
V	Dump Byte from Memory to Output Device	3
W	Write Byte to Memory from Input Device	5
X	Set CRT Cursor Position	3
Y	Write to CRT From Input Device	*6
Z	Dump Screen to CRT of Remote NPC-800C over RS-232	

* Burst Commands

Table 3-8. Command Formats

Input Command	Output Command	String Number	Length (Bytes)	Description
A	G	1	713	State Setup and Configuration
B	H	1	413	State Setup
		3	6144	State Display Parameters State Data
C	I	1	413	State Aux Setup
		2	12	State Aux Display Parameters
		3	6144	State Aux Data
D	J	1	312	Timing Setup
E	K	1	30	Timing Display Parameters
		2	12	Timing Display Parameters
		3	2	Location of First Data Word
		4	1	Collection Status
		5	2048	Timing Data
F	L	1	30	Timing Aux Display Parameters
		2	12	Timing Aux Display Parameters
		3	1	Timing Aux Display Status
		4	2048	Timing Aux Data
	M	1	2	Collection Status
	N	1	20	Test Codes: 6 - State 4 - Timing 6 - Aux State 4 - Aux Timing
	P	1	8	2 - State Trigger Displacement 2 - State Word Count 2 - Timing Trigger Displacement 2 - Timing Word Count
Q	HXHXDDDD	1	DDDD	State Probe A MSB
		2	DDDD	State Probe A LSB
R	HXHXDDDD	1	DDDD	State Probe B MSB
		2	DDDD	State Probe B LSB
S	HXHXDDDD	1	DDDD	State Probe C MSB
		2	DDDD	State Probe C LSB
T	HXHXDDDD	1	DDDD	Timing Probe A
		2	DDDD	Timing Probe B

NOTE

Each logic analyzer byte below (8 bits) is divided into two, 4-bit nibbles. An ASCII equivalent byte is then sent for each nibble.

3.20.33 Command Definitions

The following definitions apply to NPC-800C commands you can execute from an external controller. The controller can be another NPC-800C or a dedicated GPIB CONTROLLER. If the controller is another NPC-800C, the TRANSMIT field of the controller's I/O menu must be ON to avoid local response to commands (see Table 3-8 for command formats).

0 - Initialize All of NPC-800C

This command performs the same function as a power-up reset. All analysis parameters and data are reset, CP/M operating system is reset, and GPIB bus is also reset (Interface Clear is set).

1 - Initialize Analyzer

This command performs the same functions as the 0 command, except for the CP/M operating system and the GPIB bus. Thus, this command can be sent to the internal analyzer from a CP/M program to initialize only the analyzer and leave the rest of the system intact.

2 - Lock Keyboard

This command sets a flag which prevents access, through the keyboard, to the NPC-800C (by unauthorized users).

NOTE

The slave NPC-800 keyboard cannot be locked while in I/O menu on master. The user can only execute this function from CP/M or while in the analyzer (menu's or data display).

3 - Unlock Keyboard

This command resets Lock Keyboard flag and restores keyboard access.

4 - Clear CRT

This command causes NPC-800C to blank its CRT. Normally used with the Y command, it sends messages to an operator when the NPC-800C is under automatic control.

5 - CONFIGURATION LIST

This command provides a convenient method of calling the NPC-800C's Configuration List.

6 - CONFIGURATION LIST-SELECT 48 CHANNEL STATE

This command calls the Configuration List and sets cursor at 48 CHANNEL STATE mode.

7 - DUMPS CT/SA VALUE

8 - NOT USED

9 - COLLECT

This command has the same function as COLLECT key, but can be executed from any menu.

A - READ STATE SETUP

This command is used to read data into state menu.

B,C - READ STATE DATA

These commands are used to read data into State Aux Memory.

D - READ TIMING SETUP

This command is used to read data into timing menu.

E,F - READ TIMING DATA

These commands are used to read data into Timing Aux Memory.

G - DUMP STATE SETUP

This command is used to dump State Analyzer's setup.

H - DUMP MAIN STATE DATA

This command is used to dump State Analyzer's Main Memory Data.

I - DUMP AUX STATE DATA

This command is used to dump State Analyzer's Aux Memory Data.

J - DUMP TIMING SETUP

This command is used to dump Timing Analyzer's setup.

K - DUMP MAIN TIMING DATA

This command is used to dump Timing Analyzer's Main Memory Data.

L - DUMP AUX TIMING DATA

This command is used to dump Timing Analyzer's Aux Memory Data.

M - DUMP COLLECTION STATUS

This command is used to dump the Analyzer's Collection Status. If not collecting, then dump one byte for state analyzer and one byte for timing analyzer.

N - DUMP SIGNATURES

Dump Signatures (20 bytes): A,B,C, Main State Memory; A,B, Main Timing Memory; A,B,C, Aux State Memory; and A,B, Aux Timing Memory Signatures.

Q - NOT USED

This command is not used.

P - DUMP COLLECTION VARIABLES (16 bytes)

This command provides a State Word Count (4 bytes) and a Trigger Displacement (4 bytes); a Timing Word Count (4 bytes) and a Trigger Displacement (4 bytes).

QXXXXYYYY - DUMP STATE A PROBE DATA

This command is used to dump State A Probe data with most significant bytes followed by least significant bytes, where XXXX = start of dump displacement from first word collected and YYYY = word count to dump.

RXXXXYYYY - DUMP STATE B PROBE DATA

See Q command above.

SXXXXYYYY - DUMP STATE C PROBE DATA

See Q command above.

TXXXXYYYY - DUMP TIMING A & B PROBE DATA

This command dumps A Timing Probe data bytes followed by B Timing Probe data bytes (see Q command above).

U - DUMP SCREEN TO RS-232 DEVICE

Vaaaa - SINGLE BYTE MEMORY DUMP

This command is used to dump byte at HEX address to enabled output ports.

Waaaabb - SINGLE BYTE MEMORY WRITE

This command writes byte bb to address aaaa.

3.20.34 More I/O Examples

To further illustrate the GPIB CONTROLLER/DEVICE and RS-232 MASTER/SLAVE capabilities, your NPC-800C's diskette contains two CBASIC programs. These programs are called GPIBEX and RS232EX; they do not require any programming to use. Through easy-to-use menus, you can control another instrument and transfer data.

3.20.35 Source

Source listings for both programs are available on the diskette. Just type: TYPE GPIBEX.BAS or TYPE RS232EX.BAS. These listings will be of interest to those who want to modify such programs for their own application (type CNTL S to stop screen from scrolling; type any key to start).

3.20.36 RS232EX

The RS232EX program demonstrates the use of the NPC-800C's MASTER/SLAVE

capability. For this program two NPC-800's, tied together via the RS-232C interface, are required.

3.20.37 Procedure Setup

1. Define one NPC-800C as a MASTER and the other as SLAVE so that upon power-on reset, the master defaults to "MASTER" and the slave to "SLAVE" (see Section 3.20.12). Connect an RS-232 male-to-male cable between units.

PINS 2 & 3

BE SURE PINS 2 AND 3 ARE SWAPPED ON ONE END (use a break-out box or equivalent).

CRUN2 RS232EX OR CRUN23 RS232EX

2. Press RESET and type 1 for both units. On unit defined as a SLAVE, make sure that GPIB INTERFACE field is DISABLED; RS-232 MODE field is set to SLAVE. On unit defined as a MASTER, set up I/O CONFIGURATION MENU the same as for SLAVE, except be sure RS-232 MODE field is set to MASTER. On both units call the CONFIGURATION LIST. Then, for the MASTER, press ESC and type CRUN2 RS232EX.
3. On all test cards, connect each NPC-800C's A state probe to the A input connector. Be sure both probes are set to TRUE and TTL.

COMPARE UUT

4. When MAIN MENU appears, select option 1, COMPARE UUT DATA WITH "GOLDEN UNIT," and when LOGIC ANALYZER SETUP MENU appears, select: SETUP DATA WITH SIMPLE TRIGGER. At this point, follow directions to execute a pre-stored test in both units simultaneously. * The program concludes by comparing test codes to see if data collections match.

Other Logic Analyzer Setups

5. After program displays test codes, return to MAIN MENU; again select Option 1. Then experiment with other logic analyzer setups (go back to Step 2 to set up I/O CONFIGURATION MENU as before). Option 2 is similar to Option 1 except a more complex, multi-level trigger test is executed; Option 3 allows you to recall your own, previously saved file (using LASAVE). Option 4 allows you to use a manually set-up test.

* Messages TRANSMITTING and RECEIVING appear at appropriate points in each test step. It takes several seconds to several minutes, depending on the amount of data and data rate used, to complete data transfer between units.

Additional RS-232 Tests

6. Other RS232EX options are: VIEW/MODIFY LOGIC ANALYZER SETUP, which allows you to manually edit or revise MASTER's test setup;** SAVE CURRENT SETUP & DATA, allows you to store revised test on diskette for execution by Option 1 (COMPARE UUT DATA WITH 'GOLDEN UUT'). The last option, Option 4, allows you to exit.

** After editing logic analyzer menus, call CONFIGURATION LIST and type R to return to automatic control.

Section 4 Service

4.1 INTRODUCTION

This section provides basic servicing information that will help confirm if an equipment problem really does exist and if it is possible to isolate it to a specific assembly. And, to prevent equipment failures, it also provides recommended routine maintenance information.

In-depth troubleshooting information is not provided. Being beyond the scope of this manual, that level of repair should be performed only by trained personnel. The Maintenance Manual contains schematic diagrams, theory of operation, required equipment lists, and parts lists.

NOTE

If Your NPC-800C Was Damaged During Shipment, Refer to Section 4.4.

4.1.1 Air Filter Maintenance

To assure proper internal cooling of your NPC-800C, periodically clean the air filter. Frequency depends on the operating environment; however filters should be cleaned at least once every six months.

Filter is located on analyzer's upper-rear corner. It is held in place by three brackets attached with phillips head screws. To remove filter, loosen and remove knurled thumbnut which holds bottom bracket in place. Remove bracket from threaded stud. To remove, slide filter down and out.

Clean filter with soap and water, a mild solvent, or with air. Dry filter and depress inner surface gently so that filter material bulges outward, away from seam in filter's frame. Replace filter in two upper brackets, making certain that seam in frame is facing outward. Replace lower bracket and tighten thumbnut "finger-tight."

4.2 PERFORMANCE VERIFICATION TESTS

The tests described below simply confirm that the basic system is functioning, they will not identify the location of a problem. If these tests are not executed successfully, contact the nearest Nicolet Paratronics service facility. If these tests do execute properly, go to appropriate subsection of Section 3 and perform examples described there, using the demonstration circuit board supplied with your NPC-800C. Those procedures will confirm whether the feature with which you are having difficulty is performing properly.

If you cannot execute the procedures in Section 3 properly, contact the nearest Nicolet Paratronics service facility.

4.2.1 Initialization

When the NPC-800C is first switched on, a processor test series can be performed that checks the RAM, ROM, and other subsystems. As indicated at the bottom of the CONFIGURATION LIST, pressing BREAK key activates PROCESSOR SELF-TEST.

```

NORMAL HALFLIGHT BLINK REVERSE OVERLINE XXXXXXXXXX

RAM TEST: PASS
CHECKSUM VER 1      9BB9 E1DB F02E BC1E DB06 CC9C      CA91
ROM CHECKSUM TEST: 9BB9 E1DB F02E BC1E DB06 CC9C      CA91
8155 TIMER TEST: PASS
RS-232 TEST: FAIL      SHORT PIN 2 TO 3 ON RS-232 CONNECTOR
                   FAIL      SHORT PIN 4 TO 8 ON RS-232 CONNECTOR
                   FAIL      SHORT PIN 5, 6 AND 20 ON RS-232 CONNECTOR
VERTICAL SYNC TEST: PASS

■ ■ MODEL 8000 PROCESSOR BOARD FUNCTIONAL TEST

```

Figure 4-1. Processor Self-Test

4.2.2 Basic State Analyzer Collection

1. Insert a Model 51A State Probe into A (STATE) input on left side of NPC-800C. Make sure plastic key on probe connector is facing up.
2. Plug probe head into A side of Logic Analyzer Test Card. Be sure probe switches are set to TTL and TRUE.
3. Turn power on using power switch in right rear side of NPC-800C. * If unit is cold, wait up to 30 seconds for CONFIGURATION LIST to appear. The half-intensity cursor should be located at top of list.

* The NPC-800C emits a short beep upon power up or the pressing of the RESET key. This beep signifies that the NPC-800C has been reset.

- Press F6 key, labeled COLLECT on CRT, to take an arbitrary state data collection. The resulting display should contain twenty hexadecimal words whose four most significant digits contain values somewhere between 0000 and 00FF. The rest of the digits should be all F's (see Figure 4-2). See Section 3 for additional state data collection examples.

MAIN	TRIG	0032	FFFFFFFF
	+001	0033	FFFFFFFF
LOC: TRIG	+002	0034	FFFFFFFF
	+003	0035	FFFFFFFF
SIG: C137	+004	0036	FFFFFFFF
0803	+005	0037	FFFFFFFF
0803	+006	0038	FFFFFFFF
	+007	0039	FFFFFFFF
	+008	003A	FFFFFFFF
	+009	003B	FFFFFFFF
	+010	003C	FFFFFFFF
	+011	003D	FFFFFFFF
	+012	003E	FFFFFFFF
	+013	003F	FFFFFFFF
	+014	0040	FFFFFFFF
	+015	0041	FFFFFFFF
	+016	0042	FFFFFFFF
	+017	0043	FFFFFFFF
	+018	0044	FFFFFFFF
	+019	0045	FFFFFFFF
	+020	0046	FFFFFFFF
	+021	0047	FFFFFFFF
	+022	0048	FFFFFFFF
	+023	0049	FFFFFFFF

Figure 4-2. Arbitrary State Data Collection For NPC-800C

4.2.3 Basic Timing Data Collection

- To reinitialize NPC-800C, press RESET for approximately two seconds.
- Insert a Model 81A Timing Probe into A (TIMING) input on left side of NPC-800C. Be sure plastic key on probe is facing up (you can leave state probe connected to analyzer).
- Plug probe head into B side of Logic Analyzer's Test Card (there are no switch settings on this probe).
- Turn power on. After CONFIGURATION LIST appears, move cursor down to 16-CHANNEL TIMING mode by pressing F4 key labeled SEL DOWN.
- To take an arbitrary timing data collection, press F6, soft-key labeled COLLECT. This collection should contain sixteen high or low logic levels (see Figure 4-3). The 100 nanosecond sampling rate of the NPC-800C at power on is much faster than

the clock rate of the CMOS test card. Therefore, few, if any, logic transitions will be captured (see Section 3 for additional timing collection examples).

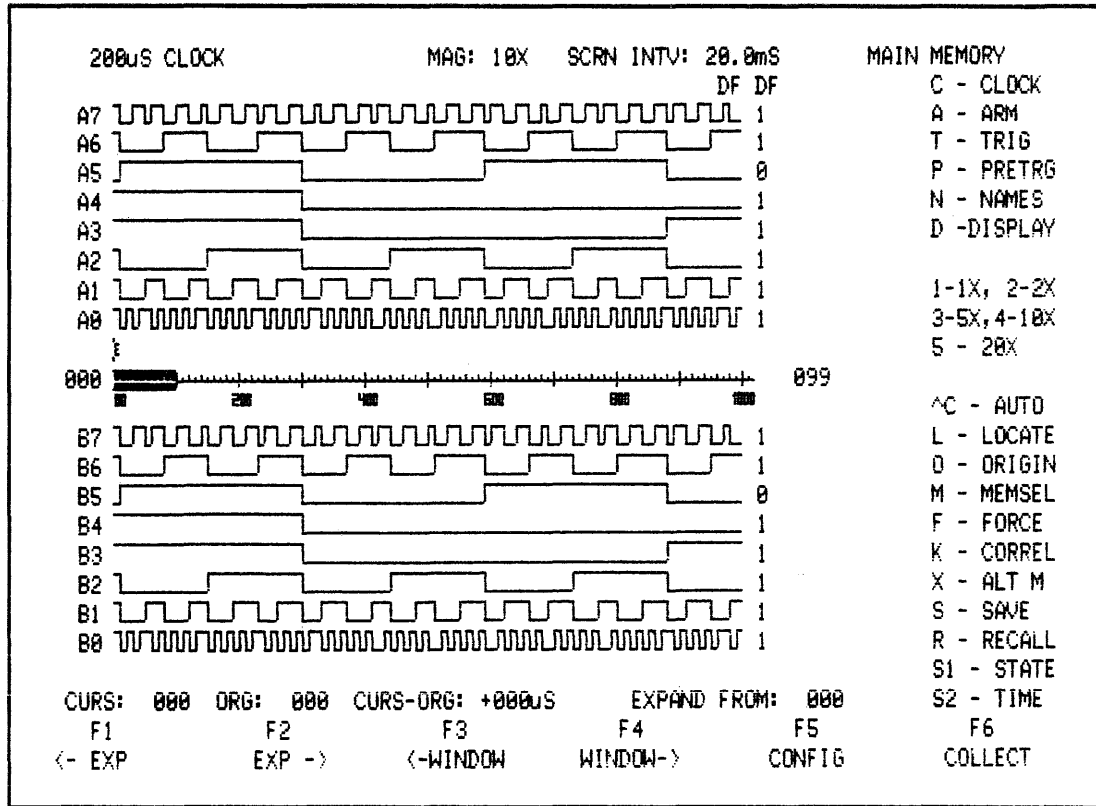

Figure 4-3. Arbitrary Timing Data Collection
(Your data are probably different)

4.2.4 Basic Waveform Collection (Option Must Be Installed)

1. Press F5, the soft-key labeled CONFIG. CONFIGURATION LIST should appear.
2. Using F4, the SEL DOWN key, step cursor down to Waveform mode.
3. Press COLLECT key. Since Model 90 (10X/1X) scope probe is not connected and there is no input signal, the waveform display contains only a baseline (see Figure 4-4) (If Waveform option is not installed, display will not contain baseline). See Section 3 for additional waveform collection examples.

4.2.5 Counter/Timer Collection

Repeat Steps 1 and 2 above except step to COUNTER/TIMER mode. Press F1 key. Since no input signal is present, readout inside display window should be all zeroes (if this option is not installed, display window is blank). See Section 3 for additional examples.

4.2.6 Signature Analyzer Collection

Repeat steps 1 and 2 above except step down to Signature Analyzer mode. Since no input or gating signals are present, no meaningful display is present (this test verifies presence of menu only). See Section 3 for additional examples.

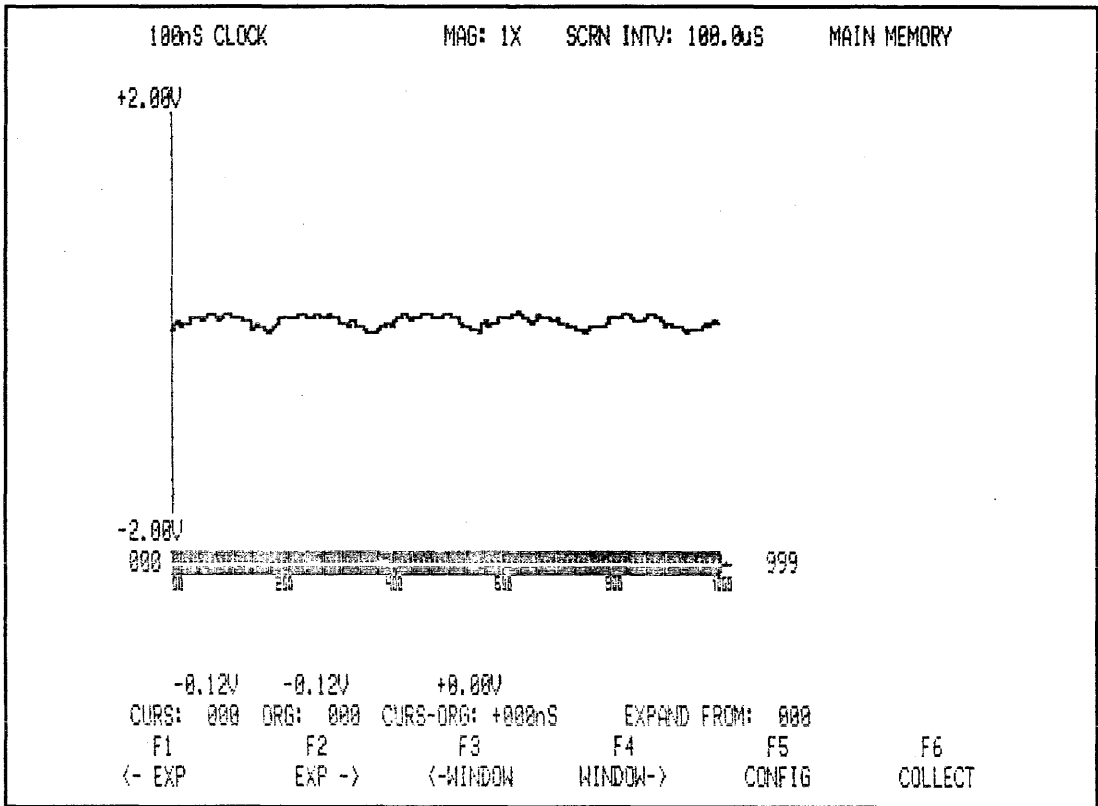

Figure 4-4. Waveform Display Without Input Signal

4.2.7 Disk Subsystem (NPC-800C)

When not in use, diskette should be kept inside its protective paper envelope. Recording medium on the diskette is protected within a sealed plastic jacket. **DO NOT ATTEMPT TO REMOVE THE PLASTIC JACKET.**

To insert diskette into disk drive, remove diskette from paper envelope. Notice the large, circular opening in the center of the diskette, the long oval READ/WRITE head opening, and a square WRITE PROTECT notch along one edge of diskette.

4.2.8 Diskette Insertion

To insert diskette, orient plastic jacket so that WRITE PROTECT notch is at the bottom and the label faces towards the CRT (see Figure 4-5).

Carefully slide diskette into vertical opening on drive until no additional movement in direction of insertion is possible. Now mount diskette to drive by rotating door handle 90 degrees to the right until handle latches, firmly clamping diskette onto drive motor spindle.

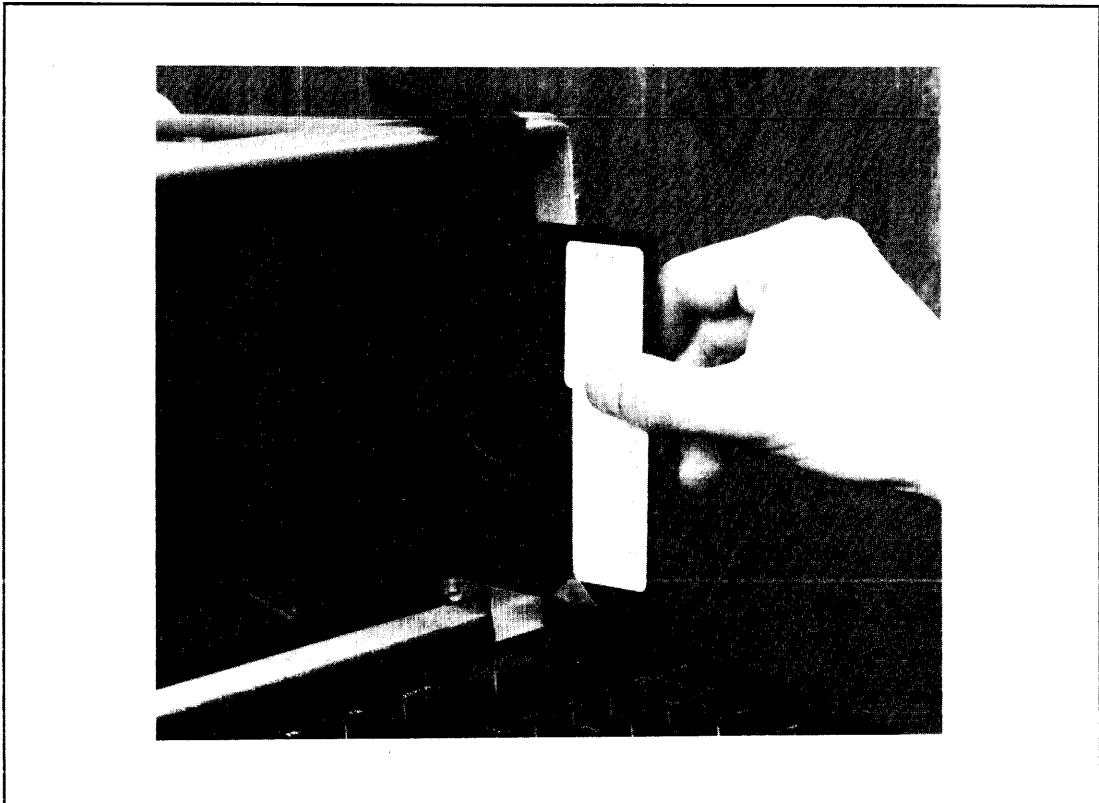

Figure 4-5. Loading Diskette

4.2.9 Diskette Removal

To remove diskette release latching mechanism. A partially ejected position is acceptable during power-up/down of the NPC- 800C.

WARNING

To protect data on the diskette, it is good practice NEVER to interrupt power to the NPC-800C when a diskette is fully mounted on the drive.

4.2.10 Adjustments

The disk drive motor is part of a servo-controlled loop. It is independent of changes in line voltage and line frequency; therefore, no speed adjustment is necessary.

4.2.11 Operational Check of Disk Subsystem

1. If power was off, turn power on and insert a CP/M diskette as described above; otherwise, call CONFIGURATION LIST by pressing F5 key.
2. When CONFIGURATION LIST is displayed, press ESC (escape) key to exit analysis mode and enter CP/M mode (red LED on disk drive will illuminate).
3. Wait until a sign-on (header) and the CP/M prompt: A > appears. Next type DIR (directory) and press RETURN to see programs resident on disk (see Section 3 for additional CP/M information and examples).

4.3 SELF-TEST PROCEDURES

4.3.1 Introduction

Included on the disk that you receive with your NPC-800C (if you have a nonvolatile memory option) are three programs which perform a hardware and software self-test. Although these tests are not exhaustive, they do provide the user with a measure of confidence that the NPC-800C is operating properly. These tests are KYBDTEST.COM, which tests the keyboard; DSK5TEST.COM, which tests disk drives and diskette; and RAMTEST.COM, which tests the 48k of dynamic RAM. The PROCESSOR SELF-TEST (which tests processor's STACK, RAM, ROM, character generator, RS-232C interface IC, and 8155 timer IC) is in analyzer ROM and can be accessed whenever CONFIGURATION LIST is displayed.

With this extensive set of self-test programs, the user should be able to confirm whether the microcomputer portion of the NPC-800C is functioning properly. The analyzer portion can be further tested using Section 3 of this manual. Results of those examples are predictable so the user should have no trouble confirming whether the analyzer is functioning properly.

To perform the disk-resident self-test functions, turn power on, load diskette onto drive, press ESC to exit to CP/M, press CAPS LOCK to its down position, and type test file name that you want to execute.

4.3.2 Keyboard Test

To test the keyboard, type:

KYBDTEST (RETURN)

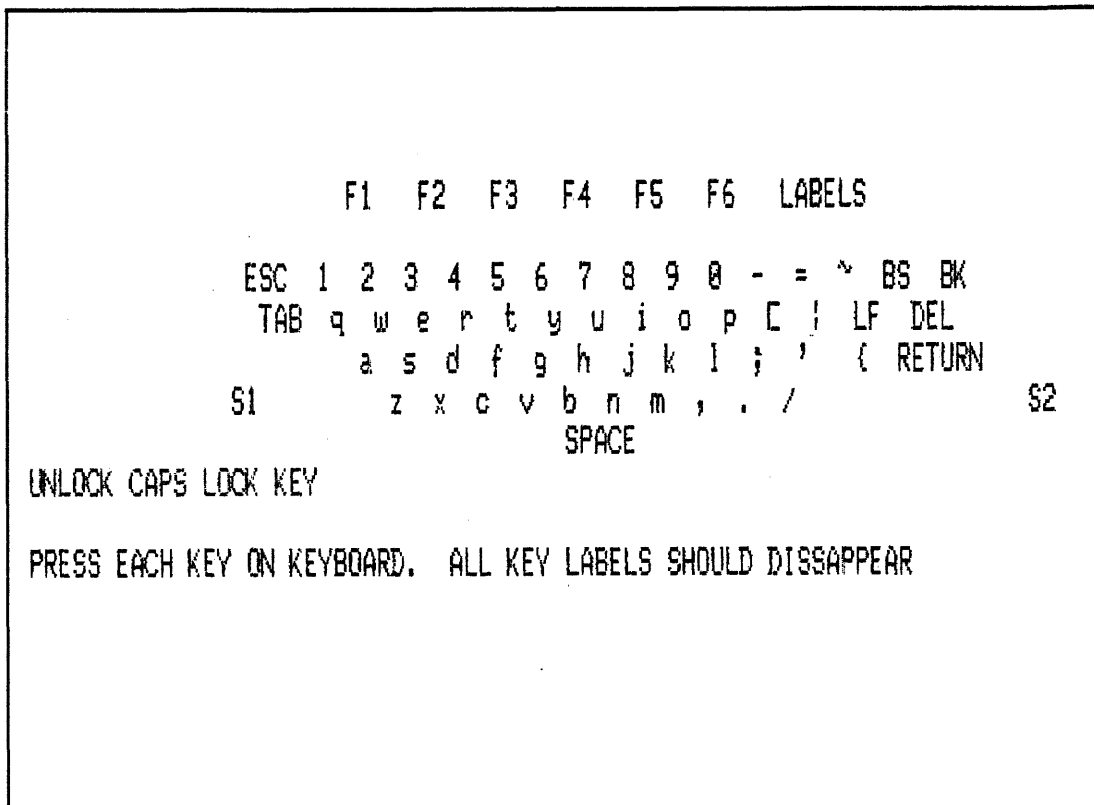

Figure 4-6. KYBDTEST

The program is loaded into RAM and begins executing. As shown in Figure 4-6, there should be a representation of the keyboard layout on the display. As you test each key, the associated key on the display disappears. Press each key in turn until all keys have been recognized and removed from the display. If you press a key which does not have a duplicate on the display, the program will allow you to stop the test or to continue (program does not know whether you pressed wrong key, or if keyboard is defective). As each key is pressed, the ASCII value (in HEX) of each key is displayed in upper left corner of CRT.

4.3.3 Disk Test

To perform disk test, type:

DSKSTEST (RETURN)

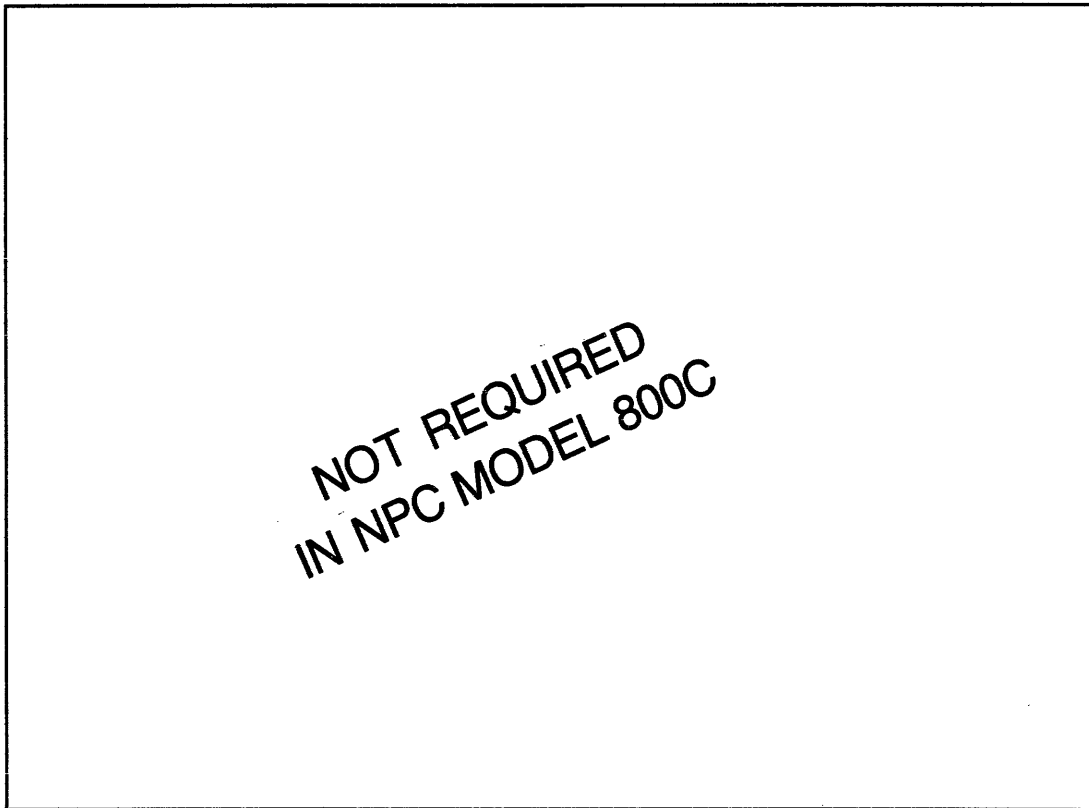

Figure 4-7. DSK5TEST

Answer each question asked by the program as shown in Figure 4-7. Unless you have more than one disk drive installed, your answer to the SELECT DRIVE statement will always be A. The number of retries to select (attempts to retest a specific block of the diskette upon encountering a failure) is determined by you. Normally, that number should be 0. The drive reads each track in sequence. However, if you answer "Y" to FULL TRACK SEEK, the drive steps back to track zero after reading each track and then proceeds to next track in the sequence. When test is complete, you have the option to repeat the test once, continuously, or not at all.

4.3.4 RAM Test

To perform a test of the dynamic RAM (not high speed analyzer RAM), type:

RAMTEST (RETURN)

```
| STATE AUX AND 48K DYNAMIC RAM TEST PROGRAM 01/30/84  
SET RAM TO HIGH(ADDR).EOR.LOW(ADDR)  
  
TESTING ADDRESS:      77B2  
LAST FAILED ADDRESS: ---- EXPECTED: -- READ: --  
TOTAL FAILURES:      0  
PASSES COMPLETED:  1
```

Figure 4-8. RAMTEST

The program performs a fast READ and WRITE, then begins a “walking ones and zeroes” test. This portion of the test is quite long, so you might not want to monitor this test, merely check the results (see Figure 4-8).

4.3.5 Processor Self-Test

To call CONFIGURATION LIST, press RESET. Press BREAK key to execute PROCESSOR SELF-TEST as shown in Figure 4-9.

```

NORMAL HALFLIGHT BL: K REVERSE OVERLINE
RAM TEST: PASS
CHECKSUM VER 1      9BB9 E1DB F02E BC1E DB06 CC9C      CA91
ROM CHECKSUM TEST: 9BB9 E1DB F02E BC1E DB06 CC9C      CA91
8155 TIMER TEST: PASS
RS-232 TEST: FAIL      SHORT PIN 2 TO 3 ON RS-232 CONNECTOR
                   FAIL      SHORT PIN 4 TO 8 ON RS-232 CONNECTOR
                   FAIL      SHORT PIN 5, 6 AND 20 ON RS-232 CONNECTOR
VERTICAL SYNC TEST: PASS

MODEL 800 PROCESSOR BOARD FUNCTIONAL TEST

```

Figure 4-9. Processor Self-Test

The program first prints both character sets located on top of display. It then prints each of the "attributes" used in the display: NORMAL video, HALFLIGHT video, BLINKING messages, full intensity REVERSE video, OVERLINE, and HALFLIGHT REVERSE video. Next it performs a test of the stack RAM and checksum of each ROM. The first row of checksums is the reference data stored in ROM. The second row is the result of the current checksum calculation. Finally, the 8155 timer IC and the RS-232C* interface IC are tested. This test is repeated continuously, so press RESET to exit from this program.

4.4 RETURNED MATERIAL AUTHORIZATION

4.4.1 Return of Equipment

If your unit must be sent back to the factory or an authorized service center for any reason, contact Nicolet Paratronics or your local sales office for instructions and a RETURN AUTHORIZATION NUMBER.

NOTE

EQUIPMENT RETURNED TO THE FACTORY OR SERVICE CENTER WITHOUT PRIOR AUTHORIZATION WILL ONLY DELAY THE REPAIR PROCESS. BY FIRST CONTACTING NICOLET PARATRONICS, WE MIGHT BE ABLE TO SOLVE YOUR PROBLEM AND SAVE YOU A LOT OF TROUBLE.

* For RS-232C test to pass, you must connect the TRANSMIT pin (3) to the RECEIVE pin (2).

4.4.2 Suggestions Concerning Return of Equipment

If you have authorization to return equipment, use original shipping container and packing material, if possible. Also, it is always a good idea to insure any equipment shipped.

If subassembly, board, PROM, diskette, or other component responsible for the problem can be identified (with or without the help of our application engineers), it is often more convenient, and certainly less costly, to return just the faulty item rather than entire instrument.

IMPORTANT NOTE

U.S. CUSTOMERS SHOULD CONTACT OUR CUSTOMER SERVICE DEPARTMENT FOR ASSISTANCE AT THESE PHONE NUMBERS

- (800) NICOLET (Toll-Free outside California)
(415) 490-8300 (California)**
- OUR CUSTOMER SERVICE ENGINEERS CAN ANSWER QUESTIONS AND AUTHORIZE RETURN OF EQUIPMENT.**
- INTERNATIONAL CUSTOMERS SHOULD DEAL DIRECTLY WITH THEIR LOCAL NICOLET PARATRONICS' SALES AND SERVICE CENTER.**

No matter the procedure, please send a description of the problem along with the faulty item. If you return the entire instrument, INCLUDE ALL PROBES AND ACCESSORIES. Refer to Section 2 for more information.

Section 5

Option Installation

5.1 INTRODUCTION

To enhance the capabilities of your NPC-800C, you have several options from which to choose. Some of those options may be installed in the field, and some require that the instrument be returned to the factory or to an authorized service facility for installation.

The table below summarizes which options are internal to the logic analyzer, which are external, and whether they can be installed by the user. Those that permit field installation are easy to install and can be installed using ordinary hand tools.

Option Description	Internal/ External	Field/ Factory
Nonvolatile Memory	Internal	Factory
Waveform Recorder	Internal	Field
Counter-Timer	Internal	Field
Second Disk Drive	Internal	Field
Performance Analysis	Internal	Field
Printer Software	Internal	Field
Computer/Controller	Internal	Field
Printer	External	Field
Dedicated Probes	External *	Field
In-Circuit Emulators	External	Field
Upgrade of Basic Analyzer	Internal	Factory

* Each dedicated probe consists of a special microprocessor hardware interface and software or firmware to display collected information in an easy-to-read format. For those NPC-800Cs with the Nonvolatile Memory option, that software resides on a diskette and requires no internal installation. However, for those NPC-800Cs that do not have the Nonvolatile Memory option, that software resides on an EPROM, and requires that you install that EPROM on one of the circuit boards inside the NPC-800C.

Section 6

Glossary

Acquisition The process by which input logic signals are compared at a discrete instant to a threshold level and recorded.

Active Clock Edge The clock transition on which all receivers (listeners) interpret the data on the bus. A logic analyzer must monitor the system using this same active edge as its clock.

Address Bus That bus in the system used to address or define the memory or device location enabled.

Aliasing The misleading display of a sampled analog waveform when the sample rate is less than twice the input frequency.

Arm An input or condition that must occur prior to the analyzer trigger conditions being recognized. See Trigger Enable.

ASCII American Standard Code for Information Interchange; a standard alphanumeric code defining a character set.

Assemble To combine routines to form a program; to translate a source program into a machine language, usually producing one machine language instruction for each source language instruction.

Assembly Language A language of mnemonics (resembling English more closely than 1's and 0's) that defines the machine instruction to be executed.

Asynchronous Clocking Data is clocked into the logic analyzer at a rate unrelated to the system under test. See Timing Analyzer, Synchronous Data.

Asynchronous Data Data that is not referenced to time. The completion of one operation signals the next operation.

Asynchronous Triggering Triggering of timing analyzer by signals independent of the analyzer clock.

Automatic Test A capability of some analyzers that allows the storage of a partial or complete test procedure, plus the expected results, in an auxiliary memory. Tests are then executed with minimal user intervention.

Auxiliary Memory Space in memory in addition to the active recording memory. It may include RAM and PROM and is used in comparing data, halting on difference, automatic testing and other functions.

Baud Rate The number of symbols per second that are transmitted (a symbol normally consists of one bit.)

Block Transfer The movement of a group of fields from one group of addresses to another group of addresses.

Bootstrap The instructions at the beginning of a program together with a few instructions entered from the control console used to load a program into RAM; a minimal-size loader program.

Branch See Transfer Command.

Breakpoint A point in a program in which a process(or) may be made to stop automatically for a check on the progress of the data handling. See Emulator.

Bus System A network of paths or set of lines that facilitate data flow in a digital system. The common buses are the address, data, and control buses.

Call To place the necessary initial values of variables in the required addresses and then to transfer control to a subroutine. See Transfer Command.

Clock The pulses that control the timing of operations in a digital system; some systems having more than one clock. Both the system and any monitoring instrument must interpret the data on an active clock edge when all data are valid.

Clock Delay The number of occurrences of a clock before an event.

Clock Qualifier Additional logic analyzer inputs that may or may not be displayed that define conditions as to when data may be sampled or displayed. A sample is taken only on an active clock edge provided the clock qualifier conditions are satisfied. See Active Clock Edge, Sampling.

Clock Slope The transition or active edge at which the analyzer samples data. See Edge Sensitive.

Combinational Trigger The pattern of 0's, 1's, and "don't cares" set on all channels that, when matched by the sampled data, causes a trace to commence.

Comparator A circuit that compares two or more signals and supplies an indication of their agreement or disagreement to initiate some other action.

Compare Data Any form of display in which a captured data record is manipulated with the data set in an auxiliary memory in such a way as to make differences conspicuous. Two examples: the "exclusive-OR" display and rapid alternation of the display between recording and auxiliary memories.

Compiler A routine by which a computer can translate a source program into an object program by assembling and copying from other programs stored in a library of routines.

Composite Video An analog signal containing not only display information but also horizontal and vertical synchronizing pulses, all of standard polarity and size.

Concatenate To connect or link elements in a series or chain to form a whole.

Conditional Transfer An instruction that causes the processor either to continue with the next instruction in the original sequence or to change control to some other designated instruction, depending upon the result of some logic operation. See Transfer Command.

Contents The word or field stored at a given address or in a given register.

Control Character A character embedded in operand data that specifies an operation to be done, such as skip to a new page while printing output data.

Correlation A comparison function; a figure of merit, indicating the number of similarities relative to the number of differences between two elements.

CR Carriage Return; a control character used to end an input from a keyboard; refers to the mechanical carriage on a printer returning to begin another line, requiring a finite amount of time.

Cross Compiler A special utility program allowing compiling of code for a processor which differs from the host.

Cross-Domain Linkage Linkage between the state, timing, and analog domains. See State Analyzer, Timing Analyzer.

CT/SA Counter-timer/signature analyzer. See Time Measurements.

Data Compression Any display technique intended to reduce the time or effort required to examine an entire data record. The simplest form converts binary words into hexadecimal words. One of the more effective techniques is signature analysis. See Signature Analysis.

Data Domain A domain concerned with the total amount of data that must be collected at every event/time in order to characterize synchronous system behavior. A logic analyzer is a data domain monitoring instrument.

Data Qualified Clocking Specifying a data pattern that is logically ANDed with the clock, to exclude "non-qualified" clock occurrences.

Data Rate The clock rate for synchronous systems; it must not exceed the specified maximum clock rate of the analyzer.

Debugger A program used to facilitate testing of a microprocessor system.

Decision In computer operations, the processes of detecting the existence of specified patterns of relationships in the data being handled, and of taking alternative courses of action based upon the differences detected. See Transfer Command.

Dedicated Probe (Personality Probe) A probe used to examine a particular microprocessor chip used by clipping over the processor and passively monitoring its state transaction.

Delay User set for an N-count of selected events. Delay is used to offset in time the position of the final data record with respect to the triggering event. See Clock Delay, Trigger Delay.

Demultiplexing (Demux) The sorting of multiple signals which time-share a signal path into dedicated lines (channels).

Density Referring to a memory diskette, how closely information is packed on a track.

Diagnostic Routine A routine designed to locate either a malfunction in a computer system or a mistake in coding.

Disassembly The reverse of assembly; to convert machine language code into user recognizable mnemonics, usually done with the help of a dedicated personality probe. See Assembly Language, Dedicated Probe.

Diskette A flexible mylar oxide-coated storage device, commonly known as a floppy.

Display Polarity If a logic one at the probe input is displayed as a logic zero on the CRT, the display polarity is said to be inverted (-). If a 1 at the probe inputs is displayed as such, the polarity is normal (+).

DMA Direct Memory Access is the transfer of I/O information to memory by bypassing the processor.

Don't Care A channel that may be in either state "0" or state "1," symbolized "X," thereby not restricting data qualification if used in a qualifier word.

Don't Care Triggering A triggering condition where all of the trigger bits are don't care. The first data that comes along will be traced.

Edge Sensitive Response of a system to rising (positive) or falling (negative) or trailing transitions as opposed to levels of the clock. See Active Clock Edge.

Edit To arrange, rearrange, or arbitrarily alter information, especially in format.

Emulator Hardware containing a microprocessor that replaces the target system's microprocessor and permits execution and interaction with the user's program.

External Trigger An active signal or an external logic analyzer input that will start (trigger) the analyzer. See Trigger.

Field (in a menu) One or more adjoining characters treated as a group.

File A set of records on a common subject and usually organized or ordered on the basis of some combination of items of data uniformly found in all the records of the file, such as a date.

Filter A circuit that ensures trigger conditions (i.e., Boolean combinations) are satisfied for a minimum time before actually triggering the analyzer.

Flow Chart (diagram) An analysis technique providing a graphic presentation of a procedure. In programming, a chart setting forth the particular sequences of operations to be done in a computer to handle a particular application.

Format An arrangement of information on a form, document, or in storage. Configuration of a logic analyzer, e.g., arbitrary labels given to input channels, clock and logic polarities, and display presentation.

Glitch Memory An auxiliary memory that stores the presence of any glitches between sample periods.

Glitch Triggering Triggering on a glitch on any specified channel. Usually combined with other logic level requirements on all lines.

Halt on Difference The trigger caused by any detected difference, when incoming data is continually compared to the contents of an auxiliary memory. See Hold \neq .

Hold \neq A trigger mode that causes a logic state analyzer to continually collect data until a difference is detected between main and auxiliary reference memories. The last collection is held for display with differences intensified.

Hold-Time The time following the active clock edge where the analyzer may sample data. Since many systems do not hold the data past the active clock edge, a logic analyzer should have a zero hold time ideally.

Housekeeping Computer operations which do not directly contribute to useful data handling—extracting of fields, verifying the identification of the input, etc.; in general, the setup (including initialization) and cleanup operations in a program.

In Circuit Emulation See Emulator.

Independent CLK/TRIG Qualification The concept of forced acceptance of an otherwise not qualified trigger word; occurring before or after (i.e., displaced from) the clock qualification. See Clock Qualifier, Trigger Qualifier.

Initialization When first powered up, a processor will have a random program counter value so that setting variables and control indicators in a program to their starting values is necessary.

Instruction A word or field that directs the automatic computer to take a certain action. The instruction usually consists of a command together with one or more operand addresses, which, taken together, cause the computer to act upon the indicated operands.

Intelligent Controller Referring to GPIB instruments it is the director of any transactions on the bus equipped with a uP.

Interpretive Routine An executive routine which, during the course of data-handling operations, translates a stored macrocoded program into a machine code and at once performs the indicated operations by means of subroutines.

Interrupt An external control system used to suspend normal operations and possibly cause new sequences of instructions to be followed.

Inverse Video A black on white display used to highlight trigger words; or in serial displays, the data received. In formatting an analyzer, it is used to indicate user-definable parameters.

Iterative Loop A repeated group of instructions in a routine.

Jump See Transfer Command.

Label An identifier, in either human or machine language, e.g., a magnetic tape label identifying the tape or an address identifying a storage location, or an alphanumeric character representing an input channel.

Latch A glitch latch detects narrow pulses and stretches them such that they are traced by the clock.

LF Line Feed. See Carriage Return.

Library Routines A collection of standard and fully debugged programs, routines, and subroutines by means of which many types of problems and parts of problems can be processed or handled.

List A string with pointers (called links) added to each data element to enable their logical sequence to be different from their physical sequence.

Listener A device in a digital system that is reading data from the bus.

Load Routine A routine which causes a computer to transfer object code into RAM storage. See Bootstrap.

Lockout The recognition by the processor of an illegal or impossible triggering requirement. Simplification of the restraining conditions is recommended.

Lookup Table A memory structure, typically a ROM, where a specific address yields specific yet repetitive data. The process of finding a function in a table when provided with a key and arguments.

Loop An iterative routine, usually subject to instruction modification in a progressive manner until an exit condition is reached.

Machine Language Information represented in a form which an automatic computer can handle directly. For example, the result of assembling a symbolic source program is the machine language object code.

Macro, Macrocommand, Macroinstruction A symbolic command or instruction that is translated into two or more machine language instructions (often an entire subroutine) by the translator program.

MDS Microprocessor Development System; a system of hardware and software used to develop and help debug microprocessor-based products. See Emulator, State Analyzer, Timing Analyzer.

Microprocessor Analyzer A special logic state analyzer that monitors microprocessor bus systems and displays the results in microprocessor mnemonics. See Dedicated Probe.

Microprogram A basic command repertoire for an automatic computer that consists only of basic elemental operations which the programmer can combine into commands to suit his/her own convenience and in terms of which he/she would then program.

Mnemonic A set of symbols that combine a series of 0's and 1's, as used by a machine, into symbols that suggest the instruction to a human (for example, LDA is Load Accumulator).

Monitor To execute a program under the control of an executive routine; an executive routine capable of controlling the execution of a number of different programs one immediately after the other, including the clean up and restart between each program, thus relieving the operating personnel of some control functions and reducing computer idle time. See Operating System.

Multiphase Clocking Input data is organized as multiple words in width, each word with its own clock input. User may select positive or negative-going edges for each clock — a necessary capability when the analyzer is used with a microprocessor that multiplexes data and address information on the same bus (for example, the Intel 8085).

Multiple Occurrences Part of the trigger conditions that require the analyzer to find the trigger state a specified number of times in order to completely satisfy the trigger conditions. See Clock Delay, Trigger Delay.

Multiplexed The process of transmitting more than one set of signals over one bus; e.g., address and data information could occur at different times on the one bus. Information on the bus is defined by the control signals.

Negative Logic Refers to a logic “0” being true; a common misconception is that it refers to negative voltage levels.

Negative Time Events that occur before the defined trigger conditions are satisfied are said to occur in negative time. See Pretrigger.

Nested Loop A subroutine enclosed within a larger subroutine.

Nibble Half of a byte.

Non-occurrence Trigger In the sequential triggering mode, means trigger, if any word other than B occurs N events after A. It can have meaning for parallel triggering, if the inputs are organized as two words. Then the term means trigger if one word and anything but the other word occur simultaneously. See NOT Trigger.

NOP An instruction causing no change in the processor except a normal increment of the program counter, in other words, to go to the next instruction.

NOT Trigger A trigger condition that initiates data acquisition any time a state other than the state specified occurs. Also known as non-occurrence triggering.

Object Program A program produced by some translation process, as by the use of a compiler routine, from a source program. An object program need not be in a machine language, but often is.

Op Code The portion of a software instruction set that defines the next operation to be performed. Often extra information (the operand) will be required to define the data or location on which the op code will operate. See Dedicated Probe, Mnemonic.

Operand The part of an instruction to a processor that defines the data or the location to which the op code refers; something acted upon.

Operating System An executive routine and other supporting programs used to assist and control, in part, the operation of a computer. See Monitor.

Parallel Trigger The event caused by the occurrence of a selected word (or simultaneous occurrence of two words, like address and data) at the inputs. One of the obvious advantages of logic analyzers over conventional analog oscilloscopes.

Parity Check A type of redundant check in which the evenness or oddness of the number of 1 bits is verified.

Pass Count See Clock Delay, Trigger Delay.

Patch A correction made to a program and usually inserted into the control sequence by unconditional transfers of control.

Pointer A means of designating the address or name of something. See Label.

Positive True Logic Refers to a logic "1" being true.

Polling A technique in which multiple I/O devices time-share an I/O channel without contention.

Post Processing Processing of data after the collection is complete. For example, determining the number of occurrences of a specific data pattern.

Post-trigger Positive Triggering. Post-trigger means the captured record consists of data, all or most of which occurred after the trigger.

Pretrigger Negative Triggering. Pretrigger means that the captured record consists of data, all or part of which occurred before the trigger. It can never be greater than the memory capacity.

Probe The pod on the logic analyzer that actually connects to the circuit under test. Important criteria are probe loading and speed capability. The mechanical interface to the system under test. A basic probe consists of a ribbon cable terminating in a pod with flying leads. The pod contains input buffers and sometimes other circuitry, which can, for example, set the logic threshold.

Program A set of in-sequence, coded instructions for a digital computer, sometimes known as a routine or a subroutine.

Program Counter An essential register in a CPU keeping track of where a program is.

Protocol The sequence of events or the format of signals or lines that must occur for the correct operation of a system.

Qualifier An additional input, not necessarily recorded as data, but used to enable the trigger or the analyzer's clock input.

Radix (base) The fundamental number of a number system, e.g., 10 in the decimal system.

Restart Used with sequential trigger to restart the trigger sequence should a given state occur; useful when a critical branch is encountered in program flow.

Resolution The time interval over which a transition displayed by a timing analyzer may have occurred. For a single channel this will be 1 clock period. Between channels, the resolution should be ± 1 clock period.

Routine A program, or a part of a program.

Sample Window The sample window consists of set-up and hold times and is the time about the sample instant when the analyzer registers data.

Sampling Examining a voltage at discrete instances in time with the implied assumption that the waveform is constant until the next sample strobing.

Scroll The rolling or shifting of the logic analyzer display window through the analyzer memory.

Sector The subdivision of a track on a memory disk. On floppy diskettes two versions are available: hard and soft sectored.

Sector Access Hole A small hole on the floppy diskette jacket through which the index hole can be sensed by the disc drive timing sensor.

Selective Trace A data collection where the data sampled is selectively edited before being stored in memory; performed to conserve memory space.

Sequential Trigger A trigger condition that must be satisfied by a series of states in the specified sequence. The event caused when and only when data word B follows data word A by N selected events. N is usually set by the delay function.

Serial Data Bus A bus on which the data is all transferred bit- by-bit in a serial manner.

Set-Up Time The time prior to the active clock edge during which data may be sampled by the analyzer. Therefore, the data must be valid for at least this interval.

Signature Analysis A technique for data compression, in which the entire data record is compacted into one or more 4-character words through an algorithm that weights each bit equally. For all practical purposes, this signature is unique to the data and may be compared to a known, good signature.

Simulator A program used in a host computer to test the correctness of machine code. See Emulator.

Single Step To execute a program on a step-by-step basis.

Skew The difference in the delays across channels as measured between the probe tip and the point when the data is interpreted by the analyzer.

Soft-Key A key that serves different purposes at different times, as defined by software, and is labeled accordingly.

Source Program A program that is to be translated to an object program; for example, a program written in a symbolic language.

Stack A group of storage locations used to temporarily store data, in a modified sequence, according to the last location, unlike a program counter.

State Analyzer State-sequences of a digital system are recorded for analysis with a logic state analyzer.

Storage Dump A read-out or printout of the contents of a storage device. Usually only the contents of internal storage are dumped, and usually the read-out is onto magnetic tape or disks, and the printout onto paper via a line printer or typewriter.

Synchronous Analyzer Traces data which are synchronized with the clock of the system under observation. See State Analyzer.

Synchronous Data Data that coincides or is valid with a defined clock or control signal.

System Clock Clock signal provided by the system under test.

Table A listing. See State Analyzer.

Talker A device in the system that is putting data onto the IEEE-488 bus.

Text Editor A program used to develop and modify source programs, used before translation to an object program.

Threshold A signal amplitude level that divides one state from a second. A facility that allows the threshold on a logic analyzer to be varied either for different logic families or to check marginal data transitions.

Threshold Adjust An adjustment control on a logic analyzer used to vary the voltage level that defines what a logic analyzer will interpret as a logic "0" or logic "1." This can be software programmable or a hardware adjustment point. See Variable Threshold.

Threshold Range Spread of threshold voltage to accommodate different logic families.

Time Out If a trigger event does not occur within a preset time, a trigger event will be forced.

Time Measurements Time measurements with logic analyzers that may be relative (between samples), absolute (from trigger word), or between states and trigger stack levels, or between edges of specific traces.

Timing Analyzer A timing analyzer monitors the activity of a digital system and presents its observations as a state-time display or a pseudo-waveform of logic levels and transitions.

Trace Programming To follow the control sequence instruction-by-instruction, usually producing a printout reporting the consequences of each instruction; a routine for doing tracing. A hardware trace is the video display of a logic waveform.

Track The path on which data is recorded on a floppy diskette, lying directly beneath the read/write head.

Transfer Command A signal that conditionally or unconditionally specifies the location of the next instruction and directs the CPU to that instruction. See Conditional Transfer.

Transfer Rate The speed of data transmission, usually quoted in characters (baud) or bits per second.

Transient Triggering Triggering of a timing analyzer on a state that only occurs as a transient. See Hold ≠

Trigger A word, or sequence of words or events, that defines the point where a logic analyzer references its trace to the system activity, the start of a data collection process. To initiate the capture of a data record. Loosely, it may refer to the triggering event. See Parallel, Sequential, Non-occurrence, Pre and Post-trigger.

Trigger Delay Delay added so that the Nth word past the trigger is recorded by the logic analyzer.

Trigger Disable A condition or state that cancels the trigger enable. See Restart.

Trigger Enable A state that must occur before the trigger word will be recognized. See Arm.

Trigger Output A synchronizing signal out of a logic analyzer that signifies that trigger conditions are met. It may be used to synchronize external instruments such as oscilloscopes or to arm a second analyzer. See Comparator.

Trigger Qualifier A combinatorial signal (word) that places constraints on satisfying trigger conditions; i.e., the analyzer is triggered only when the specified trigger state and the trigger qualifier conditions occur. See Data Qualified Clocking.

Utility Routine A routine to perform functions auxiliary to the running of other programs. Examples are storage dump routines, bootstrap routines, tape label routines.

Variable Threshold A type of probe that allows user-adjustment of the logic threshold voltage reference. User can adapt the analyzer to different logic families or to test noise immunity. See Threshold.

Waveform A modified timing mode, with an A/D converter as the front-end of the analyzer which performs like a digitizing oscilloscope.

Appendix A Conversion Tables

A.1 ASCII & GPIB Code Chart

B7 B6 B5 BITS	B4 B3 B2 B1	B7 B6 B5 B4	B7 B6 B5 B4	B7 B6 B5 B4	B7 B6 B5 B4	B7 B6 B5 B4	B7 B6 B5 B4	B7 B6 B5 B4	B7 B6 B5 B4	B7 B6 B5 B4	B7 B6 B5 B4	B7 B6 B5 B4	B7 B6 B5 B4					
		CONTROL		NUMBERS SYMBOLS		UPPER CASE		LOWER CASE										
0	BREAK	20	DLE	40	0	60	16	100	0	120	16	140	0	160	16			
0	NUL	10		20	32	30	48	40	@	64	50	80	60	96	70	p	112	
1	GTL	21	S1 LLO	41	1	61	17	101	1	121	17	141	1	161	17			
1	SOH	11	DC1	21	33	31	49	41	A	65	51	81	61	a	97	71	q	113
2		22	S2	42	2	62	18	102	2	122	18	142	2	162	18			
2	STX	12	DC2	22	34	32	50	42	B	66	52	82	62	b	98	72	r	114
3		23	F1	43	3	63	19	103	3	123	19	143	3	163	19			
3	ETX	13	DC3	23	35	33	51	43	C	67	53	83	63	c	99	73	s	115
4	SDC	24	F2 DCL	44	4	64	20	104	4	124	20	144	4	164	20			
4	EOT	14	DC4	24	36	34	52	44	D	68	54	84	64	d	100	74	t	116
5	PPC	25	F3 PPU	45	5	65	21	105	5	125	21	145	5	165	21			
5	ENQ	15	NAK	25	37	35	53	45	E	69	55	85	65	e	101	75	u	117
6		26	F4	46	6	66	22	106	6	126	22	146	6	166	22			
6	ACK	16	SYN	26	38	36	54	46	F	70	56	86	66	f	102	76	v	118
7	TAB	27	F5	47	7	67	23	107	7	127	23	147	7	167	23			
7	BEL	17	ETB	27	39	37	55	47	G	71	57	87	67	g	103	77	w	119
10	GET	30	F6 SPE	50	8	70	24	110	8	130	24	150	8	170	24			
8	BS	18	CAN	28	40	38	56	48	H	72	58	88	68	h	104	78	x	120
11	TCT	29	LABELS	51	9	71	25	111	9	131	25	151	9	171	25			
9	HT	19	EM	29	41	39	57	49	I	73	59	89	69	i	105	79	y	121
12		32	SUB	52	10	72	26	112	10	132	26	152	10	172	26			
10	LF	1A		2A	42	3A	58	4A	J	74	5A	90	6A	j	106	7A	z	122
13		33	ESC	53	11	73	27	113	11	133	27	153	11	173	27			
11	VT	1B		2B	43	3B	59	4B	K	75	5B	91	6B	k	107	7B	{	123
14		34	FS	54	12	74	28	114	12	134	28	154	12	174	28			
12	FF	1C		2C	44	3C	60	4C	L	76	5C	92	6C	l	108	7C		124
15		35	GS	55	13	75	29	115	13	135	29	155	13	175	29			
13	CR	1D		2D	45	3D	61	4D	M	77	5D	93	6D	m	109	7D	}	125
16		36	RS	56	14	76	30	116	14	136	30	156	14	176	30			
14	SO	1E		2E	46	3E	62	4E	N	78	5E	94	6E	n	110	7E	~	126
17		37	UNL	57	15	77	31	117	15	137	31	157	15	177	31			
15	SI	1F		2F	47	3F	63	4F	O	79	5F	95	6F	o	111	7F	DEL (RUBOUT)	127
		ADDRESSED COMMANDS		UNIVERSAL COMMANDS		LISTEN ADDRESSES		TALK ADDRESSES		SECONDARY ADDRESSES OR COMMANDS								

KEY

octal

25 PPU

GPIB code

NAK

ASCII character

hex

15 21

decimal

REF: ANSI STD X3 4-1977
IEEE STD 488-1978

A.2 Hex-Decimal

F E D C		B A 9 8		7 6 5 4		3 2 1 0	
Hex	Decimal	Hex	Decimal	Hex	Decimal	Hex	Decimal
0	0	0	0	0	0	0	0
1	4,096	1	256	1	16	1	1
2	8,192	2	512	2	32	2	2
3	12,288	3	768	3	48	3	3
4	16,384	4	1,024	4	64	4	4
5	20,480	5	1,280	5	80	5	5
6	24,576	6	1,536	6	96	6	6
7	28,672	7	1,792	7	112	7	7
8	32,768	8	2,048	8	128	8	8
9	36,864	9	2,304	9	144	9	9
A	40,960	A	2,560	A	160	A	10
B	45,056	B	2,816	B	176	B	11
C	49,152	C	3,072	C	192	C	12
D	53,248	D	3,328	D	208	D	13
E	57,344	E	3,584	E	224	E	14
F	61,440	F	3,840	F	240	F	15

A.3 Hex-Decimal-ASCII Equivalent For Soft-Keys

KEY	HEX	ASCII	DECIMAL
S1	11	CONTROL-Q	17
S2	12	CONTROL-R	18
F1	13	CONTROL-S	19
F2	14	CONTROL-T	20
F3	15	CONTROL-U	21
F4	16	CONTROL-V	22
F5	17	CONTROL-W	23
F6	18	CONTROL-X	24
LABELS	19	CONTROL-Y	25

