

INSTRUCTION MANUAL

MODEL 136 VCG/VCA GENERATOR

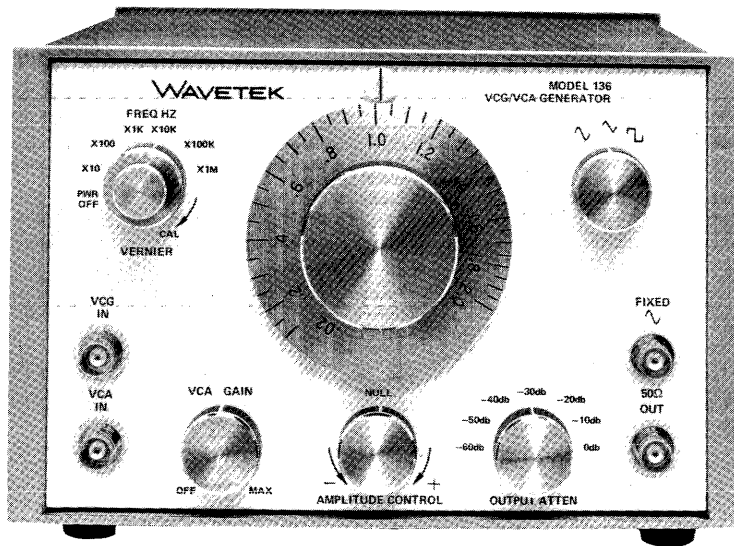

WAVETEK

WARRANTY

All Wavetek instruments are warranted against defects in material and workmanship for a period of one year after date of manufacture. Wavetek agrees to repair or replace any assembly or component (except batteries) found to be defective, under normal use, during this period. Wavetek's sole opinion proves to be defective within the scope of the warranty when returned to the factory or to an authorized service center. Transportation to the factory or service center is to be prepaid by purchaser. Shipment should not be made without prior authorization by Wavetek.

This warranty does not apply to any products repaired or altered by persons not authorized by Wavetek, or not in accordance with instructions furnished by Wavetek. If the instrument is defective as a result of misuse, improper repair, or abnormal conditions or operations, repairs will be billed at cost.

Wavetek assumes no responsibility for its product being used in a hazardous or dangerous manner either alone or in conjunction with other equipment. High voltage used in some instruments may be dangerous if misused. Special disclaimers apply to these instruments. Wavetek assumes no liability for secondary charges or consequential damages and, in any event, Wavetek's liability for breach of warranty under any contract or otherwise, shall not exceed the purchase price of the specific instrument shipped and against which a claim is made.

Any recommendations made by Wavetek for use of its products are based upon tests believed to be reliable, but Wavetek makes no warranty of the results to be obtained. This warranty is in lieu of all other warranties, expressed or implied, and no representative or person is authorized to represent or assume for Wavetek any liability in connection with the sale of our products other than set forth herein.

CONTENTS

| | | | |
|---------------|---|----|--|
| Section One | SPECIFICATIONS | | |
| | Specifications | 1 | |
| Section Two | OPERATION | | |
| | Inspection | 3 | |
| | Operating Controls | 3 | |
| | Operation | 5 | |
| Section Three | CIRCUIT DESCRIPTION | | |
| | General Description | 8 | |
| Section Four | MAINTENANCE | | |
| | Introduction | 10 | |
| | Recommended Test Equipment | 10 | |
| | Checkout and Calibration | 10 | |
| | Removal of Dust Covers | 10 | |
| | Main Board | 10 | |
| | X-Y Multiplier | 12 | |
| | Troubleshooting | 14 | |
| | Removal of Front and Back Panels | 16 | |
| | Replacement of Switch Wafers and Potentiometers | 16 | |
| | Replacement of Sine Converter | 16 | |
| | Frequency Dial Alignment Procedure | 17 | |
| Section Five | DATA PACKAGE | | |
| | Introduction | 18 | |
| | List of Manufacturers | 18 | |

SCOPE OF MANUAL

This manual contains instructions for operating, testing, and maintaining the Wavetek Model 136 VCA/VCG Generator. The Wavetek product-improvement program ensures that the latest electronic developments are incorporated into the Wavetek instruments by the addition of circuit and component changes as rapidly as development and testing permit. Due to the time required to document and print these Instruction Manuals, it is not always possible to get these changes incorporated into the manual. In this case,

data will be found on engineering change sheets at the back of the manual.

SCOPE OF EQUIPMENT

The Model 136 is a precision source of sine, square, and triangle waveforms, with selectable and variable outputs over a dynamic frequency range of 0.2 Hz to 2 MHz. It can be manually operated with easy-to-use, front-panel controls and also offers frequency and amplitude control by external voltage for either dc programming or wideband modulation applications.



SECTION 1

SPECIFICATIONS

SPECIFICATIONS

VERSATILITY

Waveforms

Sine , square , and triangle .

Dynamic Frequency Range

0.2 Hz to 2 MHz



NOTE

The fixed (unmodulated) sine waveform can be used to self-modulate the generator and extend the frequency range to 4 MHz.

Ranges

| | |
|--------|------------------|
| X 10 | 0.2 Hz to 20 Hz |
| X 100 | 2 Hz to 200 Hz |
| X 1K | 20 Hz to 2 kHz |
| X 10K | 200 Hz to 20 kHz |
| X 100K | 2 kHz to 200 kHz |
| X 1M | 20 kHz to 2 MHz |

Outputs

Sine , square , and triangle  selectable; amplitude variable over 40 dB of smooth amplitude control plus 60 dB step attenuator in 10 dB steps, and overlapping vernier control, 50 Ω output impedance; 20 V p-p into open circuit and 10 V p-p into 50 Ω load.

Fixed Sine Output

2.5 V p-p (fixed) into an open circuit. This output is unaffected by any amplitude modulation signal.

Sync Output

Greater than 1 V p-p square wave into open circuit at 600 Ω output impedance.

DC Offset

± 5 V offset (± 2.5 V offset into 50 Ω load) controlled from rear panel; peak amplitude limited by the dynamic range of the amplifier output.

VCA—Voltage Control of Amplitude

Amplitude of the generator may be dc-programmed or ac-modulated by a 0 to 5 volt signal. The voltage control circuitry is bipolar and operates linearly over a 40 dB range. The VCA bandwidth is 4 MHz. The output amplitude at any time is determined by the output attenuator, the step attenuator, and any externally applied voltage.

VCG—Voltage Controlled Generator

Frequency of generator may be dc-programmed or ac-modulated by external 0 to 5 V signal. Voltage control circuitry is capable of 1000:1 deviation. The VCG amplifier has a 100 kHz bandwidth and a slew rate of 0.1 V/ μ s. The instantaneous frequency is the result of the sum of the dial setting and the externally applied voltage.

Stability

Short term $\pm 0.05\%$ for 10 minutes
 Long term $\pm 0.25\%$ for 24 hours
 Percentages apply to amplitude, frequency, and dc offset.

HORIZONTAL PRECISION

Dial Accuracy

$\pm 2\%$ of full scale, 1 Hz to 2 MHz.

Frequency Vernier

One turn equals 1% of full scale.

Time Symmetry

$\pm 1\%$ through X 100K range.

VERTICAL PRECISION

Sine Wave Frequency Response

Amplitude change with frequency:
 Less than 0.1 dB from 0.2 Hz to 200 kHz
 Less than 0.5 dB from 0.2 Hz to 2 MHz

PURITY

Sine Wave Distortion

Less than 0.5% on X 10, X 100, X 1K, X 10K ranges.

Less than 1.0% on X 100K range
Less than 2.0% on X 1M range

Square Wave Rise and Fall Time
Less than 100 ns.

ENVIRONMENTAL

Temperature

All specifications listed, except stability, are for $25^{\circ}\text{C} \pm 5^{\circ}\text{C}$. The generator will operate from 0°C to 55°C .

MECHANICAL

Dimensions

8- $\frac{1}{2}$ " wide, 5- $\frac{1}{4}$ " high, 11- $\frac{1}{2}$ " deep.

Weight

8 lb net, 12 lb shipping.

Power

105 V to 125 V or 200 V to 250 V, 50 Hz to 400 Hz.
Less than 20 watts.

NOTE

All specifications apply for frequencies obtained when dial is between 0.1 and 2 and at 10 V p-p into a 50 ohm load. Prices and specifications subject to change.

It is possible to stop the generator from oscillating by applying a negative voltage when the dial is already set at minimum frequency. Input up to 30 V will not permanently damage the instrument, however.

SECTION 2

OPERATION

INSPECTION

The following procedures should be performed to assure the user that the instrument has arrived at its destination in proper operating condition. Complete calibration and checkout instructions are provided in Section 4 for determining if the instrument is within electrical specifications.

Checking Visually

After carefully unpacking the instrument, visually inspect the external parts for damage to knobs, dials, indicators, surface areas, etc. If damage is discovered, file a claim with the carrier who transported the instrument. Retain the shipping container and packing material for use in case reshipment is required.

Checking Electrically

NOTE

Instruments are normally shipped connected for 115 V power unless 230 V power is ordered. Refer to the end of this section for conversion instructions.

The procedural steps in this paragraph provide a quick checkout of instrument operation. If electrical deficiencies exist, refer to the *Warranty* in the front of this manual. The following test equipment, or equivalent, is recommended for performing this electrical inspection. (Refer to Operating Controls and Figure 2-1 for operating control descriptions.)

| Name | Manufacturer | Model |
|---------------|--------------|-------|
| Oscilloscope | Tektronix | 544 |
| Counter-Timer | Monsanto | 101A |

1. Turn **FREQ HZ** selector to the **X1K** position. (This connects ac power to the unit and establishes the frequency multiplier).
2. Connect oscilloscope to the 50Ω **OUT** connector with 50-ohm terminator.

3. Set frequency dial to the 1.0 mark.
4. Set function to \sim .
5. Rotate **AMPLITUDE CONTROL** through its entire mechanical range.
6. Output signal should be at a null in the center of travel and maximum at each end (10 V p-p).
7. Select \wedge and \sqcap with function selector and check for 10 V p-p amplitude on oscilloscope.
8. Turn frequency dial from maximum counter-clockwise to maximum clockwise positions and check for frequency change.
9. Step **OUTPUT ATTEN** through its range and verify attenuation at each step.
10. Rotate **VERNIER** control and check for frequency change.
11. Set **VERNIER** control at maximum clockwise. Set frequency to 20 Hz with counter. Connect a 0 to +5 Vdc input to the **VCG IN** connector. Slowly increase voltage input from 0 to maximum and check that frequency of output waveform increases from approximately 20 Hz to 2 kHz.
12. Set **AMPLITUDE CONTROL** to null.
13. Connect +2.5 Vdc to **VCA IN** connector with **VCA GAIN** set to off.
14. Rotate **VCA GAIN** to maximum.
15. Check for full amplitude signal out.
16. Repeat Steps 13, 14, and 15 with -2.5 V at **VCA IN** connector.

OPERATING CONTROLS

The operating controls and electrical connections for the Model 136 are shown in Figure 2-1. The listing below discusses each control and its function.

1. **FREQUENCY RANGE SELECTOR/POWER SWITCH** – This 7-position switch selects the generator frequency range. The extreme counter-clockwise position is the power off position.
2. **FREQUENCY VERNIER** – This control allows precision control over the output frequency. A full turn of this control is approximately equal to one minor division of the frequency

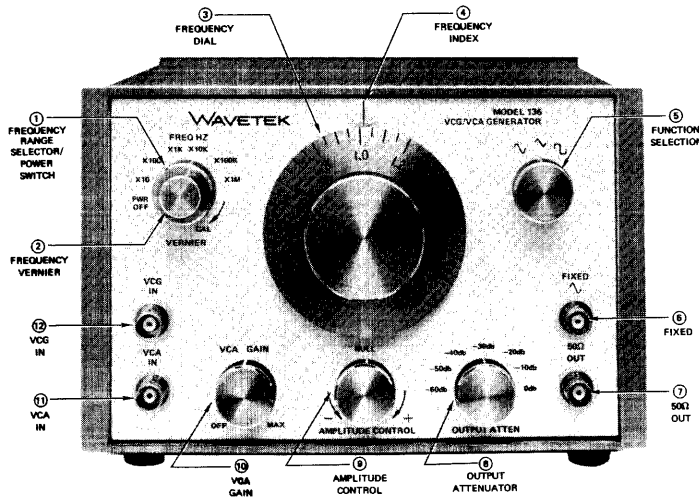

Figure 2-1. Operating Controls.

dial. When in the full clockwise position (CAL), the settings on the main dial will be calibrated.

3. **FREQUENCY DIAL** — The main frequency control. The setting on this dial multiplied by the frequency range setting equals the output frequency of the generator. The frequency **VERNIER** also affects the generator frequency.
4. **FREQUENCY INDEX** — The scribe line indicates the frequency dial setting. The index is illuminated when the unit is on.
5. **FUNCTION SELECTOR** — This selects the waveform that appears at the 50Ω OUT connector. The waveforms are sine \sim , triangle ∇ , square \square .
6. **FIXED** \sim — This connector provides a 2.5 V p-p (fixed) output into an open circuit. This output is unaffected by any amplitude modulation signal.
7. **50Ω OUT** — This connector provides the selected generator output function. The generator may operate into an open circuit providing 20 V peak-to-peak maximum, or into a 50Ω load providing a 10 V peak-to-peak output.
8. **OUTPUT ATTENUATOR** — This controls the

attenuation of the generators output in 10 dB steps. For fine adjustment see **AMPLITUDE CONTROL** (9).

9. **AMPLITUDE CONTROL** — Provides approximately a 40 dB control over the output amplitude of the generator. This control is bipolar, where amplitude is maximum at the full clockwise (+) setting, approaches zero at the mid (null) setting and then increases to maximum at the full counter clockwise (–) setting. When the control is in the + area the phase of the output signal is 180° from the phase in the – area of the control.
10. **VCA GAIN** — Provides a control of the signal applied to the VCA INput and allows for precise setting of amplitude modulation limits.
11. **VCA IN** — This connector allows external control of amplitude. With 0 volts in, the generator output amplitude is determined by the **OUTPUT ATTENUATOR** and the **AMPLITUDE CONTROL**. The voltage applied is attenuated by the VCA GAIN control.
12. **VCG IN** — This connector allows external control of frequency. With 0 volts in, the generator output frequency is determined by the frequency range selected and the frequency

dial setting. A positive VCG voltage will increase this frequency, and a negative voltage will decrease the frequency. Input impedance is 5 k Ω .

DC OFFSET – This rear panel control adjusts the amount of dc or baseline offset above or below signal ground. The detent position gives normal vertical symmetry.

SYNC OUT – This rear panel output provides a synchronizing wave output at the same frequency of the main generator. The output amplitude is greater than 1 V p-p into open circuit at 600 Ω output impedance.

GENERAL NOTES



One-half hour warmup is required for generator to stabilize at specified accuracies.

A 50 ohm termination results in 10 V p-p maximum output level. Open-circuit termination gives 20 V p-p. Loads between these limits provide intermediate maximum output levels.

The frequency VERNIER control must be in full cw position for calibrated-frequency operation over the .1 to 2 dial range. If this control is in full ccw position, dial range is uncalibrated, but extended to approximately 1/1000 of full scale.

OPERATION

Operating as a Function Generator

1. Properly terminate the 50 Ω OUT connector. A 50 Ω termination results in 10 V peak-to-peak maximum output level, and optimum waveform performance. Open circuit termination gives a maximum output of 20 V peak-to-peak. Loads between these limits provide intermediate output levels. When operating into other than a 50 Ω load, slight degradation of the output waveform may be noted particularly at higher frequencies.
2. Select the desired waveform ( ,  , ) with the function selector switch.
3. Select the operating frequency by setting the frequency range selector to the proper multiplier and adjusting the frequency dial to the desired setting.

4. Set the OUTPUT ATTENUATOR for the desired setting. The maximum output of the generator for each attenuator setting is shown in the table.

| Attenuator Position | Maximum Peak to Peak Output into 50 Ω load |
|---------------------|---|
| 0 | 10 V |
| -10 | 3 V |
| -20 | 1 V |
| -30 | 300 mV |
| -40 | 100 mV |
| -50 | 30 mV |
| -60 | 10 mV |

5. Adjust the output level voltage to the desired level with the AMPLITUDE CONTROL.

Operating as a Voltage Controlled Generator (VCG)

1. Properly terminate the output signal.
2. Set function selector for desired waveform.
3. Set FREQ HZ range selector to desired multiplier.
4. Connect external voltage source (dc programming or wideband ac signal) to VCG IN connector.

NOTE

VCG input requires 0 to ± 5 volts for operation over full-scale range, but can withstand many times maximum input.

A negative voltage applied to the VCG input with the dial at the bottom may cause the generator to stop oscillating. Operation in such a manner is not recommended.

5. Set frequency dial as follows:
 - a. For frequency modulation with ac input, set dial for center frequency.
 - b. For increasing frequency sweep with positive dc input, set dial to lower frequency limit.
 - c. For decreasing frequency sweep with negative dc input, set dial to upper frequency limit.
6. Set 20 V P-P MAX control for desired output level.
7. If dc offset is required, switch the rear panel control from the detent position and rotate the control until the required amount of positive or negative offset is obtained.

NOTE

The output of the generator is peak limited. When terminated into 50 Ω the max. output is 10V P-P.

8. To sweep the audio range from 20 Hz to 20 kHz, set the controls to 20 Hz as follows:
- Set the main dial at .02.
 - Set the frequency vernier at the full counter-clockwise position.
 - Introduce a 0 to +5 V ramp into the VCG input connector.
9. The nomograph in Figure 2-2 shows the characteristics of the VCG circuit. Column A gives the frequency dial setting; column B, the VCG input voltage; and column C, the approximate resultant dial frequency. Column C must be multiplied by the frequency range multiplier for the actual output frequency.

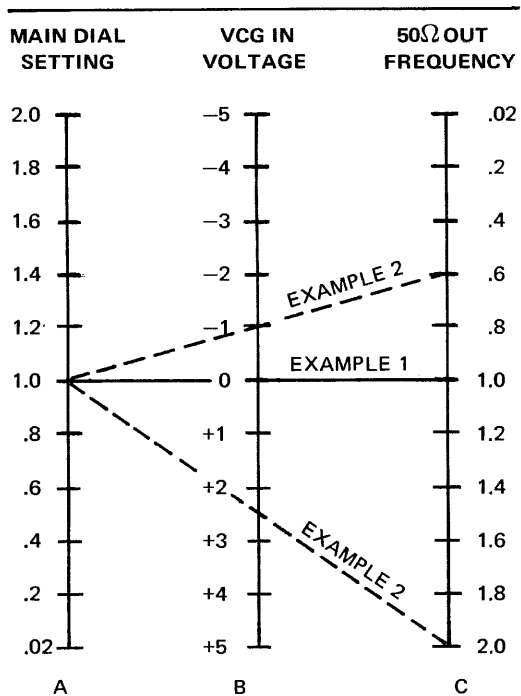

Figure 2-2 - VCG Voltage-to-Frequency Nomograph

In example 1, the dial is set at 1, and 0 volts is applied to the VCG input. Extend a straight line from 1 (dial setting) through 0 volts (VCG voltage) and obtain a dial frequency of 1. For the total output frequency multiply the range by 1. With the same dial setting, example 2 shows the results of using a ramp from -1 volts to +2.5 volts for the VCG voltage. This results in a swept output from .6 to 2.0 on the dial. Remember to multiply the dial times the range.

Operating as an Amplitude Modulated Generator

In using the VCA capability of the generator, consider the amplitude as a multiplier as shown in Figure 2-3.

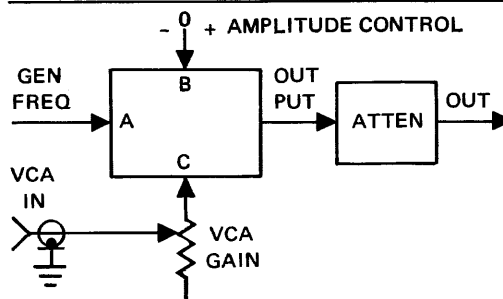
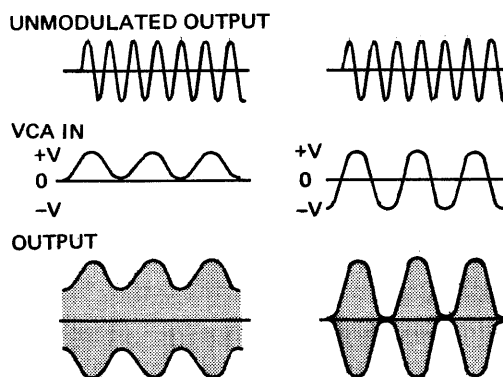

Figure 2-3. Multiplier Block Diagram

The output of the generator is the product of the input amplitude multiplied by the sum of the two control voltages, or $output = A (B + C)$. If the sum of the control voltage is positive, and greater than unity the amplitude will increase. If the sum goes negative the amplitude changes accordingly and the signal phase is reversed. If the sum voltage is zero, the output level will be approximately zero. The chart below shows the effect of various types of modulation.



To set up the generator for amplitude modulation:

- Adjust the function generator as shown under Operating as a Function Generator.
- Turn the VCA GAIN to OFF and connect the modulating signal to the VCA IN connector.
- Set the generator amplitude to the desired unmodulated level.

4. Increase the VCA GAIN control to achieve the desired modulation level. Note that if the VCA input is a positive voltage the unmodulated level will increase. It is possible to exceed the maximum specified output level of the generator, causing clipping and waveform distortion. If this is observed, decrease the amplitude control or the gain control until clipping is no longer observed.

Operating as a Suppressed Carrier Modulator

1. Adjust the function generator as shown under Operating as a Function Generator.
2. Turn the VCA GAIN to OFF and connect the modulating signal to the VCA IN connector.
3. Set the generator amplitude to null with the AMPLITUDE CONTROL, adjusting for minimum output.
4. Increase the VCA GAIN control to achieve the desired suppressed carrier.

Operation as a Double Frequency Sine Only Generator

1. Properly terminate the output connector.
2. Set the function to \sim .
3. Set the output level to null with the amplitude control.
4. Connect the FIXED \sim output to the VCA IN with the VCA GAIN turned to off.
5. Set frequency range and dial to one-half the desired output frequency.
6. Increase VCG GAIN control to desired output level.
7. The dc component of the output signal may now be removed with the output offset control on the rear panel.

Converting to 230-Volt Line Power

Instruments are shipped from the factory with the power transformer connected for 115-volt line power, unless ordered for 230-volt use. Converting a 115-volt unit for 230-volt operation is a simple matter.

1. Remove power cord.
2. Loosen two captive thumb screws on rear panel and remove panel.
3. The conversion switch is located on the chassis. Use a thin-bladed screwdriver to move the 115-230

switch to the 230 position.

4. Replace 1/4-ampere fuse with a 1/8-ampere fuse of the same type.

Connect Signal and Chassis Grounds

The instrument is shipped from the factory with the signal ground floating above chassis ground, unless otherwise specified. A common signal/chassis ground can be obtained as follows:

1. Remove power cord.
2. Loosen two captive thumb screws on rear panel and remove panel.
3. Solder a jumper wire between the ground lugs (green wires) of the SYNC OUT connector and the power connector (Figure 2-4).

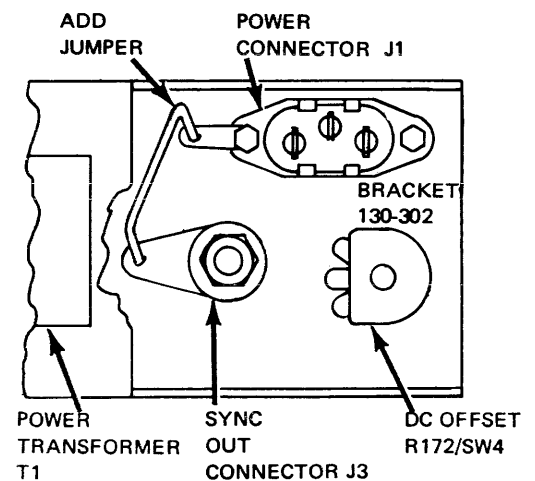

Figure 2-4. Common Ground Connection Diagram

Converting Output Impedance to 600 ohms

Unless otherwise specified, this instrument was shipped with 50 ohm output impedance, but can be converted to 600 ohm output if needed. Place a 550Ω resistor in series with the wire leading from the center tap of the 50Ω OUT BNC and the attenuator switch.

SECTION 3

CIRCUIT DESCRIPTION

GENERAL DESCRIPTION

Refer to the block diagram of the Model 136 Function Generator, Figure 3-1.

Basically, a square wave is applied to the input of an integrator composed of a wideband differential dc amplifier, integrating resistor and capacitor. The output of the integrator is fed into the hysteresis switch. The hysteresis and output switches function like a Schmitt trigger with the limit points set at the waveform extremes, firing when the triangle wave reaches +1.25 volts and -1.25 volts. The firing sets the hys-

teresis and the output switches which reverse the square wave fed into the integrator, causing the triangle wave to reverse direction. The result is simultaneous generation of a square wave and triangle wave of the same frequency with the positive half cycle of the square wave coincident with the negative slope of the triangle wave.

The frequency of oscillation is determined by the magnitude of the capacitor across the integrator and the amplitude of the current into the integrator. The capacitance across the integrator is changed by rotating the frequency Hz selector. The amplitude of the

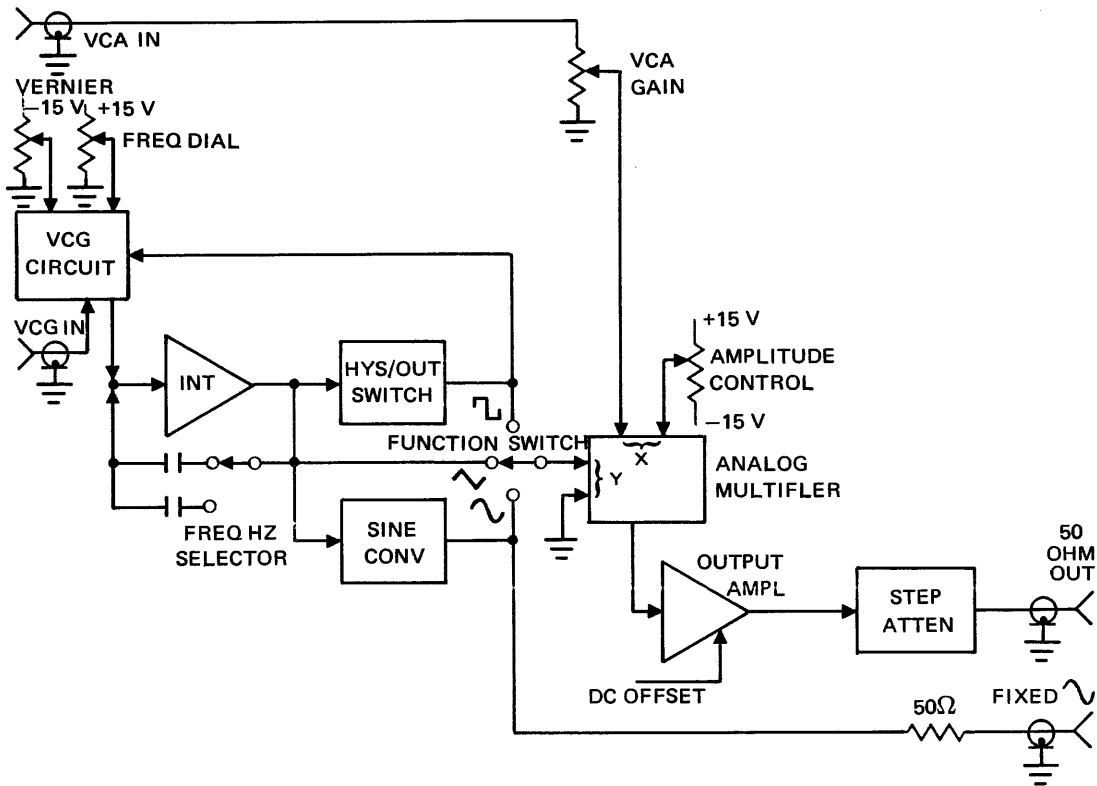

Figure 3-1. Functional Block Diagram.

current into the integrator is determined by four parameters which are summed in the VCG circuit: 1) the ± 5 volt square wave fed from the hysteresis switch, 2) the frequency dial voltage, 3) the frequency vernier voltage, and 4) the VCG analog voltage input.

The sine wave is produced by shaping the triangle wave. The triangle wave is fed into a shaping network composed of resistors and diodes. As the triangle wave voltage passes through zero, loading of the triangle wave is minimal and thus the slope is maximum. As the triangle wave voltage increases; diodes with current limiting resistors conduct, successively, causing the slope of the output to be less.

Since the diode break points are mathematically computed and fitted to the true sine shape, the resultant waveform is an almost pure sine wave. The circuitry is

completely symmetrical about ground, using a complementary pair of diodes on each break point. The sine wave produced by shaping is considerably less in amplitude than the triangle wave input and is thus amplified to be equal to the triangle wave.

The triangle wave output of the integrator, the sine wave output, and the square wave coupled through a divider are fed to the function selector switch, with a 50Ω fixed sine output brought out.

The function selector switch supplies the internal signal to one side of the analog multiplier. The other multiplier input is the joint signal of the VCA input through the VCA gain control and the amplitude control. This proportional signal is fed through the output amplifier into a precision attenuator to the 50Ω output.

SECTION 4 MAINTENANCE

INTRODUCTION

This section provides instructions for testing, calibrating, troubleshooting, and repairing the Model 136. The instructions are concise and for the experienced electronics technician or field engineer. Wavetek maintains a factory-repair department for those customers not possessing the necessary personnel or test equipment to maintain the instrument. If an instrument is returned to the factory for calibration or repair, a detailed description of the specific problem should be attached to decrease the turnaround time. Test point and adjustment locations are illustrated in Section 5.

RECOMMENDED TEST EQUIPMENT

Table 4-1 contains a list of recommended test equipment. Any test equipment having equivalent accuracies may be substituted for those listed.

Table 4-1. TEST EQUIPMENT

| Name | Required Characteristics | Recommended | |
|---------------------------|------------------------------|--------------------------|-------|
| | | Manufacturer | Model |
| Oscilloscope | To 30 MHz | Tektronix | 544 |
| Plug-In | Dual channel | Tektronix | 1A1 |
| Plug-In | Peak mV measuring capability | Tektronix | 1A5 |
| Distortion Analyzer | To 600 kHz | Hewlett Packard | 334A |
| Spectrum Analyzer Display | To 50 MHz | Hewlett Packard | 141S |
| IF Section | | Hewlett Packard | 8552A |
| RF Section | | Hewlett Packard | 8553L |
| Voltmeter | Millivolt dc measurement | 1 mV Resolution | |
| Counter | To 10 MHz | 0.1% of reading accuracy | |

CHECKOUT AND CALIBRATION

The following paragraphs provide complete sequential calibration procedures for the Model 136. Instrument checkout procedures are indicated by a checkmark (✓) following the procedure title. A quick checkout of the instrument can be performed by comparing the indicated parameters with the tolerances given in the Specifications of Section 1.

NOTE

The entire calibration procedure must be read first to determine initial control settings and test equipment connections before attempting checkout.

Preliminary Procedures

1. Set FREQ HZ selector to the X1K position, dial at 2.0, and VERNIER control maximum cw.
2. Allow one-half hour for warmup.

REMOVAL OF DUST COVERS

To gain access for calibration or maintenance, proceed as follows:

- a. Remove power cord.
- b. Loosen the two knurled captive screws on the rear panel.
- c. Pull off the rear panel.
- d. Remove the cover.

MAIN BOARD

Power Supply Regulation

1. Connect voltmeter between TP1 (common) and TP2 (+) on Main Board. Adjust R104 for +15 Vdc ± 100 mV.
2. Connect voltmeter between TP1 (common) and TP3 (-). Since the negative supply is referenced to the +15-volt supply, the voltmeter should indicate -15 Vdc ± 100 mV.

Square Wave Amplitude Symmetry

1. Set function selector to \square .
2. Connect oscilloscope with 1A5 plug-in to coaxial-wire lug on function switch.
3. Adjust R121 until square-wave negative peak is equal in amplitude to positive peak ± 5 mV.

Triangle Amplitude

1. Set frequency dial for 2.0 (X1K range) and function selector to ∇ .
2. Connect oscilloscope, with 1A5 plug-in, to red-wire lug on function switch.
3. Adjust R56 on main board for positive peak at +1.25 volts ± 5 mV (see sketch).

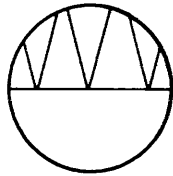

Negative Peak

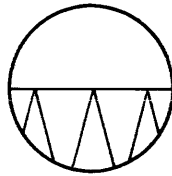

Positive Peak

4. Adjust R59 for negative peak at -1.25 volts ± 5 mV.

First VCG Null \checkmark

1. Connect oscilloscope to 50Ω OUT connector.
2. Set FREQ HZ selector to X1K. Set dial at 1/100 of full scale (.02).
3. Short and open VCG IN to signal ground (outside of BNC connector) while monitoring output frequency variation. Adjust R11 for minimum frequency change.

Time Symmetry \checkmark

1. Connect unit and oscilloscope, with 1A1 plug-in set for alternate display, as shown in Figure 4-1.
2. Set FREQ HZ selector for X100K with VERNIER in full cw position (\square function).
3. Set frequency dial for 2 kHz on oscilloscope (1/100 of full scale).
4. Adjust R28 for time symmetry at 100:1 frequency ratio.
5. Turn VERNIER fully ccw and adjust R22 for bottom-of-dial time symmetry.
6. Repeat Steps 4 and 5, as necessary, for optimum symmetry.

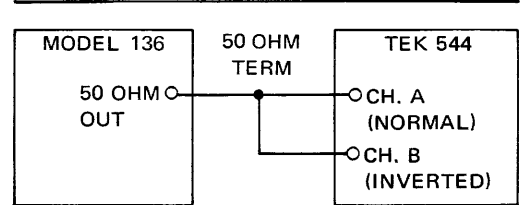

Trigger: Internal Time Base: 50 microseconds/cm for 1/100 of 200 kHz
 Display: Alternate 500 microseconds/cm for 1/1000 of 200 kHz

Figure 4-1.

Time Symmetry Measurement for Test Setup

7. Check for waveform time symmetry at the .2 and 2 frequency-dial settings.
8. Check for 1000:1 frequency ratio @ X100K, dial full cw, vernier full ccw.
9. If necessary, adjust R8 for slightly $>1000:1$ ratio.

Frequency Calibration

1. Connect counter to 50Ω OUT connector with 50Ω terminator.
2. Set FREQ HZ selector to X10K and VERNIER fully cw.
3. Align 2.0 dial mark with the dial indicator index and alternately switch from X10K to X1K range while adjusting R4 for a balanced error between the two positions.
4. Set FREQ HZ selector to X100K and dial at 2.0.
5. Adjust C16 to obtain 200.0 kHz on counter display.
6. Set FREQ HZ selector to X1M. Adjust C12 to obtain 2.00 MHz on counter display.
7. Dial alignment — No alignment is necessary if the dial is the push-on type. If it has a set screw, consult the dial alignment procedure at the end of this section.

Sine, Distortion, Amplitude, and Balance \checkmark

1. Set FREQ HZ selector for X1K (VERNIER full cw), function selector to \sim and frequency dial at 2.0.
2. Connect oscilloscope to FIXED \sim output unterminated.
3. Adjust R133 to obtain 2.5 V p-p ± 25 mV output.
4. Adjust R128 to balance output.

5. Connect the unit, distortion analyzer, and oscilloscope as shown in Figure 4-2.

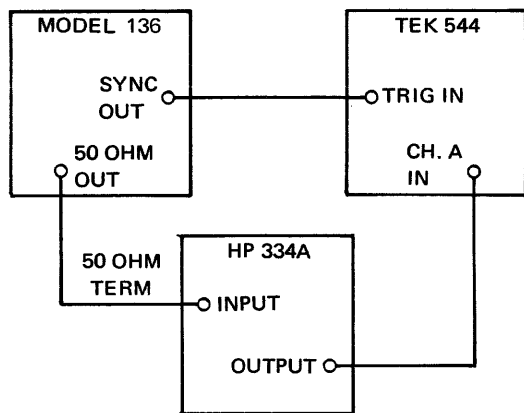
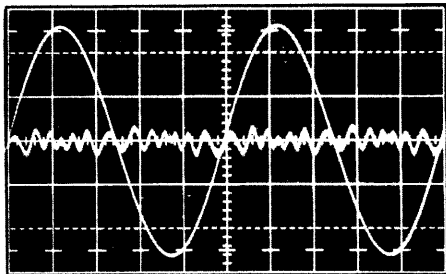

Figure 4-2. Distortion Analysis Test Setup

6. Adjust R126 and R127 for minimum sine distortion (see photo).



7. Set FREQ HZ selector by X10K.
8. Repeat Step 6 to obtain least distortion at both X1K and X10K ranges.
9. Repeat Steps 2, 3, and 4.
10. Connect spectrum analyzer and check sine distortion at 2 MHz.

X-Y MULTIPLIER

VCA Open Circuit Voltage

1. Set frequency to 200 Hz $\pm 10\%$.
2. Set function to \square .
3. Set OUTPUT ATTENUATOR to 0 dB.
4. Set VCA GAIN to maximum.
5. DC OFFSET control (rear panel) switched off.
6. Connect a single-ended scope input to the 50 Ω OUT

7. Short the VCA input.

NOTE

A 50 Ω line termination is an adequate short for this purpose.

8. Set the AMPLITUDE CONTROL for an output signal level less than 50 mV peak-to-peak.

NOTE

It may be helpful to this step to reduce the dc offset in the output with potentiometer R8. This need only be done roughly as it will be set accurately later.

9. Remove the short from the VCA input and adjust potentiometer R1 for the same signal level that was set before the short was removed.
10. Adjust potentiometer R1 to a value which allows the amplitude, shape, and phase of the signal to remain constant when the short is removed.

NOTE

To test the quality of this adjustment tune the AMPLITUDE CONTROL to null and turn the VCA GAIN potentiometer from maximum to off with the VCA IN open. The peak-to-peak amplitude of the null signal should change by less than 10 mV when this is done.

Input Compensation

1. Switch the function to \wedge .
2. Set an amplitude of 1 V p-p $\pm 10\%$.
3. Decrease amplitude until the straight sides of the triangle wave become parabolic.

NOTE

Avoid decreasing the amplitude in the first step so far that the waveform folds over into a null.

4. Adjust potentiometer R7 for an unwarped triangle.

NOTE

It is not necessary to do this with great care at the initial higher amplitudes.

- Repeat the above two steps until the triangle is down to about 50 mV peak-to-peak.

NOTE

It is normal for the 50 mV triangle to be fuzzy and somewhat distorted, but the potentiometer should be set for optimum linearity. Increase scope sensitivity as necessary to observe the signal.

VCA Null

- Set the function to .
- Set the VCA GAIN at maximum.
- Tune the AMPLITUDE CONTROL carefully to null.

NOTE

Less than 20 mV peak-to-peak is an adequate null.

- Connect a BNC cable between the FIXED  output and the VCA IN.
- Adjust potentiometer R4 so the positive peaks of the output waveform are equal in amplitude.

NOTE

The peaks will be about +3 V if the output is terminated in 50Ω or +6 V unterminated.

The DC OFFSET control at the rear may be used to advantage in this step by centering the positive peaks on the scope with dc offset and increasing the vertical sensitivity. Adjacent peaks should differ from each other by less than ½% of the peak value.

Linearity

- Check to see that the DC OFFSET potentiometer at the rear is switched out.
- Connect the FIXED  output and the 50Ω OUT to the two inputs on a differential scope.

NOTE

The 50Ω OUT should be terminated in a 50Ω load and the FIXED  output should not be terminated.

- Set the OUTPUT ATTENUATOR to -10 dB.

- Set the function to .
- Tune the AMPLITUDE CONTROL for a null indication on the scope.

NOTE

This should occur at about ½ amplitude on the negative side of the amplitude control. If it does not, check to see that the scope is set up for a differential measurement.

- Adjust potentiometer R6 and the AMPLITUDE CONTROL jointly for an improved null.

NOTE

The null signal should be a low level sine wave of three times the frequency of the fundamental output of the generator.

Output Damping

- Connect the 50Ω OUT to a single-ended scope input.

NOTE

The bandwidth of the scope should be at least 50 MHz. Connect the generator to the scope with a coaxial line about 1-½ feet long without a termination.

- Set the function to .
- Set the OUTPUT ATTENUATOR to 0 dB.
- Set the VCA GAIN to off.
- Set the frequency to 1 MHz.
- Set the amplitude to 20 V p-p unterminated.
- Adjust C16 for proper damping.

NOTE

Set for fastest rise time with no overshoot. Check for waveform quality at full scale output on each end of the amplitude control potentiometer.

High Frequency Null Compensation

- Set frequency to 1 MHz.
- Set function to .
- Tune AMPLITUDE CONTROL for null on the scope display.

- Adjust potentiometer R5 for minimum amplitude of the disturbances at the square wave switching times.

NOTE

Increase the scope sensitivity as necessary to observe the null.

Output Offset

- Check to see that the DC OFFSET potentiometer at the rear is switched OFF.
- Set frequency to 200 Hz $\pm 10\%$.
- Set AMPLITUDE CONTROL for a null signal.

NOTE

A signal of less than 50 mV peak-to-peak is an adequate null for this step.

- Adjust potentiometer R8 for zero volts dc.

NOTE

Ignore the signal voltage and set the dc component to less than 10 mV. This setting may be made with a dc voltmeter, but it is not essential.

TROUBLESHOOTING

Basic Techniques

Troubleshooting the Model 136 requires no special techniques. Listed below are a few reminders of basic electronics fault isolation.

- Check control settings carefully. Many times an incorrect control setting, or a knob that has loosened on its shaft, will cause a false indication of a malfunction.
- Check associated equipment connections. Make sure that all connections are properly connected to the correct connector.
- Visually check the interior of the instrument. Look for such indications as broken wires, charred components, loose leads, etc.
- Perform the checkout procedure. Many out-of-specification indications can be corrected by performing specific calibration procedures.

Troubleshooting Chart

Table 4-2 provides a list of possible malfunction

symptoms, probable causes, prescribed remedies, test points at which measurements are made, and parameter tolerances at these points. To use the troubleshooting chart, locate the symptom listed in Column 1 and follow the corresponding procedures. Localize the fault to a specific stage by checking the parameters given for the major test points. Then check the dc operating voltages at the pins of solid-state devices. Check associated passive elements with a high input impedance ohmmeter (power off) before replacing a suspected semiconductor element.

Main Generator Troubleshooting Hints

The interactive nature of a closed loop presents a somewhat special problem when approached from a troubleshooting standpoint. The simplest way to reduce problem complexity is to open the loop, thereby removing the interaction. The basic units of the loop can then be tested individually. The following step-by-step procedure describes how this is done. (The generator loop is all contained on the main board.)

- Set instrument controls for 10 V p-p, 2 kHz sine-wave output.
- Check at coaxial-wire lug of function selector switch for a 2.5 V p-p square wave. If normal, check multiplier section or output attenuator.
- Unsolder and lift the end of R51 (TP7). This is the output of the integrator and input to the hysteresis switch. The generator loop has now been opened.
- Inject a 2.5 V p-p triangle waveform into the hysteresis switch. input lead (TP7).
- Check at the coaxial-wire lug of the function selector switch for a 2.5 V p-p square wave at the injected frequency.
 - If present, hysteresis and output switches are okay. Proceed to Step 6.
 - If abnormal, check Q6-Q16 stages.
- Vary frequency dial from ccw to cw while observing TP11 with a scope. Voltage at this point should remain at 0 volts throughout dial rotation. If a voltage variation is observed, check IC1 stage.
- Vary frequency dial from ccw to cw while observing TP4. Voltage reading should vary from 0 to approximately -6 volts. If voltage does not vary, check IC2 stage and IC1 stage.
- Vary frequency dial from ccw to cw while observing TP9. Voltage reading should remain at 0 volts. If voltage varies check IC3 stage.
- Vary frequency dial from ccw to cw while observing TP10. Voltage should vary from 0

Table 4-2. TROUBLESHOOTING CHART

| Symptom | Probable Cause | Corrective Procedures |
|---|-----------------------------------|--|
| No outputs at 50Ω OUT connector | Blown fuse | Replace F1 a. 1/4A–115 Vac b. 1/8A–230 Vac |
| | Power supply | Check TP1/TP2 for +15 V; TP1/TP3 for –15 V; TP1/TP5 for +6 V; TP1/TP6 for –6 V. Troubleshoot associated regulator. |
| | Output amplifier | Check at wiper (grn/wht wire) of function selector switch for waveform as selected by position of switch. a. If waveform is present, troubleshoot output amplifier. b. If no waveforms are present, refer to Main Generator Troubleshooting Hints . |
| No sine wave output | Sine amplifier | Check for 260 mV p-p sine wave at pin 4 of IC8. a. If present, check IC8 circuit. b. If <i>not</i> present, check A1 circuit. <i>NOTE:</i> Triangle wave must be present at pin 2 of A1 to obtain sinewave output. |
| No triangle, sine, or square wave. | Generator loop | Refer to Main Generator Troubleshooting Hints . |
| All waveforms low in amplitude. | Power amplifier | a. Check front-panel amplitude control. b. Perform balance adjustment for power amplifier. |
| | Power supply | Check for proper voltages. |
| Frequency out of tolerance | Power supply | Check for proper power supply voltages as stated above. |
| | Maladjustment | Perform calibration procedure. |
| Sine wave not in spec | Maladjustment | Perform Sine Distortion, Amplitude, and Balance adjustment. |
| | Sine converter | Check for 260 mV p-p sine wave at pin 4 of IC8. a. If normal, check sine amplifier IC8. b. If abnormal, check A1 circuit. |
| Time symmetry of waveforms not correct. | Maladjustment | Perform Time Symmetry and frequency adjustments. |
| Amplitude Control inoperative | Multiplier failure | Trouble shoot multiplier and output amplifier. |
| Output Attenuator inoperative | Atten. Switch failure | Check for proper output at amplifier. |
| DC Offset inoperative | Offset pot failure or broken wire | Check potentiometer action and inspect wiring. |

volts to approximately +6 volts. If voltage does not vary, check IC2 stage and IC3 stage.

10. Vary frequency dial from ccw to cw while observing TP8. Voltage reading should remain at 0 volts. If voltage varies, check IC4 and IC5 stages.
11. Re-install R51.

X-Y Multiplier Troubleshooting Hints

The multiplier section is so integrated with the output amplifier section that locating the problem part can be difficult. However, the output attenuator is quite independent so that a trouble in the attenuator does not appear to be somewhere else.

1. Pin 2 of IC1 is a summing node to the operational amplifier Q1 and Q2. It should be at 10 V DC at all times. If it is not, the fault may be either the operational amplifier or the IC.
2. Pin 14 of IC1 is a summing node to the operational amplifier Q3 and Q4. It should be at 10 V DC at all times. If it is not, the fault may be either the operational amplifier or the IC.
3. The emitters of Q1 and Q3 are the outputs of the two operational amplifiers just mentioned. A low amplitude copy of the proper signal should appear at both of these points with about 12 V of DC offset and in opposing phase. The output offset is accomplished by feeding unequal currents to the two summing nodes.
4. The transistors Q5 through Q12 comprise the output amplifier proper which is a bridge differential type. The two bases of Q5 should have identical AC and +10 V DC signals.

Removal of Front and Back Panels

1. To gain access to any part mounted on bracket assembly behind rear panel, proceed as follows:
 - a. Remove rear panel and dust cover as described in Removal of Dust Cover.
 - b. Remove one heat-sink mounting screw.
 - c. Remove one transformer mounting-block screw from bottom of board.
 - d. Remove the two screws, lock washers, and hex-nuts holding two wafers of FREQ HZ switch to bracket assembly.
 - e. Remove four bracket-assembly retaining screws.
 - f. Carefully pull bracket assembly to rear to ob-

tain work room. Enough slack is available in the wiring for all normal operations.

2. To remove the front panel, proceed as follows:
 - a. Remove rear panel and dust cover as described in Removal of Dust Cover.
 - b. Remove all knobs.
 - c. Disconnect BNC connections.
 - d. Remove ½ inch nut from frequency dial potentiometer shaft.
 - e. Pull light bulb from indicator lens.
 - f. Remove four front-panel retaining screws.
 - g. Carefully pull off front panel.

REPLACEMENT OF SWITCH WAFERS AND POTENTIOMETERS

1. To replace FREQ HZ switch wafer C or D or the VERNIER potentiometer, proceed as follows:
 - a. Remove rear panel and dust cover as previously described.
 - b. Separate bracket assembly from chassis as previously described.
 - c. Tag and unsolder leads to part being replaced.
 - d. Pull defective part off shaft and repair or replace with recommended replacement part.
2. To replace FREQ HZ switch wafer A or B, proceed as follows:
 - a. Remove rear panel and dust cover as previously described.
 - b. Remove front panel as previously described.
 - c. Tag and unsolder wires to switch wafers A and B.
 - d. Unsolder wafer B PC-tabs from printed circuit board.
 - e. Lift switch shaft slightly to free PC-tabs, rotate switch shaft so wafers clear board parts, and pull shaft end free of rear-mounted wafers C and D.
 - f. Repair or replace defective part.
3. To repair or replace function selector wafers, proceed as follows:
 - a. Remove rear panel and dust cover as previously described.
 - b. Tag and unsolder wires to defective part.
 - c. Unsolder potentiometer PC-tabs, lift shaft slightly to free tabs, rotate switch shaft so wafers clear board parts, and pull switch/potentiometer assembly out of front panel hole.
 - d. Repair or replace defective part.

REPLACEMENT OF SINE CONVERTER

1. Remove rear panel and dust cover as previously described.

2. Unsolder the five pins of sine converter A1 from top of the printed circuit board, using a solder syringe.
3. Lift assembly from bottom of the board; a thin pencil-type soldering iron can be used, if necessary, to apply temporary heat during removal.

FREQUENCY DIAL ALIGNMENT PROCEDURE

If the generator has a frequency dial secured to the main shaft by a set screw, the following procedure should be followed to align the dial:

1. Connect counter to 50Ω OUT connector with a 50Ω terminator.
2. Set FREQ HZ selector to X10K and VERNIER fully cw.
3. Set frequency dial potentiometer for 2 kHz on the counter display.
4. Align 0.2 dial mark with the dial indicator index and tighten set screw.
5. Align 2.0 dial mark with the dial indicator index and adjust R4 to obtain maximum dial accuracy on bottom four ranges.
6. Set FREQ HZ selector to X100K and dial fully cw.
7. Turn frequency VERNIER fully ccw.
8. Adjust R8 for 150 ± 20 Hz on counter.
9. Check that generator continues to oscillate over the full range of the frequency VERNIER dial. If not, readjust R8.
10. Turn VERNIER fully cw (CAL) and set frequency dial to align 2.0 with index mark.
11. Adjust C16 to obtain 200.0 kHz on counter display.
12. Set FREQ HZ selector to X1M. Adjust C12 to obtain 2.00 MHz on counter display.

SECTION 5

DATA PACKAGE

INTRODUCTION

This section contains data packages for the Model 136. Each data package is a quick-access document, containing maintenance data arranged for convenient viewing of the schematic diagram and all supporting data. Each data package includes a parts-location illustration; a replaceable parts list; voltage/waveform data; and a schematic diagram. Voltage and waveform data are provided on the diagrams at indicated test points as an aid to troubleshooting. Also, a list of manufacturers is included in this section.

LIST OF MANUFACTURERS

| | | | |
|--------------------------|---|-----------------------|--|
| American Radionics . . . | American Radionics, Inc. Danbury, Connecticut | Fair . . . | Fairchild Semiconductor Corporation Palo Alto, California |
| Amp | Amp, Inc. Harrisburg, Pennsylvania | IBM | IBM Industrial Products White Plains, New York |
| ARCO | Arco Electronics Great Neck, L.I., New York | IMB | IMB Electronics Products Santa Fe Springs, California |
| Boots | Boots-Townsend Aircraft Santa Ana, California | IRC | IRC Inc. Philadelphia, Pennsylvania |
| Corn | Corning Glass Works Bradford, Pennsylvania | Kings | Kings Electronic Co., Inc. Tickahoe, New York |
| CRL | Centrallab Division of Globe-Union Milwaukee, Wisconsin | Littelfuse | Littelfuse Des Plaines, Illinois |
| CTS | Chicago Telephone Systems Los Angeles, California | Motorola | Motorola Semiconductor Products Phoenix, Arizona |
| Electro | Electro Cube, Inc. San Gabriel, California | Mura | Mura Corp. Great Neck, L.I., New York |
| Elco | Elco Corp. Willow Grove, Pennsylvania | RCA | RCA Semiconductor Division Somerville, New Jersey |
| Eipac | Eipac Incorporated Fullerton, California | Richey | Richey Electronics Nashville, Tennessee |
| Erie | Erie Technological Products, Inc. Erie, Pennsylvania | Semtech | Semtech Corporation Newbury Park, California |
| | | HHSmith | Herman H. Smith, Inc. Brooklyn, New York |
| | | Sprague | Sprague Electric Company North Adams, Massachusetts |
| | | Stack | Stackpole Carbon Company St. Marys, Pennsylvania |
| | | Switchcraft | Switchcraft, Inc. Chicago, Illinois |
| | | TI | Texas Instruments, Inc. Dallas, Texas |
| | | USECO | USECO Inc. Mt. Vernon, New York |
| | | Wakefield | Wakefield Engineering, Inc. Wakefield, Massachusetts |
| | | Wavetek | Wavetek San Diego, California |

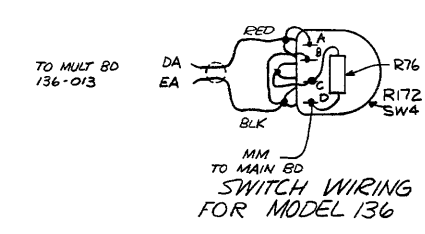
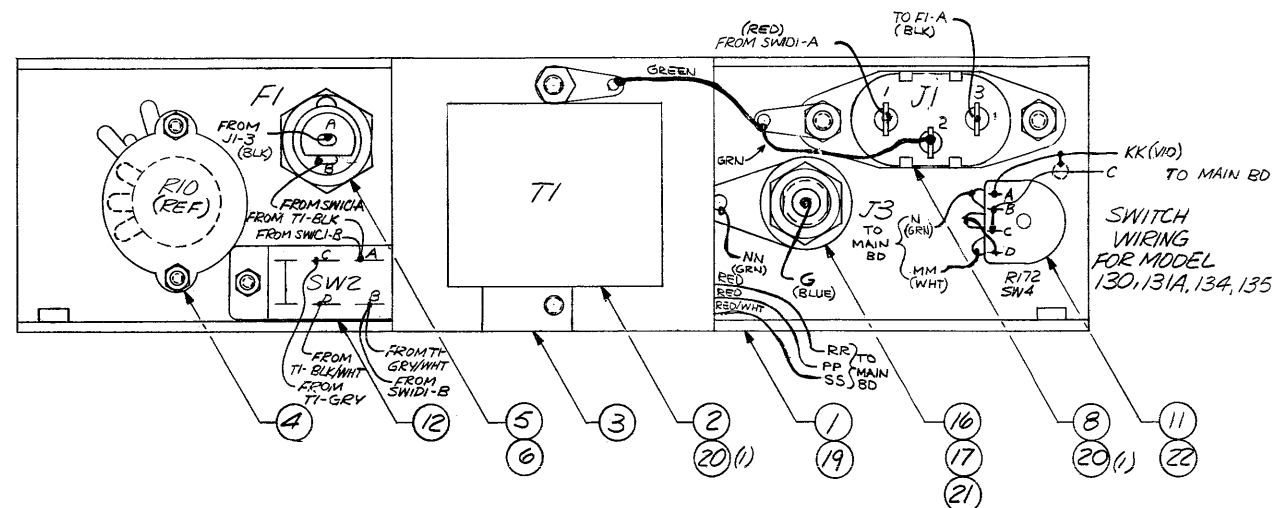

| PARTS LIST | | | | | |
|------------|-----------|-------------------------------|------------|--------------|-----|
| ITEM | REF DES | DESCRIPTION | MFGR | MFGR NO | QTY |
| 1 | | BRACKET | WAVETEK | B130-302F | 1 |
| 2 | T1 | TRANSFORMER | | C130-500 | 1 |
| 3 | | TRANSFORMER BRACKET | | A130-306 | 1 |
| 4 | | STANDOFF (MODEL 130ONLY) | HH SMITH | 2342 | 2 |
| 5 | F1 | FUSE 1/4AMP-115V | LITTELFUSE | 313-250 | 1 |
| 6 | | FUSE HOLDER | | 342012 | 1 |
| 7 | | FUSE 1/8AMP, 230V | | 313-125 | 1 |
| 8 | J1 | POWER RECEPTACLE | SWITCHRAFT | AC3-G | 1 |
| 9 | R76 | RESISTOR 1/2W, 10% CARBON 24K | STACKPOLE | RC206F242K | 1 |
| 10 | | | | | |
| 11 | R172, SW4 | DC OFFSET SWITCH 10K/SPST | CTS | UL5186 | 1 |
| 12 | SW2 | 115-230V SWITCH | SWITCHRAFT | 2625 6LF | 1 |
| 13 | | | | | |
| 14 | | | | | |
| 15 | | | | | |
| 16 | J3 | BNC CONNECTOR | KING | KCT946 | 1 |
| 17 | | SHOULDER WASHER | SMITH | 266B | 2 |
| 18 | | | | | |
| 19 | | FASTENERS #6-32 | SOUTHCO | 74-11-106-13 | 4 |
| 20 | | SOLDER LUG | H.W. SMITH | 1414-4 | 2 |
| 21 | | SOLDER LUG | | 1497 | 1 |
| 22 | | KNOB | ELMA | 020-222 | 1 |
| 23 | | MICA INSULATOR | WAVETEK | A740-307A | 1 |
| 24 | | | | | |
| 25 | | | | | |

FOR 115V MODEL
FOR 230V MODEL
MODEL 136 ONLY

| | | | | |
|---|---------|----------------------------|----------|---------------|
| C | ECN 341 | 16 | 11-18-69 | J.B. |
| B | COP 29 | 16 | 11-18-69 | J.B. |
| A | ECN 283 | 16 | 11-18-69 | J.B. |
| rev | ecn | by | date | app. |
| tolerance unless otherwise specified .XXX ± .010 .XX ± .030 | | | | |
| WAVETEK san diego, calif | | | | |
| scale | N/A | by | 7-21-69 | app. J. Ch... |
| material | N/A | title ASS'Y, BRACKET | | |
| finish | N/A | model no. | 130-136 | rev C |
| this document contains proprietary information and design rights belonging to WAVETEK and may not be used or reproduced for any reason except calibration, operation and maintenance without written authorization. | | | | |

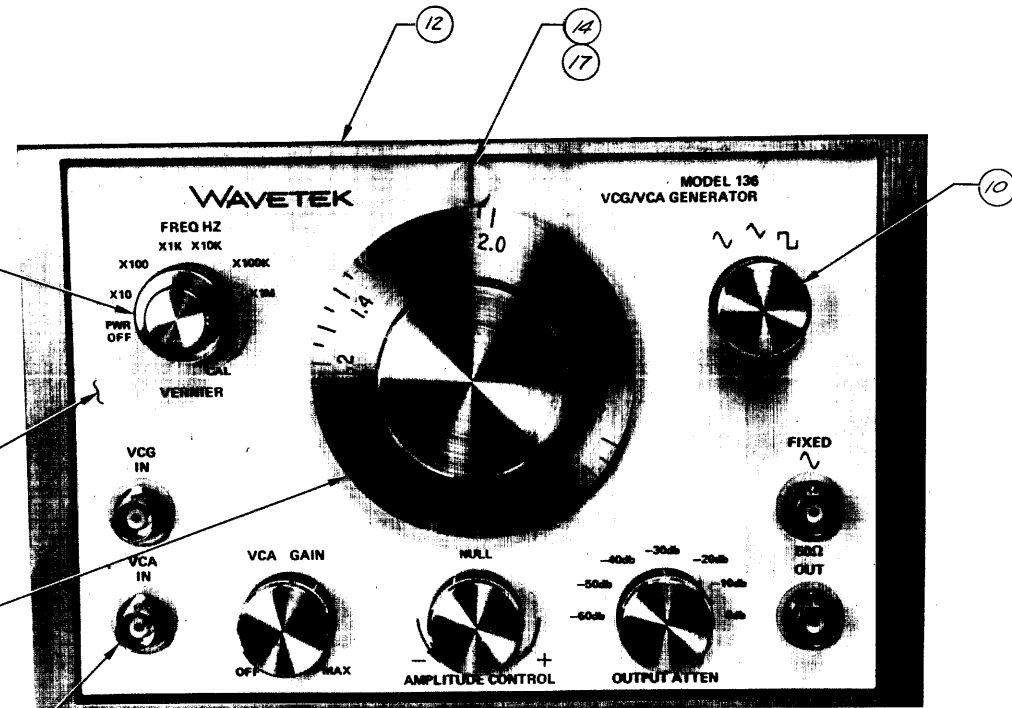
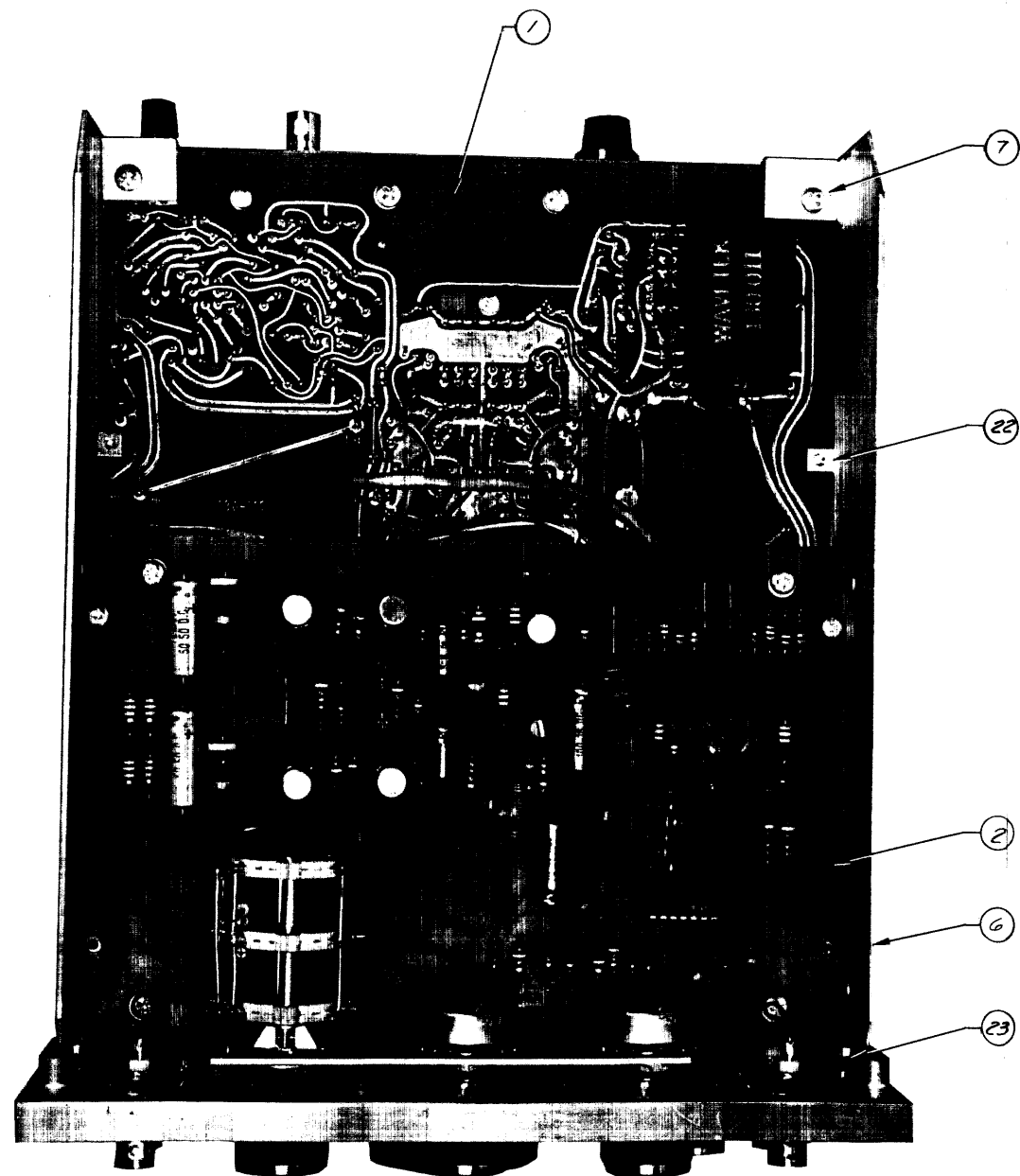

PARTS LIST

| ITEM | REF DES | DESCRIPTION | MFG | MFG. NO. | QTY |
|------|---------|----------------------|----------|-------------|-----|
| 1 | | MAIN BOARD | WAVETEK | D136-010 | 1 |
| 2 | | X-Y MULTIFREQ BD | | D-013 | 1 |
| 3 | | CASTING, REAR | | B/34-300 | 1 |
| * 4 | | COVER | | C130-301D | 1 |
| * 5 | | REAR PANEL | B | -303 | 1 |
| 6 | | SIDE PLATE | C | -304G | 2 |
| 7 | | MOUNTING BLOCK | A | -305 | 2 |
| 8 | | DIAL KNOB | B | -308B | 1 |
| 9 | | CO-AXIAL KNOB | B | -309A | 1 |
| 10 | | STANDARD KNOB | B | -314A | 4 |
| 11 | | SMALL KNOB | B | -310A | 1 |
| 12 | | CASTING MODIFICATION | B | -313-1 | 1 |
| 13 | | FRONT PANEL | | B/34-302-3 | 1 |
| 14 | | INDICATOR LENS | | A41-317 | 1 |
| 15 | | DIAL | | B/30-333A | 1 |
| 16 | | POT, MODIFIED 5K | | A/31-RIA | 1 |
| * 17 | | RETAINER | TRVAC | 5305-31 | 1 |
| 18 | J243,6 | BNC CONNECTOR | KING | KL7946 | 4 |
| * 19 | | POWER CORD | BELDEN | 17258-S | 1 |
| * 20 | | HANDLE | QUALITY | 1162 | 1 |
| * 21 | | CAPTIVE SCREW | DEUTSCH | T900-10-B-2 | 2 |
| 22 | | CHASSIS FASTENER | USCO | 1591B | 8 |
| 23 | | CLIP NUT | SNUR-LOC | SL210-06-2 | 4 |
| 24 | | BUSHING | THOMPSON | 4L8FF | 5 |
| 25 | | SHOULDER WASHER | SMITH | 2668 | 5 |
| 26 | | SOLDER LUG | | | 6 |
| * 27 | | FOOT | BUDNIS | F4B | 4 |
| 28 | | | | | |

NOTE: ASTERISK (*) INDICATES ITEM NOT SHOWN

| | | | | | |
|---|---------------------------------|----------|-----|------|------|
| tolerance unless otherwise specified | rev | ecr | by | date | app. |
| .XXX ± .010 .XX ± .030 | | | | | |
| scale N/A | WAVETEK san diego, calif | | | | |
| material | by GRAY date 12/18/69 app. JLB | | | | |
| | title | | | | |
| | CHASSIS ASSY | | | | |
| finish | model no. | dwg no. | rev | | |
| N/A | 136 | D136-000 | A | | |
| this document contains proprietary information and design rights belonging to WAVETEK and may not be used or reproduced for any reason except calibration, operation and maintenance without written authorization. | | | | | |

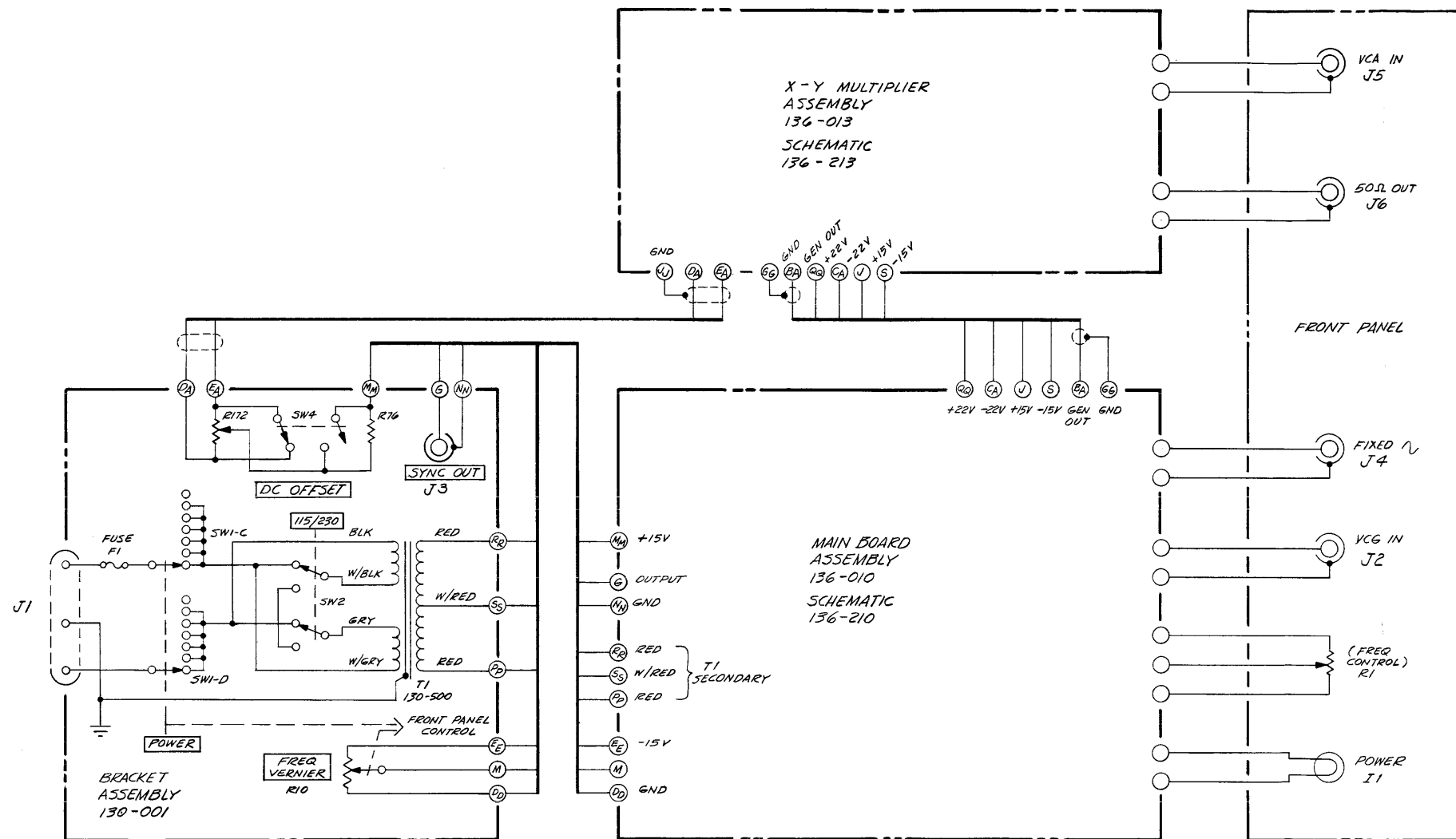

NOTES: UNLESS OTHERWISE SPECIFIED
 1. LETTER DESIGNATIONS ARE INTERCONNECTION POINTS.
 REFER TO ASSEMBLY DWGS FOR CONNECTION POINTS
 NOT LISTED.

| | | | | | |
|--------------------------------------|---|------|-------------------|-----------|------|
| tolerance unless otherwise specified | rev | ecr | by | date | app. |
| .XXX ± .010 .XX ± .030 | | | | | |
| scale NA | WAVETEK | | san diego, calif. | | |
| material | by | MAST | date | 15 DEC 69 | app. |
| NA | title | | | | |
| | SCHEMATIC, CHASSIS | | | | |
| finish | model no. | 136 | dwg no. | D136-200 | rev. |
| NA | This document contains proprietary information and design rights belonging to WAVETEK and may not be used or reproduced for any reason except calibration, operation and maintenance without written authorization. | | | | |

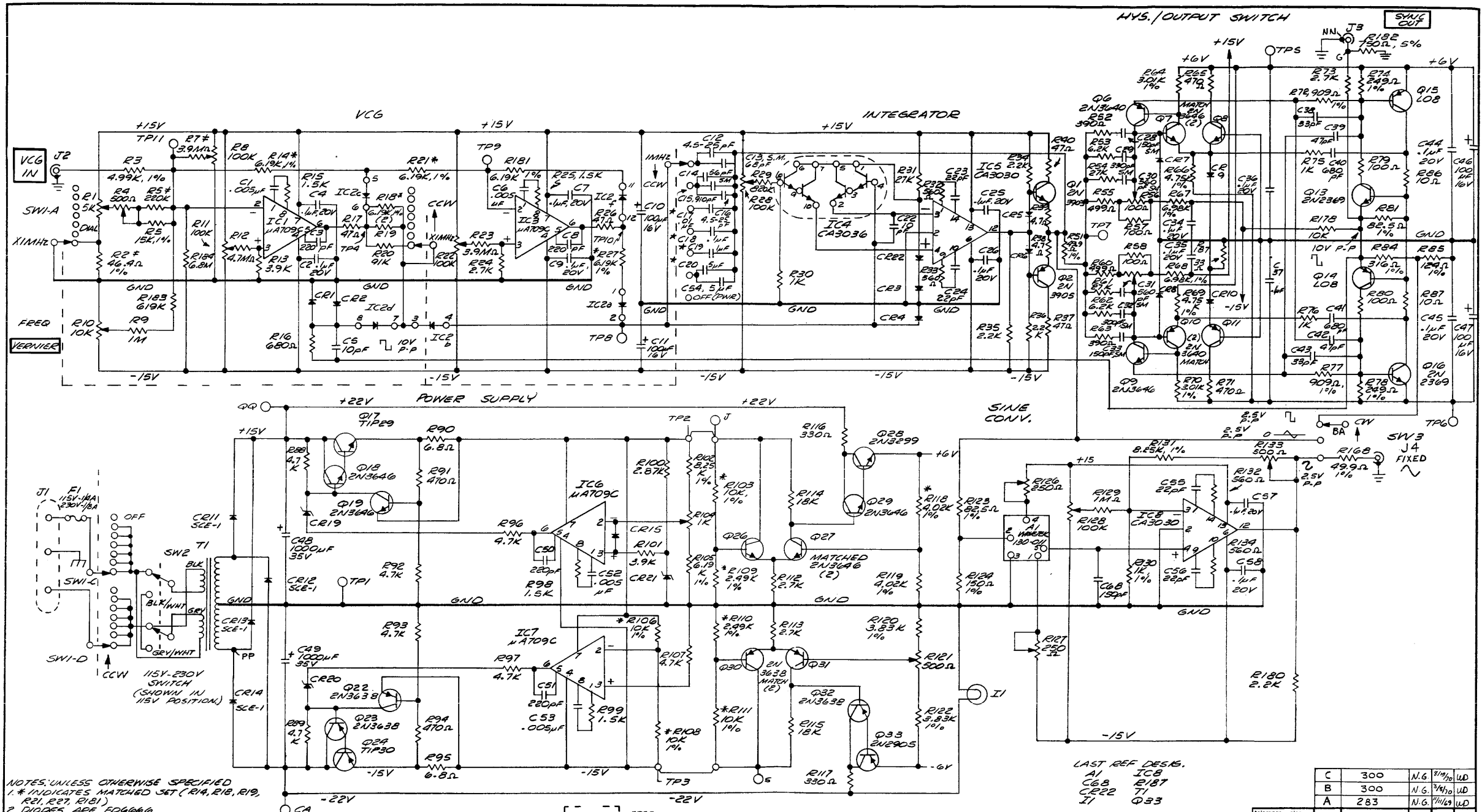

NOTES: UNLESS OTHERWISE SPECIFIED
 1. * INDICATES MATCHED SET (R14, R18, R19, R21, R27, R21)
 2. DIODES ARE FD6666
 3. RESISTORS ARE CARBON 1/2W
 4. * C17, C18, C19, C20, C54 ARE A MATCHED SET
 5. IC2, IC3, IC4, IC5 ARE SELECTED
 6. IC2, IC4, IC5 ARE SELECTED
 7. # INDICATES SELECTED VALUE; NOMINAL VALUE AS SHOWN.
 8. ZENER DIODES SELECTED PER WAVETEK SPEC. 130-506 (CR 19, 20, 21)

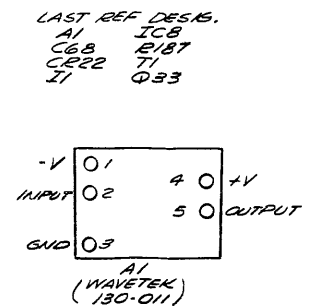
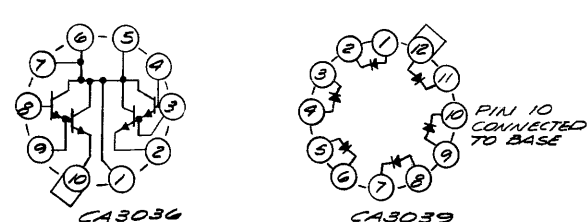
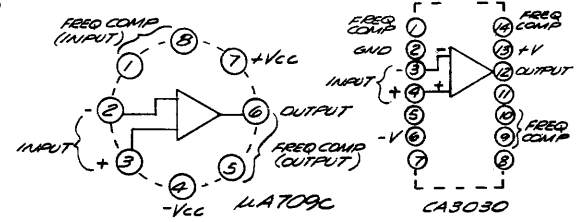

LAST REF DESIG.
 A1 ICB
 C68 E187
 CR22 T1
 I1 Q33

| | | | | | |
|---|------------------------------|------------|-----|------|------|
| tolerance unless otherwise specified | rev | ecn | by | date | app. |
| .xx ± 010 | | | | | |
| .xx ± 030 | | | | | |
| scale - | WAVETEK san diego, calif | | | | |
| material - | by G8AY date 4-5-71 app. J10 | | | | |
| finish - | title SCHEMATIC MAIN BOARD | | | | |
| | model no. | dwg no. | rev | | |
| | 136 | D136-210 C | C | | |
| This document contains proprietary information and design rights belonging to WAVETEK and may not be used or reproduced for any reason except calibration, operation and maintenance without written authorization. | | | | | |

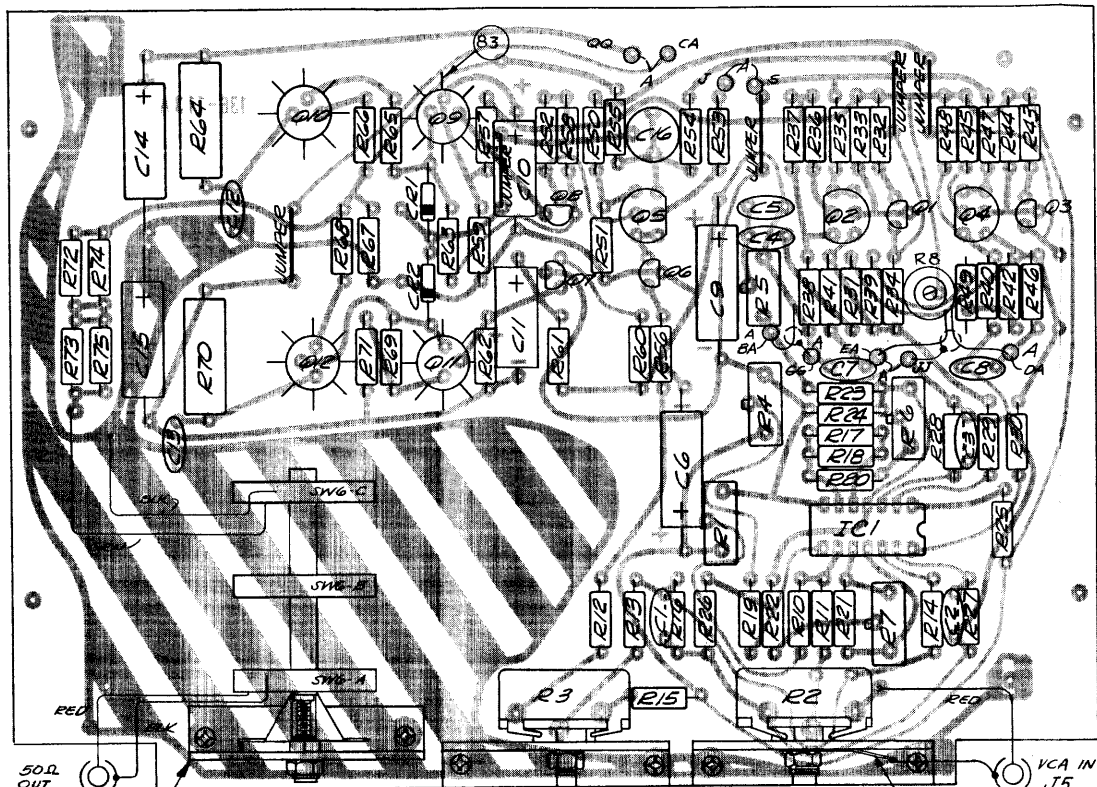

| ITEM | REF DES | DESCRIPTION | MFG | MFG NO. | QTY |
|------------|---------|-------------------------|----------|-------------------|-----|
| PARTS LIST | | | | | |
| CAPACITORS | | | | | |
| 1 | C4 | CERAMIC 100V 5pF | CRL | DD 050 | 1 |
| 2 | C5 | 47pF | | DD 470 | 1 |
| 3 | C3 | 50V .04F | | CK 103 | 6 |
| 4 | C2,3,7 | | | | |
| 5 | C1 | .001uF | | DD 102 | 1 |
| 6 | C0,11 | ELECT 16V .5uF | SPRAGUE | 5000SD0800LBA7 | 2 |
| 7 | C14,15 | 50V 50uF | | 5000SD060500D07 | 2 |
| 8 | C6,9 | ELECT 16V 100uF | | 500010750000C07 | 2 |
| 9 | C16 | CAP VARIABLE 35-15pF | STETTNER | TS-TRND-Q2-3.3 13 | 1 |
| 10 | | | | | |
| 11 | | | | | |
| 12 | | | | | |
| 13 | | | | | |
| 14 | | DIODES | | | |
| 15 | CR1-CR2 | FD6666 | | FD6666 | 2 |
| 16 | | | | | |
| 17 | | | | | |
| 18 | IC1 | INTEGRATED CIRCUIT | MOTOROLA | MC 1595L | 1 |
| RESISTORS | | | | | |
| 19 | | | | | |
| 20 | R1,78 | METAL FILM 1/4W 1% 190Ω | CORNING | ENGOD | 4 |
| 21 | R81 | 249Ω | | | 1 |
| 22 | RR0,87 | 825Ω | | | 2 |
| 23 | | | | | |

| ITEM | REF DES | DESCRIPTION | MFG | MFG NO. | QTY |
|------------|-----------------------|---------------------|---------|------------|-----|
| PARTS LIST | | | | | |
| RESISTORS | | | | | |
| 24 | | | | | |
| 25 | R53,65 | CARBON 1/2W, 5% 39Ω | STAMPON | RC206F390J | 3 |
| 26 | R64,70 | 2W 47Ω | | RC426F470J | 2 |
| 27 | R36,45 | 1/2W 100Ω | | RC206F100J | 2 |
| 28 | R32,43 | 10%, 220Ω | | 221K | 2 |
| 29 | R26,23 | 680Ω | | 681K | 3 |
| 30 | R52 | 820Ω | | 821K | 1 |
| 31 | R11,12,14,15,16,17,67 | 1K | | 102K | 5 |
| 32 | R53 | 1.5K | | 152K | 1 |
| 33 | R21,33,44 | 2.2K | | 222K | 3 |
| 34 | R57 | 3K | | 302K | 1 |
| 35 | R56 | 3.3K | | 332K | 1 |
| 36 | R19 | 82K | | 883K | 1 |
| 37 | R63,69 | 4.7K | | 472K | 2 |
| 38 | R60 | 7.5K | | 752K | 1 |
| 39 | R20 | 8.2K | | 822K | 1 |
| 40 | R16 | 10K | | 103K | 1 |
| 41 | R35,47,59 | 12K | | 123K | 3 |
| 42 | R61 | 33K | | 333K | 1 |

| ITEM | REF DES | DESCRIPTION | MFG | MFG NO. | QTY |
|-------------|--------------|-------------------------|-----------|------------|-----|
| PARTS LIST | | | | | |
| RESISTORS | | | | | |
| 43 | | | | | |
| 44 | R13 | CARBON 1/2W 10% 39K | STAMPON | RC206F393K | 1 |
| 45 | R22 | 47K | | 473K | 1 |
| 46 | R24 | 100K | | 104K | 1 |
| 47 | R10 | 1M | | 105K | 1 |
| 48 | R66,68 | 5% 4.7Ω | | 4E7J | 2 |
| 49 | R29,30 | 47Ω | | 470J | 2 |
| 50 | R85 | METAL FILM 1/4W 1% 619Ω | CORNING | ENGOD | 1 |
| 51 | R79 | 71.5Ω | | | 1 |
| 52 | R50,54 | 1K | | | 2 |
| 53 | R25 | 1.62K | | | 1 |
| 54 | R34,46 | 2K | | | 2 |
| 55 | R37,48 | 2.37K | | | 2 |
| 56 | R17,18 | 2.49K | | | 2 |
| 57 | R38,49 | 4.64K | | | 2 |
| 58 | R41,42,51,55 | 4.99K | | | 4 |
| 59 | R27,28 | 6.19K | | | 2 |
| 60 | R39,40 | 8.25K | | | 2 |
| 61 | R72,73,74,75 | 49.9Ω | | | 4 |
| 62 | R21 | 1.78K | | | 1 |
| 63 | R77 | 27.4Ω | | | 1 |
| 64 | R86 | 59.9Ω | | | 1 |
| 65 | R84,88 | 59Ω | | | 2 |
| 66 | | POTENTIOMETERS | | | |
| 67 | R5 | 1K | CRL | BA1603-803 | 1 |
| 68 | R2,3 | 10K | CTS | 136-R1 | 2 |
| 69 | | | | | |
| 70 | R14,7,6 | 100K | CRL | BA1603-819 | 4 |
| 71 | R8 | 2.5K | A/B | FR252M | 1 |
| 72 | | | | | |
| TRANSISTORS | | | | | |
| 73 | | | | | |
| 74 | Q9,12 | 2N2905 | FAIRCHILD | 2N2905 | 2 |
| 75 | Q10,11 | 3299 | | 3299 | 2 |
| 76 | Q7,8 | 3640 | | 3640 | 2 |
| 77 | Q3,6,1 | 3646 | | 3646 | 3 |
| 78 | Q2,4,5 | TD101 | SPRAGUE | TD101 | 3 |
| 79 | | | | | |
| 80 | | SOLDER LUG | | | 1 |
| 81 | SWG | SWITCH ASSY | CTS | 136-SW1A | 1 |
| 82 | | CIRCUIT BOARD | WAVETEK | 136-113A | 1 |
| 83 | | HEAT RADIATOR | WAVETEK | NF 207 | 4 |
| 84 | | TRANSIPAD | ROSS | 10160 | 4 |
| 85 | OA | AMP PINS | AMP | G1182-2 | 9 |
| 86 | | CONTROL BRACKET | WAVETEK | 136-304 | 3 |
| 87 | | SHIELD | WAVETEK | 136-302 | 1 |
| 88 | | SHIELD STANDOFF | USECO | 1530B 1/4 | 4 |

NOTES: UNLESS OTHERWISE SPECIFIED
 1. SWITCH WAFERS A THRU C ARE SHOWN AS VIEWED FROM THE FRONT OF THE INSTRUMENT.
 2. LETTER DESIGNATIONS ARE INTERCONNECTION POINTS.
 3. REFER TO SCHEMATIC DWG 136-213 FOR TERMINATION POINTS.
 4. AMP PINS, INDICATED BY "A" ARE INSTALLED FROM CIRCUIT SIDE.
 5. FAIRCHILD M2905C MAY BE USED AS AN INTERCHANGEABLE ALTERNATE FOR MOTOROLA MC 1595L

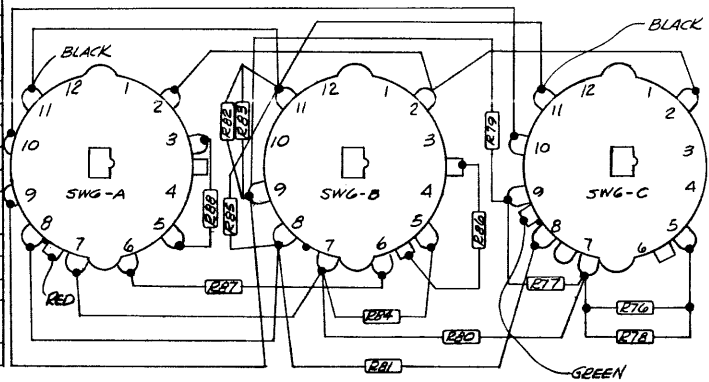

| | | | | |
|---|---------|-----|---------|------|
| D | 361 | 24K | 1/11/73 | T.O. |
| C | RCN 319 | NG | 1/11/73 | T.O. |
| B | COP 44 | NS | 1/12/73 | T.O. |
| A | RCN 300 | NS | 2/22/73 | T.O. |
| rev | ecm | by | date | app. |
| WAVETEK san diego, calif | | | | |
| .XXX ± 010 .XX ± 030 scale N/A material N/A finish N/A | | | | |
| model no. 136 dwg no. D136-013 rev D | | | | |
| This document contains proprietary information and design rights belonging to WAVETEK and may not be used or reproduced for any reason except calibration, operation and maintenance without written authorization. | | | | |

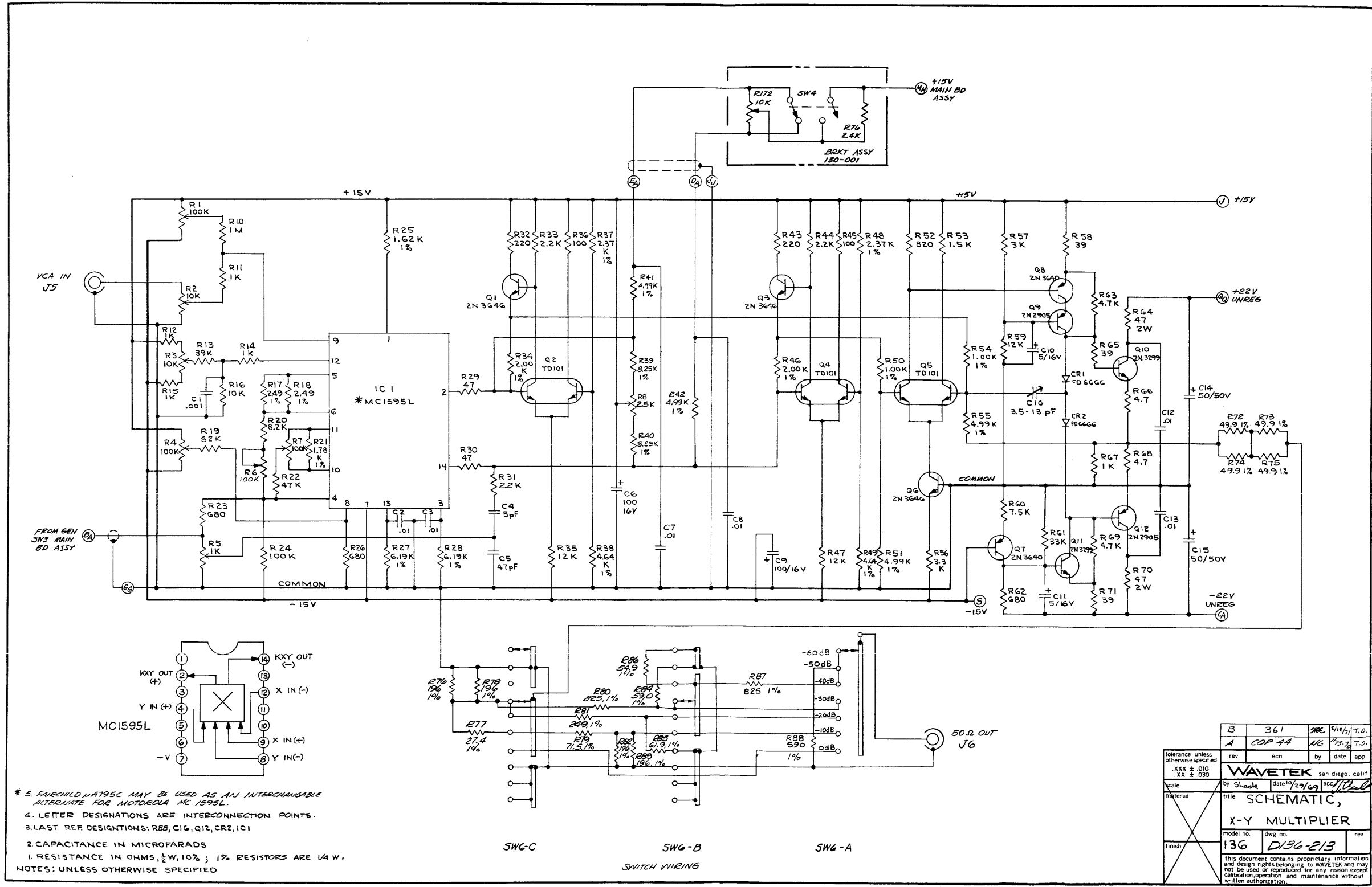

* 5. FAIRCHILD μ A795C MAY BE USED AS AN INTERCHANGEABLE ALTERNATE FOR MOTOROLA MC 1595L.

4. LETTER DESIGNATIONS ARE INTERCONNECTION POINTS.

3. LAST REF DESIGNATIONS: R88, C10, Q12, CR2, IC1

2. CAPACITANCE IN MICROFARADS

1. RESISTANCE IN OHMS, $\frac{1}{2}$ W, 10% ; 1% RESISTORS ARE $\frac{1}{4}$ W.

NOTES: UNLESS OTHERWISE SPECIFIED

| | | | | |
|--------------------------------------|--|----------|---------|-----------|
| B | 361 | AKC | 9/19/69 | T.O. |
| A | COP 44 | MG | 7/3/69 | T.O. |
| tolerance unless otherwise specified | rev | ecm | by | date app. |
| xxx ± 010 | | | | |
| xx ± 030 | | | | |
| scale | by Shack date 10/29/69 app. J. Bull | | | |
| material | title SCHEMATIC, | | | |
| | X-Y MULTIPLIER | | | |
| | model no. | dwg no. | rev | |
| | 136 | D136-213 | | |
| finish | This document contains proprietary information and design rights belonging to WAVETEK and may not be used or reproduced for any reason except calibration operation and maintenance without written authorization. | | | |

9045 Balboa Ave., San Diego, California Tel. 279-2200, P.O. Box 651, San Diego, California 92112